

REB-21R Series

Operational Manual

Version 1.1
2002/11/15

This document contains information highly confidential to RoyalTek Company LTD (RoyalTek). It is provided for the sole purpose of the business discussions between supplier and RoyalTek and is covered under the terms of the applicable Non-Disclosure Agreements. Disclosure of this information to other parties is prohibited without the written consent of RoyalTek.

Prepared by
RoyalTek Company LTD.

1071, Chung Cheng Rd., Suite 9F-1
Tao Yuan City, Taiwan, R.O.C.
TEL: 886-3-3569666
FAX: 886-3-3580050
E-Mail: sales@royaltek.com

<http://www.royaltek.com>

RoyalTek REB-21R series Operational Manual

INTRODUCTION.....	1
PRODUCT FEATURES	1
PRODUCT APPLICATIONS	1
TECHNIQUE DESCRIPTION	1
<i>Pictures of REB-21R series</i>	1
<i>REB-21R Series Block diagram</i>	2
TECHNIQUE SPECIFICATIONS	2
SERIAL NUMBER DEFINITION	3
MECHANICAL LAYOUT.....	4
HARDWARE INTERFACE.....	5
ACTIVE ANTENNA.....	9
ABSOLUTE MAXIMUM RATINGS	10
ORDERING INFORMATION.....	10
SOFTWARE INTERFACE	10
<i>NMEA V2.2 Protocol</i>	10
<i>GGA-Global Positioning System Fixed Data</i>	10
<i>GLL-Geographic Position – Latitude/Longitude</i>	11
<i>GSA-GNSS DOP and Active Satellites</i>	11
<i>GSV-GNSS Satellites in View</i>	12
<i>RMC-Recommended Minimum Specific GNSS Data</i>	12
<i>VTG-Course Over Ground and Ground Speed</i>	13
CONTACT INFORMATION SECTION	14

Introduction

REB-21R is the new generation of RoyalTek GPS Receiver. It consists of SiRF Star II technology and RoyalTek proprietary navigation algorithm that providing you more stable navigation data. REB-21R contains series of different combination of 20 pins header, RF connector, protocol and so on. Please refer to the section, **serial number definition**, for more information.

Product Features

- ✧ OEM product development is fully supported through applications engineering and WEB technique forum.
- ✧ 12 parallel channels
- ✧ 0.1 second re-acquisition time.
- ✧ Enhanced algorithm for navigation stability.
- ✧ NMEA-0183 compliant protocol/custom protocol.
- ✧ Excellent sensitive for urban canyon and foliage environments.
- ✧ Single satellite positioning.
- ✧ Dual multi path rejection.
- ✧ **Fully compatible to Royaltek existing product (REB-12R).**
- ✧ WAAS/EGNOS supported
- ✧ RTC Crash Protection

Product applications

- ✧ Automotive applications
- ✧ Personal positioning and navigation
- ✧ Marine navigation
- ✧ Timing application

Technique description

Pictures of REB-21R series

REB-21R

- Illustrated pictures of REB-21R with short-down 20 pins header and right angle-up SMA connector

(Front-side View)



(Back-side View)



REB-21R Series Block diagram

The block diagram is described as follows.

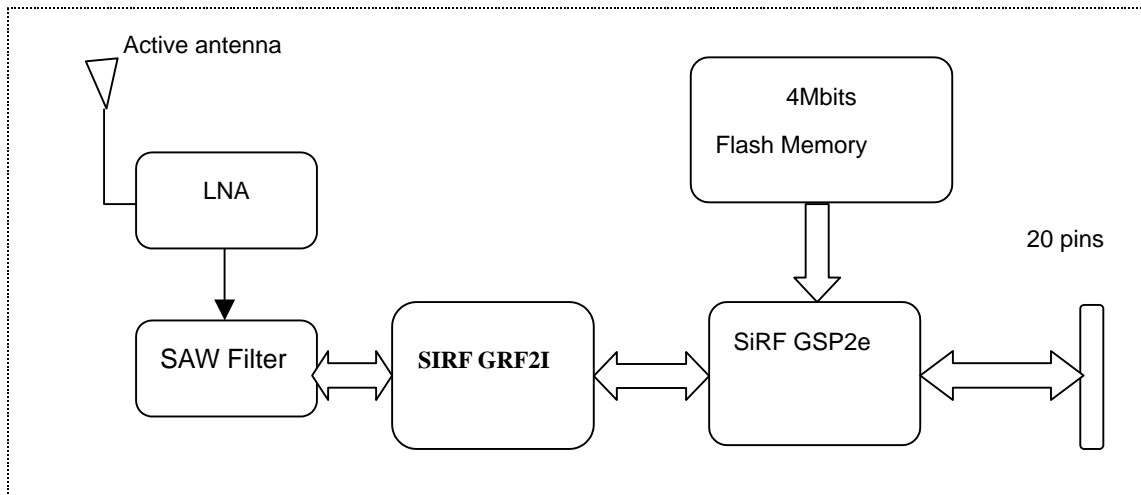

Technique specifications

The specification list of REB-21R series

Operational Characteristics.

- 12 Channels
- L1, 1575.42MHz.
- C / A code, 1.023MHz chip rate.
- Snap start:2second, average
- Hot start ▪ 8second, average
- Warm start ▪ 38second, average
- Cold start ▪ 48second, average
- Reacquisition:0.1 second, average
- Navigation update rate ▪ Once per second.
- Datum: WGS-84.

Accuracy.

- Position accuracy ▪ 10m 90% without SA
- Velocity accuracy:0.1 meters/second without SA

DGPS Accuracy.

- Position:1 to 5 m, typical
- Velocity: 0.05 meters/second, typical

DGPS Source

- 1) WAAS/EGNOS
- 2) RTCM-104 DGPS via RXB serial input.

Dynamics.

- Altitude ▪ 18000 meters (60000 feet) max.
- Velocity ▪ 515 meters / second Max.
- Acceleration ▪ 4 g , Max.

Power Requirements.

Regulated power for the REB-21R series is required. The input voltage shall be 5.0V ± 10%(5 volt version) or 3.3V ± 10%. (3.3volt version). Maximum current is less than 180mA.

Weight. 19.3g

Environment.

Temperature.

- Operating temperature -40 ~ +85 Degree (Celsius).
- Storage temperature: -40 ~ +85 Degree (Celsius).

Humidity. ≤95% non-condensing

Serial number definition

LXHA/LXHS	Power	Trickle Power	RF Connector	20pin I/O	Backup battery	Signal level of serial data I/O	Ant. Power & Others	Memory Type	Software
1	2	3	4	5	6	7	8	9	10
1: LXHA	3: 3.3V 5: 5V	0: Disable	1: MCX straight-angle-up 3: MCX right-angle-up 5: SMA straight-angle-up 7: SMA right-angle-up 9: SMA female with 15cm cable A: SMA female with 10cm cable B: MCX right-angle-6mm-up	1: 6mm-down 2: 6mm-up 9: 8mm-down A: 8mm-up	0: None 1: Super CAP 2: Li-Ion battery.	1: TTL	3: Standard 3.3V 5: Standard 5V	1: Flash memory	1: RMC, 9600 2: GGA ,GLL, GSA, GSV, RMC, V0TG, 9600 3: GGA, GSA, GSV, RMC, 4800 [GSV : every 5 seconds] [GGA,GSA and RMC : every second] 4.GGA, GSA, RMC,4800 5. GGA, VTG, 4800 6. SIRF Binary ,19200 8.GGA,VTG,GLL, only, 9600 9. GGA, GSA, RMC,9600 A. RMC only , 4800 B. RMC only , 19200 E: VTG,GLL, 4800 update rate:2 sec

Mechanical Lavout.

REB-21R with 20 pins connector and straight-up MCX RF connector

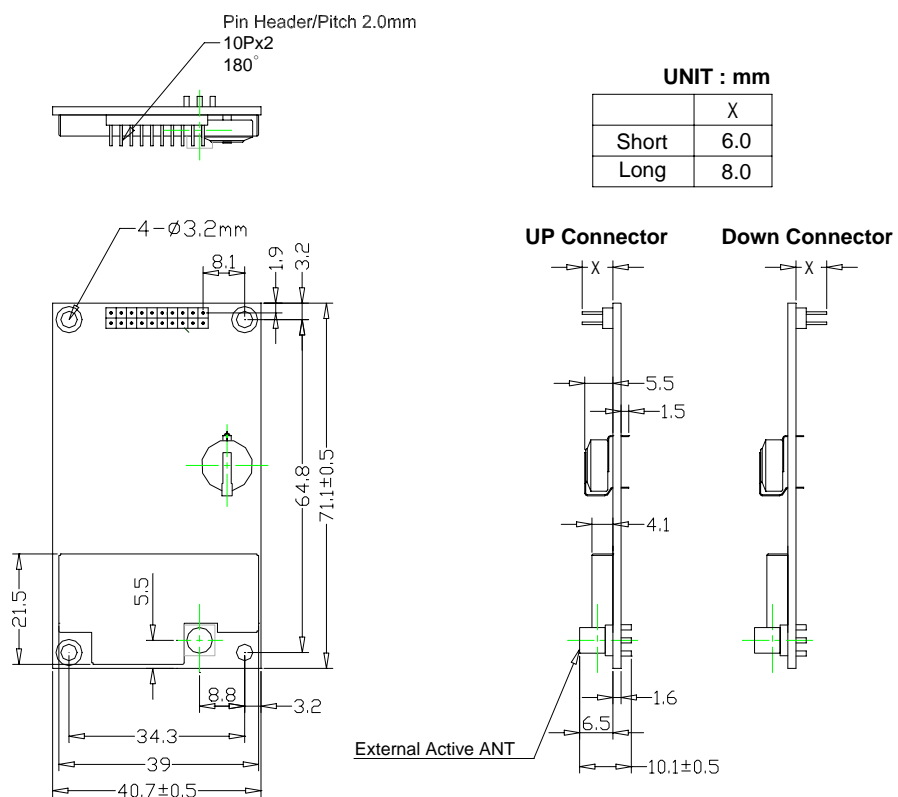

Hardware interface

For 5V TTL & RS-232 Output

Pin NO	Signal Name	I/O	Description	Characteristics
1	VANT	I	Antenna DC Voltage	Depending on the user requirement..
2	VCC_5	I	+5V DC Power Input	DC +5V \pm 10%.
3	VBAT	I	User Supply +2.6~3.6V DC Power Input*	DC +2.6~3.6V. Current \leq 10uA w/o battery
4	RESERVED		Reserved	
5	RESERVED	I	Reserved	Not connection
6	RESERVED	-	Reserved	
7	RESERVED /Boot	I	Boot selection. Please do not connect it to high. Please leave it open or ground.	$V_{ih} \geq 0.7*VDD$ $V_{il} \leq 0.3V*VDD$
8	RESERVED	-	Reserved	
9	RESERVED	-	Reserved	
10	GND	G	Ground	
11	TXA	O	NMEA Output 9600bps, 8 data bits, no parity, 1 stop bit	TTL : 0V to 5V \pm 10%, or RS232 : $V_{oh} \geq 6$, $V_{o1} \leq -6V$,
12	RAX	I	Serial Data Input A	TTL : 0V to 5V \pm 10%, or RS232 : $3V \leq V_{ih} \leq 15V$, $-15V \leq V_{il} \leq -3V$
13	GND	G	Ground	
14	TXB	O	Serial Data Output B	TTL : 0V to 5V \pm 10%, or RS232 : $V_{oh} \geq 6$, $V_{o1} \leq -6V$,
15	RXB	I	RTCM 104 differential GPS input.	TTL : 0V to 5V \pm 10%, or RS232 : $3V \leq V_{ih} \leq 15V$, $-15V \leq V_{il} \leq -3V$
16	GND	G	Ground	
17	NC/BOOTSEL	-	Boot selection. Please do not connect it to high. Please leave it open or ground.	$V_{ih} > 2.3V$ $V_{il} < 0.8V$
18	GND	G	Ground	
19	TIMEMARK	O	1PPS Time Mark Output.	$V_{oh} \geq 2.4V$, $V_{o1} \leq 0.2V$,
20	NC	-	NC	

VCC_5 DC Power Input

This is the main power supply for the GPS

Engine board. Use a regulated 5V supply (\pm 5%) capable of supplying 180mA.

VANT

DC voltage for an active antenna. This voltage is not required for operation with a passive antenna.

GND

GND provides the ground for the Engine board. Connect all grounds.

Serial Data: RXA, RXB, TXA, and TXB

The GPS Engine board supports two full duplicated serial channels. All four connections are at TTL levels, and all support variable baud rates. A TTL to RS232 conversion is necessary to directly communicate with a PC serial port.

RXA

This is the main receiving channel and is used to receive software commands to the Engine board from user written software.

RXB

This is the auxiliary receive channel and is used to input differential corrections to the Engine board to DGPS navigation.

TXA

This is the main transmit channel and is used to output navigation and measurement data to user written software.

TXB

Reserved.

TIMEMARK

This pin provides one pulse per second output from the engine board which is synchronized to within one microsecond of GPS time. The output is a TTL negative level signal with negative logic.

VBAT

This is the battery backup supply that powers the SRAM and RTC when main

power is removed. Without an external backup battery or on board battery, engine board will execute a cold start after every turn on. To achieve the faster start-up offered by a hot or warm start, either a backup battery must be connected or battery installed on board.

For 3.3Volt TT L&RS-232 Output

PinNO	Signal Name	I/O	Description	Characteristics
1	VANT	I	Antenna DC Voltage	Depending on the user requirement..
2	RESERVED	I	Reserved	
3	VBAT	I	User Supply +2.6~3.6V DC Power Input w/o battery	DC ++2.6~3.6V. Current $\leq 10\mu\text{A}$ (w/o battery)
4	VCC_3		DC+3.3V $\pm 10\%$	DC +3.3V $\pm 10\%$
5	RESERVED	I	Reserved	Not connection
6	NC/GPIO15	I/O	HA:NC HS:GPIO15	$V_{ih} \geq 0.7V * V_{DD}$, $V_{i1} \leq 0.3V * V_{DD}$ $V_{oh} \geq 2.4V$ $V_{o1} \leq 0.2V$
7	NC/GPIO3	I/O	HA:Boot HS:GPIO3	$V_{ih} \geq 0.7V * V_{DD}$, $V_{i1} \leq 0.3V * V_{DD}$ $V_{oh} \geq 2.4V$ $V_{o1} \leq 0.2V$
8	NC/GPIO7	I/O	HA:NC HS:GPIO7	$V_{ih} \geq 0.7V * V_{DD}$, $V_{i1} \leq 0.3V * V_{DD}$ $V_{oh} \geq 2.4V$ $V_{o1} \leq 0.2V$
9	NC/GPIO5	I/O	HA:NC HS:GPIO5	$V_{ih} \geq 0.7V * V_{DD}$, $V_{i1} \leq 0.3V * V_{DD}$ $V_{oh} \geq 2.4V$ $V_{o1} \leq 0.2V$
10	GND	G	Ground	
11	TXA	O	NMEA Output 9600bps, 8 data bits, no parity, 1 stop bit	TTL: $V_{oh} \geq 2.4V$ $V_{o1} \leq 0.2V$ RS-232: $V_{oh} \geq 6V$, $V_{o1} \leq -6V$,
12	RXA	I	Serial Data Input A	TTL: $V_{ih} \geq 0.7V * V_{DD}$, $V_{i1} \leq 0.3V * V_{DD}$ RS-232: $3V \leq V_{ih} \leq 15V$, $-15V \leq V_{il} \leq -3V$
13	GND/GPIO10	G	I/O;Ground	
14	TXB	O	Serial Data Output B	TTL: $V_{oh} \geq 2.4V$ $V_{o1} \leq 0.2V$ RS-232: $V_{oh} \geq 6$, $V_{o1} \leq -6V$,
15	RXB	I	RTCM 104 differential GPS input.	TTL: $V_{ih} \geq 0.7V * V_{DD}$, $V_{i1} \leq 0.3V * V_{DD}$ RS-232: $3V \leq V_{ih} \leq 15V$, $-15V \leq V_{il} \leq -3V$
16	GPIO6	I/O-	GPIO6	
17	GPIO5	I/O-	SH-1 PA15(Note1,3)	$V_{ih} \geq 0.7V * V_{DD}$, $V_{i1} \leq 0.3V * V_{DD}$ $V_{oh} \geq 2.4V$ $V_{o1} \leq 0.2V$
18	GND	G	Ground	
19	TIMEMARK	O	1PPS Time Mark Output.	$V_{oh} \geq 2.4V$ $V_{o1} \leq 0.2V$
20	NC	-	NC	

Notes: HA version: non GPIO, HS version: with GPIO

Note 1). Software dependent functions.

2) Pulled high on board

- 3) Pulled low on board. This pin can be as firmware upload selection pin. To upload new firmware, tie this pin high and cycle the power.

VANT

DC voltage for an active antenna. This voltage is not required for operation with a passive antenna.

VCC_3 DC Power Input

RoyalTek also provides the 3.3 V version GPS receiver. This is the main power supply for the Engine board. Use a regulated 3.3V supply ($\pm 10\%$).

GND

GND provides the ground for the Engine board. Connect all grounds.

Serial Data: RXA, RXB, TXA, and TXB

The GPS Engine board supports two full duplicated serial channels. All four connections are at TTL levels, and all support variable baud rates. A TTL to RS232 conversion is necessary to directly communicate with a PC serial port.

RXA

This is the main receiving channel and is used to receive software commands to the Engine board from user written software.

RXB

This is the auxiliary receive channel and is used to input differential corrections to the Engine board to DGPS navigation.

TXA

This is the main transmit channel and is used to output navigation and measurement data to user written software.

TXB

Reserved.

.

TIMEMARK

This pin provides one pulse per second output from the engine board which is synchronized to within one microsecond of GPS time. The output is a TTL negative level signal with negative logic.

VBAT

This is the battery backup supply that powers the SRAM and RTC when main power is removed. Without an external backup battery or on board battery, engine board will execute a cold start after every turn on. To achieve the faster start-up offered by a hot or warm start, either a backup battery must be connected or battery installed on board.

Active antenna.

GSP Antenna

Characteristics	Specification
Center frequency	1575.42 ± 1.023MHz
Bandwidth	2MHz Min.
Gain at Zenith	2.0 dBi Min.
Gain at 10° elevation	-4.0 dBi Min.
Polarization	R.H.C.P
Axial Ratio	4.0dB Max.

5V Filter/LNA:

Characteristics	Specification
Center frequency (fo)	1575.42 ± 1.023MHz
Gain	28dB Min.
Noise Figure	2.0dB Max.
Out band attenuation	2dB Min. fo ± 20MHz 12dB Min. fo ± 50MHz 22dB Min. fo ± 100MHz
Output V.S.W.R.	2.0 dB max.
Voltage	5.0 ± 0.5V
Current	12mA Max.

3.3V Filter/LNA:

Characteristics	Specification
Center frequency (fo)	1575.42 ± 1.023MHz
Gain	26dB Min.
Noise Figure	2.0dB Max.
Out band attenuation	2dB Min. fo ± 20MHz 12dB Min. fo ± 50MHz 22dB Min. fo ± 100MHz
Output V.S.W.R.	2.0 dB max.
Voltage	3.3 ± 0.3V
Current	12mA Max.

Absolute maximum ratings

Parameter	Symbol	Unit	Min. Value	Max. Value
Supply voltage	VCC_5	V	-0.3	6
RTC power	VBAT	V	-0.3	3.6

Ordering information

For the complete pricing and delivery information, please contact:

RoyalTek Company Ltd.

1071 Chung Cheng Rd., Suite 9F-1, Tao Yuan City, Taiwan, R.O.C.

Tel: 886-3-3569666

Fax: 886-3-3560900

Http://www.royaltek.com

e-mail: sales@royaltek.com

Software interface

following NMEA-0183 messages: GGA, GLL, GSA, GSV, RMC and VTG.

NMEA V2.2 Protocol

It is the RS-232 interface: 9600 bps, 8 bit data, 1 stop bit and no parity. It supports the

NMEA Output Messages

The Engine board outputs the following messages as shown in Table 1:

Table 1 NMEA-0183 Output Messages

NMEA Record	Description
GGA	Global positioning system fixed data
GLL	Geographic position – latitude / longitude
GSA	GNSS DOP and active satellites
GSV	GNSS satellites in view
RMC	Recommended minimum specific GNSS data
VTG	Course over ground and ground speed

GGA-Global Positioning System Fixed

example: \$GPGGA, 161229.487, 3723.2475, N, 12158.3416, W, 1, 07, 1.0, 9.0, M, , , , 0000*18

Data

Table 2 contains the values of the following

Table 2 GGA Data Format

Name	Example	Units	Description
Message ID	\$GPGGA		GGA protocol header
UTC Position	161229.487		hhmmss.sss
Latitude	3723.2475		ddmm.mmmm
N/S Indicator	N		N=north or S=south
Longitude	12158.3416		dddmm.mmmm
E/W Indicator	W		E=east or W=west
Position Fix Indicator	1		See Table 2-1
Satellites Used	07		Range 0 to 12
HDOP	1.0		Horizontal Dilution of Precision
MSL Altitude	9.0	meters	

Units	M	meters	
Geoid Separation		meters	
Units	M	meters	
Age of Diff. Corr.		second	Null fields when DGPS is not used
Diff. Ref. Station ID	0000		
Checksum	*18		
<CR> <LF>			End of message termination

Table 2-1 Position Fix Indicator

Value	Description
0	Fix not available or invalid
1	GPS SPS Mode, fix valid
2	Differential GPS, SPS Mode, fix valid
3	GPS PPS Mode, fix valid

GLL-Geographic Position – Latitude/Longitude

example:\$GPGLL, 3723.2475, N, 12158.3416, W, 161229.487, A*2C

Table 3 contains the values of the following

Table 3 GLL Data Format

Name	Example	Units	Description
Message ID	\$GPGLL		GLL protocol header
Latitude	3723.2475		ddmm.mmmm
N/S Indicator	N		N=north or S=south
Longitude	12158.3416		Dddmm.mmmm
E/W Indicator	W		E=east or W=west
UTC Position	161229.487		hhmmss.ss
Status	A		A=data valid or V=data not valid
Checksum	*2C		
<CR> <LF>			End of message termination

GSA-GNSS DOP and Active Satellites

example:\$GPGSA, A, 3, 07, 02, 26, 27, 09, 04, 15, , , , , 1.8,1.0,1.5*33

Table 4 contains the values of the following

Table 4 GSA Data Format

Name	Example	Units	Description
Message ID	\$GPGSA		GSA protocol header
Mode 1	A		See Table 4-2
Mode 2	3		See Table 4-1
Satellite Used	07		Sv on Channel 1
Satellite Used	02		Sv on Channel 2
....		
Satellite Used			Sv on Channel 12
PDOP	1.8		Position Dilution of Precision
HDOP	1.0		Horizontal Dilution of Precision
VDOP	1.5		Vertical Dilution of Precision
Checksum	*33		
<CR> <LF>			End of message termination

Table 4-1 Mode 1

Value	Description
1	Fix not available
2	2D
3	3D

Table 4-2 Mode 2

Value	Description
M	Manual-forced to operate in 2D or 3D mode
A	Automatic-allowed to automatically switch 2D/3D

GSV-GNSS Satellites in View

Table 5 contains the values of the following

example: \$GPGSV, 2, 1, 07, 07, 79,

048, 42, 02, 51, 062, 43, 26, 36,

256, 42, 27, 27, 138,

42*71\$GPGSV, 2, 2, 07, 09, 23,

313, 42, 04, 19, 159, 41, 15, 12,

041, 42*41

Table 5 GGA Data Format

Name	Example	Units	Description
Message ID	\$GPGSV		GSV protocol header
Number of Messages ¹	2		Range 1 to 3
Messages Number ¹	1		Range 1 to 3
Satellites in View	07		
Satellite ID	07		Channel 1(Range 1 to 32)
Elevation	79	degrees	Channel 1(Maximum 90)
Azimuth	048	degrees	Channel 1(True, Range 0 to 359)
SNR (C/No)	42	dBHz	Range 0 to 99, null when not tracking
....		
Satellite ID	27		Channel 4(Range 1 to 32)
Elevation	27	degrees	Channel 4(Maximum 90)
Azimuth	138	degrees	Channel 4(True, Range 0 to 359)
SNR (C/No)	42	dBHz	Range 0 to 99, null when not tracking
Checksum	*71		
<CR> <LF>			End of message termination

¹Depending on the number of satellites

GNSS Data

tracked multiple messages of GSV data may be required.

Table 6 contains the values of the following

example: \$GPRMC, 161229.487, A,

3723.2475, N, 12158.3416, W, 0.13,

309.62, 120598, ,*10

RMC-Recommended Minimum Specific

Table 6 RMC Data Format

Name	Example	Units	Description
Message ID	\$GPRMC		RMC protocol header
UTC Position	161229.487		hhmmss.sss
Status	A		A=data valid or V=data not valid
Latitude	3723.2475		ddmm.mmmm
N/S Indicator	N		N=north or S=south
Longitude	12158.3416		dddmm.mmmm
E/W Indicator	W		E=east or W=west
Speed Over Ground	0.13	knots	
Course Over	309.62	degrees	True

Ground			
Date	120598		ddmmyy
Magnetic Variation		degrees	E=east or W=west
Checksum	*10		
<CR> <LF>			End of message termination

example:\$GPVTG, 309.62, T, , M,

VTG-Course Over Ground and Ground

0.13, N, 0.2, K*6E

Speed

Table 7 contains the values of the following

Table 7 VTG Data Format

Name	Example	Units	Description
Message ID	\$GPVTG		VTG protocol header
Course	309.62	degrees	Measured heading
Reference	T		True
Course		degrees	Measured heading
Reference	M		Magnetic
Speed	0.13	knots	Measured horizontal speed
Units	N		Knots
Speed	0.2	km/hr	Measured horizontal speed
Units	K		Kilometer per hour
Checksum	*6E		
<CR> <LF>			End of message termination

Contact Information Section

■ **Contact : sales@royaltek.com**

■ **HEADQUARTER :**

Add : 1071 Chung Cheng Rd., Suite 9F-1

Tao Yuan City, Taiwan, R.O.C.

Tel : 886 – 3 - 3569666

Fax : 886 – 3 - 3580050

■ **Web Site : www.royaltek.com**

■ **Customer Service mail : sales@royaltek.com**