

Tuning the nRF24xx matching network

1. Preface

This white paper describes how to tune the matching network of the nRF24xx series radios for optimum performance. The nRF24L01 is used as an example, but the method shown is applicable for all Nordic 2.4GHz radios. A spectrum analyzer is needed to monitor the output signal and measure the performance while the components in the matching network are changed.

This white paper does not cover antenna tuning.

2. How it works

The antenna connection for the radio chip is differential. The impedance is different from 50 ohm. The components between the radio and the antenna are called the matching network and consist of the components shown in Figure 1.

The matching network has 4 main tasks:

1. Transform the balanced output of the radio to an unbalanced connection to the antenna (balun).
2. Transform the output impedance of the radio to a 50 ohm antenna.
3. Suppress harmonics to a level below the regulations level in TX mode.
4. Suppress the LO leakage in RX mode.

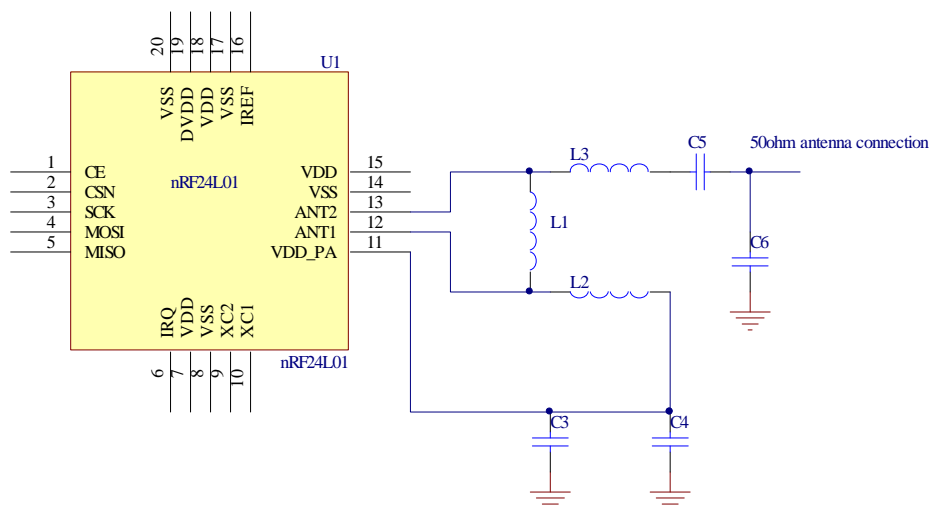

Figure 1- Matching network

The balun-function is done by the 180° degrees phase shift in L1. This causes the signals from the two ANT pins, 180° out of phase, to be added in the point between L1 and L3.



Tuning the nRF24xx matching network

The impedance transformation is done with L3 and C5.

Harmonic suppression is good because the matching network forms a low pass filter (series L and shunt C).

The LO leakage in RX mode is mainly a common mode signal. The LO leakage is shorted by C4 via L2.

Both ANT ports will see the same impedance due to the symmetric matching network. This ensures that the output PA in the TX will operate as designed.

VDD-PA is considered as AC ground. C3 and C4 forms a DC and AC decoupling. VDD-PA is the power supply to the output PA and there must be a DC path between VDD-PA and both ANT pins. The DC will flow through L2 and L1.

All components have parasitic effects. For instance, an inductor will have series R and shunt C and a capacitor will have a series L and shunt C in addition to the wanted C. The circuit board will also have some parasitic effects. These effects are included in the matching network. It is therefore difficult to calculate the component values. Complex simulation models, where all parasitic effects are included, are often necessary.

Components with different size and from different manufacturers will have different parasitic effects. A layout different from the Nordic recommended layout will also have different parasitic effects.

3. Tuning

To measure the performance of the matching network, two things are needed: Test firmware to run the radio, and a spectrum analyzer. The frequency range of the spectrum analyzer must be higher than the highest harmonic of interest. Normally it is sufficient to test up to the 3rd harmonic, but to it is preferable to test up to the 5th harmonic, e.g. 12,25GHz.

For the nRF24L01, it is easiest to connect the SPI-bus of the radio directly to the evaluation kit and use the test software to run the radio. It simplifies the channel selection and setting of a constant carrier. The MCU connected to the radio could be programmed with a test firmware which sets the channel and the TX mode to a constant carrier. Please refer to the datasheet of the device for details about this. It is also a good idea to have the test firmware sweep through the band to see if the performance changes over frequency.

The matching network will be optimal in both RX and TX mode if the TX output power is maximized at the same time as the harmonics and the RX LO are minimized. All these parameters must be measured every time a component value is changed. The RX sensitivity is directly proportional with the TX output power.

The spectrum analyzer must be connected to the 50ohm output of the matching network. If a PCB antenna is used, the trace to this must be cut in order to disconnect it. Use a suitable cable, small enough to solder to the board. The screen of the cable must be firmly connected



Tuning the nRF24xx matching network

to the ground plane of the board. The center connector is soldered to the 50 ohm point, between C5 and C6. Keep the center conductor short and solder the screen to the ground plane close to the 50 ohm point.

Set the center frequency for the spectrum analyzer, the reference level and the frequency span based on the frequency to be measured. The resolution bandwidth should be 1MHz.

Always start with the component values from the recommended layout.

Follow the flow chart in Figure 2. Adjust the components if the wanted performance is not reached. Adjustments of one component will affect the performance for all parameters. For instance if the output power is too low, and the value of L1 is increased, the harmonic or the LO level might be too high. It is an iterative process. Never change more than one component at a time; else it will be impossible to see the effects of each component. Too low output power and a too high 2nd harmonic are the most common problems. A small increase in L1 normally gives a higher output power and an increase of C6 will decrease the 2nd harmonic. But a too high value of C6 will also affect the output power level.

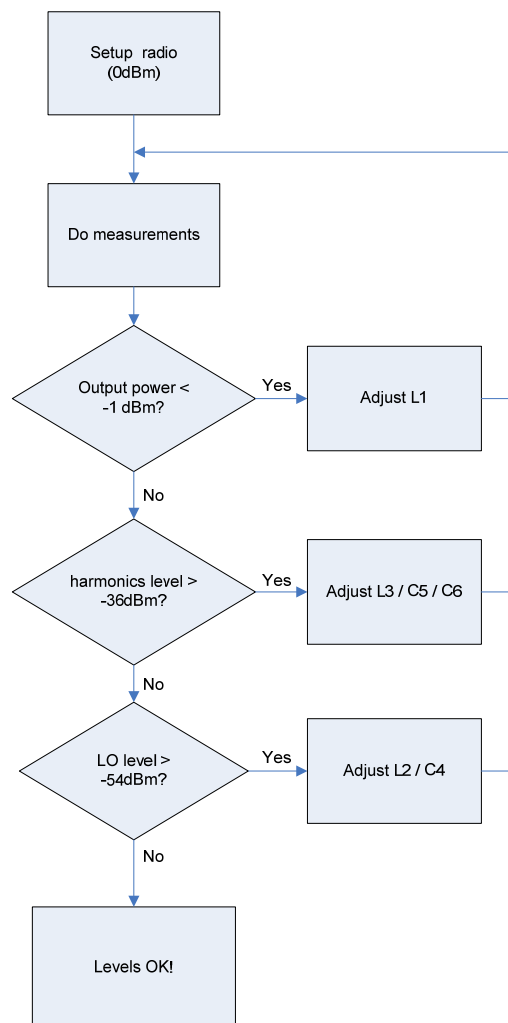

Figure 2- Measurement flow chart



Tuning the nRF24xx matching network

The component values given in the recommended layout on the Nordic Semiconductor web-page can normally be used if the recommended layout is used. But if the layout or the board thickness is changed, some of the components must be changed due to changes in the parasitic effects. The value can be either higher or lower, depending of the stray capacitance and inductance on the board. This also applies if a board with different thickness is used, or if the component size is different from the recommended layout.

The levels for the harmonics and LO given in the flow chart ensures world wide use. The carrier level must be below 0dBm. The harmonics level must be below the outside band spurious level defined by the radio regulations. For world wide use, this is -36dBm. The LO level is defined by the spurious level in RX mode, -54dBm. Please refer to the regulations in the area where the equipment is intended to be used.

The LO frequency in RX mode can be found with this equation:

$$LO = \frac{8}{7}(RF + x) \quad (3.1)$$

Where x is:

nRF2401A	3
nRF24L01	2
nRF24Z1	6

All frequencies are in MHz. RF=Receiving frequency.

Check if the output power level is the same across the band, i.e. measure the power at ch0, ch40 and ch80.

Table 1 shows a suggestion for a measuring series. Write down the changed component value in the same row as the measured values. This makes it easy to track the changes and see the effects of the change. It is necessary to do all the measurements at every component change to see the effects of the change.

When a component is changed, never increase or decrease more than one E12 value at a time.

Some coils are marked in one end, depending on the make. Make sure the direction does not change, as this will affect the performance. The inductor should be tested in both directions and the results noted to find the best orientation. Clearly mark the schematic and the layout with the coil direction for production.

Chip inductors are preferable for mass production due to low cost. Wire wound inductors will have a better performance, but at a higher cost. The reference matching network from Nordic Semiconductor specifies chip inductors. A wire wound inductor will have a higher Q-value and a higher SRF (Self Resonance Frequency). Make sure the inductors have a SRF that is higher than 3GHz. This is especially important if an inductor with a high value is used, as the SRF decreases with the value.



Tuning the nRF24xx matching network

For the capacitors, use NP0 or better quality (+/- 2%) to minimize the variation between samples.

Always use the same component brand/type as in the production. The value of a component is set by the manufacturer, measured at a specific frequency. Different manufacturers are using different methods for this, so even if the value is the same, the effect the component has on the matching network will be different. This is especially important for the inductors.

4. Similarities between devices

Some of the Nordic devices have different matching networks. They all use the same principle, but some have additional tasks.

The nRF2401 matching network is shown in Figure 3. Compared with the nRF24L01 network, C8 and C9 is added and there is a trap formed by C10 and L4. The two caps, C8 and C9, is part of the harmonic filtering. They have been included on the nRF24L01 chip so they have been removed from the matching network for the device. The trap is tuned at LO/2, i.e. half of the frequency from equation 3.1. The LO rejection is improved on the nRF24L01 so the component are not needed.

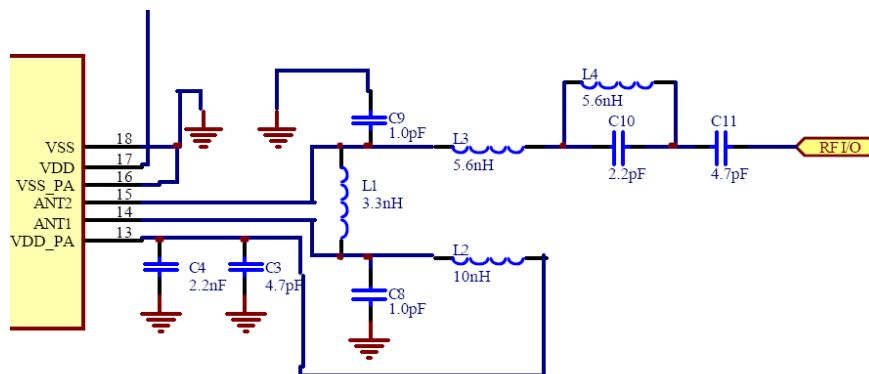

Figure 3- nRF2401 matching network

The same applies for the nRF24Z1 matching network, see Figure 4. The component values are not equal for the different devices. This is because the radio front end is different and different load impedance is needed.



Tuning the nRF24xx matching network

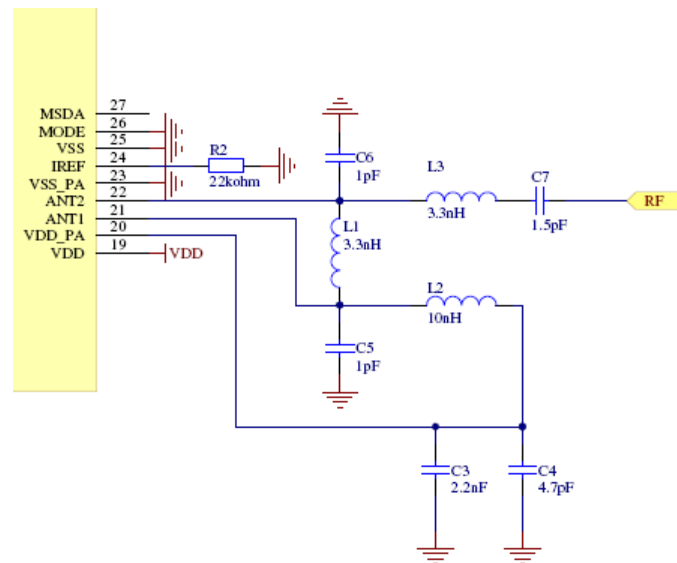

Figure 4- nRF24Z1 matching network

5. Summary

If the performance of the radio module is not as expected, the performance of the matching network must be measured. A decreased performance has several reasons: changed layout of the matching network, different brand/type inductors and so.

The matching network has several roles, like impedance transformation and harmonic rejection, and a number of measurement must be done to be sure the radio complied with the radio regulations.

- Always start with the component values from the recommended layout, found in the datasheet.
- Do the initial measurement to evaluate the performance.
- Follow the flowchart in Figure 2.
- Fill in all the measured values in Table 1.
- Evaluate the changes in performance.
- Change the component values if necessary.
- Always use the same component brand/type as in production.



Tuning the nRF24xx matching network

Series	Component values						Measured values [dBm]								
	L1	L2	L3	C4	C5	C6	RX LO	TX ch0	TX ch40	TX ch80	2.harm	3.Harm	4. Harm	5. Harm	
1															
2															
3															
4															
5															
6															
7															
8															
9															
10															
11															
12															
13															
14															
15															
16															
17															
18															
19															
20															
21															
22															
23															
24															
25															
26															
27															
28															

Table 1- Measuring series



LIABILITY DISCLAIMER

Nordic Semiconductor ASA reserves the right to make changes without further notice to the product to improve reliability, function or design. Nordic Semiconductor does not assume any liability arising out of the application or use of any product or circuits described herein.

LIFE SUPPORT APPLICATIONS

These products are not designed for use in life support appliances, devices, or systems where malfunction of these products can reasonably be expected to result in personal injury. Nordic Semiconductor ASA customers using or selling these products for use in such applications do so at their own risk and agree to fully indemnify Nordic Semiconductor ASA for any damages resulting from such improper use or sale.

White paper. Revision date: 2006-07-10.

All rights reserved ®. Reproduction in whole or in part is prohibited without the prior written permission of the copyright holder.



YOUR NOTES



Nordic Semiconductor - World Wide Distributors

For Your nearest dealer, please see <http://www.nordicsemi.no>



Main Office:

Vestre Rosten 81, N-7075 Tiller, Norway
Phone: +47 72 89 89 00, Fax: +47 72 89 89 89

Visit the Nordic Semiconductor ASA website at <http://www.nordicsemi.no>

