

- [HOME](#)
- [DIY PROJECTS](#)
- [DESIGN IDEAS](#)
- [SCHEMATICS & PICS](#)
- [DISCLAIMER](#)
- [PERSONAL INFO](#)
- [CONTACT](#)
- [SHOP](#)

<http://www.dextrel.net/diyzerocrosser.htm>

DIY - Isolated High Quality Mains Voltage Zero Crossing Detector

- FEATURES:** - very accurate mains zero crossing detection
- fully isolated and low voltage safe output
 - ultra-low power consumption; worst case power dissipation < 120mW
 - produces symmetrical pulses around the zero crossing
 - very low parts count, no precision components required
 - all components can be low voltage SMD
 - works over all mains voltage ranges (100VAC...240VAC), without any modification
 - both 50Hz (1ms ZC pulse) and 60Hz (0.83ms ZC pulse) mains frequency compatible
 - highly stable with varying temperature

AVAILABLE DOWNLOADS:

RESTRICTIONS:

none
none (free use)

The Project

Modern electronic equipment are nowadays typically powered by switch--mode power supplies. Due to their high frequency operation, these PSU's have no means of providing mains frequency (and/or phase infor-mation) for the low voltage electronics circuitry on the se safe low voltage seconda-ry side. Devices such as lighting con-trollers, thermostats, motor drives and similar AC-load controlling or monitorin applications, often needs mains phase and/or frequency information. Adding an old type iron core mains transformer for this purpose would be both expensive and clumsy. A suitable zero crossing circuit is often needed. This DIY project presents one very clever variety of such a zero crossing detector, invented by the author.

Fig. 1 shows a low parts count and low power isolated ac-line zero-crossing detector circuit.

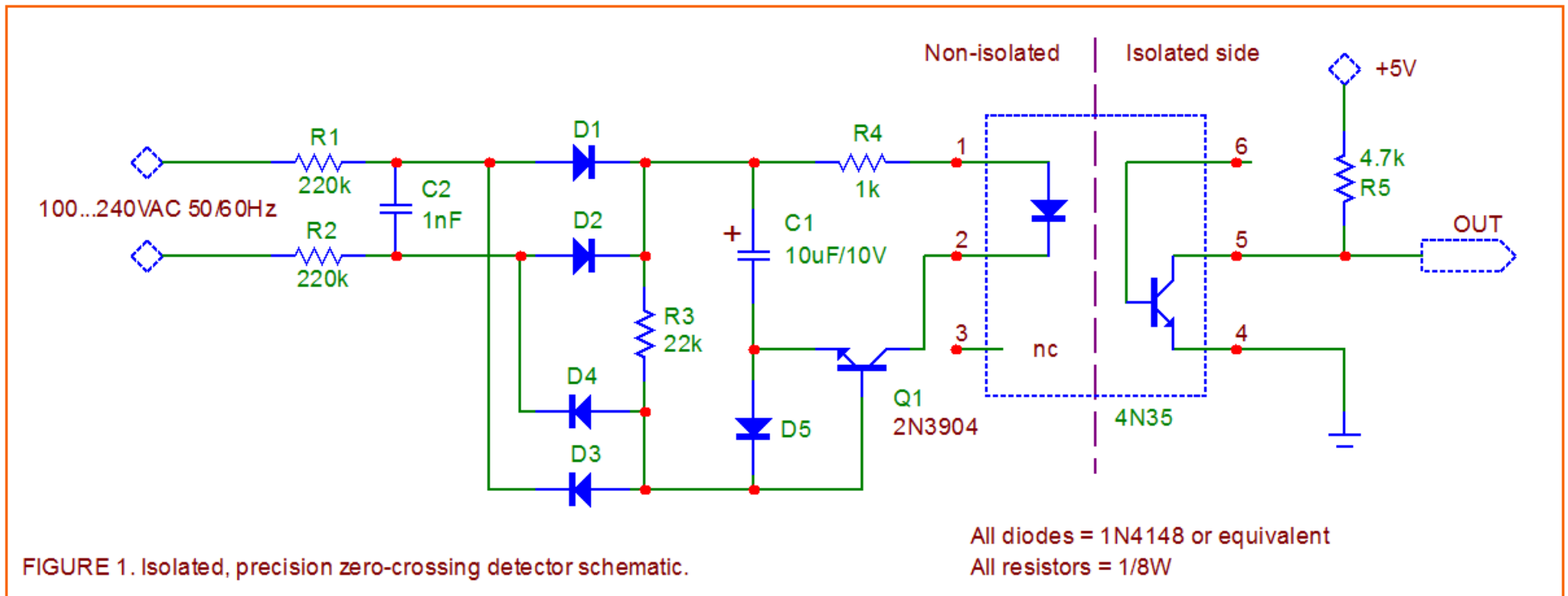

OTHER KNOWN ZC-DETECTORS

The Design Idea “Isolated circuit monitors ac-line” published in EDN the 5th of July 2007, is primarily intended for mains line ac-voltage measurement, and is not optimal for efficient zero-crossing detection. The Design Idea “Improved opto-coupler circuits reduce current draw, resist LED aging”, published 14th of December 2007, also suffers from unnecessary complexity and cannot produce the often required symmetrical zero crossing pulses for proper thyristor or triac firing.

THIS CIRCUIT

The circuit presented here produces constant and well defined zero crossing pulses, centered symmetrically around the zero crossings, using very little power and just a few plain vanilla components. The pulse length is virtually independent of the mains voltage, is stable with temperature, and immune against component and opto-coupler tolerances and aging. A perfboard prototype is presented in the picture.

DETAILED DESCRIPTION

The zero crossing circuit consists of the voltage to current converting resistors R1-R2, full-wave rectifier diodes D1-D4, a voltage averaging and storing capacitor C1, the opto-coupler U1, and transistor Q1 that functions as a voltage comparator. R3 provides base current for Q1, and doubles as an input voltage divider together with resistors R1-R2. R4 limits and sets the current into the opto-coupler LED. D5 provides a proper charge current path for C1, preventing the reverse-biasing of the Q1 b-e junction.

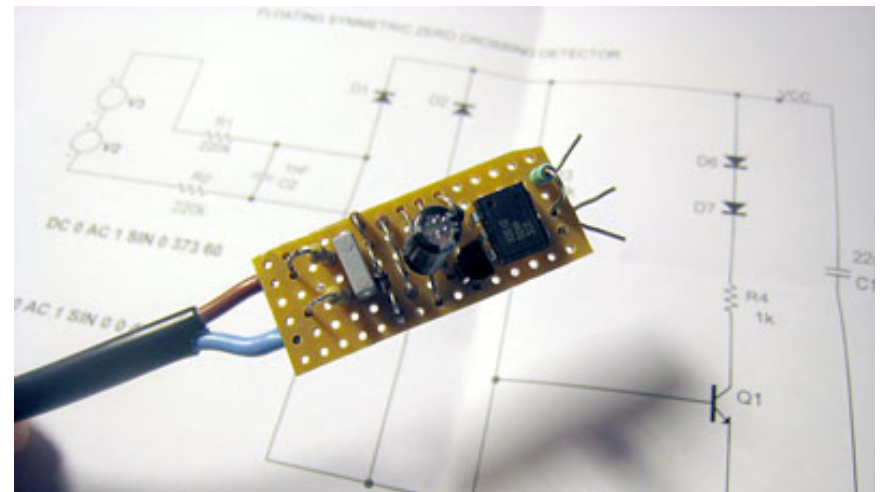

Transistor Q1 stays off during the majority of the mains cycle, during which C1 is charged via R1-R2 and D5. Q1 turns on and feeds current from C1 to the opto via R4, whenever the mains voltage (divided by $(R1+R2)/R3$) is lower than the voltage across C1. The voltage across C1 will reach within about 400ms an equilibrium that defines the final operating point. The voltage across C1 never exceeds 10 volts with the given resistor ratios. The voltage stabilizes at a point when the average current charged equals the average current consumed. The typical pulse width is 1ms at 50Hz, and 0.83ms at 60Hz, when using the component values shown. The output pulse width is fairly constant, independent of the designated AC-line voltage (90... 240VAC). This makes this simple zero crossing detector quite unique, since the mains voltage does not affect the pulse width nor its position.



The circuit's total power consumption is a mere 32mW at 120VAC, and barely 120mW at 240VAC. The majority of this power is dissipated in the input resistors R1-R2. The peak current flowing into the optocoupler LED varies almost linearly with the mains voltage. This does not cause any inaccuracies to the zero crossing function, as long as the opto-coupler output is always allowed to saturate - even at the lowest mains voltage. This factor determines the minimum allowed value of the pullup resistor R5. The 4N35 optocoupler has a guaranteed CTR (Current Transfer Ratio) of 100%. If you use another optocoupler, please consider this when calculating the minimum value for R5. You cannot increase the current fed into the optocoupler led by decreasing R4, if you do not at the same time decrease the total resistance of R1 and R2 with the same ratio. The component values given here are optimized for the best signal quality at the lowest possible power dissipation.

C2 forms a first-order low pass filter to deal with the real world noisy power lines. By decreasing the $1/f$ frequency of this filter you can deliberately delay the ZC-pulse.

All components are low cost and low voltage types ($<10V$), with the exception that R1 and R2 must sustain each half of the maximum peak mains voltage (200 volts). R2 can be omitted if R1 alone can sustain the maximum peak input voltage. In this case use a 390kohm standard resistor. Splitting the input resistor into two (halving the voltage handling requirement) makes it possible to use only SMD-components.

The oscilloscope screenshot shows the quality and symmetry of the output pulse. The "downhill" trace is the mains voltage at 20V/div vertical scale, zero volts is at the screen centerline. The other trace is the output with a 5V/div scale factor. The timebase is 500 μ s per division. The output pulse is beautifully symmetric around the mains zero crossing.

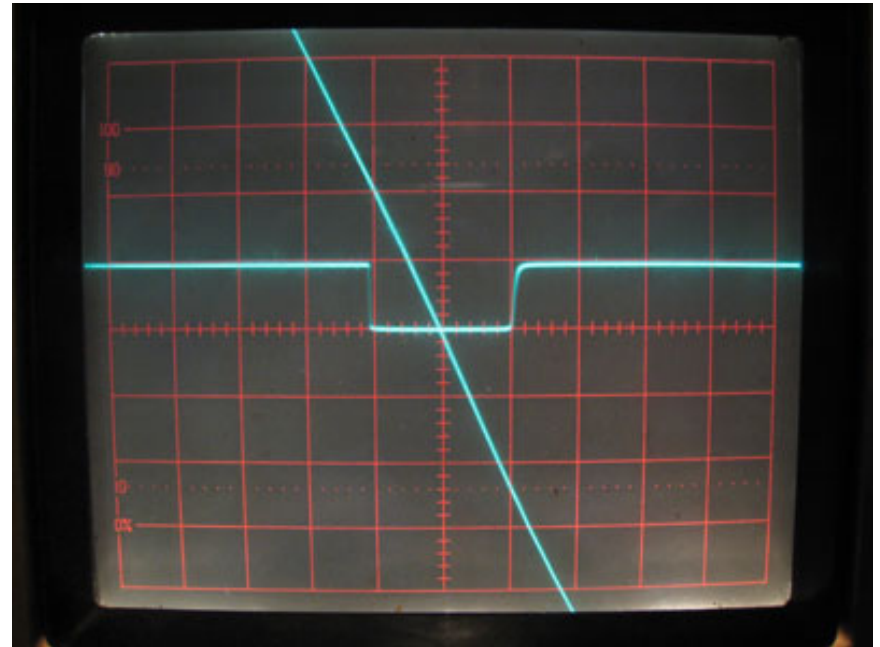

Even huge temperature variations have a minuscule effect on the zero crossing pulse, due to the "self-biasing" nature of the circuit. The tolerance of C1's capacitance has no effect either. The circuit's resistor ratios set mainly the operation point, and that is the reason is why the output pulse is almost temperature independent.

The picture on the right is a simulated response for two extreme mains voltages (100VAC...240VAC). You can see that the pulse width variation is minuscule, being less than 100us over the whole mains voltage range. Real behaviour of the actual circuit is equal.

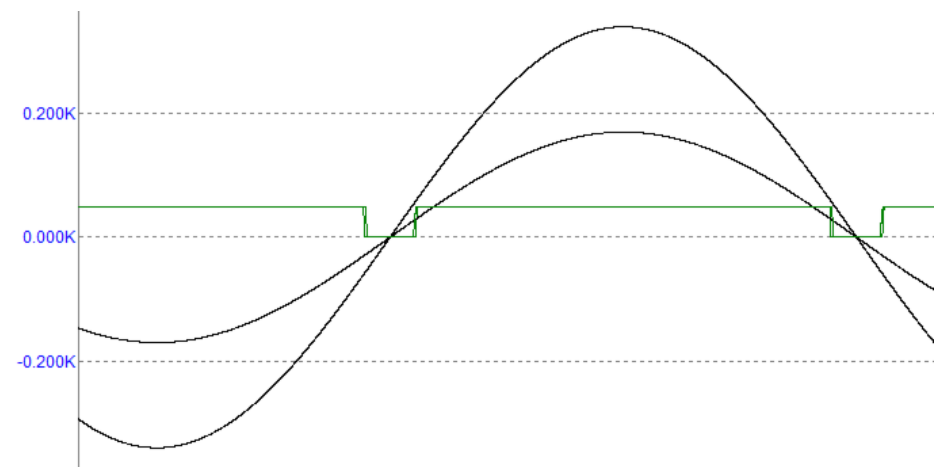

OTHER USES - LOAD MONITORING

Sometimes you don't need to monitor the mains itself, but you need to monitor a controlled mains load. Also here the ZC circuit come in handy. An example is shown in Fig 2. Here a triac controls an incandescent bulb either on or off. With the help of the ZC you can monitor a shorted load, an open load, missing live voltage, and also that the triac is working properly. "

When the power to the load is switched off:

There is always a small leakage current via the triac snubber, even if the triac is off. This current is effectively shorted by the load, thus the ZCD sees no voltage and does not produce output pulses when the load is connected. If the load becomes disconnected or the bulb filament has failed, then the snubber leakage current is high enough to produce ZC-pulses even if the triac is off. This way you can check the condition of the bulb without adding cumbersome current measurement circuits, and get a warning if the load has failed.

When the power to the load is switched on:

During this time the ZCD must produce pulses - if not - then the triac has failed or the live voltage is missing (possibly a blown fuse earlier in the circuit).

By combining ZCD information with the triac drive status, you will be able to detect failures in driving a load. Any critical loads (such as alarm lights, traffic lights) can benefit from load monitoring.

OTHER USES - AC MOTOR MONITORING

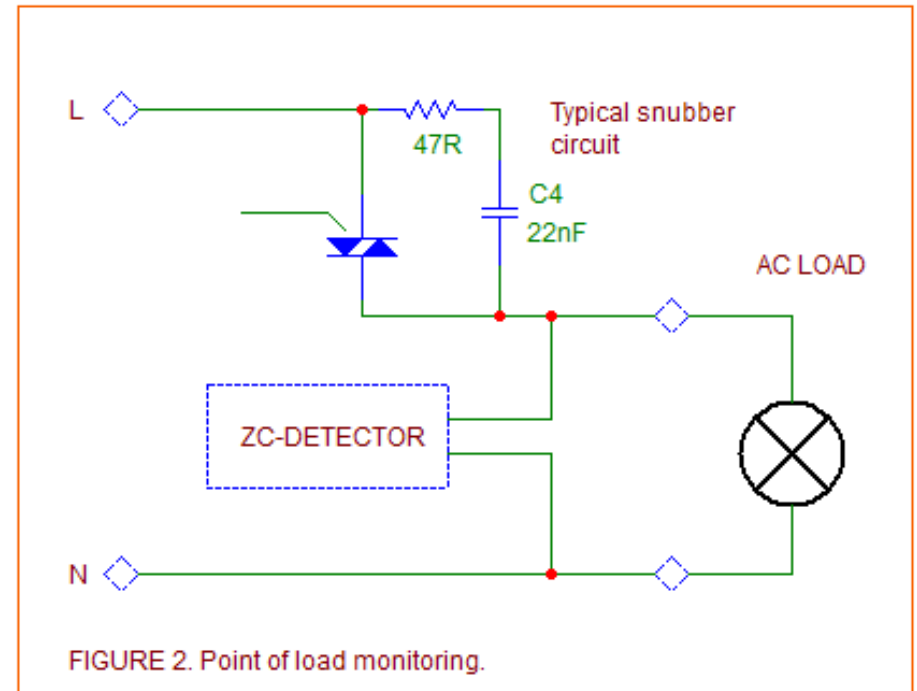
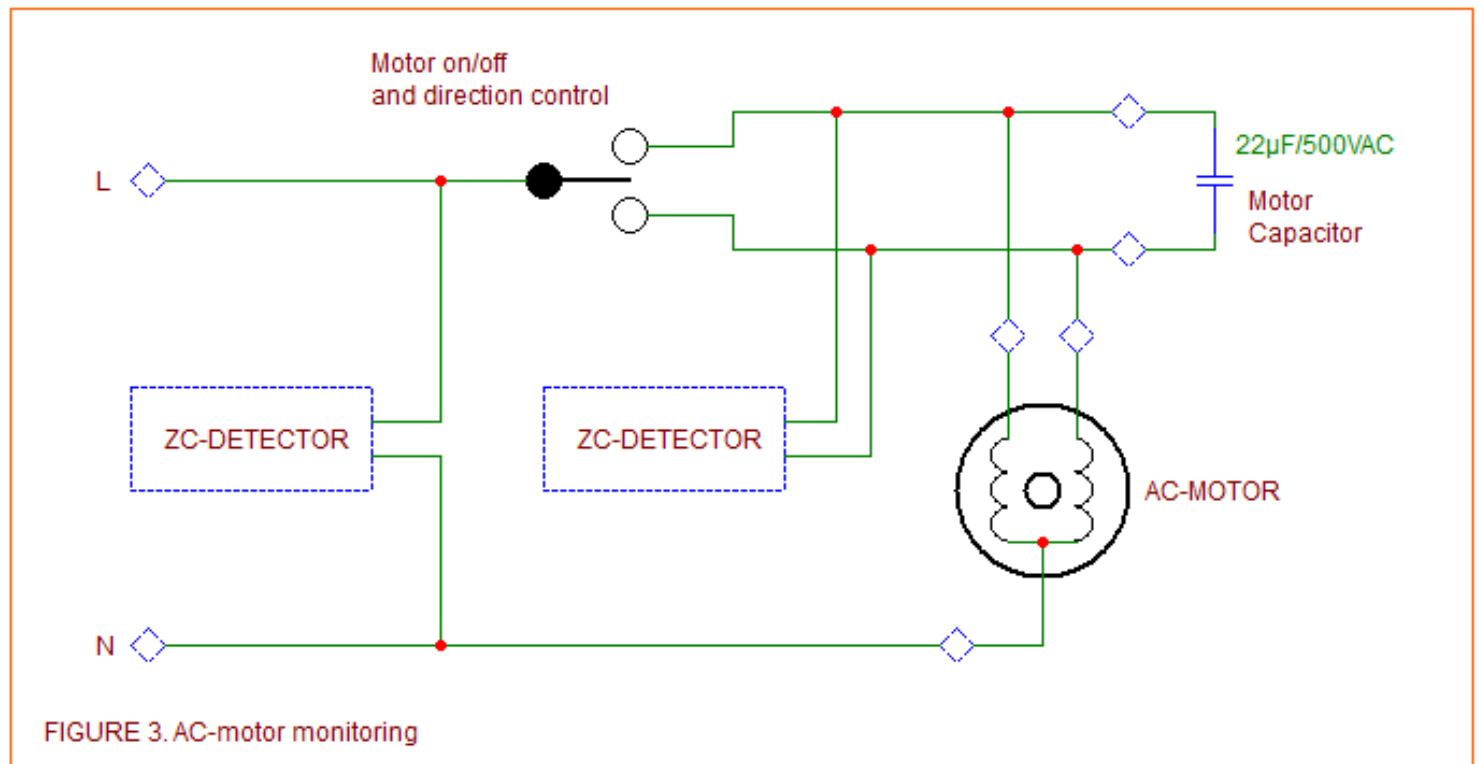

FIGURE 2. Point of load monitoring.

Running an 1-phase AC motor and knowing that the motor actually rotates can also easily be monitored by using two ZC detectors. This quite unique but simple idea using only two simple ZC detectors can actually monitor many types of failures, including; open or short circuits in any winding or wires to the motor, open or short circuits in the motor capacitor or its wires, relay, triac and fuse failures. Even a stalled rotor can be detected. Any of these failures will cause the motor not to rotate, and this condition can be sensed as explained below.

You need a microprocessor to perform the logic, but the circuitry is otherwise simple. To power the motor on or off, you can use the circuitry in Fig 2, and use Fig 3 as the load. It is recommended to use a triac to control the motor power, and a relay (preferably two) to control the direction of the motor (if needed). To prevent relay contact damage the relay(s) should change state only when the triac is off and the motor standing still.



The first ZC detector that is connected straight across the input (between L and N) monitors the incoming voltage (and thus also checks the proper triac operation and the availability of the mains voltage or blown fuses). The second ZC detector detects the zero crossing BETWEEN the motor phases. This ZC pulse is time delayed from the mains zero crossing by a certain amount of time and depends on the motor inductance and motor capacitance tolerance. On a 50Hz mains frequency the phase shift of typically 90 degrees would produce a delay of about 5ms. Both ZC signals should be connected to a microprocessor's input capture pins. By teaching the microprocessor the time delay and it's allowed time variance, you can check with 100% certainty that the motor is rotating, even without any tachometry feedback from its axle. Any failure mentioned above would either cause the pulses from the ZC detector (between the motor phases) to be missing completely, or the phase relationship referenced to the mains zero crossings to differ considerably. With the help of the microprocessor logic, you can thus build a rotation failure warning system for any mains operated 1-phase motor.

Amazing what you can achieve with only a few creatively inter-connected components!

OTHER NOTEWORTHY OBSERATIONS

This zero crossing detector takes a while to start because C1 must first be charged to its equilibrium voltage. This takes about 200 to 400ms, depending on the mains voltage. However, after this period the circuit works normally and reacts immediately to missing mains voltage cycles.

This ZCD can thus be used for other specific purposes, for example as a missing mains cycle detector, as a pulse-length discriminator, as a AC-load monitor, as a mains fuse condition detector, as an AC-motor function monitor, to mention a few. Connecting the phase detector between the phases of a 1-phase motor will produce somewhat higher voltages than the mains, and you have to make sure that the combined voltage and power rating of R1 and R2 is high enough.

This DIY page is still under construction. As usual, your feedback is more than welcome: [SEND MESSAGE](#)

G

2011 - Copyright (C) Dextrel Electronics