

REVISION HISTORY

REV	Description	DATE	BY
REV C	Baseline Version: TWL4030_PWR_SCH, Rev-B 1) TPS- All LDO power output (both internal & external) capacitors are changed from 0.1uF to 1uF. 2) 10K pull down added for ADCIN2, ADCIN3, ADCIN4, ADCIN6, START.ADC, MSECURE signal 3) 100uF decap added for VBAT; 10uF added between CP.IN & CP.GND 4) TEST.RESET, VMODE1 connected to GND through 10K 5) nSLEEP1 signal connected to SYS_OFF_MODE of OMAP 6) VPLL2 net name changed to VSDI.CSI.OUT 7) VDD1.L net name changed to VDD1.SW & VDD2.L net name changed to VDD2.SW 8) An additional connector is added to route Audio & Keypad signals. Backup Battery Added 9) Pull up for HSUSB_CLK and pull down for HSUSB_DATA6 are made DNI.	28-MAY-09	Mistral
	Review Comments Updated	28-MAY-09	Mistral
REV D	1) R46 is added. GND_POWER and GND has connected through 0 Ohm, 0402 2) GPIO changes made MUX -> MUTE, HS DETECT -> MUX & MUTE -> HSDetect	30-JUNE-09	Mistral

TABLE OF CONTENTS

Page No	Schematic Page
01	Cover Page
02	OMAP EVM Main board Connectors
03	TPS65950 -Part A
04	TPS65950 - Part B



PRELIMINARY documents contain information on a product under development and is issued for evaluation purposes only. Features characteristic data and other information are subject to change.

Texas Instruments Incorporated
 Broadmarket OMAP Support Team Under Non Disclosure Agreement
 12500 TI Blvd
 Dallas, TX 75243
TI - Proprietary Information
Do Not Copy

Cover Page **OMAP 35x EVM Power Module**

Size B	Document Number TPS65950_PWR_SCH	Modified by: Mistral	Rev D
-----------	-------------------------------------	-------------------------	----------

Date: Wednesday, October 28, 2009 Sheet 1 of 4

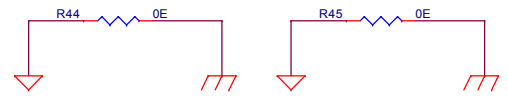
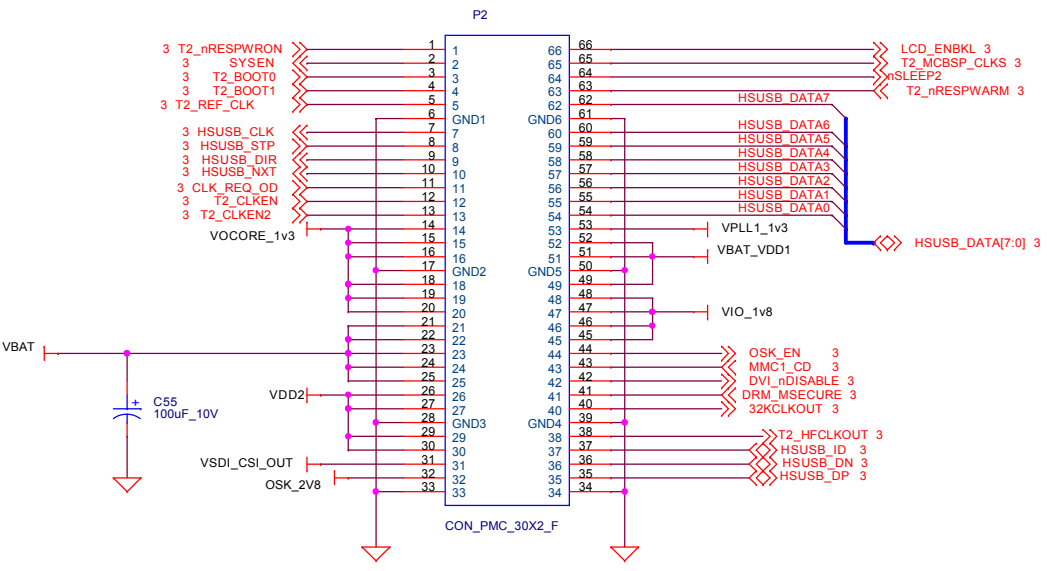
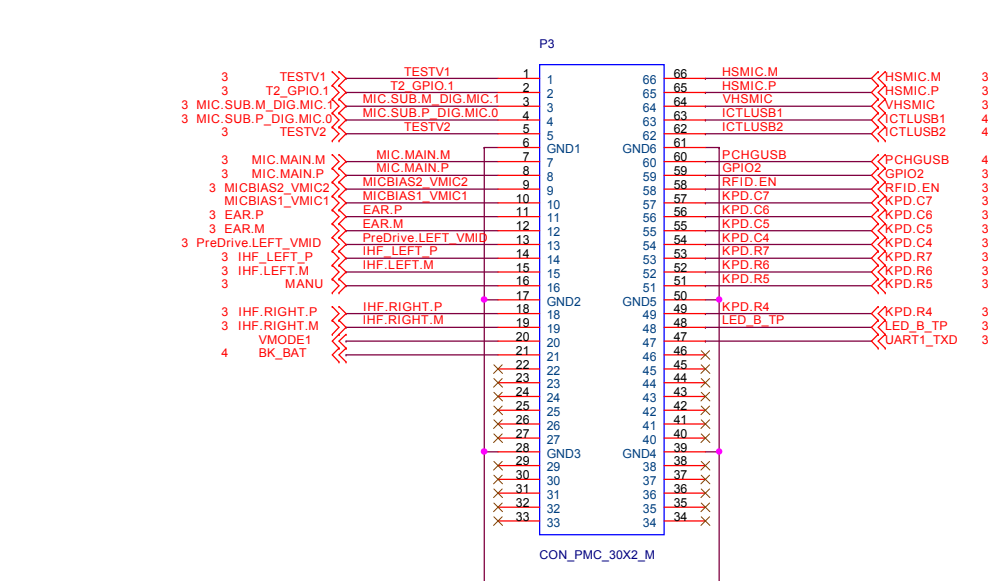
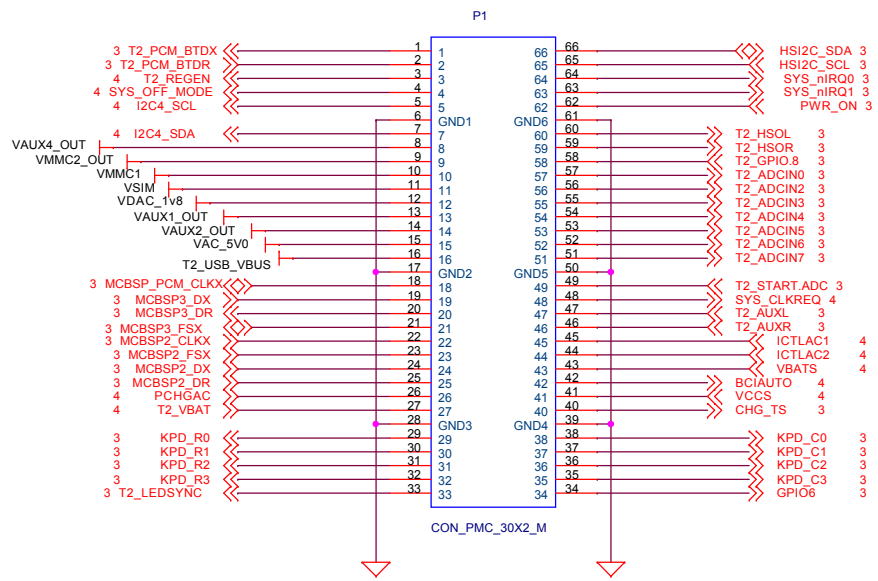

Texas Instruments Incorporated
 Broadmarket OMAP Support Team *Under Non Disclosure Agreement*
 12500 TI Blvd
 Dallas, TX 75243

*TI - Proprietary Information
Do Not Copy*

PRELIMINARY documents contain information on a product under development and is issued for evaluation purposes only. Features characteristic data and other information are subject to change.

Cover Page		OMAP 35x EVM Power Module	
Size	Document Number	Modified by:	Rev
B	TPS65950_PWR_SCH	Mistral	D
Date:	Wednesday, October 28, 2009	Sheet	2 of 4

