

REVISION HISTORY

REV	Description	DATE
REV E	Base Line version : OMAP35X_EVM_MB_SCH, Rev-D 1) Connected SYS_BOOT5 to ENET_nRST. 2) Filtering capacitors added on the touch panel X/Y lines 3) Battery charging section cleaned up 4) USB VBUS circuitry changed to provide up to 500mA 5) audio Headset detect Circuitry Added 6) DRM_MSECURE connected to GPIO 7) On board MDC Support 8) On board Camera Support 9) WL1271 Support	06-MAY-09
	Review comments updated	28-MAY-09
REV F	3-Pin Header Added to Enable/Disable AC Charger Ethernet Section: R822 - DNI, EEPROM Changed to 93AA46A-I/SN Touch Screen Section: C147, C148, C149 & C150- DNI	30-JUN-09
REV G	1) WLAN Support through 60-Pin connector removed 2) Camera connectors added for Micron connector, LI connector & LI 3-MPixel Module 3) EHCI: 1.8V Power rail sourced from VAUX2 4) OTG VBUS Switch control from ISP1507 (500mA Support) 5) JFFS2 issue fix: nCAM_VD_EN signal changed from GPIO_62 to T2_GPIO8	28-AUG-09
	Review comments updated 1. Series Termination added for GPFC_CLK 2. Make D14, D15, D30 & D31 as DNI	01-SEP-09

TABLE OF CONTENTS

Page No.	Schematic Page
01	Cover Page
02	Power Distribution
03	TPS65950 Power board connectors
04	OMAP Processor board connectors
05	Ethernet Interface and Clock Distribution
06	LCD Panel, Touchscreen & Backlight
07	DVI Interface
08	SD/MMC, Audio and Keypad Interfaces
09	Expansion Module Connectors
10	UART Interface
11	ETM & JTAG Interfaces
12	HSUSB OTG Interface
13	HSUSB Transceiver and USB
14	Video Decoder Interface
15	Video-IN Multiplexing
16	Transceivers & Switches
17	On Board Camera Interface
18	Micron Connector Transceivers
19	Micron & LI Camera Connectors
20	Miscellaneous

DC Wall Supply Section

DC Power Supply:
Voltage = 5.0V +/- 5%
Current = 3.0A Max

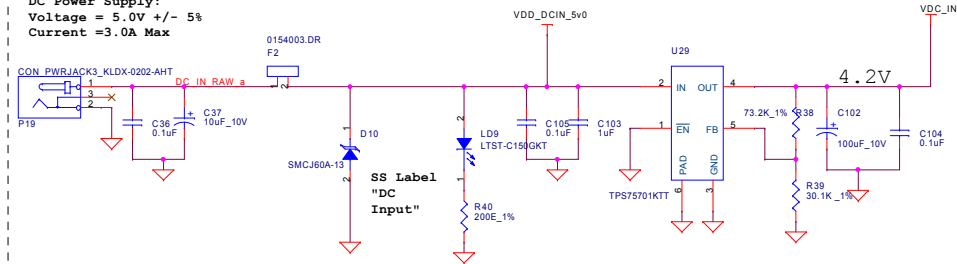

Power for the Ethernet, DVI, JTAG domain

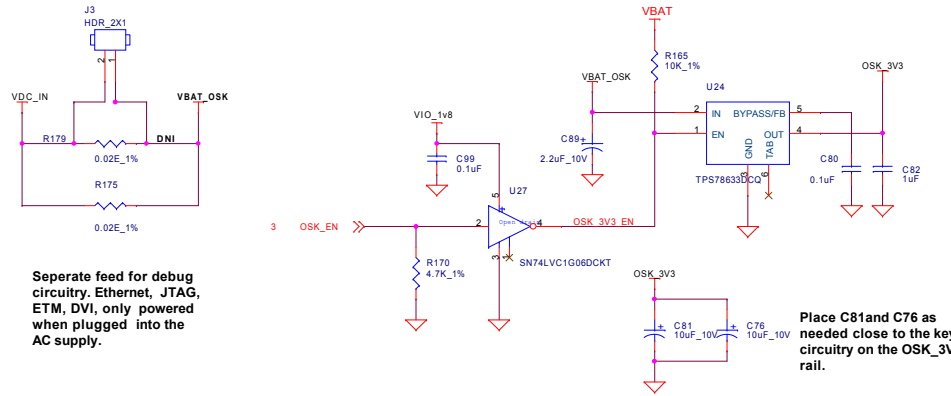

BATTERY CHARGER SECTION

SS Label
"AC-Charger EN
AC-Charger DIS"

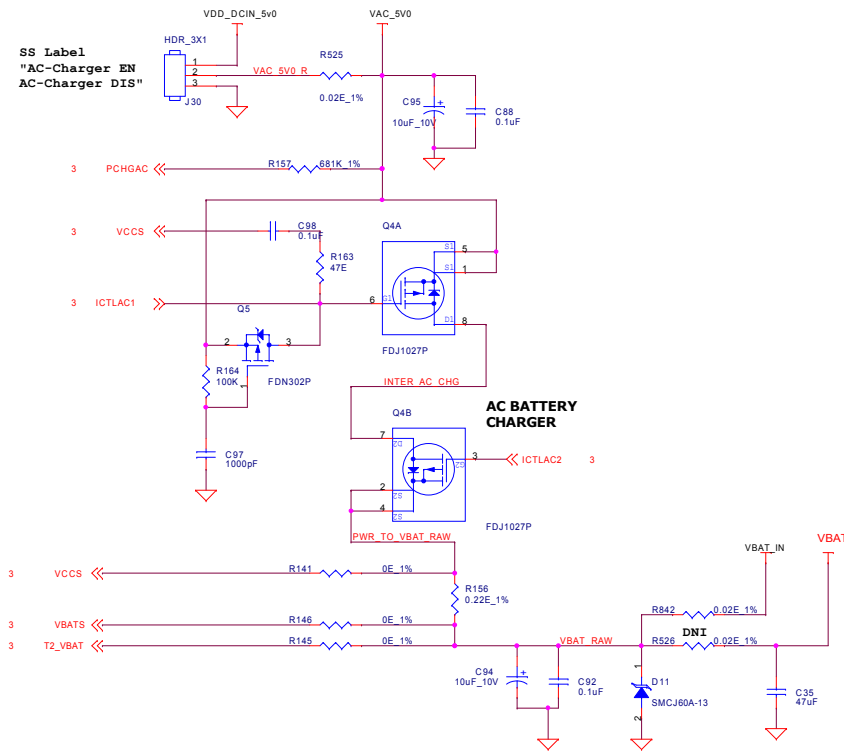

Bi-directional level translator for HDQ I/F

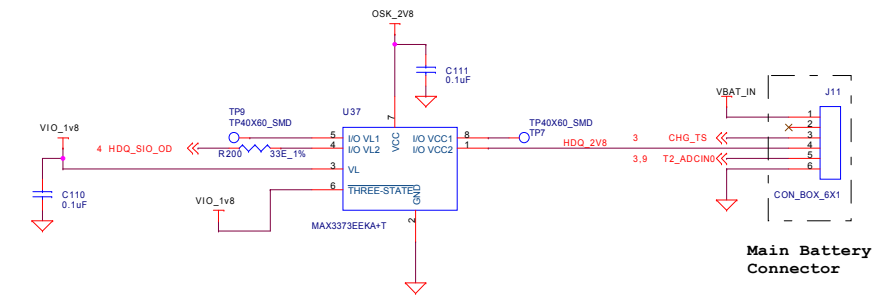

BATTERY INPUT SELECTION

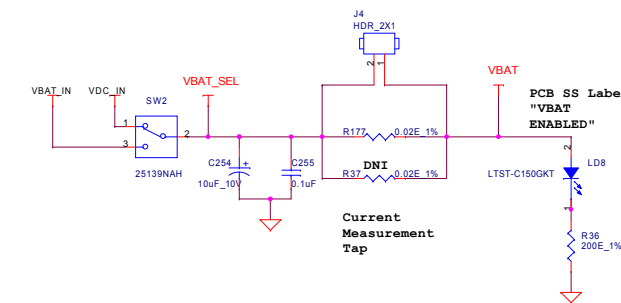

GND Probe points

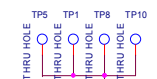

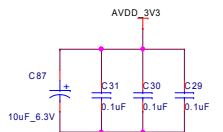
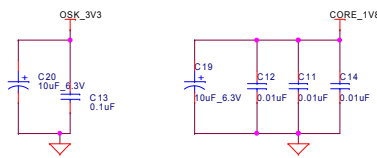

Place close to U66

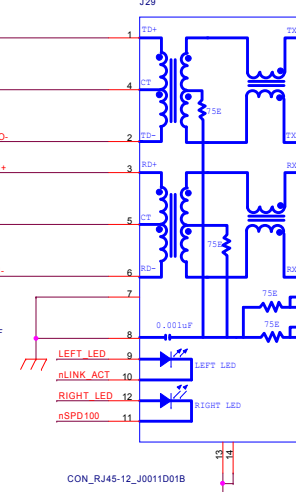
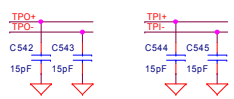
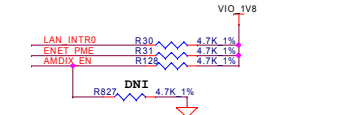
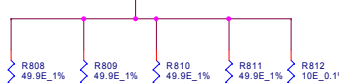
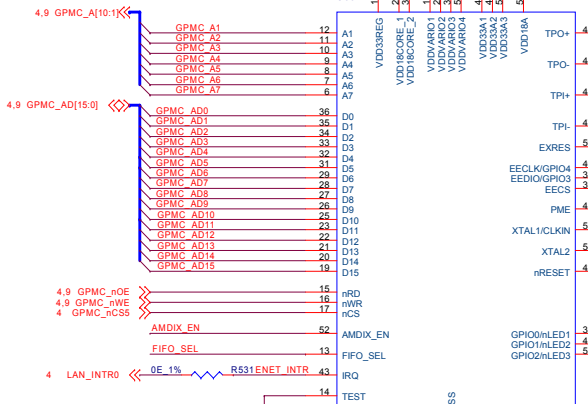
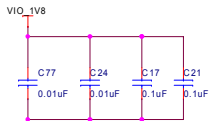

CON_RJ45-12_0001D01B

26MHZ Clock Section

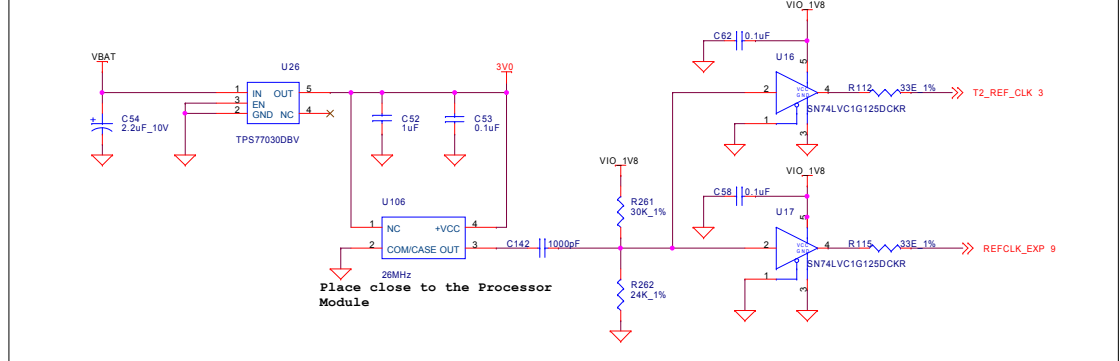

Place close to the Processor Module

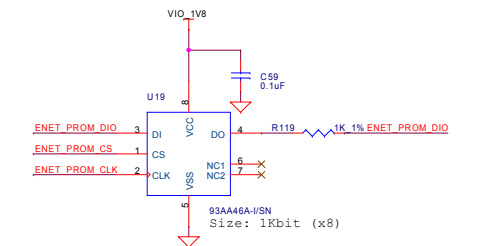

		Texas Instruments Incorporated Broadmarket OMAP Support Team Under Non Disclosure Agreement 12500 TI Blvd Dallas, TX 75243	
		<i>TI - Proprietary Information Do Not Copy</i>	
OMAP35x EVM MAIN BOARD Ethernet, Clock			
Size	Document Number	Modified by:	Rev
C	OMAP_EVM_MAIN_BOARD_SCH	Mistral	G
Date:	Tuesday, September 15, 2009	Sheet	5 of 20

LCD Panel, Touchscreen, & Backlight

Place Close to the Processor

LCD Buffers/Translators

Place Close to the Buffer

Place LCD ground shield under the LCD. Tie it back to the DC input ground connection.

TOUCHSCREEN

LED BACKLIGHT

3.3V LCD Power

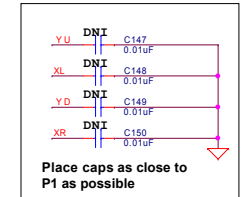
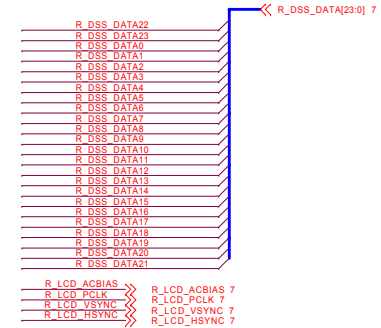
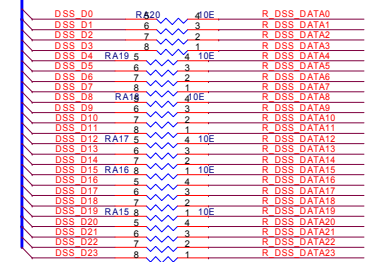

PRELIMINARY documents contain information on a product under development and is issued for evaluation purposes only. Features characteristic data and other information are subject to change.

Texas Instruments Incorporated
 Broadmarket OMAP Support Team Under Non Disclosure Agreement
 12500 TI Blvd
 Dallas, TX 75243

OMAP35x EVM MAIN BOARD
 LCD interface

Size	Document Number	Modified by:	Rev
C	OMAP_EVM_MAIN_BOARD_SCH	Mistral	G

Date: Tuesday, September 15, 2009 Sheet 6 of 20

TI - Proprietary Information
 Do Not Copy

DVI Buffers/Translators

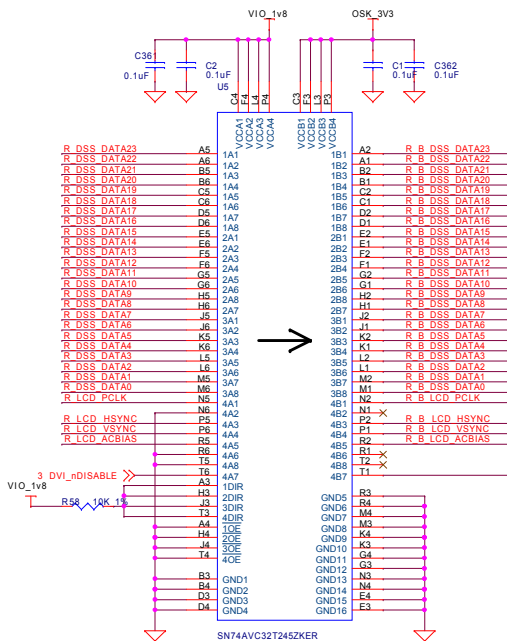

DVI Interface

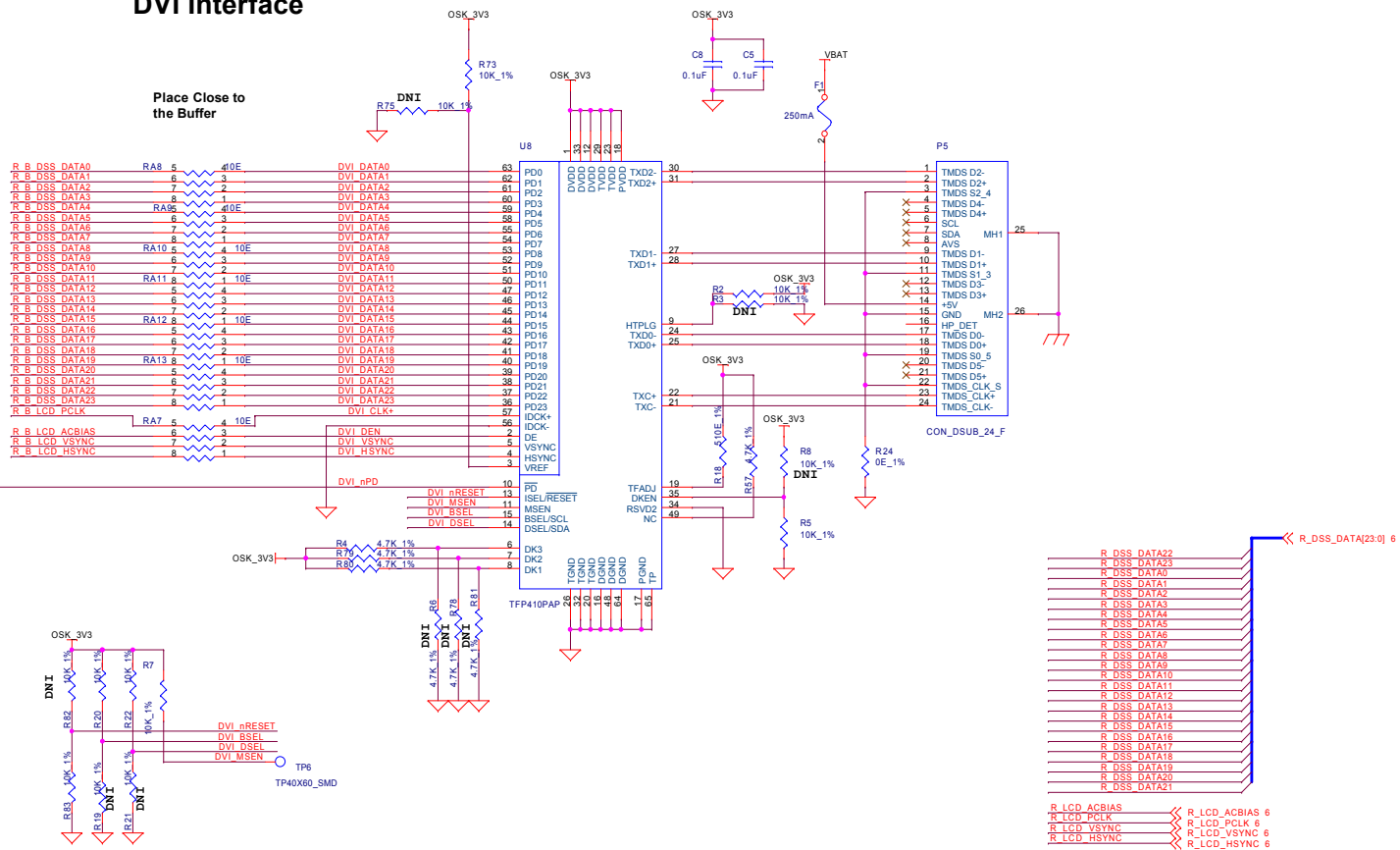

**TEXAS
INSTRUMENTS**

Texas Instruments Incorporated
 Broadmarket OMAP Support Team Under Non Disclosure Agreement
 12500 TI Blvd
 Dallas, TX 75243
*TI - Proprietary Information
 Do Not Copy*

OMAP35x EVM MAIN BOARD
 DVI Interface

Size	Document Number	Modified by:	Rev
C	OMAP_EVM_MAIN_BOARD_SCH	Mistral	G
Date: Tuesday, September 15, 2009		Sheet	7 of 20

PRELIMINARY documents contain information on a product under development and is issued for evaluation purposes only. Features characteristic data and other information are subject to change.

Stereo In 3.5mm Jack

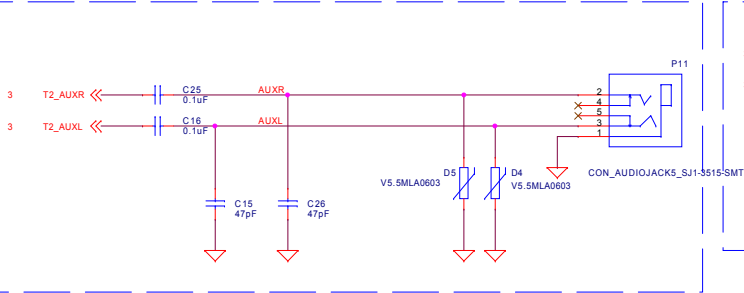

Stereo Out 3.5mm Jack

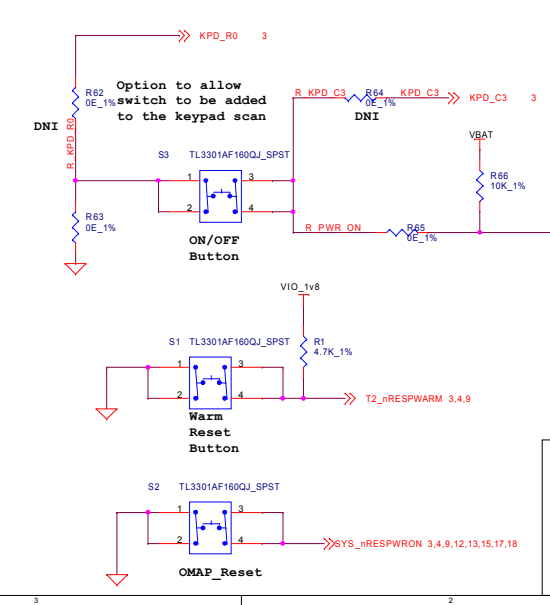
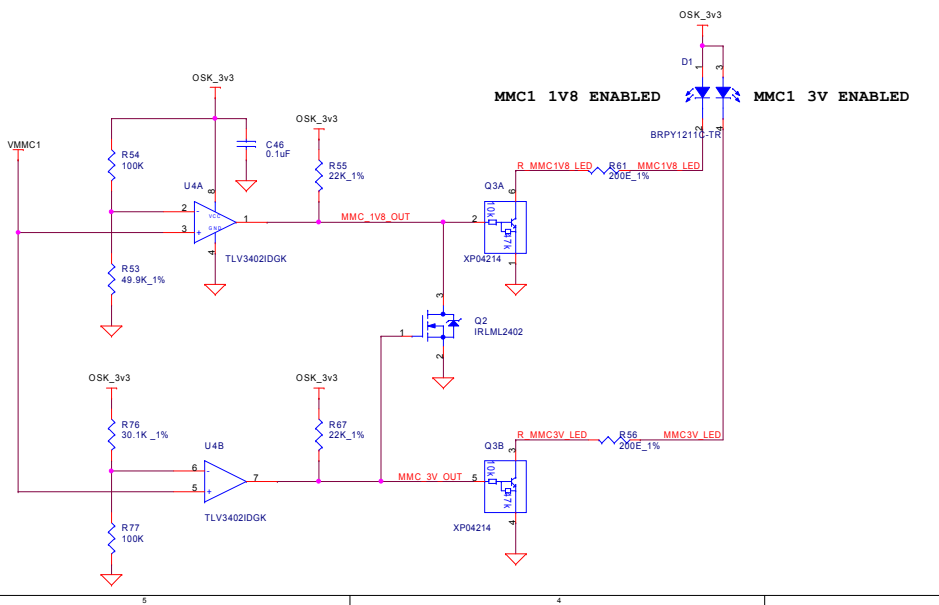
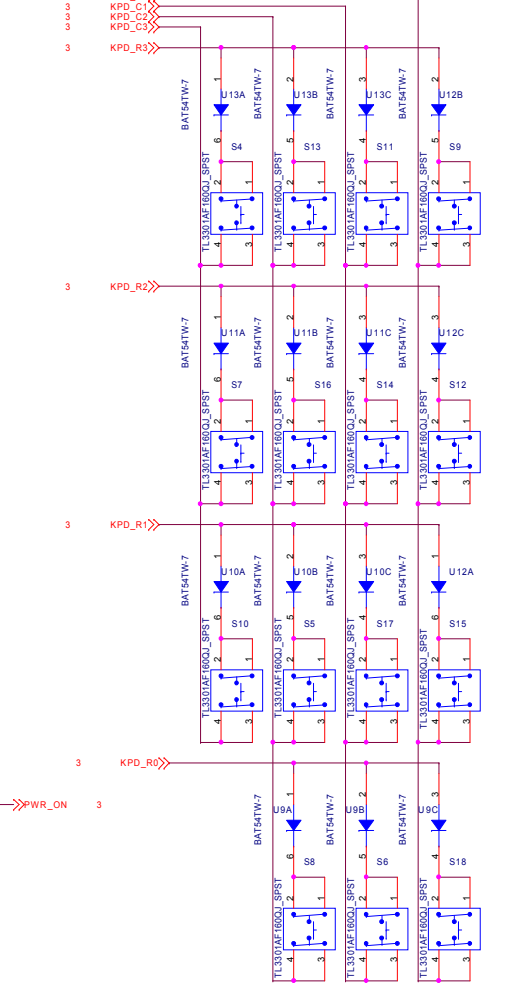
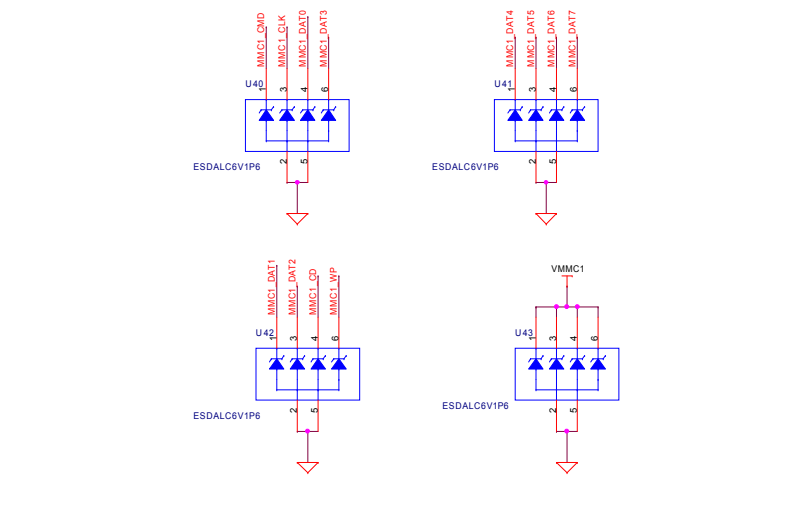
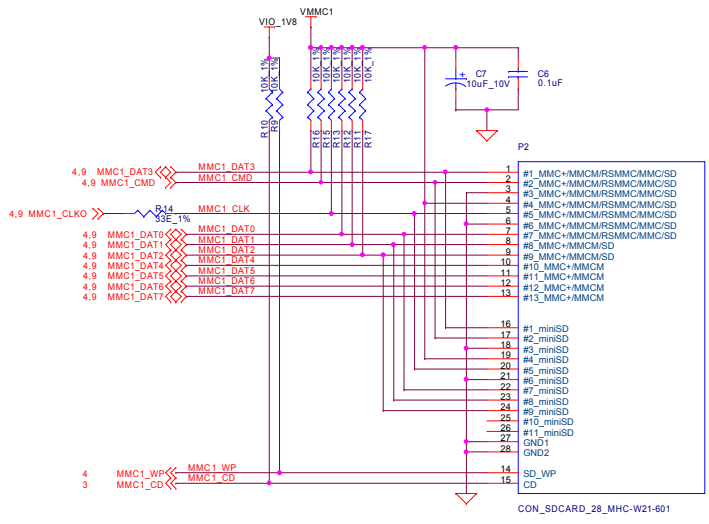
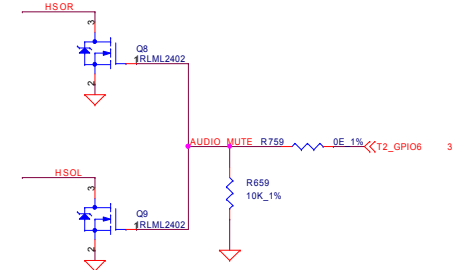
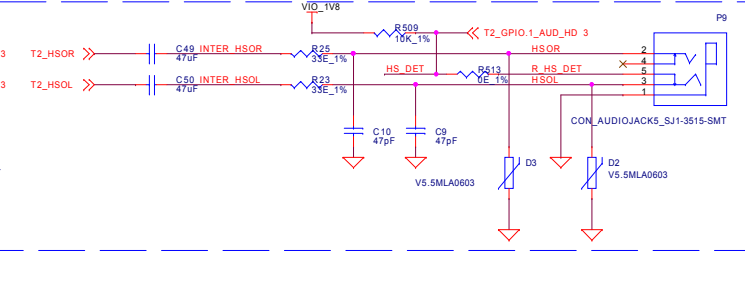

TEXAS INSTRUMENTS

Texas Instruments Incorporated
 Broadmarket OMAP Support Team Under Non Disclosure Agreement
 12500 TI Blvd
 Dallas, TX 75243

PRELIMINARY documents contain information on a product under development and is issued for evaluation purposes only. Features characteristic data and other information are subject to change.

OMAP35x EVM MAIN BOARD
 MMCSD, Audio, Keypad

Size	Document Number	Modified by:	Rev
C	OMAP_EVM_MAIN_BOARD_SCH	Mistral	G

Date: Tuesday, September 15, 2009 Sheet 8 of 20

GP Expansion Connector 1

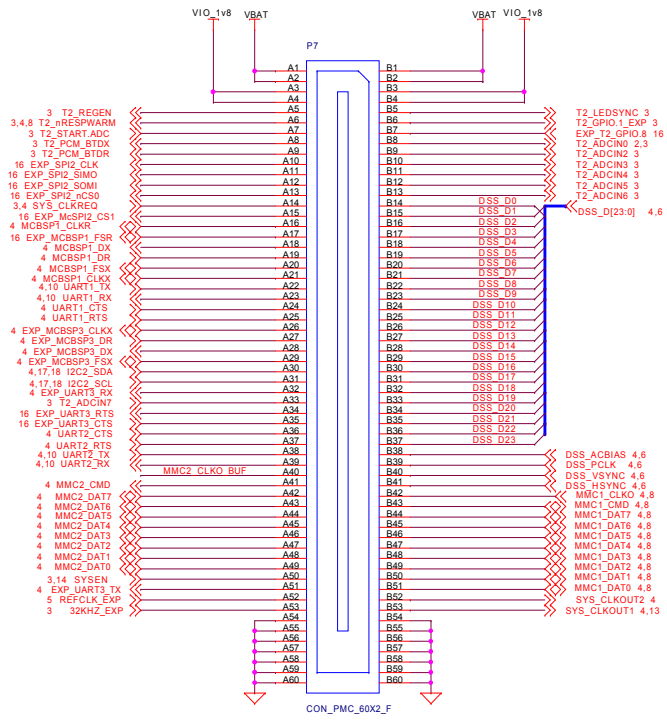

GP Expansion Connector 2

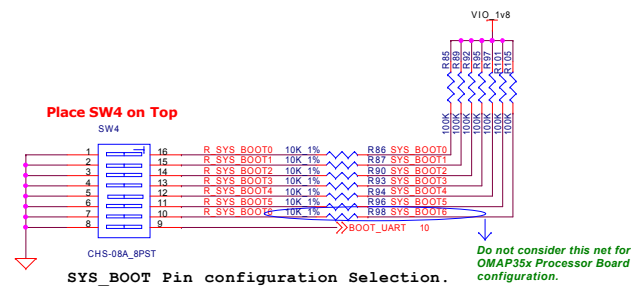
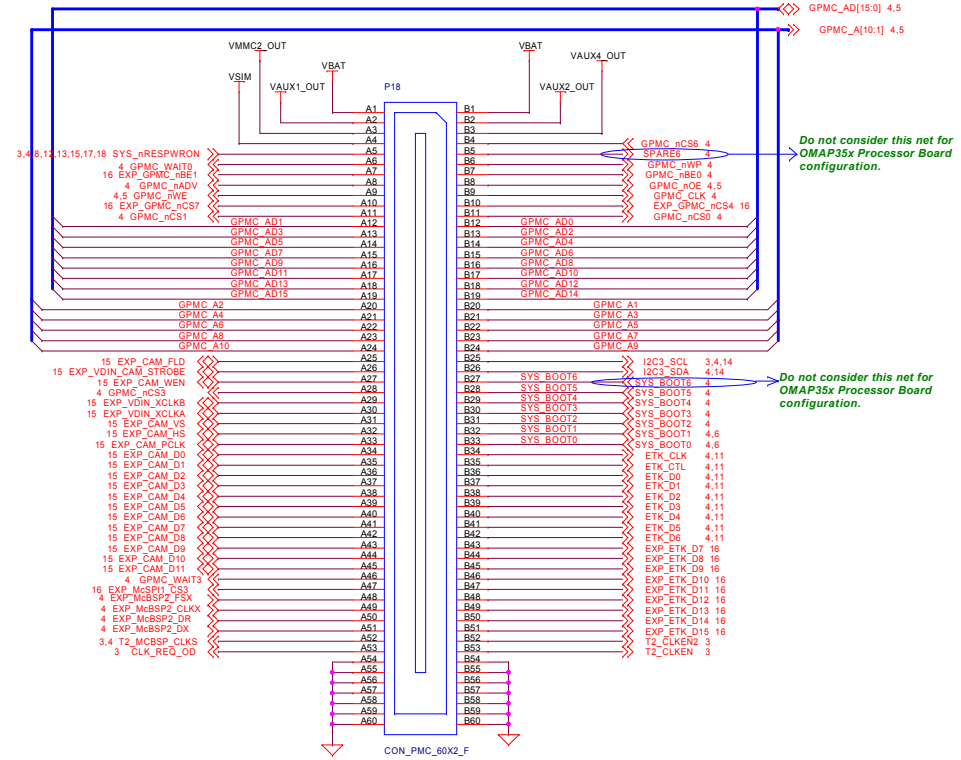

CVBS TV Out

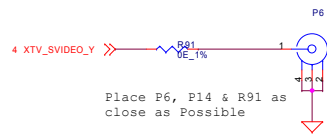

S-Video Out

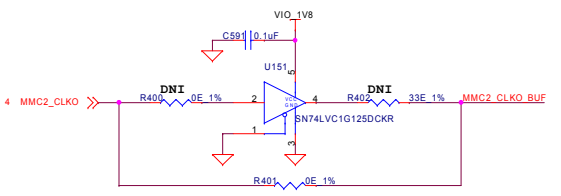
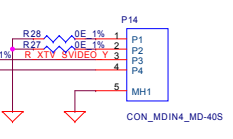

TEXAS INSTRUMENTS

Texas Instruments Incorporated
 Broadmarket OMAP Support Team Under Non Disclosure Agreement
 12500 TI Blvd
 Dallas, TX 75243
 TI - Proprietary Information Do Not Copy

OMAP35x EVM MAIN BOARD
 Expansion Connectors

Size	Document Number	Modified by:	Rev
C	OMAP_EVM_MAIN_BOARD_SCH	Mistral	G
Date:	Tuesday, September 15, 2009	Sheet	9 of 20

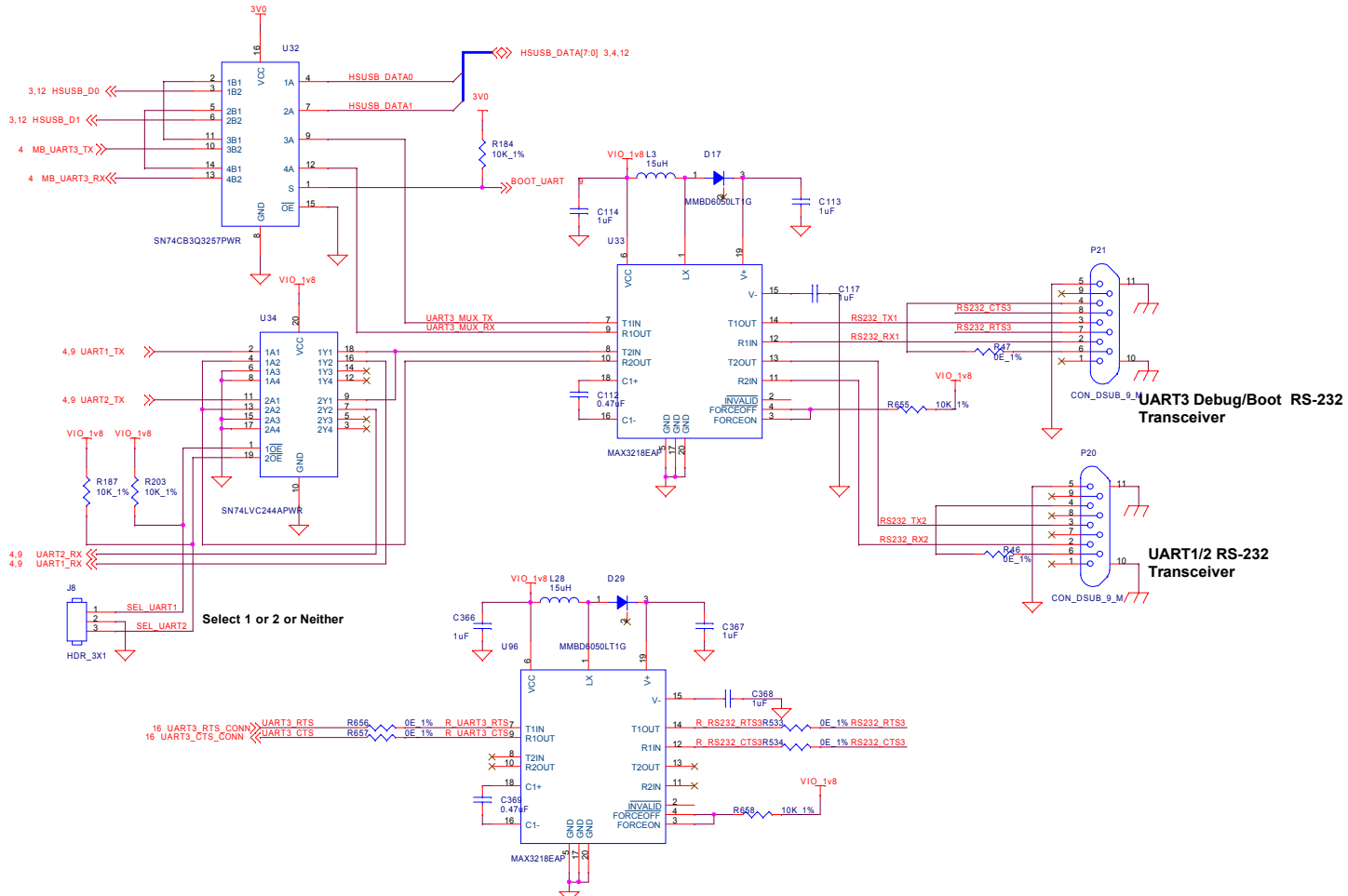

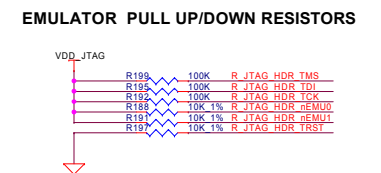
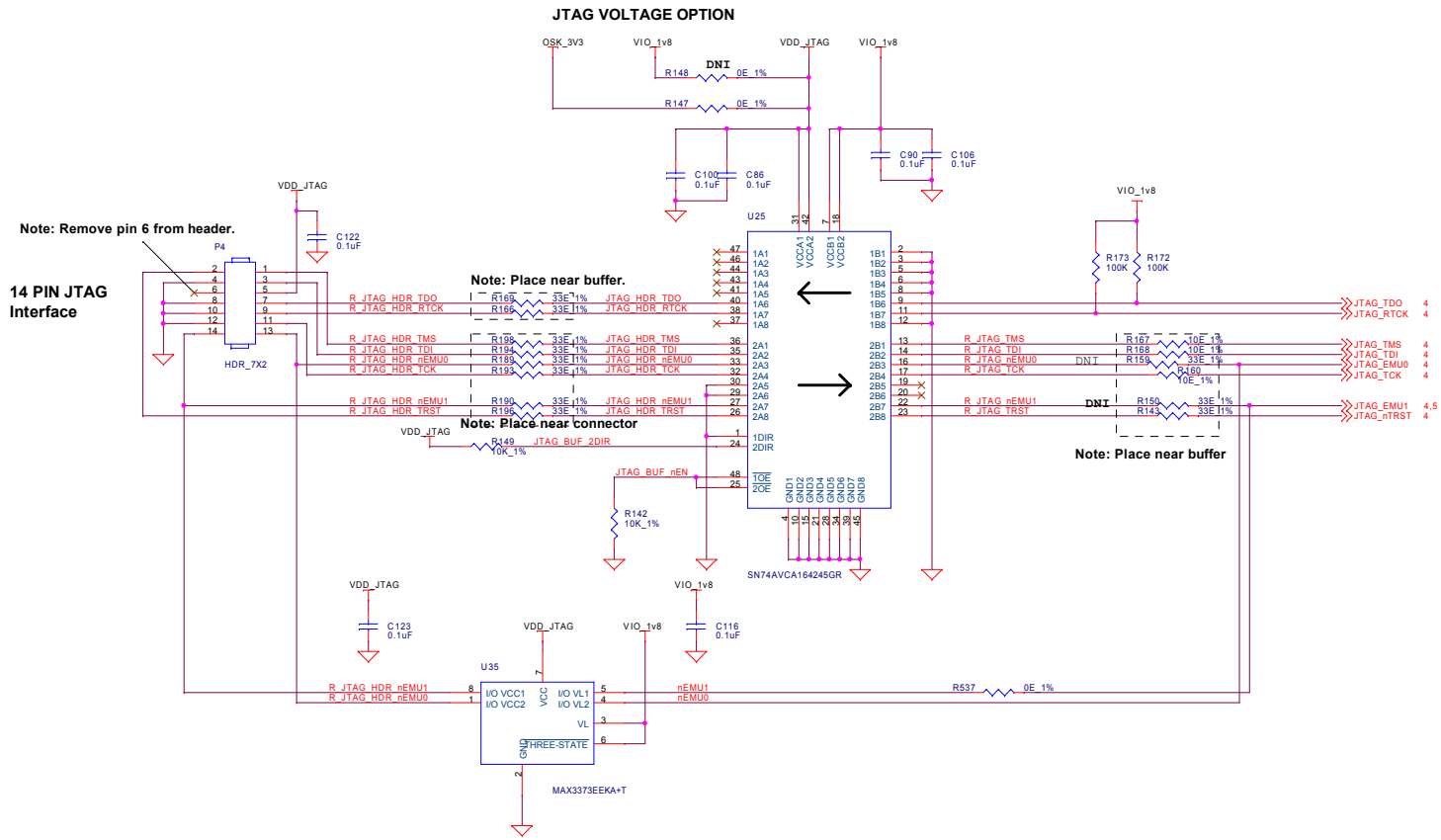

ETM Connector

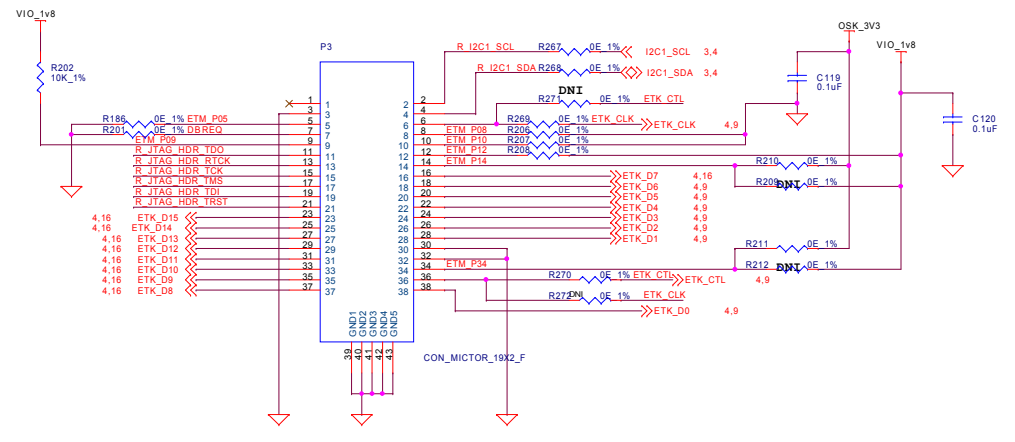

	Texas Instruments Incorporated Broadmarket OMAP Support Team <i>Under Non Disclosure Agreement</i> 12500 TI Blvd Dallas, TX 75243 <i>TI - Proprietary Information Do Not Copy</i>													
	OMAP35x EVM MAIN BOARD JTAG and ETM Debug Interfaces													
PRELIMINARY documents contain information on a product under development and is issued for evaluation purposes only. Features characteristic data and other information are subject to change.	<table border="1"> <tr> <td>Size</td> <td>Document Number</td> <td>Modified by:</td> <td>Rev</td> </tr> <tr> <td>C</td> <td>OMAP_EVM_MAIN_BOARD_SCH</td> <td>Mistral</td> <td>G</td> </tr> </table>	Size	Document Number	Modified by:	Rev	C	OMAP_EVM_MAIN_BOARD_SCH	Mistral	G	<table border="1"> <tr> <td>Date:</td> <td>Tuesday, September 15, 2009</td> <td>Sheet</td> <td>11 of 20</td> </tr> </table>	Date:	Tuesday, September 15, 2009	Sheet	11 of 20
Size	Document Number	Modified by:	Rev											
C	OMAP_EVM_MAIN_BOARD_SCH	Mistral	G											
Date:	Tuesday, September 15, 2009	Sheet	11 of 20											

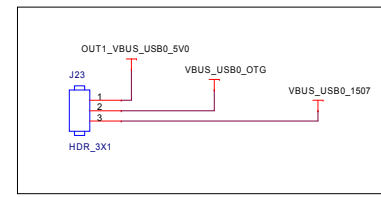
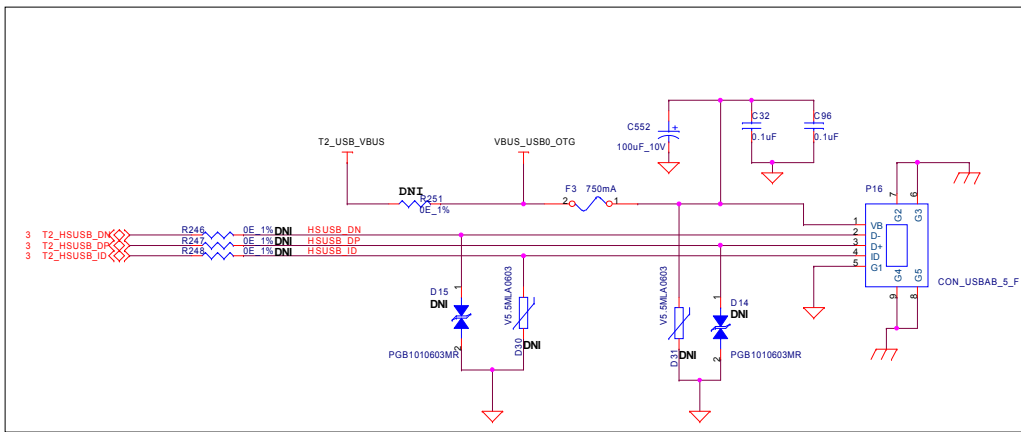
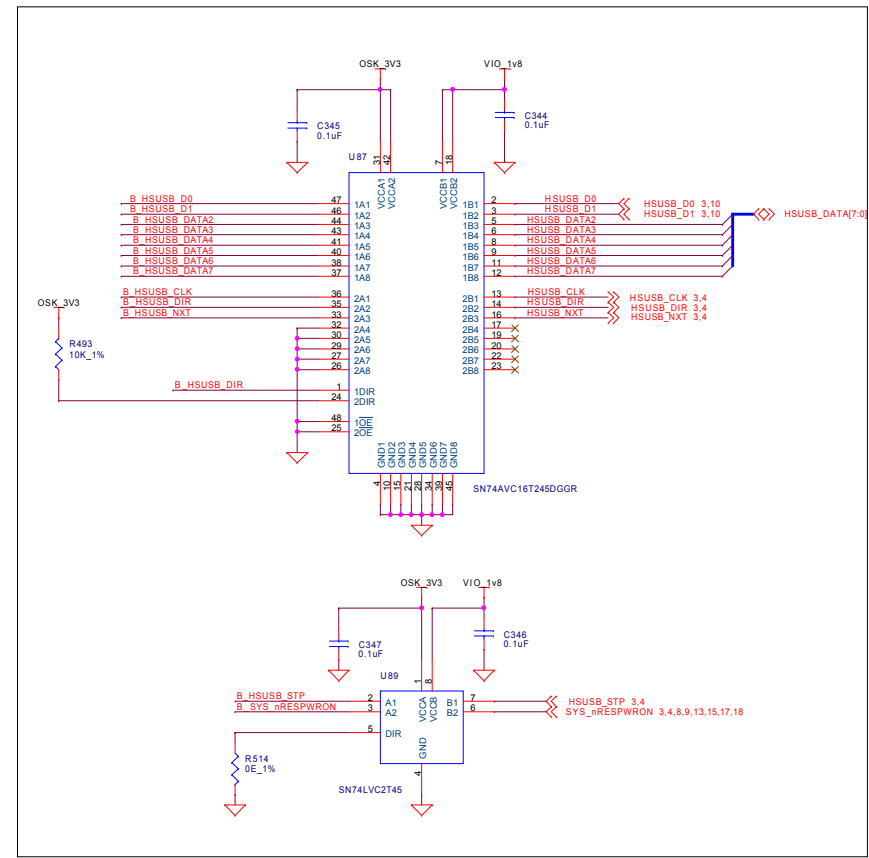
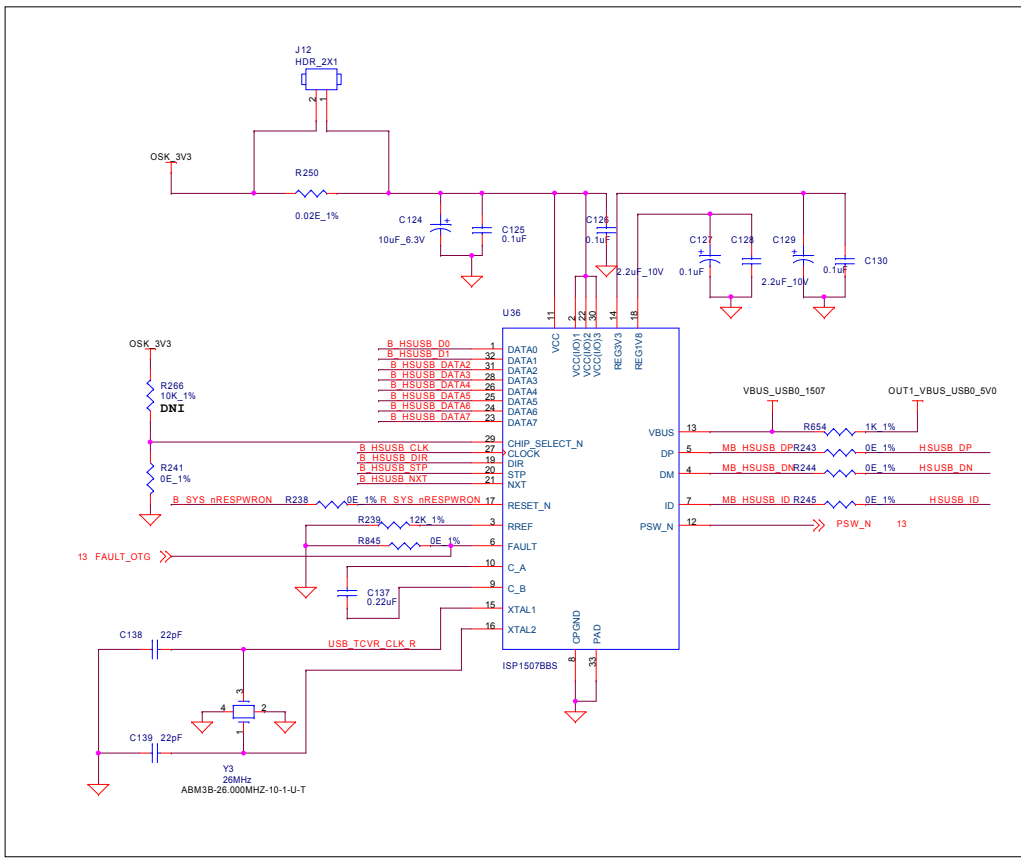

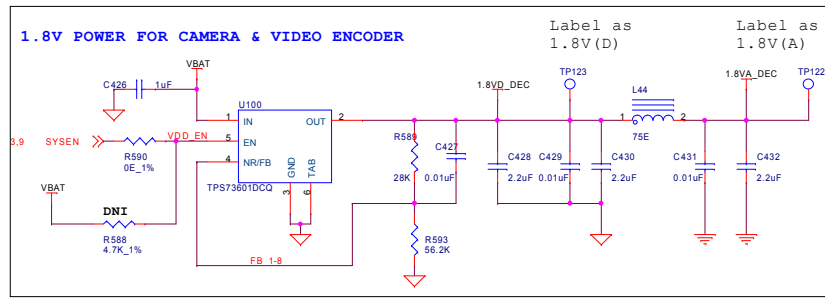
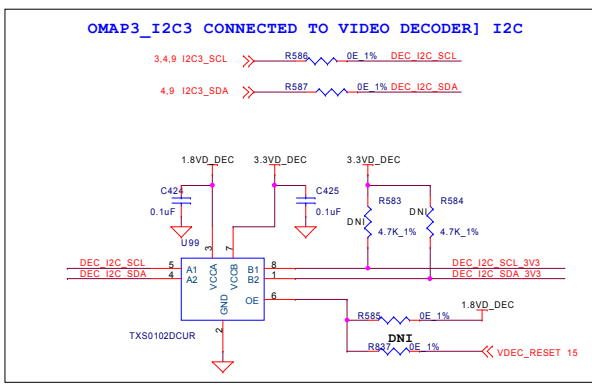
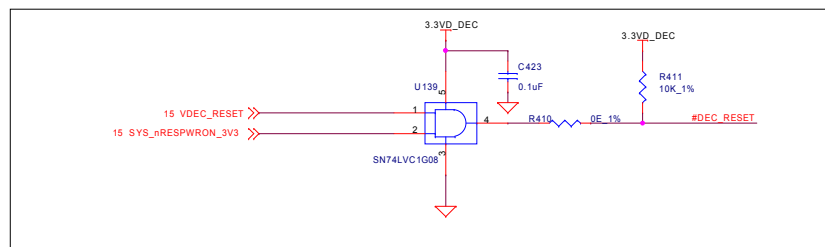
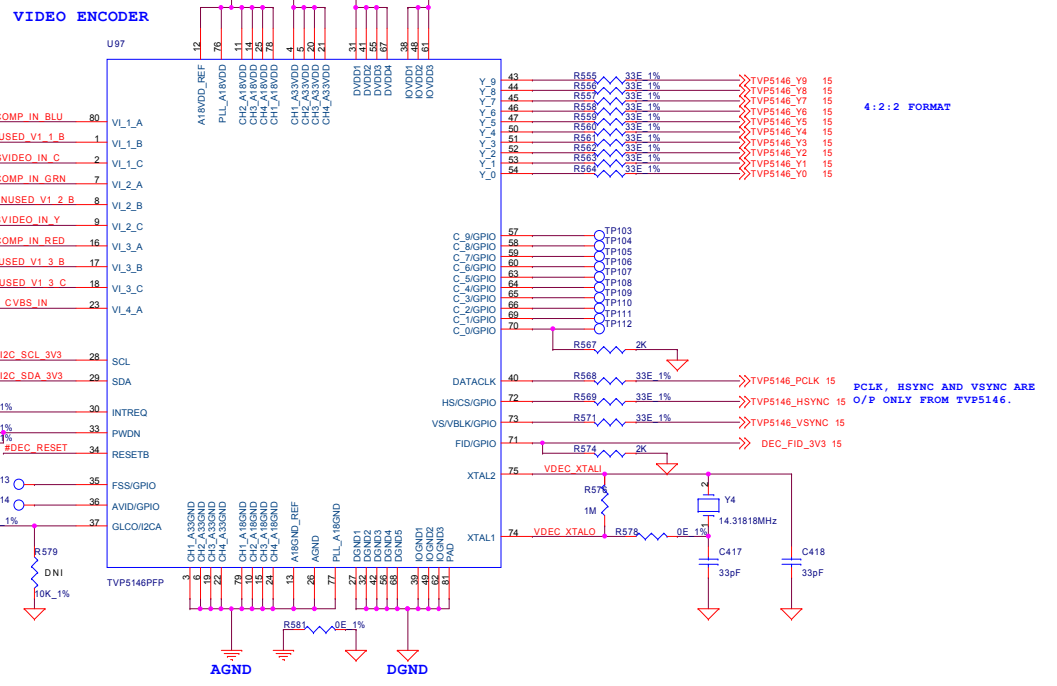
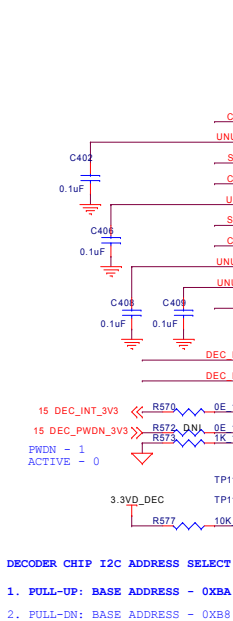
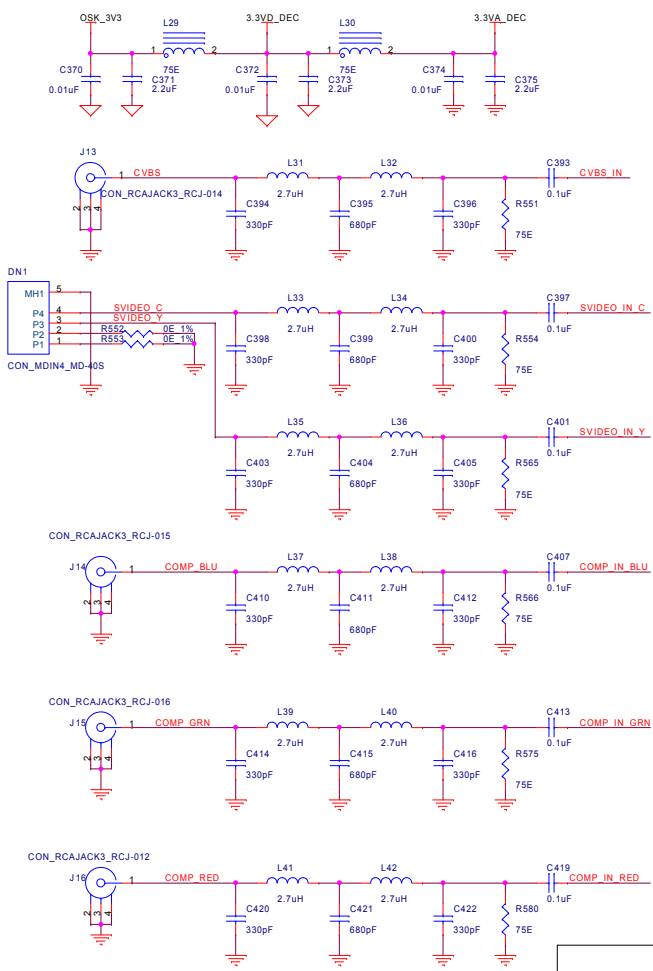

TEXAS INSTRUMENTS

Texas Instruments Incorporated
Broadmarket OMAP Support Team Under Non Disclosure Agreement
12500 TI Blvd
Dallas, TX 75243
TI - Proprietary Information Do Not Copy

OMAP35x EVM MAIN BOARD
Video_Decoder_TVP5146A

Size	Document Number	Modified by:	Rev
C	OMAP_EVM_MAIN_BOARD_SCH	Mistral	G

Date: Tuesday, September 15, 2009 Sheet 14 of 20

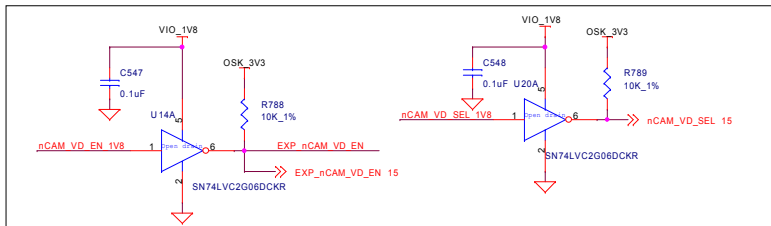
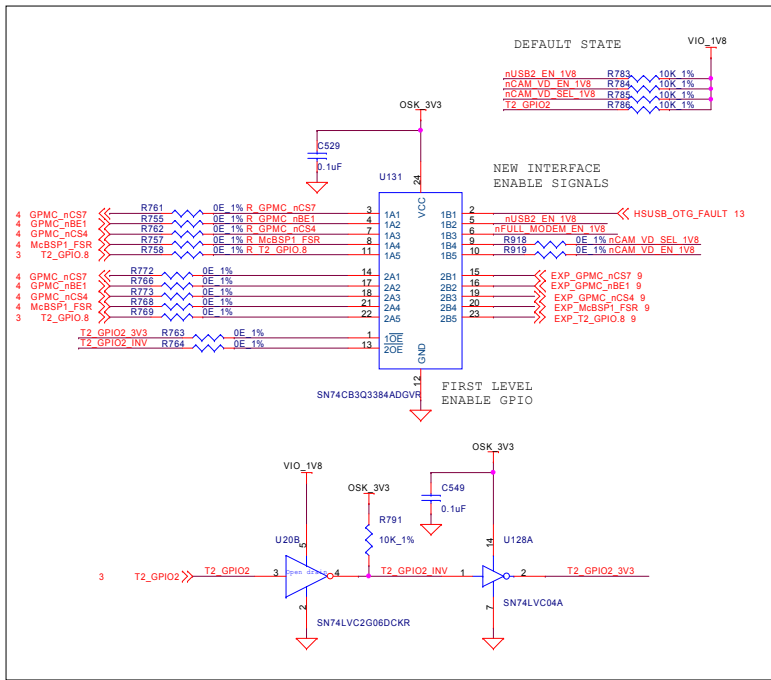

Video Input Selection Table

nCAM_VD_EN_1V8 (T2_GPIO.8)	nCAM_VD_SEL_1V8 (GPIO_157)	JP1 Shunt position	Selected Video Input option
HIGH (DEFAULT)	X	X	From Exp. Conn (Default)
LOW	HIGH	X	Video Encoder (TPV5146A)
LOW	LOW	1-2	On board LI-3MC02 Module
LOW	LOW	2-3	Micron Camera Connector

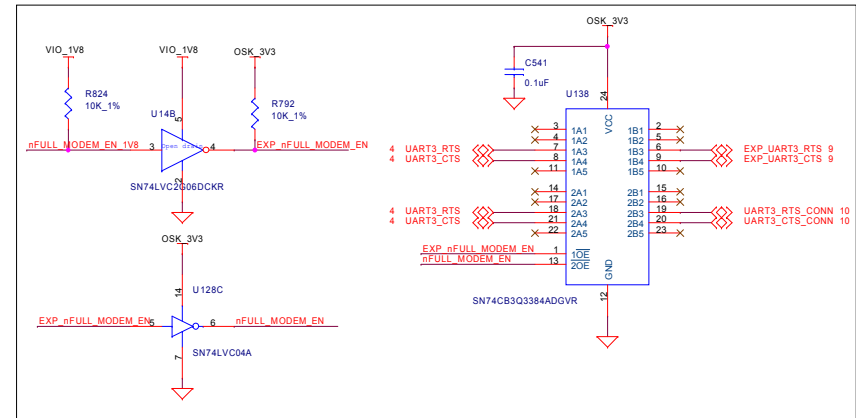
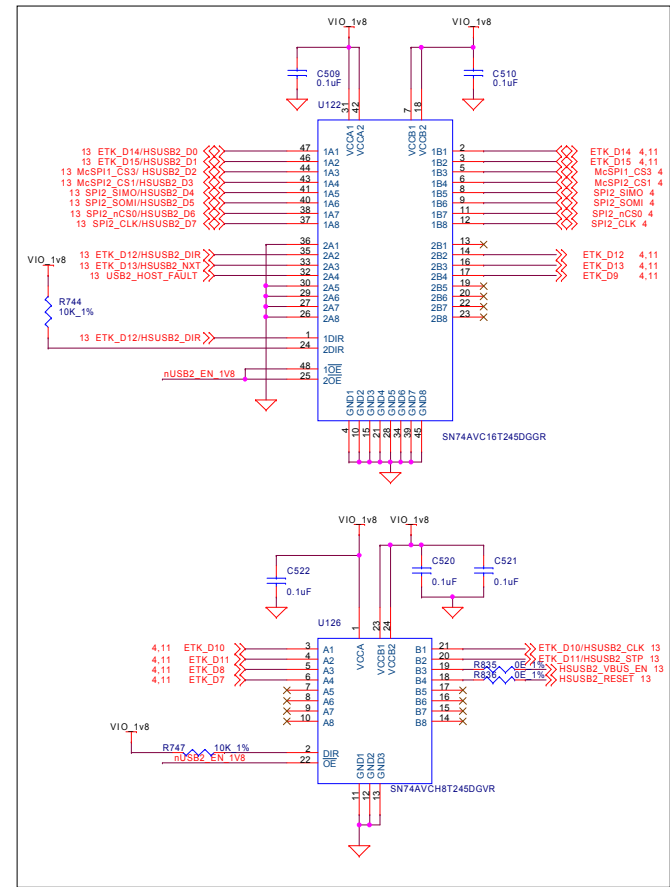
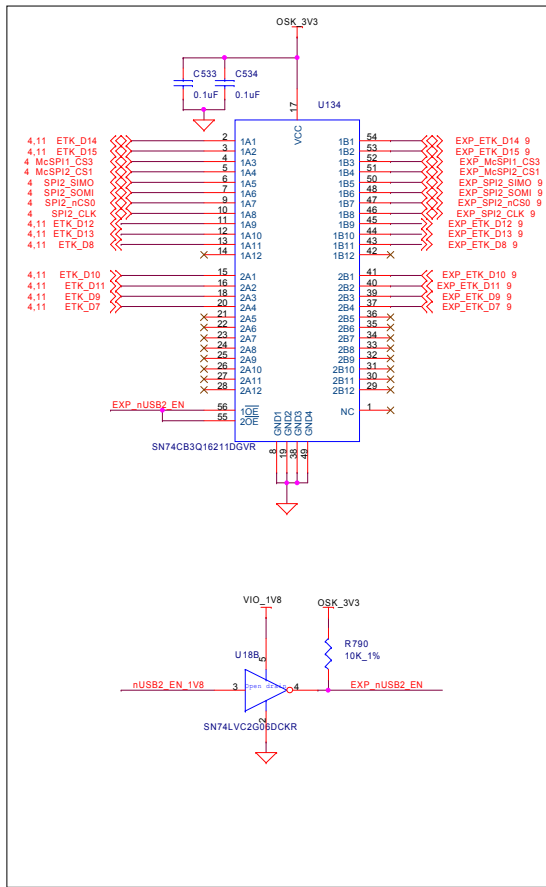
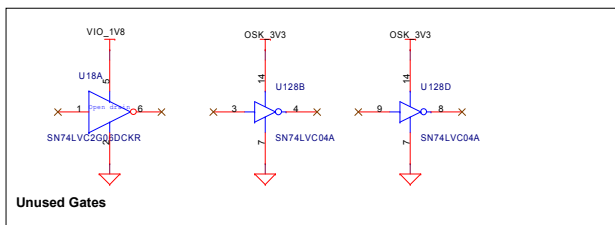

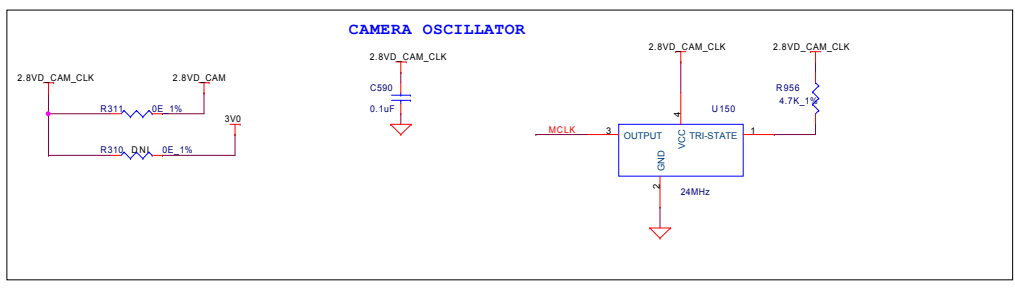
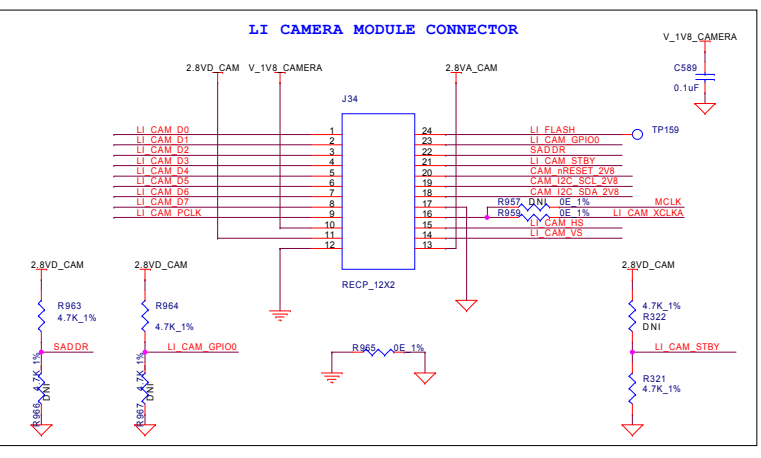
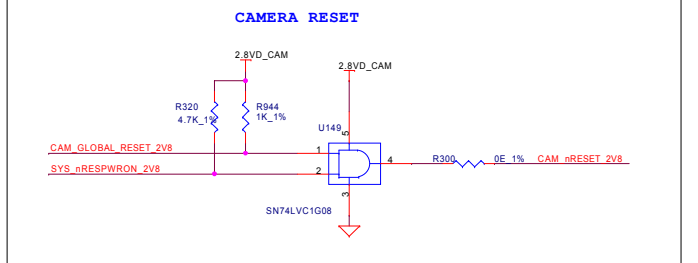
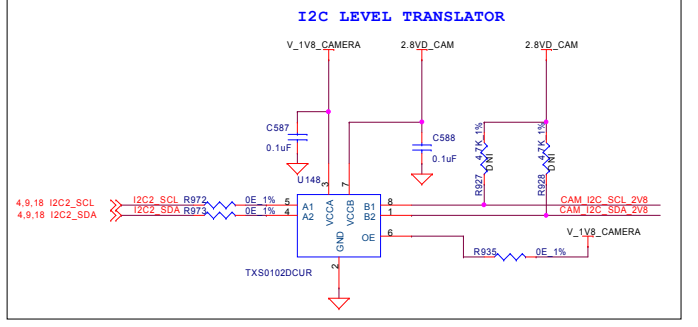
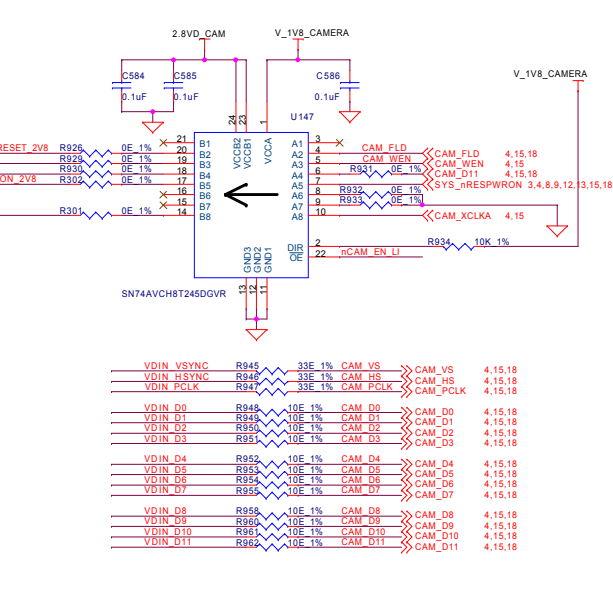
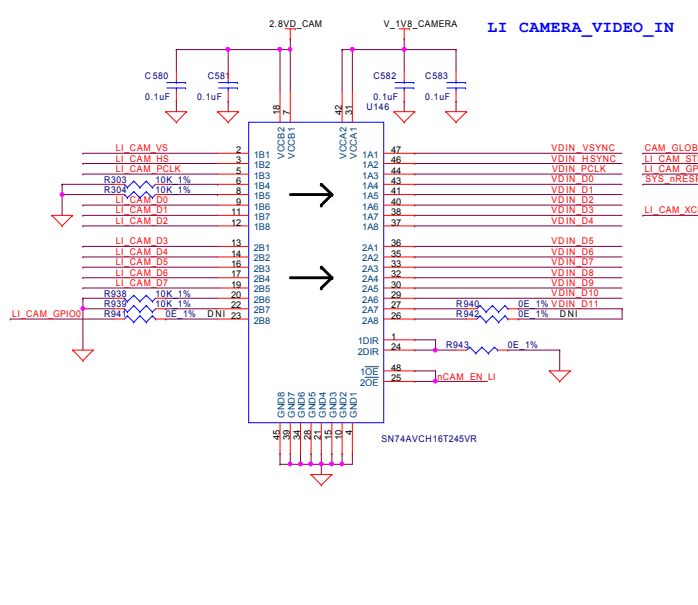
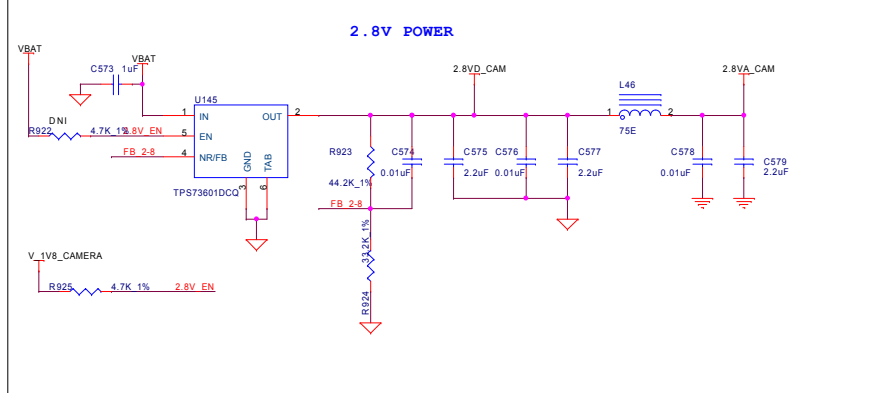
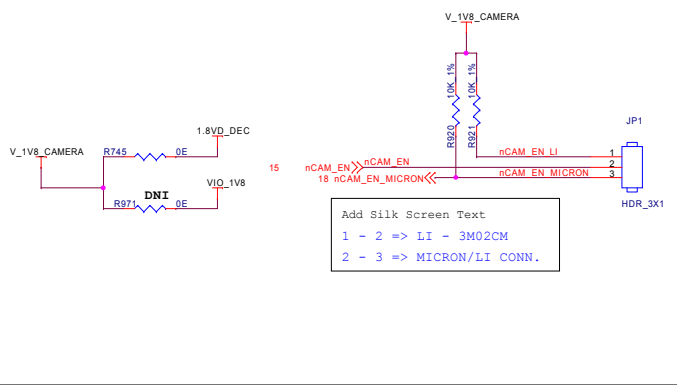

TEXAS INSTRUMENTS

Texas Instruments Incorporated
 Broadmarket OMAP Support Team Under Non Disclosure Agreement
 12500 TI Blvd
 Dallas, TX 75243
 TI - Proprietary Information Do Not Copy

PRELIMINARY documents contain information on a product under development and is issued for evaluation purposes only. Features characteristic data and other information are subject to change.

OMAP35x EVM MAIN BOARD
 On board Camera interface

Size	Document Number	Modified by:	Rev
C	OMAP_EVM_MAIN_BOARD_SCH	Mistral	G

Date: Tuesday, September 15, 2009 Sheet 17 of 20

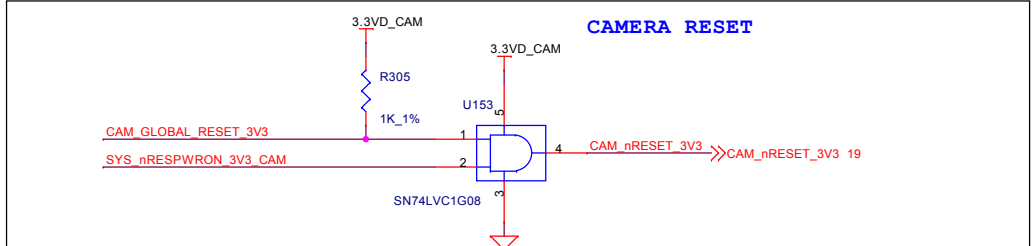
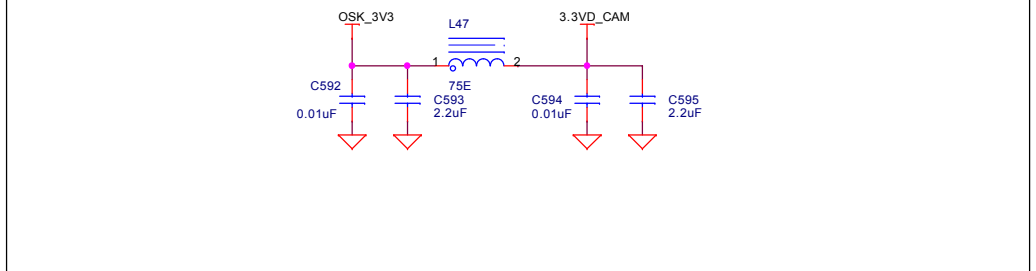
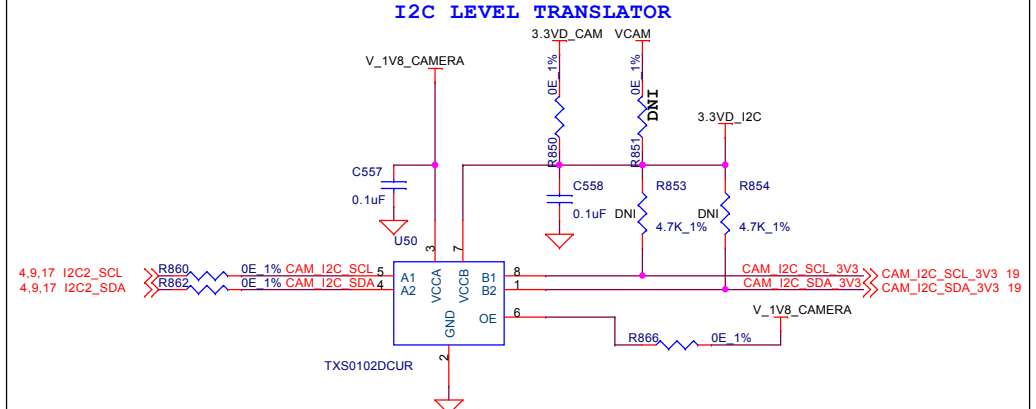
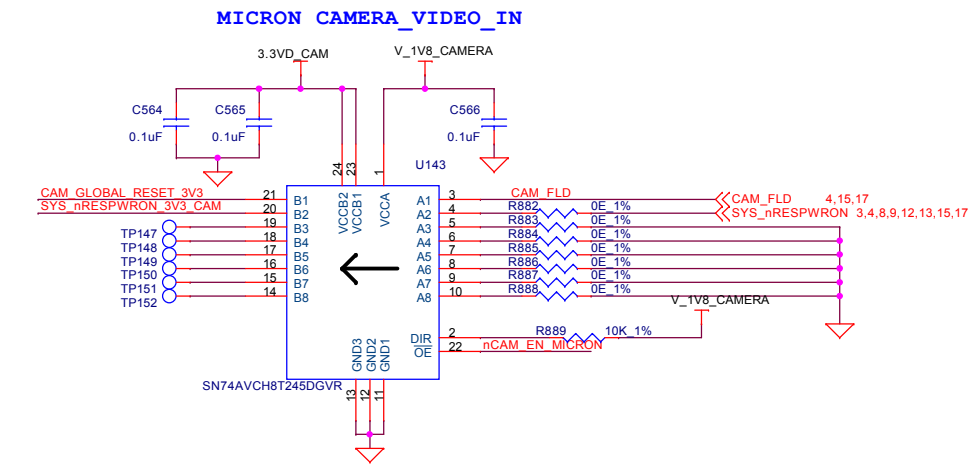
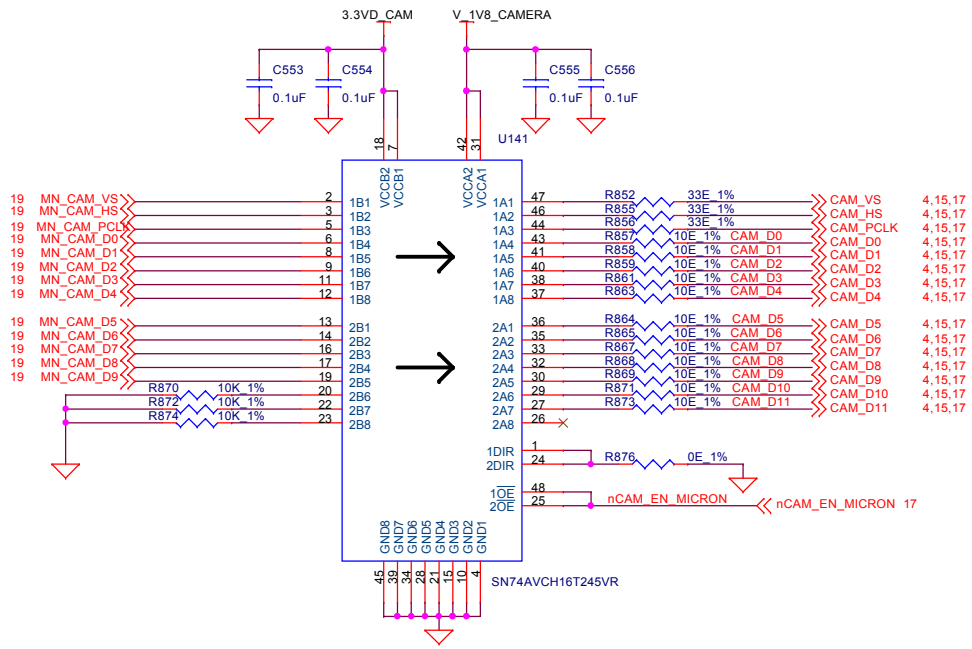

TEXAS INSTRUMENTS

PRELIMINARY documents contain information on a product under development and is issued for evaluation purposes only. Features characteristic data and other information are subject to change.

Texas Instruments Incorporated
 Broadmarket OMAP Support Team Under Non Disclosure Agreement
 12500 TI Blvd Dallas, TX 75243
 TI - Proprietary Information Do Not Copy

OMAP35x EVM MAIN BOARD
 Micron Conn. Transceivers

Size B	Document Number OMAP_EVM_MAIN_BOARD_SCH	Modified by: Mistral	Rev G
Date:	Tuesday, September 15, 2009	Sheet	18 of 20

MICRON CAMERA MODULE CONNECTOR - 1

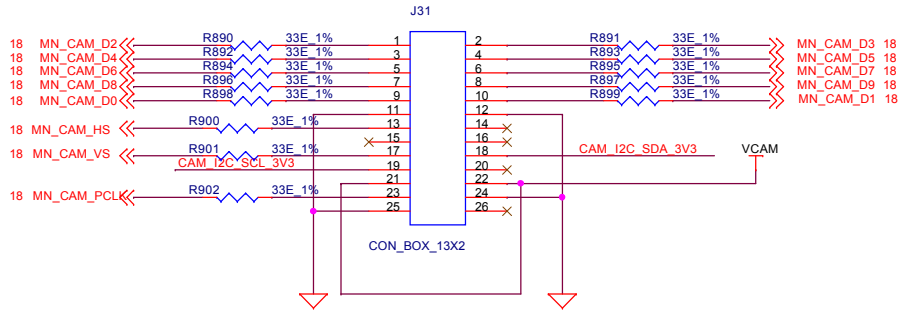

MICRON CAMERA MODULE - SUPPLY

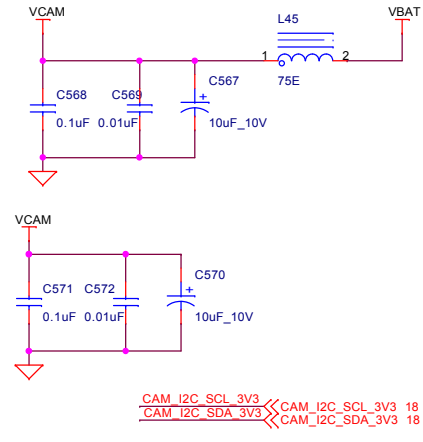

~~CAM_I2C_SCL_3V3~~ CAM_I2C_SCL_3V3 18
~~CAM_I2C_SDA_3V3~~ CAM_I2C_SDA_3V3 18

MICRON CAMERA MODULE CONNECTOR - 2 (LI CONNECTOR)

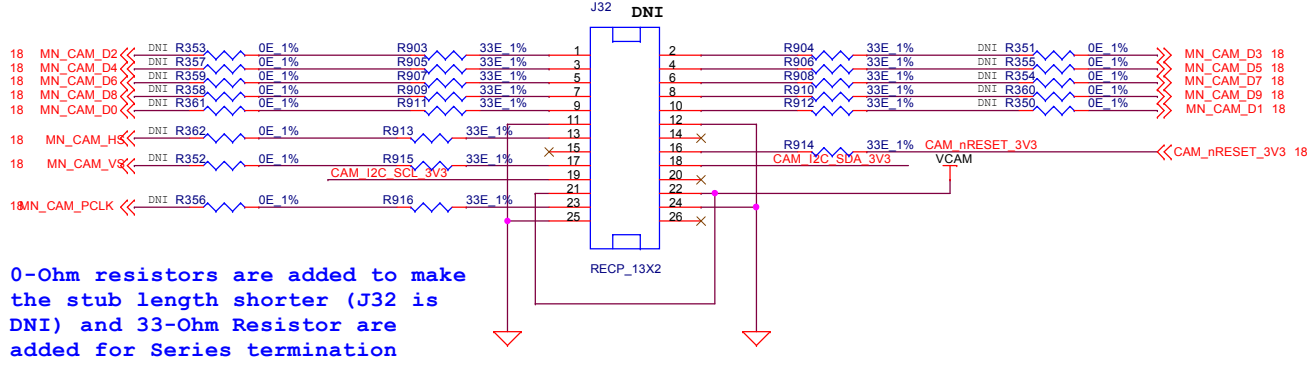

0-Ohm resistors are added to make the stub length shorter (J32 is DNI) and 33-Ohm Resistor are added for Series termination



Texas Instruments Incorporated
 Broadmarket OMAP Support Team Under Non Disclosure Agreement
 12500 TI Blvd
 Dallas, TX 75243
TI - Proprietary Information Do Not Copy

PRELIMINARY documents contain information on a product under development and is issued for evaluation purposes only. Features characteristic data and other information are subject to change.

OMAP35x EVM MAIN BOARD Micron & LI Camera Connectors			
Size B	Document Number OMAP_EVM_MAIN_BOARD_SCH	Modified by: Mistral	Rev G
Date:	Tuesday, September 15, 2009	Sheet	19 of 20

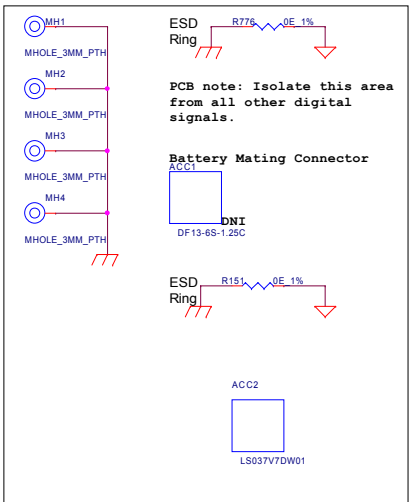

		Texas Instruments Incorporated Broadmarket OMAP Support Team <i>Under Non Disclosure Agreement</i> 12500 TI Blvd Dallas, TX 75243 <i>TI - Proprietary Information Do Not Copy</i>	
		OMAP35x EVM MAIN BOARD Miscellaneous	
Size	Document Number	Modified by:	Rev
C	OMAP_EVM_MAIN_BOARD_SCH	Mistral	G
Date: Tuesday, September 15, 2009		Sheet	20 of 20

PRELIMINARY documents contain information on a product under development and is issued for evaluation purposes only. Features characteristic data and other information are subject to change.