

TMS320C674x/OMAP-L1x Processor Enhanced High-Resolution Pulse-Width Modulator (eHRPWM)

User's Guide



Literature Number: SPRUFL3B

November 2009

Preface	9
1 Introduction	11
1.1 Introduction	11
1.2 Submodule Overview	11
1.3 Register Mapping	15
2 Architecture	16
2.1 Overview	16
2.2 Proper Interrupt Initialization Procedure	19
2.3 Time-Base (TB) Submodule	19
2.4 Counter-Compare (CC) Submodule	28
2.5 Action-Qualifier (AQ) Submodule	33
2.6 Dead-Band Generator (DB) Submodule	51
2.7 PWM-Chopper (PC) Submodule	55
2.8 Trip-Zone (TZ) Submodule	59
2.9 Event-Trigger (ET) Submodule	63
2.10 High-Resolution PWM (HRPWM) Submodule	67
3 Applications to Power Topologies	74
3.1 Overview of Multiple Modules	74
3.2 Key Configuration Capabilities	75
3.3 Controlling Multiple Buck Converters With Independent Frequencies	76
3.4 Controlling Multiple Buck Converters With Same Frequencies	79
3.5 Controlling Multiple Half H-Bridge (HHB) Converters	82
3.6 Controlling Dual 3-Phase Inverters for Motors (ACI and PMSM)	85
3.7 Practical Applications Using Phase Control Between PWM Modules	89
3.8 Controlling a 3-Phase Interleaved DC/DC Converter	90
3.9 Controlling Zero Voltage Switched Full Bridge (ZVSFB) Converter	95
4 Registers	98
4.1 Time-Base Submodule Registers	98
4.2 Counter-Compare Submodule Registers	102
4.3 Action-Qualifier Submodule Registers	105
4.4 Dead-Band Generator Submodule Registers	109
4.5 PWM-Chopper Submodule Register	112
4.6 Trip-Zone Submodule Registers	113
4.7 Event-Trigger Submodule Registers	117
4.8 High-Resolution PWM Submodule Registers	120
Appendix A Revision History	123

List of Figures

1	Multiple ePWM Modules	12
2	Submodules and Signal Connections for an ePWM Module	13
3	ePWM Submodules and Critical Internal Signal Interconnects.....	14
4	Time-Base Submodule Block Diagram	19
5	Time-Base Submodule Signals and Registers	20
6	Time-Base Frequency and Period	22
7	Time-Base Counter Synchronization Scheme 1	23
8	Time-Base Up-Count Mode Waveforms.....	25
9	Time-Base Down-Count Mode Waveforms	26
10	Time-Base Up-Down-Count Waveforms, TBCTL[PHSDIR = 0] Count Down on Synchronization Event.....	26
11	Time-Base Up-Down Count Waveforms, TBCTL[PHSDIR = 1] Count Up on Synchronization Event	27
12	Counter-Compare Submodule	28
13	Counter-Compare Submodule Signals and Registers.....	28
14	Counter-Compare Event Waveforms in Up-Count Mode	31
15	Counter-Compare Events in Down-Count Mode	31
16	Counter-Compare Events in Up-Down-Count Mode, TBCTL[PHSDIR = 0] Count Down on Synchronization Event	32
17	Counter-Compare Events in Up-Down-Count Mode, TBCTL[PHSDIR = 1] Count Up on Synchronization Event	32
18	Action-Qualifier Submodule	33
19	Action-Qualifier Submodule Inputs and Outputs	34
20	Possible Action-Qualifier Actions for EPWMxA and EPWMxB Outputs.....	35
21	Up-Down-Count Mode Symmetrical Waveform	38
22	Up, Single Edge Asymmetric Waveform, With Independent Modulation on EPWMxA and EPWMxB—Active High	39
23	Up, Single Edge Asymmetric Waveform With Independent Modulation on EPWMxA and EPWMxB—Active Low.....	41
24	Up-Count, Pulse Placement Asymmetric Waveform With Independent Modulation on EPWMxA	43
25	Up-Down-Count, Dual Edge Symmetric Waveform, With Independent Modulation on EPWMxA and EPWMxB — Active Low	45
26	Up-Down-Count, Dual Edge Symmetric Waveform, With Independent Modulation on EPWMxA and EPWMxB — Complementary	47
27	Up-Down-Count, Dual Edge Asymmetric Waveform, With Independent Modulation on EPWMxA—Active Low	49
28	Dead-Band Generator Submodule	51
29	Configuration Options for the Dead-Band Generator Submodule	52
30	Dead-Band Waveforms for Typical Cases (0% < Duty < 100%).....	54
31	PWM-Chopper Submodule.....	55
32	PWM-Chopper Submodule Signals and Registers	56
33	Simple PWM-Chopper Submodule Waveforms Showing Chopping Action Only	57
34	PWM-Chopper Submodule Waveforms Showing the First Pulse and Subsequent Sustaining Pulses	57
35	PWM-Chopper Submodule Waveforms Showing the Pulse Width (Duty Cycle) Control of Sustaining Pulses.....	58
36	Trip-Zone Submodule.....	59
37	Trip-Zone Submodule Mode Control Logic	62
38	Trip-Zone Submodule Interrupt Logic.....	62
39	Event-Trigger Submodule	63
40	Event-Trigger Submodule Inter-Connectivity to Interrupt Controller	64
41	Event-Trigger Submodule Showing Event Inputs and Prescaled Outputs.....	64

42	Event-Trigger Interrupt Generator	66
43	HRPWM System Interface	67
44	Resolution Calculations for Conventionally Generated PWM	68
45	Operating Logic Using MEP	69
46	Required PWM Waveform for a Requested Duty = 40.5%	71
47	Low % Duty Cycle Range Limitation Example When PWM Frequency = 1 MHz.....	73
48	High % Duty Cycle Range Limitation Example when PWM Frequency = 1 MHz.....	73
49	Simplified ePWM Module.....	74
50	EPWM1 Configured as a Typical Master, EPWM2 Configured as a Slave	75
51	Control of Four Buck Stages. Here $F_{P_{PWM1}} \neq F_{P_{PWM2}} \neq F_{P_{PWM3}} \neq F_{P_{PWM4}}$	76
52	Buck Waveforms for (Note: Only three bucks shown here).....	77
53	Control of Four Buck Stages. (Note: $F_{P_{PWM2}} = N \times F_{P_{PWM1}}$).....	79
54	Buck Waveforms for (Note: $F_{P_{PWM2}} = F_{P_{PWM1}}$).....	80
55	Control of Two Half-H Bridge Stages ($F_{P_{PWM2}} = N \times F_{P_{PWM1}}$).....	82
56	Half-H Bridge Waveforms for (Note: Here $F_{P_{PWM2}} = F_{P_{PWM1}}$)	83
57	Control of Dual 3-Phase Inverter Stages as Is Commonly Used in Motor Control	85
58	3-Phase Inverter Waveforms for (Only One Inverter Shown)	86
59	Configuring Two PWM Modules for Phase Control	89
60	Timing Waveforms Associated With Phase Control Between 2 Modules.....	90
61	Control of a 3-Phase Interleaved DC/DC Converter	91
62	3-Phase Interleaved DC/DC Converter Waveforms for	92
63	Controlling a Full-H Bridge Stage ($F_{P_{PWM2}} = F_{P_{PWM1}}$)	95
64	ZVS Full-H Bridge Waveforms.....	96
65	Time-Base Control Register (TBCTL)	98
66	Time-Base Status Register (TBSTS).....	100
67	Time-Base Phase Register (TBPHS).....	101
68	Time-Base Counter Register (TBCNT).....	101
69	Time-Base Period Register (TBPRD)	102
70	Counter-Compare Control Register (CMPCTL).....	103
71	Counter-Compare A Register (CMPA)	104
72	Counter-Compare B Register (CMPB)	105
73	Action-Qualifier Output A Control Register (AQCTLA).....	106
74	Action-Qualifier Output B Control Register (AQCTLB).....	107
75	Action-Qualifier Software Force Register (AQSFRC)	108
76	Action-Qualifier Continuous Software Force Register (AQCSFRC).....	109
77	Dead-Band Generator Control Register (DBCTL)	110
78	Dead-Band Generator Rising Edge Delay Register (DBRED).....	111
79	Dead-Band Generator Falling Edge Delay Register (DBFED).....	111
80	PWM-Chopper Control Register (PCCTL).....	112
81	Trip-Zone Select Register (TZSEL).....	113
82	Trip-Zone Control Register (TZCTL)	114
83	Trip-Zone Enable Interrupt Register (TZEINT).....	114
84	Trip-Zone Flag Register (TZFLG).....	115
85	Trip-Zone Clear Register (TZCLR)	116
86	Trip-Zone Force Register (TZFRC).....	116
87	Event-Trigger Selection Register (ETSEL)	117
88	Event-Trigger Prescale Register (ETPS)	118
89	Event-Trigger Flag Register (ETFLG).....	119
90	Event-Trigger Clear Register (ETCLR).....	119

91	Event-Trigger Force Register (ETFRC)	120
92	Time-Base Phase High-Resolution Register (TBPHSHR).....	121
93	Counter-Compare A High-Resolution Register (CMPAHR)	121
94	HRPWM Configuration Register (HRCNFG)	122

List of Tables

1	ePWM Module Control and Status Registers Grouped by Submodule	15
2	Submodule Configuration Parameters	16
3	Time-Base Submodule Registers	20
4	Key Time-Base Signals	21
5	Counter-Compare Submodule Registers	29
6	Counter-Compare Submodule Key Signals	29
7	Action-Qualifier Submodule Registers	33
8	Action-Qualifier Submodule Possible Input Events	34
9	Action-Qualifier Event Priority for Up-Down-Count Mode	36
10	Action-Qualifier Event Priority for Up-Count Mode	36
11	Action-Qualifier Event Priority for Down-Count Mode	36
12	Behavior if CMPA/CMPB is Greater than the Period	37
13	EPWMx Initialization for	40
14	EPWMx Run Time Changes for	40
15	EPWMx Initialization for	42
16	EPWMx Run Time Changes for	42
17	EPWMx Initialization for	44
18	EPWMx Run Time Changes for	44
19	EPWMx Initialization for	46
20	EPWMx Run Time Changes for	46
21	EPWMx Initialization for	48
22	EPWMx Run Time Changes for	48
23	EPWMx Initialization for	50
24	EPWMx Run Time Changes for	50
25	Dead-Band Generator Submodule Registers	51
26	Classical Dead-Band Operating Modes	53
27	PWM-Chopper Submodule Registers	55
28	Trip-Zone Submodule Registers	60
29	Possible Actions On a Trip Event	61
30	Event-Trigger Submodule Registers	63
31	Resolution for PWM and HRPWM	68
32	HRPWM Submodule Registers	69
33	Relationship Between MEP Steps, PWM Frequency and Resolution	70
34	CMPA vs Duty (left), and [CMPA:CMPAHR] vs Duty (right)	71
35	EPWM1 Initialization for	78
36	EPWM2 Initialization for	78
37	EPWM3 Initialization for	78
38	EPWM1 Initialization for	81
39	EPWM2 Initialization for	81
40	EPWM1 Initialization for	84
41	EPWM2 Initialization for	84
42	EPWM1 Initialization for	87
43	EPWM2 Initialization for	87
44	EPWM3 Initialization for	88
45	EPWM1 Initialization for	93
46	EPWM2 Initialization for	93
47	EPWM3 Initialization for	94

48	EPWM1 Initialization for	97
49	EPWM2 Initialization for	97
50	Submodule Registers	98
51	Time-Base Submodule Registers	98
52	Time-Base Control Register (TBCTL) Field Descriptions	99
53	Time-Base Status Register (TBSTS) Field Descriptions	100
54	Time-Base Phase Register (TBPHS) Field Descriptions	101
55	Time-Base Counter Register (TBCNT) Field Descriptions	101
56	Time-Base Period Register (TBPRD) Field Descriptions	102
57	Counter-Compare Submodule Registers	102
58	Counter-Compare Control Register (CMPCTL) Field Descriptions	103
59	Counter-Compare A Register (CMPA) Field Descriptions	104
60	Counter-Compare B Register (CMPB) Field Descriptions	105
61	Action-Qualifier Submodule Registers	105
62	Action-Qualifier Output A Control Register (AQCTLA) Field Descriptions	106
63	Action-Qualifier Output B Control Register (AQCTLB) Field Descriptions	107
64	Action-Qualifier Software Force Register (AQSFRC) Field Descriptions	108
65	Action-Qualifier Continuous Software Force Register (AQCSFRC) Field Descriptions	109
66	Dead-Band Generator Submodule Registers	109
67	Dead-Band Generator Control Register (DBCTL) Field Descriptions	110
68	Dead-Band Generator Rising Edge Delay Register (DBRED) Field Descriptions	111
69	Dead-Band Generator Falling Edge Delay Register (DBFED) Field Descriptions	111
70	PWM-Chopper Control Register (PCCTL) Bit Descriptions	112
71	Trip-Zone Submodule Registers	113
72	Trip-Zone Submodule Select Register (TZSEL) Field Descriptions	113
73	Trip-Zone Control Register (TZCTL) Field Descriptions	114
74	Trip-Zone Enable Interrupt Register (TZEINT) Field Descriptions	114
75	Trip-Zone Flag Register (TZFLG) Field Descriptions	115
76	Trip-Zone Clear Register (TZCLR) Field Descriptions	116
77	Trip-Zone Force Register (TZFRC) Field Descriptions	116
78	Event-Trigger Submodule Registers	117
79	Event-Trigger Selection Register (ETSEL) Field Descriptions	117
80	Event-Trigger Prescale Register (ETPS) Field Descriptions	118
81	Event-Trigger Flag Register (ETFLG) Field Descriptions	119
82	Event-Trigger Clear Register (ETCLR) Field Descriptions	119
83	Event-Trigger Force Register (ETFRC) Field Descriptions	120
84	High-Resolution PWM Submodule Registers	120
85	Time-Base Phase High-Resolution Register (TBPHSHR) Field Descriptions	121
86	Counter-Compare A High-Resolution Register (CMPAHR) Field Descriptions	121
87	HRPWM Configuration Register (HRCNFG) Field Descriptions	122
88	Document Revision History	123

Read This First

About This Manual

This document describes the enhanced high-resolution pulse-width modulator (eHRPWM). The eHRPWM extends the time resolution capabilities of the conventionally derived digital pulse width modulator (PWM).

Notational Conventions

This document uses the following conventions.

- Hexadecimal numbers are shown with the suffix h. For example, the following number is 40 hexadecimal (decimal 64): 40h.
- Registers in this document are shown in figures and described in tables.
 - Each register figure shows a rectangle divided into fields that represent the fields of the register. Each field is labeled with its bit name, its beginning and ending bit numbers above, and its read/write properties below. A legend explains the notation used for the properties.
 - Reserved bits in a register figure designate a bit that is used for future device expansion.

Related Documentation From Texas Instruments

The following documents describe the TMS320C674x Digital Signal Processors (DSPs) and OMAP-L1x Applications Processors. Copies of these documents are available on the Internet at www.ti.com. *Tip:* Enter the literature number in the search box provided at www.ti.com.

The current documentation that describes the DSP, related peripherals, and other technical collateral, is available in the C6000 DSP product folder at: www.ti.com/c6000.

[SPRUGM5](#) — ***TMS320C6742 DSP System Reference Guide***. Describes the C6742 DSP subsystem, system memory, device clocking, phase-locked loop controller (PLL), power and sleep controller (PSC), power management, and system configuration module.

[SPRUGJ0](#) — ***TMS320C6743 DSP System Reference Guide***. Describes the System-on-Chip (SoC) including the C6743 DSP subsystem, system memory, device clocking, phase-locked loop controller (PLL), power and sleep controller (PSC), power management, and system configuration module.

[SPRUFK4](#) — ***TMS320C6745/C6747 DSP System Reference Guide***. Describes the System-on-Chip (SoC) including the C6745/C6747 DSP subsystem, system memory, device clocking, phase-locked loop controller (PLL), power and sleep controller (PSC), power management, and system configuration module.

[SPRUGM6](#) — ***TMS320C6746 DSP System Reference Guide***. Describes the C6746 DSP subsystem, system memory, device clocking, phase-locked loop controller (PLL), power and sleep controller (PSC), power management, and system configuration module.

[SPRUGJ7](#) — ***TMS320C6748 DSP System Reference Guide***. Describes the C6748 DSP subsystem, system memory, device clocking, phase-locked loop controller (PLL), power and sleep controller (PSC), power management, and system configuration module.

[SPRUG84](#) — ***OMAP-L137 Applications Processor System Reference Guide***. Describes the System-on-Chip (SoC) including the ARM subsystem, DSP subsystem, system memory, device clocking, phase-locked loop controller (PLL), power and sleep controller (PSC), power management, ARM interrupt controller (AINTC), and system configuration module.

- [SPRUGM7](#)** — ***OMAP-L138 Applications Processor System Reference Guide***. Describes the System-on-Chip (SoC) including the ARM subsystem, DSP subsystem, system memory, device clocking, phase-locked loop controller (PLL), power and sleep controller (PSC), power management, ARM interrupt controller (AINTC), and system configuration module.
- [SPRUFK9](#)** — ***TMS320C674x/OMAP-L1x Processor Peripherals Overview Reference Guide***. Provides an overview and briefly describes the peripherals available on the TMS320C674x Digital Signal Processors (DSPs) and OMAP-L1x Applications Processors.
- [SPRUFK5](#)** — ***TMS320C674x DSP Megamodule Reference Guide***. Describes the TMS320C674x digital signal processor (DSP) megamodule. Included is a discussion on the internal direct memory access (IDMA) controller, the interrupt controller, the power-down controller, memory protection, bandwidth management, and the memory and cache.
- [SPRUF8](#)** — ***TMS320C674x DSP CPU and Instruction Set Reference Guide***. Describes the CPU architecture, pipeline, instruction set, and interrupts for the TMS320C674x digital signal processors (DSPs). The C674x DSP is an enhancement of the C64x+ and C67x+ DSPs with added functionality and an expanded instruction set.
- [SPRUG82](#)** — ***TMS320C674x DSP Cache User's Guide***. Explains the fundamentals of memory caches and describes how the two-level cache-based internal memory architecture in the TMS320C674x digital signal processor (DSP) can be efficiently used in DSP applications. Shows how to maintain coherence with external memory, how to use DMA to reduce memory latencies, and how to optimize your code to improve cache efficiency. The internal memory architecture in the C674x DSP is organized in a two-level hierarchy consisting of a dedicated program cache (L1P) and a dedicated data cache (L1D) on the first level. Accesses by the CPU to these first level caches can complete without CPU pipeline stalls. If the data requested by the CPU is not contained in cache, it is fetched from the next lower memory level, L2 or external memory.

Enhanced High-Resolution Pulse-Width Modulator (eHRPWM)

1 Introduction

1.1 Introduction

An effective PWM peripheral must be able to generate complex pulse width waveforms with minimal CPU overhead or intervention. It needs to be highly programmable and very flexible while being easy to understand and use. The ePWM unit described here addresses these requirements by allocating all needed timing and control resources on a per PWM channel basis. Cross coupling or sharing of resources has been avoided; instead, the ePWM is built up from smaller single channel modules with separate resources and that can operate together as required to form a system. This modular approach results in an orthogonal architecture and provides a more transparent view of the peripheral structure, helping users to understand its operation quickly.

In this document the letter x within a signal or module name is used to indicate a generic ePWM instance on a device. For example output signals EPWMxA and EPWMxB refer to the output signals from the ePWMx instance. Thus, EPWM1A and EPWM1B belong to ePWM1 and likewise EPWM4A and EPWM4B belong to ePWM4.

1.2 Submodule Overview

The ePWM module represents one complete PWM channel composed of two PWM outputs: EPWMxA and EPWMxB. Multiple ePWM modules are instanced within a device as shown in [Figure 1](#). Each ePWM instance is identical with one exception. Some instances include a hardware extension that allows more precise control of the PWM outputs. This extension is the high-resolution pulse width modulator (HRPWM) and is described in [Section 2.10](#). See your device-specific data manual to determine which ePWM instances include this feature. Each ePWM module is indicated by a numerical value starting with 1. For example ePWM1 is the first instance and ePWM3 is the 3rd instance in the system and ePWMx indicates any instance.

The ePWM modules are chained together via a clock synchronization scheme that allows them to operate as a single system when required. Additionally, this synchronization scheme can be extended to the capture peripheral modules (eCAP). The number of modules is device-dependent and based on target application needs. Modules can also operate stand-alone.

Each ePWM module supports the following features:

- Dedicated 16-bit time-base counter with period and frequency control
- Two PWM outputs (EPWMxA and EPWMxB) that can be used in the following configurations::
 - Two independent PWM outputs with single-edge operation
 - Two independent PWM outputs with dual-edge symmetric operation
 - One independent PWM output with dual-edge asymmetric operation
- Asynchronous override control of PWM signals through software.
- Programmable phase-control support for lag or lead operation relative to other ePWM modules.
- Hardware-locked (synchronized) phase relationship on a cycle-by-cycle basis.
- Dead-band generation with independent rising and falling edge delay control.
- Programmable trip zone allocation of both cycle-by-cycle trip and one-shot trip on fault conditions.
- A trip condition can force either high, low, or high-impedance state logic levels at PWM outputs.

- Programmable event prescaling minimizes CPU overhead on interrupts.
- PWM chopping by high-frequency carrier signal, useful for pulse transformer gate drives.

Each ePWM module is connected to the input/output signals shown in Figure 1. The signals are described in detail in subsequent sections.

The order in which the ePWM modules are connected may differ from what is shown in Figure 1. See Section 2.3.3.2 for the synchronization scheme for a particular device. Each ePWM module consists of seven submodules and is connected within a system via the signals shown in Figure 2.

Figure 1. Multiple ePWM Modules

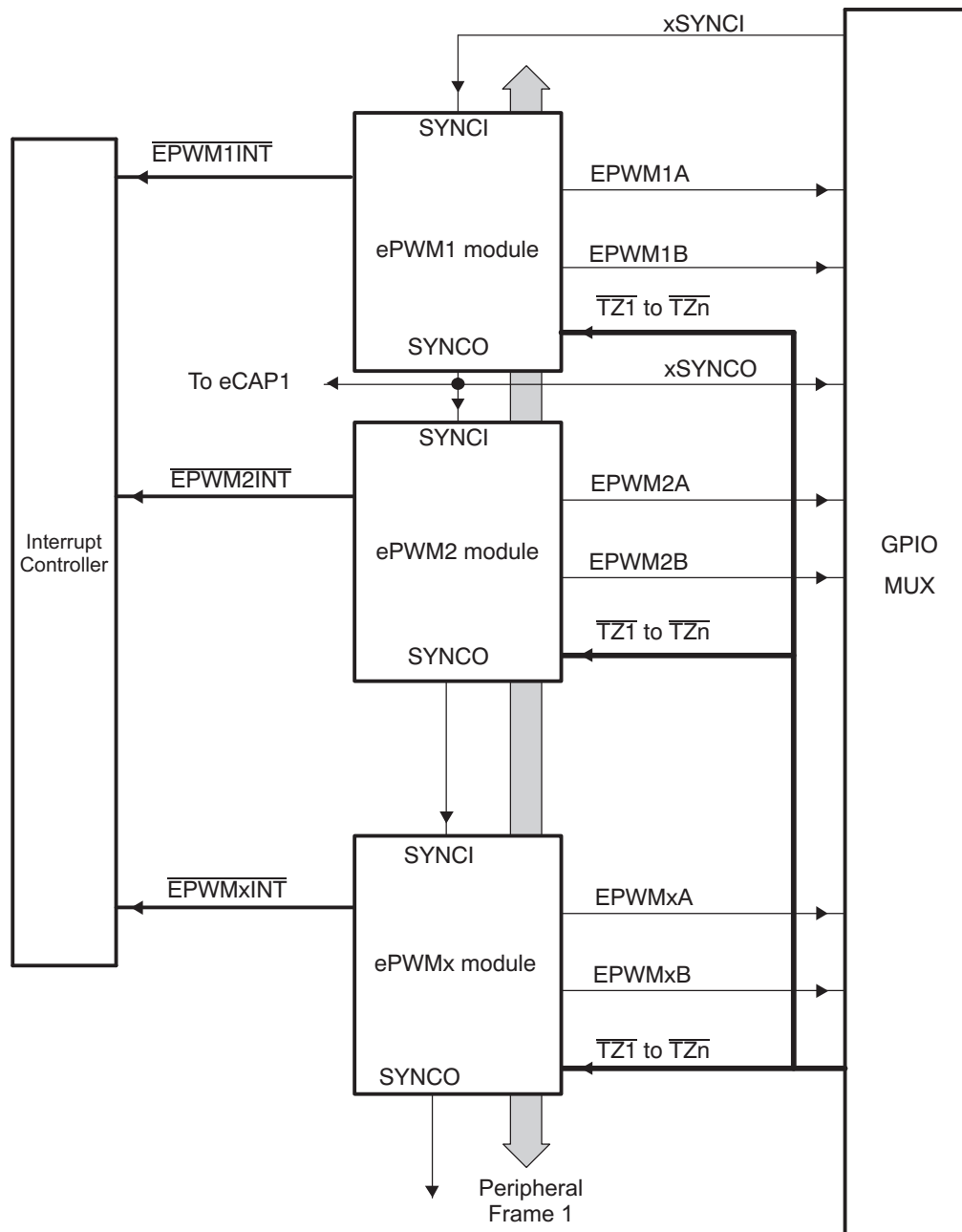

Figure 2. Submodules and Signal Connections for an ePWM Module

Figure 3 shows more internal details of a single ePWM module. The main signals used by the ePWM module are:

- **PWM output signals (EPWMxA and EPWMxB).** The PWM output signals are made available external to the device through the GPIO peripheral described in the system control and interrupts guide for your device.
- **Trip-zone signals ($\overline{TZ1}$ to \overline{TZn}).** These input signals alert the ePWM module of an external fault condition. Each module on a device can be configured to either use or ignore any of the trip-zone signals. The trip-zone signal can be configured as an asynchronous input through the GPIO peripheral. See your device-specific data manual to determine how many trip-zone pins are available in the device.
- **Time-base synchronization input (EPWMxSYNCI) and output (EPWMxSYNCO) signals.** The synchronization signals daisy chain the ePWM modules together. Each module can be configured to either use or ignore its synchronization input. The clock synchronization input and output signal are brought out to pins only for ePWM1 (ePWM module #1). The synchronization output for ePWM1 (EPWM1SYNCO) is also connected to the SYNCI of the first enhanced capture module (eCAP1).
- **Peripheral Bus.** The peripheral bus is 32-bits wide and allows both 16-bit and 32-bit writes to the ePWM register file.

Figure 3 also shows the key internal submodule interconnect signals. Each submodule is described in detail in [Section 2](#).

Figure 3. ePWM Submodules and Critical Internal Signal Interconnects

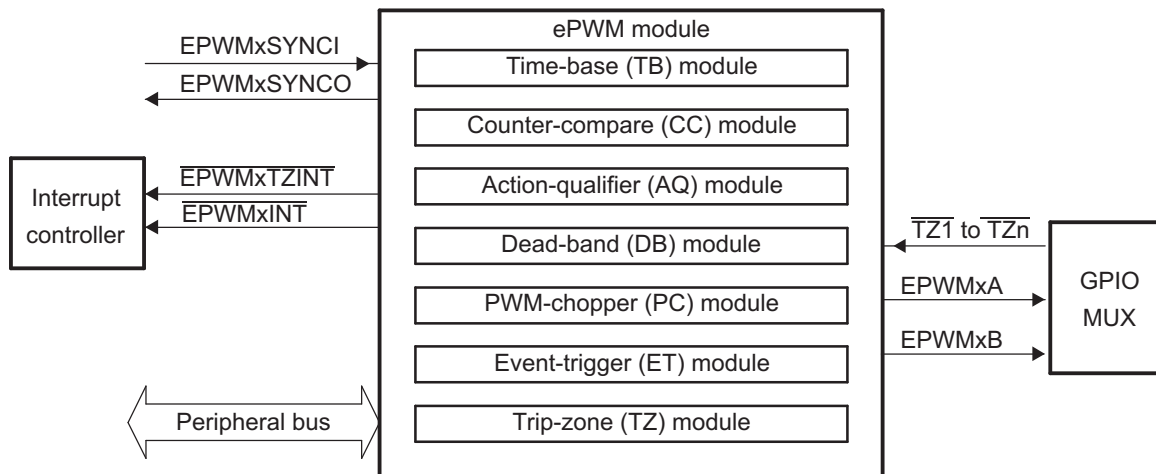
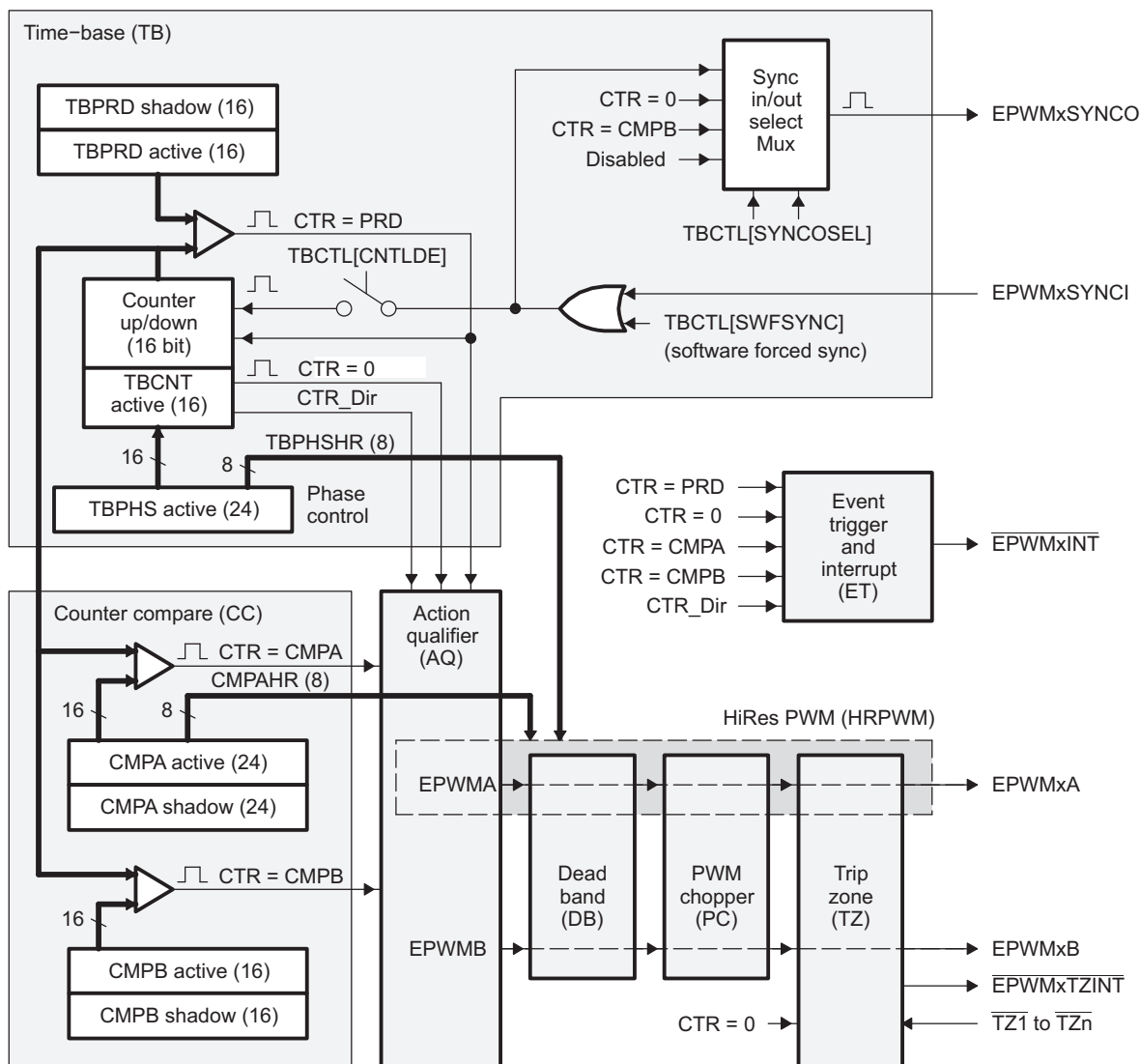

1.3 Register Mapping

Table 1 shows the complete ePWM module control and status register set grouped by submodule. Each register set is duplicated for each instance of the ePWM module. The start address for each ePWM register file instance on a device is specified in the appropriate data manual.

Table 1. ePWM Module Control and Status Registers Grouped by Submodule

Acronym	Offset ⁽¹⁾	Size (x16)	Shadow	Register Description
Time-Base Submodule Registers				
TBCTL	0h	1	No	Time-Base Control Register
TBSTS	2h	1	No	Time-Base Status Register
TBPHSHR	4h	1	No	Extension for HRPWM Phase Register ⁽²⁾
TBPHS	6h	1	No	Time-Base Phase Register
TBCNT	8h	1	No	Time-Base Counter Register
TBPRD	Ah	1	Yes	Time-Base Period Register
Counter-Compare Submodule Registers				
CMPCTL	Eh	1	No	Counter-Compare Control Register
CMPAHR	10h	1	No	Extension for HRPWM Counter-Compare A Register ⁽²⁾
CMPA	12h	1	Yes	Counter-Compare A Register
CMPB	14h	1	Yes	Counter-Compare B Register
Action-Qualifier Submodule Registers				
AQCTLA	16h	1	No	Action-Qualifier Control Register for Output A (EPWMxA)
AQCTLB	18h	1	No	Action-Qualifier Control Register for Output B (EPWMxB)
AQSFC	1Ah	1	No	Action-Qualifier Software Force Register
AQCSFC	1Ch	1	Yes	Action-Qualifier Continuous S/W Force Register Set
Dead-Band Generator Submodule Registers				
DBCTL	1Eh	1	No	Dead-Band Generator Control Register
DBRED	20h	1	No	Dead-Band Generator Rising Edge Delay Count Register
DBFED	22h	1	No	Dead-Band Generator Falling Edge Delay Count Register
PWM-Chopper Submodule Registers				
PCCTL	3Ch	1	No	PWM-Chopper Control Register
Trip-Zone Submodule Registers				
TZSEL	24h	1	No	Trip-Zone Select Register
TZCTL	28h	1	No	Trip-Zone Control Register ⁽³⁾
TZEINT	2Ah	1	No	Trip-Zone Enable Interrupt Register ⁽³⁾
TZFLG	2Ch	1	No	Trip-Zone Flag Register ⁽³⁾
TZCLR	2Eh	1	No	Trip-Zone Clear Register ⁽³⁾
TZFRC	30h	1	No	Trip-Zone Force Register ⁽³⁾
Event-Trigger Submodule Registers				
ETSEL	32h	1	No	Event-Trigger Selection Register
ETPS	34h	1	No	Event-Trigger Pre-Scale Register
ETFLG	36h	1	No	Event-Trigger Flag Register
ETCLR	38h	1	No	Event-Trigger Clear Register
ETFRC	3Ah	1	No	Event-Trigger Force Register
High-Resolution PWM (HRPWM) Submodule Registers				
HRCNFG	1020h	1	No	HRPWM Configuration Register ⁽²⁾

⁽¹⁾ Locations not shown are reserved.

⁽²⁾ These registers are only available on ePWM instances that include the high-resolution PWM (HRPWM) extension; otherwise, these locations are reserved. See your device-specific data manual to determine which instances include the HRPWM.

⁽³⁾ EALLOW protected registers as described in the device-specific data manual.

2 Architecture

Seven submodules are included in every ePWM peripheral. There are some instances that include a high-resolution submodule that allows more precise control of the PWM outputs. Each of these submodules performs specific tasks that can be configured by software.

2.1 Overview

[Table 2](#) lists the eight key submodules together with a list of their main configuration parameters. For example, if you need to adjust or control the duty cycle of a PWM waveform, then you should see the counter-compare submodule in [Section 2.4](#) for relevant details.

Table 2. Submodule Configuration Parameters

Submodule	Configuration Parameter or Option
Time-base (TB)	<ul style="list-style-type: none"> • Scale the time-base clock (TBCLK) relative to the system clock (SYSCLKOUT). • Configure the PWM time-base counter (TBCNT) frequency or period. • Set the mode for the time-base counter: <ul style="list-style-type: none"> – count-up mode: used for asymmetric PWM – count-down mode: used for asymmetric PWM – count-up-and-down mode: used for symmetric PWM • Configure the time-base phase relative to another ePWM module. • Synchronize the time-base counter between modules through hardware or software. • Configure the direction (up or down) of the time-base counter after a synchronization event. • Configure how the time-base counter will behave when the device is halted by an emulator. • Specify the source for the synchronization output of the ePWM module: <ul style="list-style-type: none"> – Synchronization input signal – Time-base counter equal to zero – Time-base counter equal to counter-compare B (CMPB) – No output synchronization signal generated.
Counter-compare (CC)	<ul style="list-style-type: none"> • Specify the PWM duty cycle for output EPWMxA and/or output EPWMxB • Specify the time at which switching events occur on the EPWMxA or EPWMxB output
Action-qualifier (AQ)	<ul style="list-style-type: none"> • Specify the type of action taken when a time-base or counter-compare submodule event occurs: <ul style="list-style-type: none"> – No action taken – Output EPWMxA and/or EPWMxB switched high – Output EPWMxA and/or EPWMxB switched low – Output EPWMxA and/or EPWMxB toggled • Force the PWM output state through software control • Configure and control the PWM dead-band through software
Dead-band (DB)	<ul style="list-style-type: none"> • Control of traditional complementary dead-band relationship between upper and lower switches • Specify the output rising-edge-delay value • Specify the output falling-edge delay value • Bypass the dead-band module entirely. In this case the PWM waveform is passed through without modification.
PWM-chopper (PC)	<ul style="list-style-type: none"> • Create a chopping (carrier) frequency. • Pulse width of the first pulse in the chopped pulse train. • Duty cycle of the second and subsequent pulses. • Bypass the PWM-chopper module entirely. In this case the PWM waveform is passed through without modification.

Table 2. Submodule Configuration Parameters (continued)

Submodule	Configuration Parameter or Option
Trip-zone (TZ)	<ul style="list-style-type: none"> • Configure the ePWM module to react to one, all, or none of the trip-zone pins. • Specify the tripping action taken when a fault occurs: <ul style="list-style-type: none"> – Force EPWMxA and/or EPWMxB high – Force EPWMxA and/or EPWMxB low – Force EPWMxA and/or EPWMxB to a high-impedance state – Configure EPWMxA and/or EPWMxB to ignore any trip condition. • Configure how often the ePWM will react to each trip-zone pin: <ul style="list-style-type: none"> – One-shot – Cycle-by-cycle • Enable the trip-zone to initiate an interrupt. • Bypass the trip-zone module entirely.
Event-trigger (ET)	<ul style="list-style-type: none"> • Enable the ePWM events that will trigger an interrupt. • Specify the rate at which events cause triggers (every occurrence or every second or third occurrence) • Poll, set, or clear event flags
High-Resolution PWM (HRPWM)	<ul style="list-style-type: none"> • Enable extended time resolution capabilities • Configure finer time granularity control or edge positioning

Code examples are provided in the remainder of this document that show how to implement various ePWM module configurations. These examples use the constant definitions shown in [Example 1](#).

Example 1. Constant Definitions Used in the Code Examples

```
// TBCTL (Time-Base Control)
// = = = = =
// TBCNT MODE bits
#define TB_COUNT_UP 0x0
#define TB_COUNT_DOWN 0x1
#define TB_COUNT_UPDOWN 0x2
#define TB_FREEZE 0x3
// PHSEN bit
#define TB_DISABLE 0x0
#define TB_ENABLE 0x1
// PRDL bit
#define TB_SHADOW 0x0
#define TB_IMMEDIATE 0x1
// SYNCSEL bits
#define TB_SYNC_IN 0x0
#define TB_CTR_ZERO 0x1
#define TB_CTR_CMPB 0x2
#define TB_SYNC_DISABLE 0x3
// HSPCLKDIV and CLKDIV bits
#define TB_DIV1 0x0
#define TB_DIV2 0x1
#define TB_DIV4 0x2
// PHSDIR bit
#define TB_DOWN 0x0
#define TB_UP 0x1
// CMPCTL (Compare Control)
// = = = = =
// LOADAMODE and LOADBMODE bits
#define CC_CTR_ZERO 0x0
#define CC_CTR_PRD 0x1
#define CC_CTR_ZERO_PRD 0x2
#define CC_LD_DISABLE 0x3
// SHDWAMODE and SHDWBMODE bits
#define CC_SHADOW 0x0
#define CC_IMMEDIATE 0x1
// AQCTLA and AQCTLB (Action-qualifier Control)
// = = = = =
// ZRO, PRD, CAU, CAD, CBU, CBD bits
```

Example 1. Constant Definitions Used in the Code Examples (continued)

```

#define      AQ_NO_ACTION      0x0
#define      AQ_CLEAR          0x1
#define      AQ_SET            0x2
#define      AQ_TOGGLE         0x3
// DBCTL (Dead-Band Control)
// = = = = =
// MODE bits
#define      DB_DISABLE        0x0
#define      DBA_ENABLE        0x1
#define      DBB_ENABLE        0x2
#define      DB_FULL_ENABLE    0x3
// POLSEL bits
#define      DB_ACTV_HI        0x0
#define      DB_ACTV_LO        0x1
#define      DB_ACTV_HIC       0x2
#define      DB_ACTV_LO        0x3
// PCCTL (chopper control)
// = = = = =
// CHPEN bit
#define      CHP_ENABLE        0x0
#define      CHP_DISABLE       0x1
// CHPFREQ bits
#define      CHP_DIV1          0x0
#define      CHP_DIV2          0x1
#define      CHP_DIV3          0x2
#define      CHP_DIV4          0x3
#define      CHP_DIV5          0x4
#define      CHP_DIV6          0x5
#define      CHP_DIV7          0x6
#define      CHP_DIV8          0x7
// CHPDUTY bits
#define      CHP1_8TH          0x0
#define      CHP2_8TH          0x1
#define      CHP3_8TH          0x2
#define      CHP4_8TH          0x3
#define      CHP5_8TH          0x4
#define      CHP6_8TH          0x5
#define      CHP7_8TH          0x6
// TZSEL (Trip-zone Select)
// = = = = =
// CBCn and OSHTn bits
#define      TZ_ENABLE         0x0
#define      TZ_DISABLE        0x1
// TZCTL (Trip-zone Control)
// = = = = =
// TZA and TZB bits
#define      TZ_HIZ            0x0
#define      TZ_FORCE_HI       0x1
#define      TZ_FORCE_LO       0x2
#define      TZ_DISABLE        0x3
// ETSEL (Event-trigger Select)
// = = = = =
// INTSEL, SOCASEL, SOCBSEL bits
#define      ET_CTR_ZERO       0x1
#define      ET_CTR_PRD        0x2
#define      ET_CTRU_CMPA      0x4
#define      ET_CTRD_CMPA      0x5
#define      ET_CTRU_CMPB      0x6
#define      ET_CTRD_CMPB      0x7
// ETPS (Event-trigger Prescale)
// = = = = =
// INTPRD, SOCAPRD, SOCBPRD bits
#define      ET_DISABLE        0x0
#define      ET_1ST            0x1
#define      ET_2ND            0x2
#define      ET_3RD            0x3

```

2.2 Proper Interrupt Initialization Procedure

When the ePWM peripheral clock is enabled it may be possible that interrupt flags may be set due to spurious events due to the ePWM registers not being properly initialized. The proper procedure for initializing the ePWM peripheral is:

1. Disable global interrupts (CPU INTM flag)
2. Disable ePWM interrupts
3. Initialize peripheral registers
4. Clear any spurious ePWM flags
5. Enable ePWM interrupts
6. Enable global interrupts

2.3 Time-Base (TB) Submodule

Each ePWM module has its own time-base submodule that determines all of the event timing for the ePWM module. Built-in synchronization logic allows the time-base of multiple ePWM modules to work together as a single system. Figure 4 illustrates the time-base module's place within the ePWM.

Figure 4. Time-Base Submodule Block Diagram

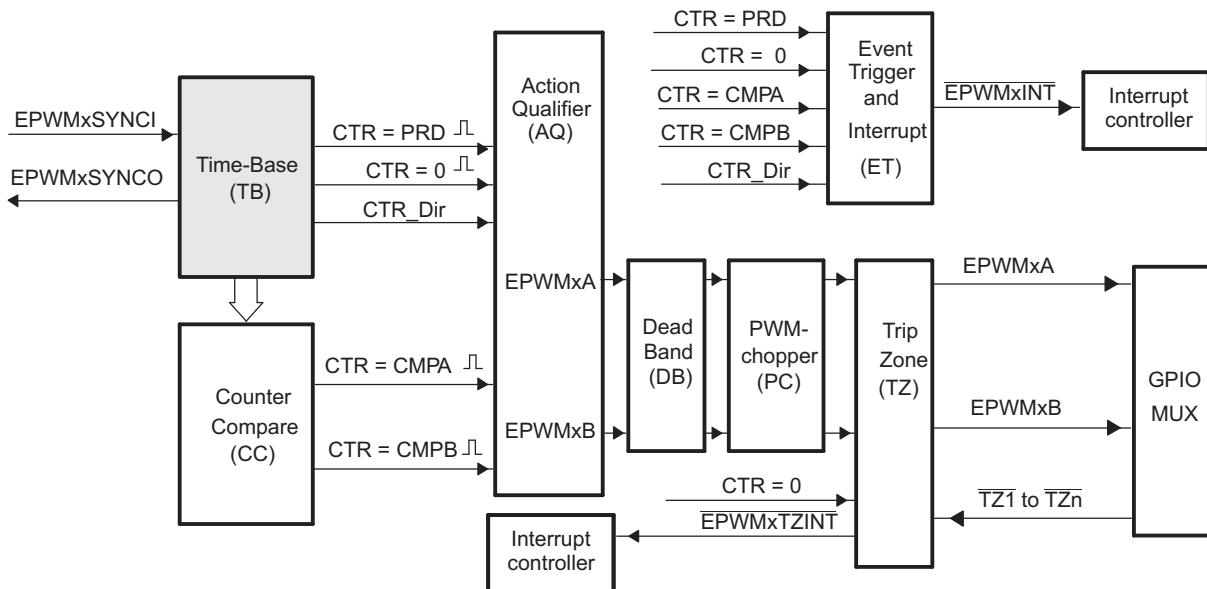

2.3.1 Purpose of the Time-Base Submodule

You can configure the time-base submodule for the following:

- Specify the ePWM time-base counter (TBCNT) frequency or period to control how often events occur.
- Manage time-base synchronization with other ePWM modules.
- Maintain a phase relationship with other ePWM modules.
- Set the time-base counter to count-up, count-down, or count-up-and-down mode.
- Generate the following events:
 - CTR = PRD: Time-base counter equal to the specified period (TBCNT = TBPRD) .
 - CTR = 0: Time-base counter equal to zero (TBCNT = 0000h).
- Configure the rate of the time-base clock; a prescaled version of the CPU system clock (SYSCLKOUT). This allows the time-base counter to increment/decrement at a slower rate.

Table 4. Key Time-Base Signals

Signal	Description
EPWMxSYNCl	Time-base synchronization input. Input pulse used to synchronize the time-base counter with the counter of ePWM module earlier in the synchronization chain. An ePWM peripheral can be configured to use or ignore this signal. For the first ePWM module (EPWM1) this signal comes from a device pin. For subsequent ePWM modules this signal is passed from another ePWM peripheral. For example, EPWM2SYNCl is generated by the ePWM1 peripheral, EPWM3SYNCl is generated by ePWM2 and so forth. See Section 2.3.3.2 for information on the synchronization order of a particular device.
EPWMxSYNCO	Time-base synchronization output. This output pulse is used to synchronize the counter of an ePWM module later in the synchronization chain. The ePWM module generates this signal from one of three event sources: <ol style="list-style-type: none"> EPWMxSYNCl (Synchronization input pulse) CTR = 0: The time-base counter equal to zero (TBCNT = 0000h). CTR = CMPB: The time-base counter equal to the counter-compare B (TBCNT = CMPB) register.
CTR = PRD	Time-base counter equal to the specified period. This signal is generated whenever the counter value is equal to the active period register value. That is when TBCNT = TBPRD.
CTR = 0	Time-base counter equal to zero. This signal is generated whenever the counter value is zero. That is when TBCNT equals 0000h.
CTR = CMPB	Time-base counter equal to active counter-compare B register (TBCNT = CMPB). This event is generated by the counter-compare submodule and used by the synchronization out logic.
CTR_dir	Time-base counter direction. Indicates the current direction of the ePWM's time-base counter. This signal is high when the counter is increasing and low when it is decreasing.
CTR_max	Time-base counter equal max value. (TBCNT = FFFFh) Generated event when the TBCNT value reaches its maximum value. This signal is only used only as a status bit.
TBCLK	Time-base clock. This is a prescaled version of the system clock (SYSCLKOUT) and is used by all submodules within the ePWM. This clock determines the rate at which time-base counter increments or decrements.

2.3.3 Calculating PWM Period and Frequency

The frequency of PWM events is controlled by the time-base period (TBPRD) register and the mode of the time-base counter. [Figure 6](#) shows the period (T_{pwm}) and frequency (F_{pwm}) relationships for the up-count, down-count, and up-down-count time-base counter modes when the period is set to 4 (TBPRD = 4). The time increment for each step is defined by the time-base clock (TBCLK) which is a prescaled version of the system clock (SYSCLKOUT).

The time-base counter has three modes of operation selected by the time-base control register (TBCTL):

- **Up-Down-Count Mode:** In up-down-count mode, the time-base counter starts from zero and increments until the period (TBPRD) value is reached. When the period value is reached, the time-base counter then decrements until it reaches zero. At this point the counter repeats the pattern and begins to increment.
- **Up-Count Mode:** In this mode, the time-base counter starts from zero and increments until it reaches the value in the period register (TBPRD). When the period value is reached, the time-base counter resets to zero and begins to increment once again.
- **Down-Count Mode:** In down-count mode, the time-base counter starts from the period (TBPRD) value and decrements until it reaches zero. When it reaches zero, the time-base counter is reset to the period value and it begins to decrement once again.

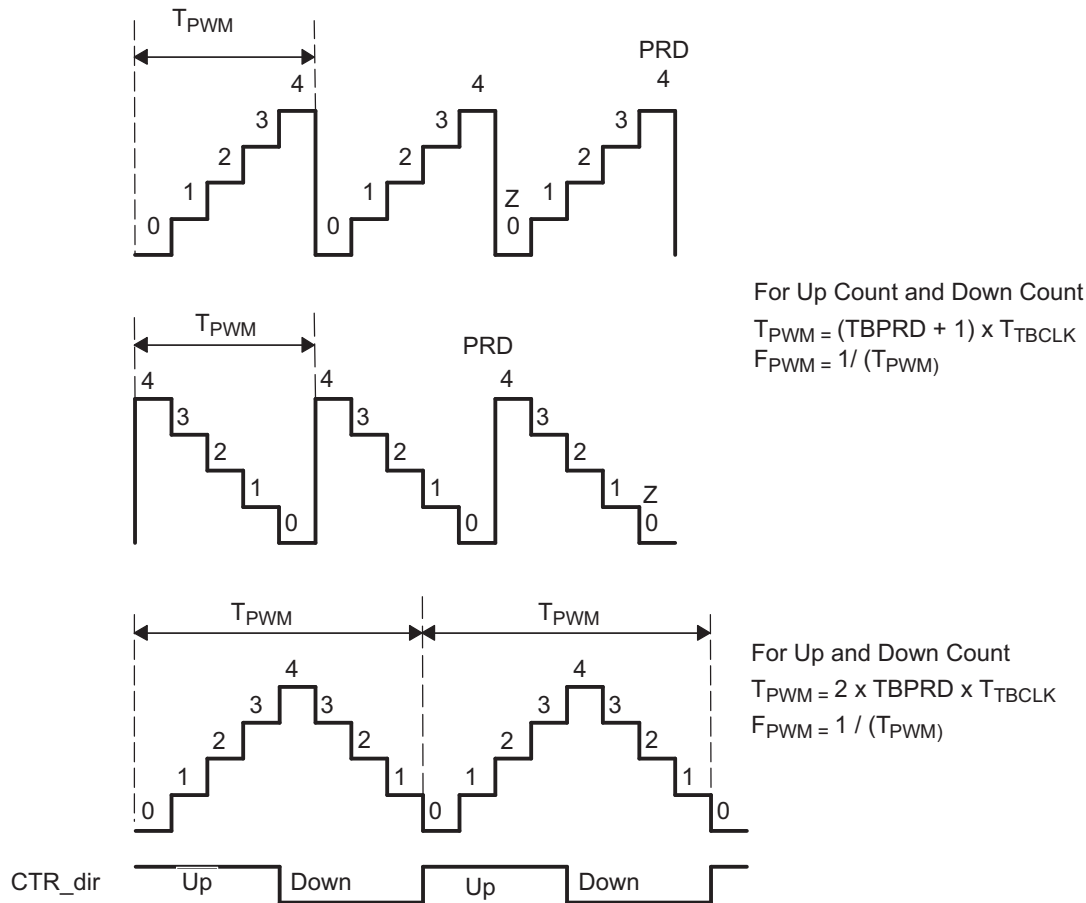
Figure 6. Time-Base Frequency and Period

2.3.3.1 Time-Base Period Shadow Register

The time-base period register (TBPRD) has a shadow register. Shadowing allows the register update to be synchronized with the hardware. The following definitions are used to describe all shadow registers in the ePWM module:

- **Active Register:** The active register controls the hardware and is responsible for actions that the hardware causes or invokes.
- **Shadow Register:** The shadow register buffers or provides a temporary holding location for the active register. It has no direct effect on any control hardware. At a strategic point in time the shadow register's content is transferred to the active register. This prevents corruption or spurious operation due to the register being asynchronously modified by software.

The memory address of the shadow period register is the same as the active register. Which register is written to or read from is determined by the TBCTL[PRDLD] bit. This bit enables and disables the TBPRD shadow register as follows:

- **Time-Base Period Shadow Mode:** The TBPRD shadow register is enabled when TBCTL[PRDLD] = 0. Reads from and writes to the TBPRD memory address go to the shadow register. The shadow register contents are transferred to the active register (TBPRD (Active) ← TBPRD (shadow)) when the time-base counter equals zero (TBCNT = 0000h). By default the TBPRD shadow register is enabled.
- **Time-Base Period Immediate Load Mode:** If immediate load mode is selected (TBCTL[PRDLD] = 1), then a read from or a write to the TBPRD memory address goes directly to the active register.

2.3.3.2 Time-Base Counter Synchronization

A time-base synchronization scheme connects all of the ePWM modules on a device. Each ePWM module has a synchronization input (EPWMxSYNCl) and a synchronization output (EPWMxSYNCO). The input synchronization for the first instance (ePWM1) comes from an external pin. The possible synchronization connections for the remaining ePWM modules is shown in [Figure 7](#).

Figure 7. Time-Base Counter Synchronization Scheme 1

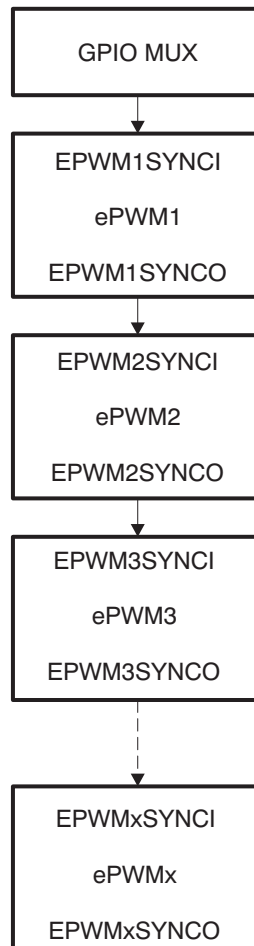

Each ePWM module can be configured to use or ignore the synchronization input. If the TBCTL[PHSEN] bit is set, then the time-base counter (TBCNT) of the ePWM module will be automatically loaded with the phase register (TBPHS) contents when one of the following conditions occur:

- **EPWMxSYNCl: Synchronization Input Pulse:** The value of the phase register is loaded into the counter register when an input synchronization pulse is detected (TBPHS → TBCNT). This operation occurs on the next valid time-base clock (TBCLK) edge.
- **Software Forced Synchronization Pulse:** Writing a 1 to the TBCTL[SWFSYNC] control bit invokes a software forced synchronization. This pulse is ORed with the synchronization input signal, and therefore has the same effect as a pulse on EPWMxSYNCl.

This feature enables the ePWM module to be automatically synchronized to the time base of another ePWM module. Lead or lag phase control can be added to the waveforms generated by different ePWM modules to synchronize them. In up-down-count mode, the TBCTL[PSHDIR] bit configures the direction of the time-base counter immediately after a synchronization event. The new direction is independent of the direction prior to the synchronization event. The TBPHS bit is ignored in count-up or count-down modes. See [Figure 8](#) through [Figure 11](#) for examples.

Clearing the TBCTL[PHSEN] bit configures the ePWM to ignore the synchronization input pulse. The synchronization pulse can still be allowed to flow-through to the EPWMxSYNCO and be used to synchronize other ePWM modules. In this way, you can set up a master time-base (for example, ePWM1) and downstream modules (ePWM2 - ePWMx) may elect to run in synchronization with the master.

2.3.4 Phase Locking the Time-Base Clocks of Multiple ePWM Modules

The TBCLKSYNC bit in the chip configuration register 1 (CFGCHIP1) in the System Module can be used to globally synchronize the time-base clocks of all enabled ePWM modules on a device. The TBCLKSYNC bit is part of the chip configuration registers and is described in the device-specific data manual. When TBCLKSYNC = 0, the time-base clock of all ePWM modules is stopped (default). When TBCLKSYNC = 1, all ePWM time-base clocks are started with the rising edge of TBCLK aligned. For perfectly synchronized TBCLKs, the prescaler bits in the TBCTL register of each ePWM module must be set identically. The proper procedure for enabling the ePWM clocks is as follows:

1. Enable the ePWM module clocks.
2. Set TBCLKSYNC = 0. This will stop the time-base clock within any enabled ePWM module.
3. Configure the prescaler values and desired ePWM modes.
4. Set TBCLKSYNC = 1.

2.3.5 Time-Base Counter Modes and Timing Waveforms

The time-base counter operates in one of four modes:

- Up-count mode which is asymmetrical.
- Down-count mode which is asymmetrical.
- Up-down-count which is symmetrical.
- Frozen where the time-base counter is held constant at the current value.

To illustrate the operation of the first three modes, [Figure 8](#) to [Figure 11](#) show when events are generated and how the time-base responds to an EPWMxSYNCl signal.

Figure 8. Time-Base Up-Count Mode Waveforms

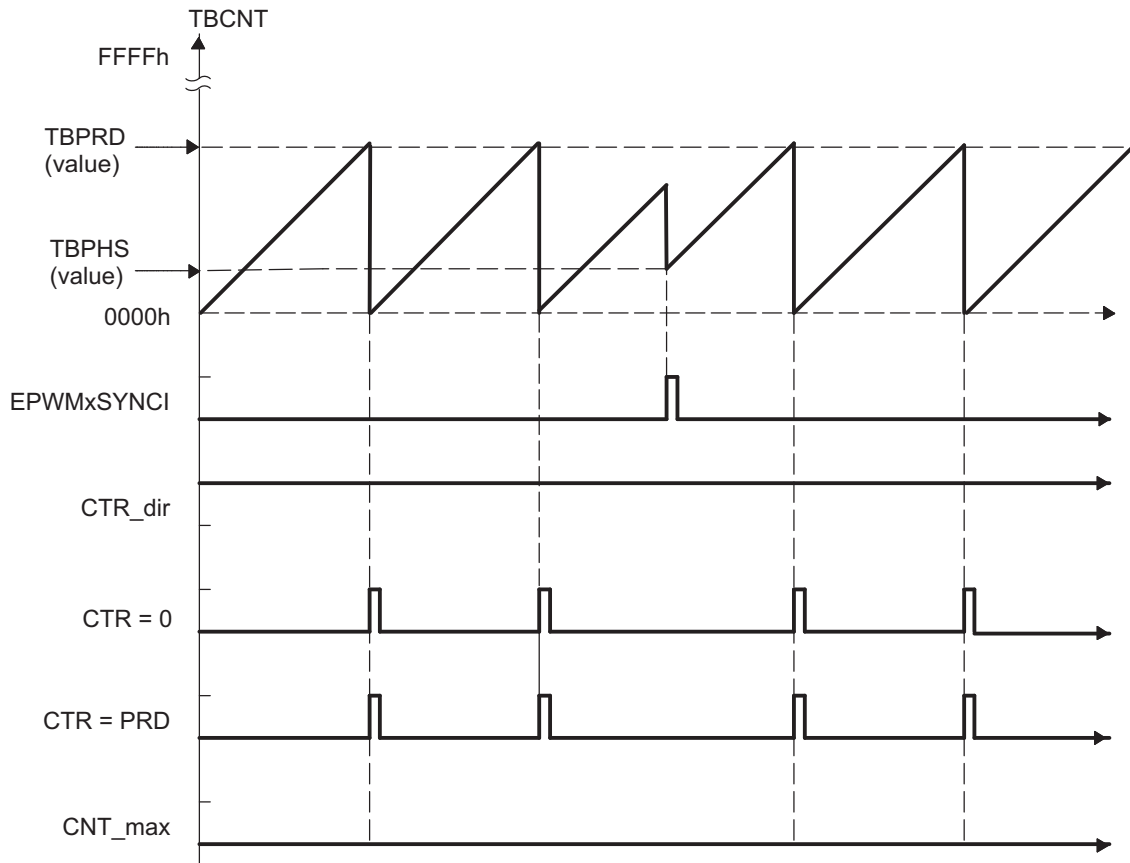

Figure 9. Time-Base Down-Count Mode Waveforms

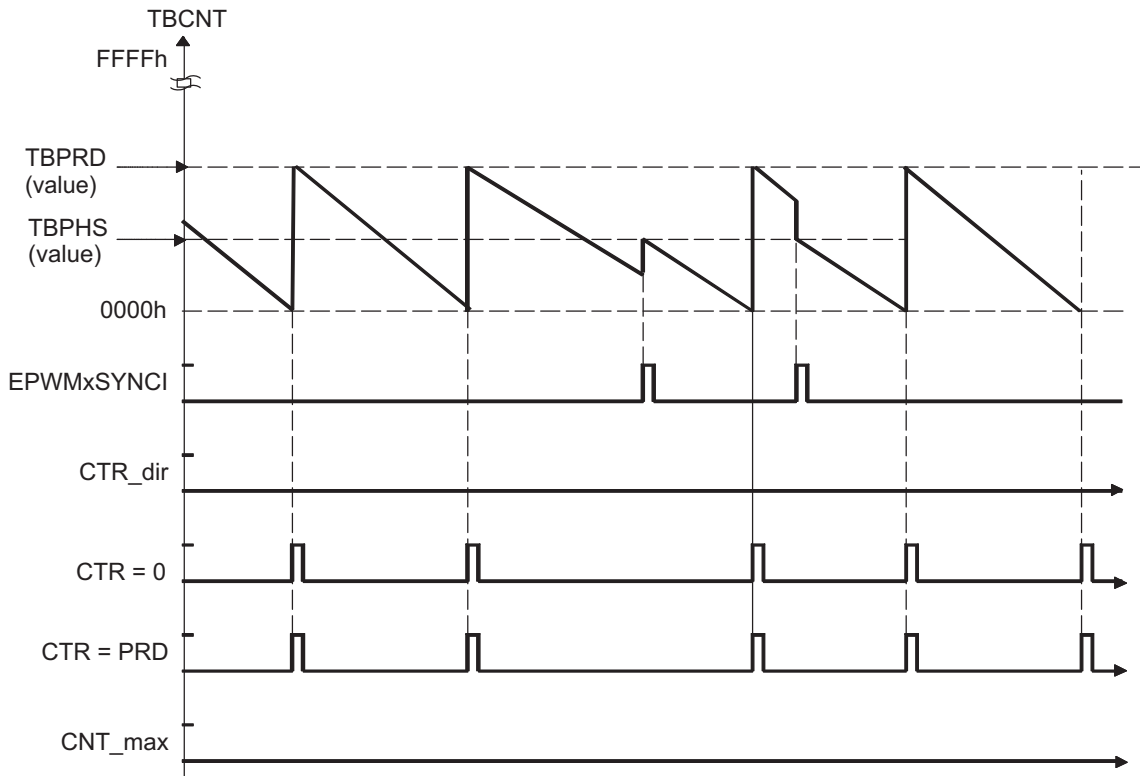

Figure 10. Time-Base Up-Down-Count Waveforms, TBCTL[PHSDIR = 0] Count Down on Synchronization Event

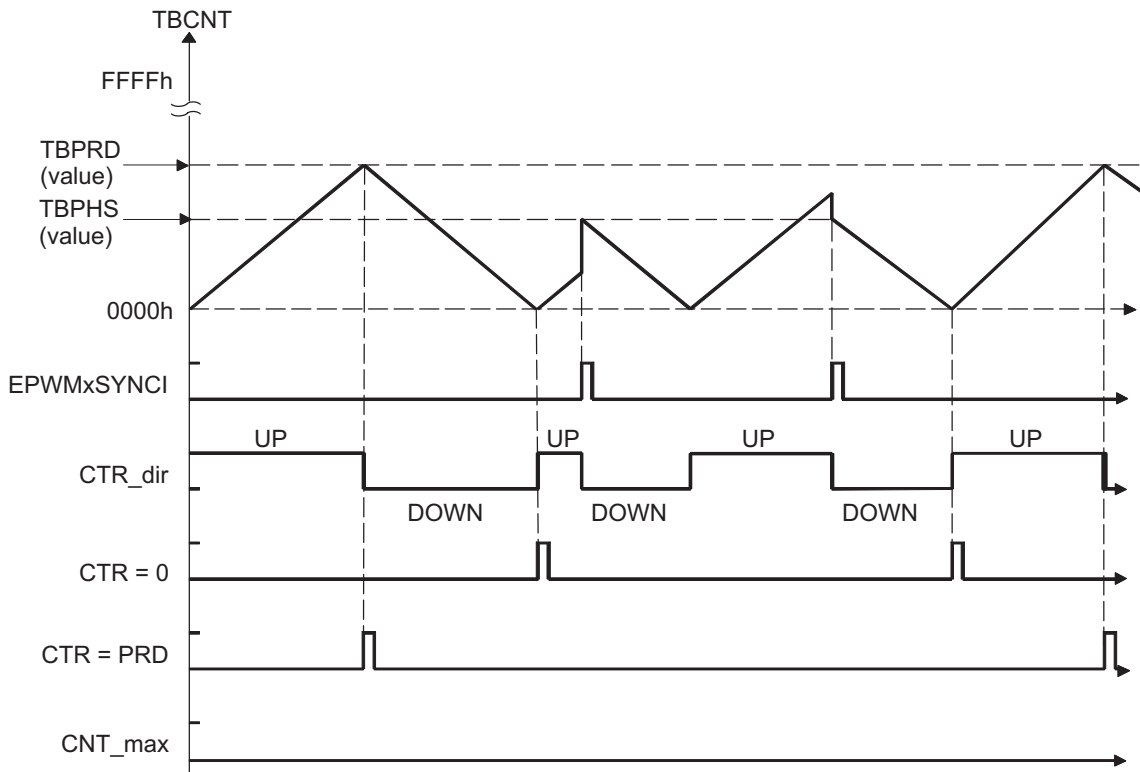
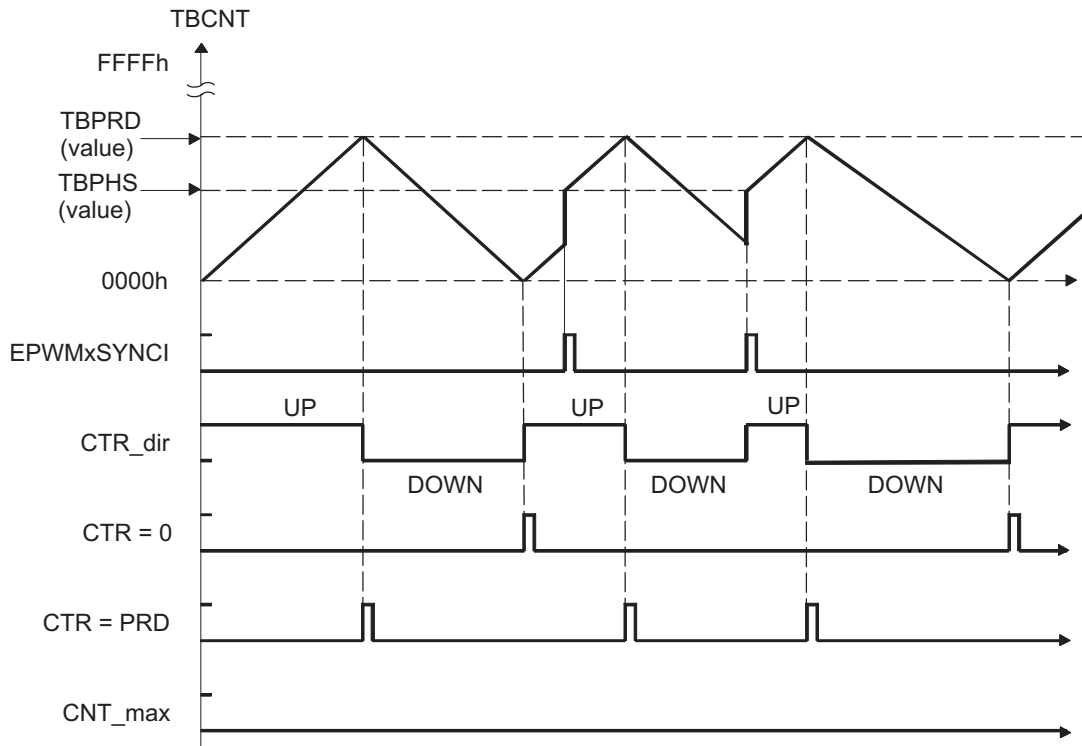

Figure 11. Time-Base Up-Down Count Waveforms, TBCTL[PHSDIR = 1] Count Up on Synchronization Event



2.4 Counter-Compare (CC) Submodule

Figure 12 illustrates the counter-compare submodule within the ePWM. Figure 13 shows the basic structure of the counter-compare submodule.

Figure 12. Counter-Compare Submodule

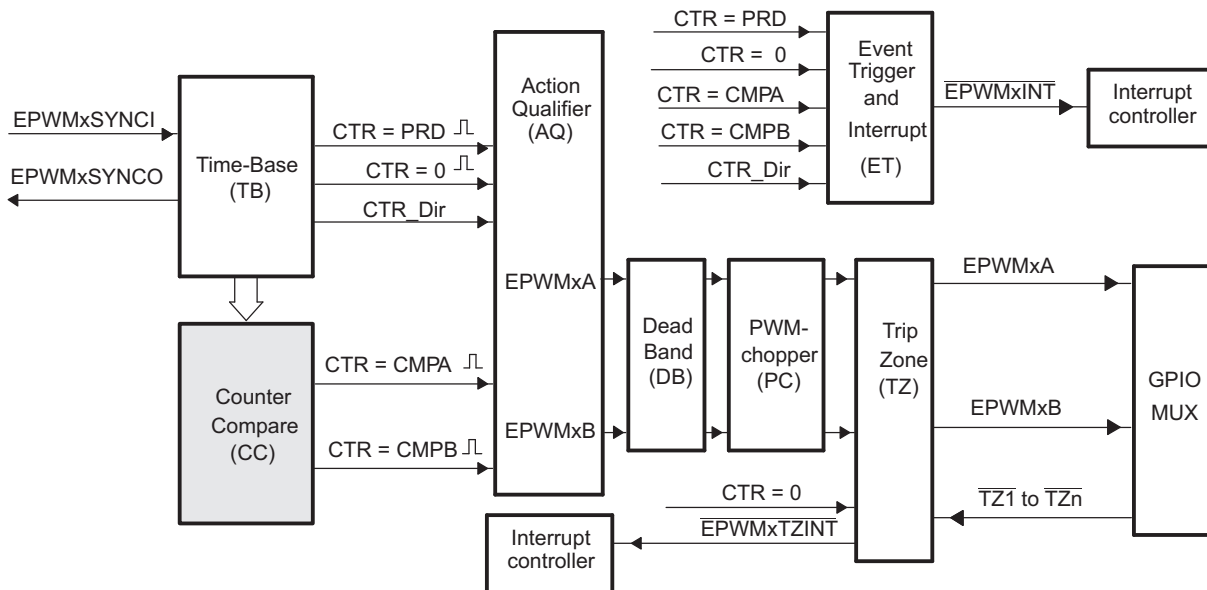
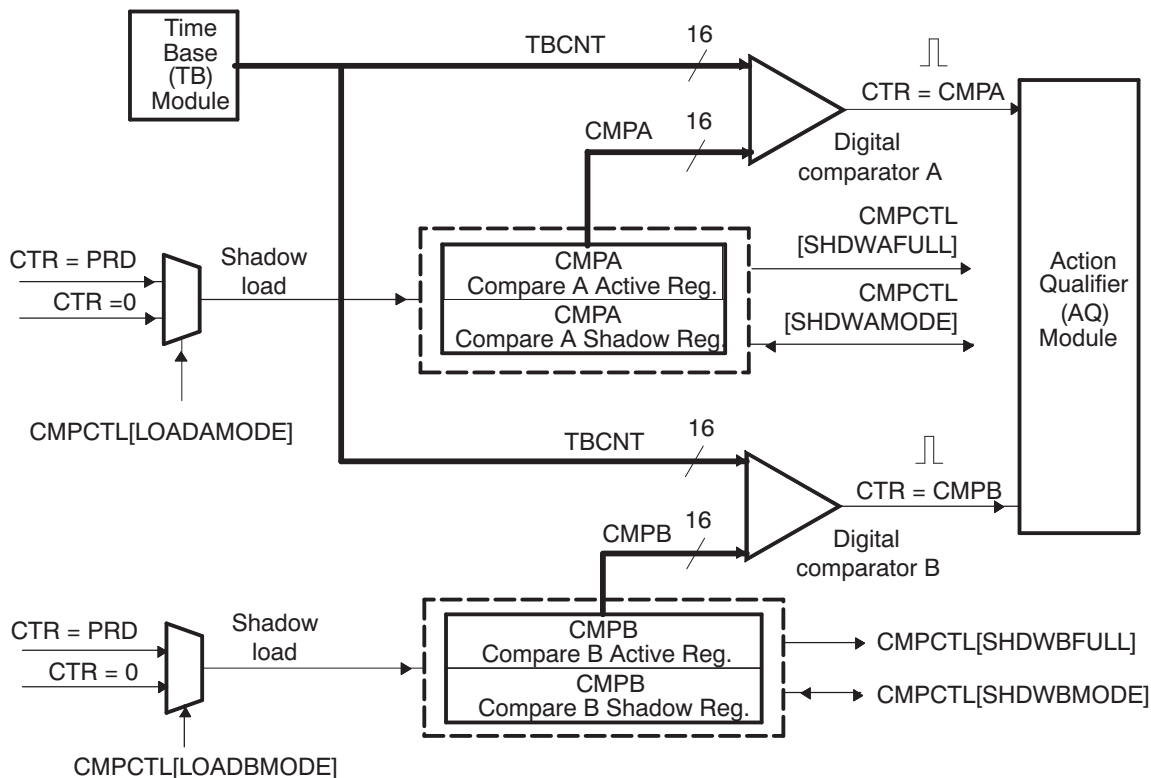

Figure 13. Counter-Compare Submodule Signals and Registers



2.4.1 Purpose of the Counter-Compare Submodule

The counter-compare submodule takes as input the time-base counter value. This value is continuously compared to the counter-compare A (CMPA) and counter-compare B (CMPB) registers. When the time-base counter is equal to one of the compare registers, the counter-compare unit generates an appropriate event.

The counter-compare submodule:

- Generates events based on programmable time stamps using the CMPA and CMPB registers
 - CTR = CMPA: Time-base counter equals counter-compare A register (TBCNT = CMPA).
 - CTR = CMPB: Time-base counter equals counter-compare B register (TBCNT = CMPB)
- Controls the PWM duty cycle if the action-qualifier submodule is configured appropriately
- Shadows new compare values to prevent corruption or glitches during the active PWM cycle

2.4.2 Controlling and Monitoring the Counter-Compare Submodule

Table 5 lists the registers used to control and monitor the counter-compare submodule. Table 6 lists the key signals associated with the counter-compare submodule.

Table 5. Counter-Compare Submodule Registers

Acronym	Register Description	Address Offset	Shadowed
CMPCTL	Counter-Compare Control Register.	Eh	No
CMPAHR	HRPWM Counter-Compare A Extension Register ⁽¹⁾	10h	Yes
CMPA	Counter-Compare A Register	12h	Yes
CMPB	Counter-Compare B Register	14h	Yes

⁽¹⁾ This register is available only on ePWM modules with the high-resolution extension (HRPWM). On ePWM modules that do not include the HRPWM, this location is reserved. Refer to the device-specific data manual to determine which ePWM instances include this feature.

Table 6. Counter-Compare Submodule Key Signals

Signal	Description of Event	Registers Compared
CTR = CMPA	Time-base counter equal to the active counter-compare A value	TBCNT = CMPA
CTR = CMPB	Time-base counter equal to the active counter-compare B value	TBCNT = CMPB
CTR = PRD	Time-base counter equal to the active period. Used to load active counter-compare A and B registers from the shadow register	TBCNT = TBPRD
CTR = 0	Time-base counter equal to zero. Used to load active counter-compare A and B registers from the shadow register	TBCNT = 0000h

2.4.3 Operational Highlights for the Counter-Compare Submodule

The counter-compare submodule is responsible for generating two independent compare events based on two compare registers:

1. CTR = CMPA: Time-base counter equal to counter-compare A register (TBCNT = CMPA).
2. CTR = CMPB: Time-base counter equal to counter-compare B register (TBCNT = CMPB).

For up-count or down-count mode, each event occurs only once per cycle. For up-down-count mode each event occurs twice per cycle, if the compare value is between 0000h and TBPRD; and occurs once per cycle, if the compare value is equal to 0000h or equal to TBPRD. These events are fed into the action-qualifier submodule where they are qualified by the counter direction and converted into actions if enabled. Refer to [Section 2.5.1](#) for more details.

The counter-compare registers CMPA and CMPB each have an associated shadow register. Shadowing provides a way to keep updates to the registers synchronized with the hardware. When shadowing is used, updates to the active registers only occurs at strategic points. This prevents corruption or spurious operation due to the register being asynchronously modified by software. The memory address of the active register and the shadow register is identical. Which register is written to or read from is determined by the CMPCTL[SHDWAMODE] and CMPCTL[SHDWBMODE] bits. These bits enable and disable the CMPA shadow register and CMPB shadow register respectively. The behavior of the two load modes is described below:

- **Shadow Mode:** The shadow mode for the CMPA is enabled by clearing the CMPCTL[SHDWAMODE] bit and the shadow register for CMPB is enabled by clearing the CMPCTL[SHDWBMODE] bit. Shadow mode is enabled by default for both CMPA and CMPB.

If the shadow register is enabled then the content of the shadow register is transferred to the active register on one of the following events:

- CTR = PRD: Time-base counter equal to the period (TBCNT = TBPRD).
- CTR = 0: Time-base counter equal to zero (TBCNT = 0000h)
- Both CTR = PRD and CTR = 0

Which of these three events is specified by the CMPCTL[LOADAMODE] and CMPCTL[LOADBMODE] register bits. Only the active register contents are used by the counter-compare submodule to generate events to be sent to the action-qualifier.

- **Immediate Load Mode:** If immediate load mode is selected (TBCTL[SHADWAMODE] = 1 or TBCTL[SHADWBMODE] = 1), then a read from or a write to the register will go directly to the active register.

2.4.4 Count Mode Timing Waveforms

The counter-compare module can generate compare events in all three count modes:

- Up-count mode: used to generate an asymmetrical PWM waveform.
- Down-count mode: used to generate an asymmetrical PWM waveform.
- Up-down-count mode: used to generate a symmetrical PWM waveform.

To best illustrate the operation of the first three modes, the timing diagrams in [Figure 14](#) to [Figure 17](#) show when events are generated and how the EPWMxSYNCl signal interacts.

Figure 14. Counter-Compare Event Waveforms in Up-Count Mode

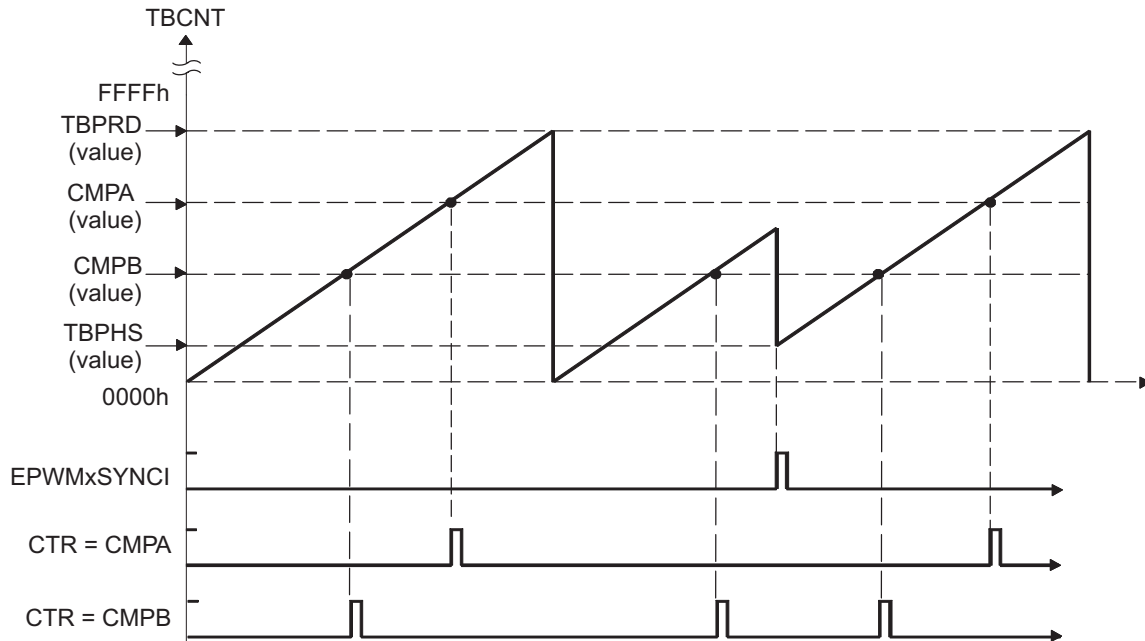

NOTE: An EPWMxSYNCl external synchronization event can cause a discontinuity in the TBCNT count sequence. This can lead to a compare event being skipped. This skipping is considered normal operation and must be taken into account.

Figure 15. Counter-Compare Events in Down-Count Mode

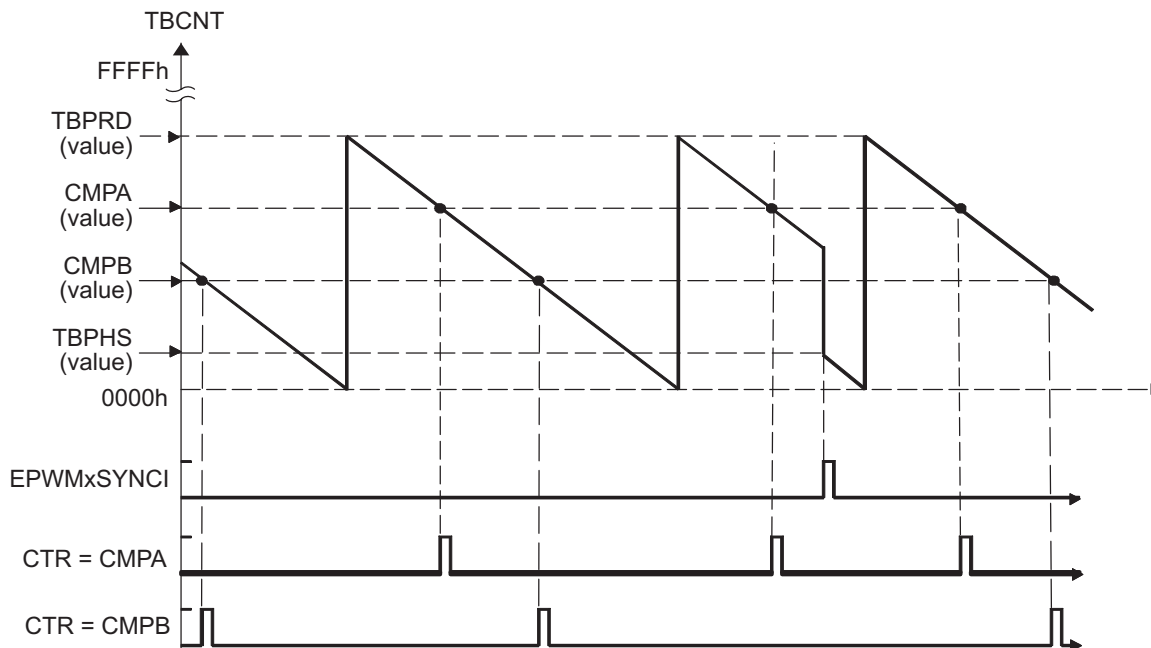

Figure 16. Counter-Compare Events in Up-Down-Count Mode, TBCTL[PHSDIR = 0] Count Down on Synchronization Event

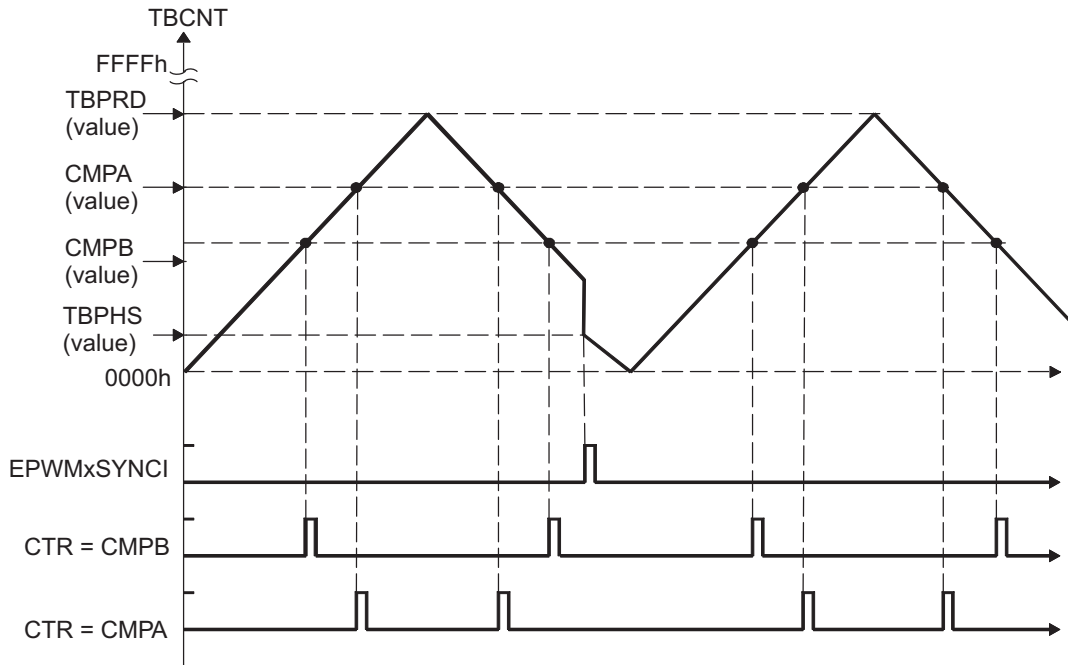
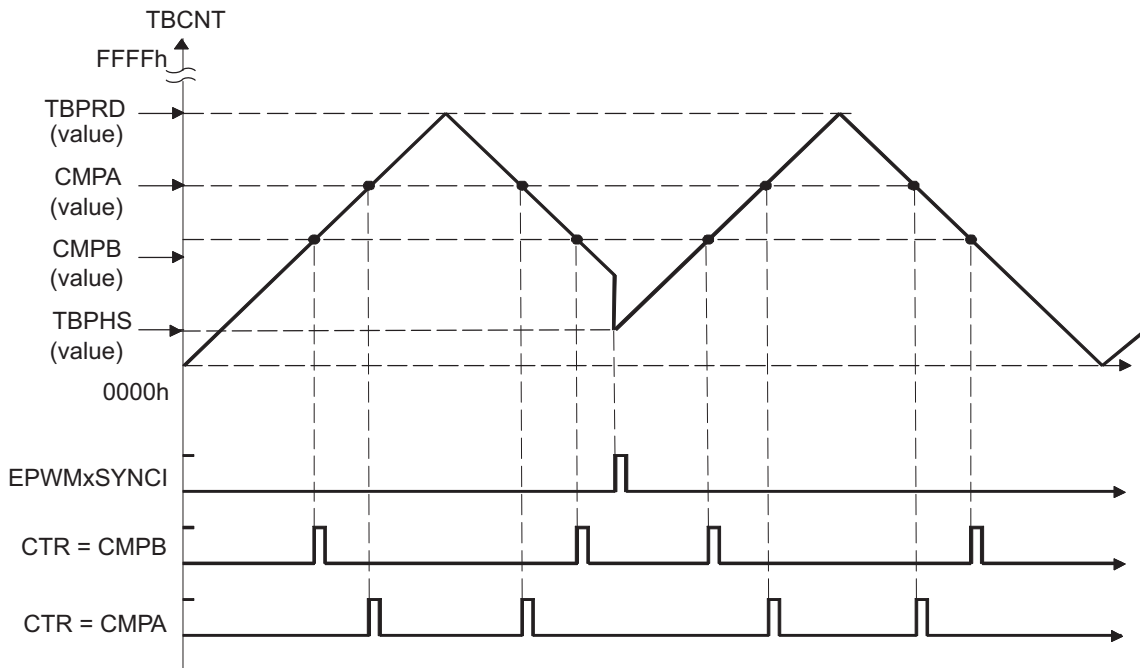

Figure 17. Counter-Compare Events in Up-Down-Count Mode, TBCTL[PHSDIR = 1] Count Up on Synchronization Event



2.5 Action-Qualifier (AQ) Submodule

Figure 18 shows the action-qualifier (AQ) submodule (see shaded block) in the ePWM system. The action-qualifier submodule has the most important role in waveform construction and PWM generation. It decides which events are converted into various action types, thereby producing the required switched waveforms at the EPWMxA and EPWMxB outputs.

Figure 18. Action-Qualifier Submodule

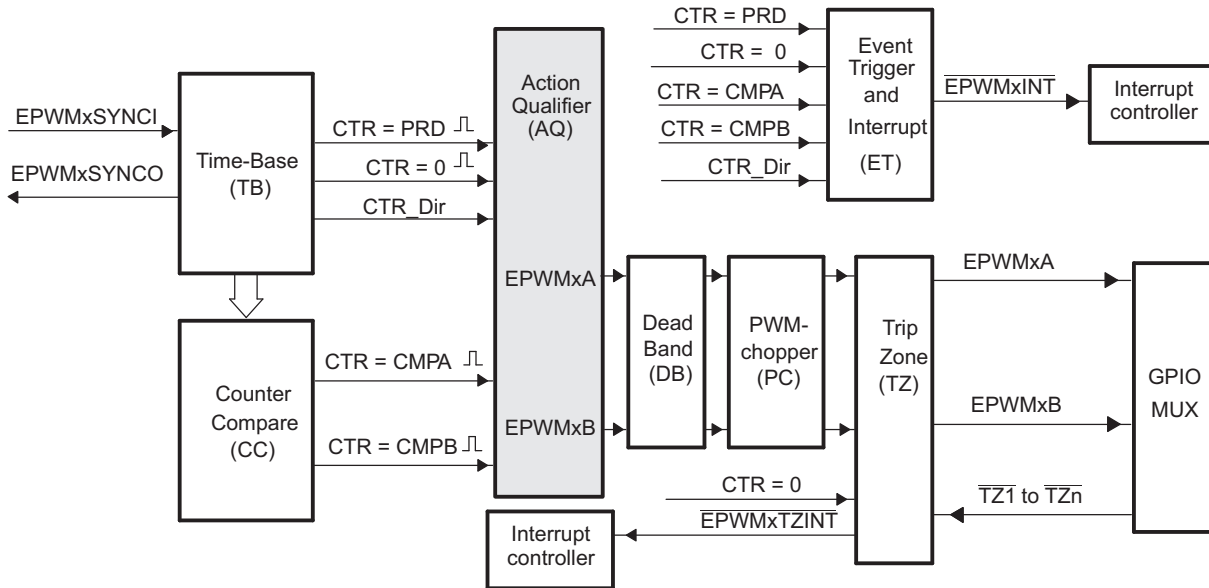

2.5.1 Purpose of the Action-Qualifier Submodule

The action-qualifier submodule is responsible for the following:

- Qualifying and generating actions (set, clear, toggle) based on the following events:
 - CTR = PRD: Time-base counter equal to the period (TBCNT = TBPRD)
 - CTR = 0: Time-base counter equal to zero (TBCNT = 0000h)
 - CTR = CMPA: Time-base counter equal to the counter-compare A register (TBCNT = CMPA)
 - CTR = CMPB: Time-base counter equal to the counter-compare B register (TBCNT = CMPB)
- Managing priority when these events occur concurrently
- Providing independent control of events when the time-base counter is increasing and when it is decreasing.

2.5.2 Controlling and Monitoring the Action-Qualifier Submodule

Table 7 lists the registers used to control and monitor the action-qualifier submodule.

Table 7. Action-Qualifier Submodule Registers

Acronym	Register Description	Address Offset	Shadowed
AQCTLA	Action-Qualifier Control Register For Output A (EPWMxA)	16h	No
AQCTLB	Action-Qualifier Control Register For Output B (EPWMxB)	18h	No
AQSFRC	Action-Qualifier Software Force Register	1Ah	No
AQCSFRC	Action-Qualifier Continuous Software Force	1Ch	Yes

The action-qualifier submodule is based on event-driven logic. It can be thought of as a programmable cross switch with events at the input and actions at the output, all of which are software controlled via the set of registers shown in [Figure 19](#). The possible input events are summarized again in [Table 8](#).

Figure 19. Action-Qualifier Submodule Inputs and Outputs

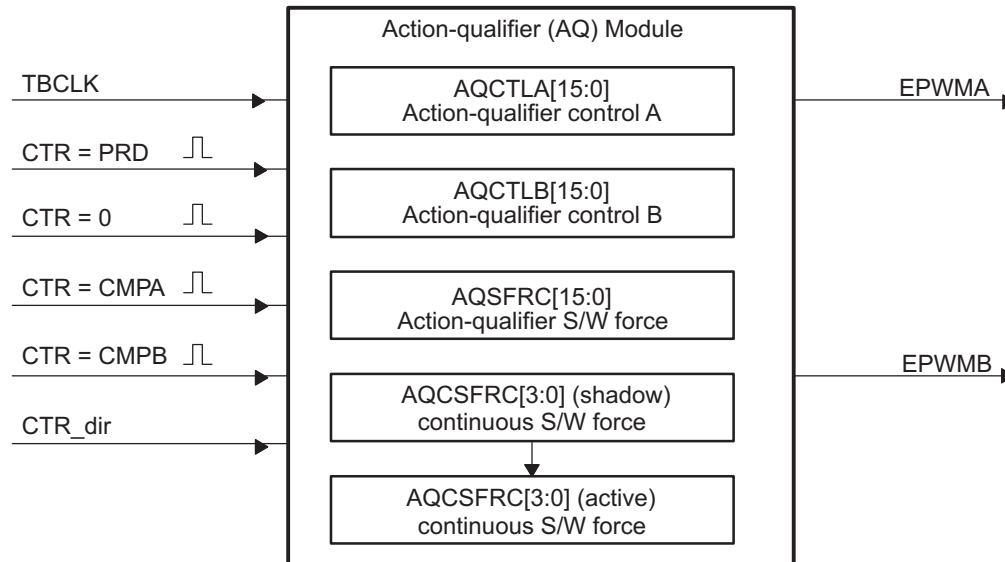

Table 8. Action-Qualifier Submodule Possible Input Events

Signal	Description	Registers Compared
CTR = PRD	Time-base counter equal to the period value	TBCNT = TBPRD
CTR = 0	Time-base counter equal to zero	TBCNT = 0000h
CTR = CMPA	Time-base counter equal to the counter-compare A	TBCNT = CMPA
CTR = CMPB	Time-base counter equal to the counter-compare B	TBCNT = CMPB
Software forced event	Asynchronous event initiated by software	

The software forced action is a useful asynchronous event. This control is handled by registers AQSFR and AQCSFR.

The action-qualifier submodule controls how the two outputs EPWMxA and EPWMxB behave when a particular event occurs. The event inputs to the action-qualifier submodule are further qualified by the counter direction (up or down). This allows for independent action on outputs on both the count-up and count-down phases.





















The possible actions imposed on outputs EPWMxA and EPWMxB are:

- **Set High:** Set output EPWMxA or EPWMxB to a high level.
- **Clear Low:** Set output EPWMxA or EPWMxB to a low level.
- **Toggle:** If EPWMxA or EPWMxB is currently pulled high, then pull the output low. If EPWMxA or EPWMxB is currently pulled low, then pull the output high.
- **Do Nothing:** Keep outputs EPWMxA and EPWMxB at same level as currently set. Although the "Do Nothing" option prevents an event from causing an action on the EPWMxA and EPWMxB outputs, this event can still trigger interrupts. See the event-trigger submodule description in [Section 2.9](#) for details.

Actions are specified independently for either output (EPWMxA or EPWMxB). Any or all events can be configured to generate actions on a given output. For example, both CTR = CMPA and CTR = CMPB can operate on output EPWMxA. All qualifier actions are configured via the control registers found at the end of this section.

For clarity, the drawings in this document use a set of symbolic actions. These symbols are summarized in [Figure 20](#). Each symbol represents an action as a marker in time. Some actions are fixed in time (zero and period) while the CMPA and CMPB actions are moveable and their time positions are programmed via the counter-compare A and B registers, respectively. To turn off or disable an action, use the "Do Nothing option"; it is the default at reset.

Figure 20. Possible Action-Qualifier Actions for EPWMxA and EPWMxB Outputs

S/W force	TB Counter equals:				Actions
	Zero	Comp A	Comp B	Period	
					Do Nothing
					Clear Low
					Set High
					Toggle

2.5.3 Action-Qualifier Event Priority

It is possible for the ePWM action qualifier to receive more than one event at the same time. In this case events are assigned a priority by the hardware. The general rule is events occurring later in time have a higher priority and software forced events always have the highest priority. The event priority levels for up-down-count mode are shown in [Table 9](#). A priority level of 1 is the highest priority and level 7 is the lowest. The priority changes slightly depending on the direction of TBCNT.

Table 9. Action-Qualifier Event Priority for Up-Down-Count Mode

Priority Level	Event if TBCNT is Incrementing TBCNT = 0 up to TBCNT = TBPRD	Event if TBCNT is Decrementing TBCNT = TBPRD down to TBCNT = 1
1 (Highest)	Software forced event	Software forced event
2	Counter equals CMPB on up-count (CBU)	Counter equals CMPB on down-count (CBD)
3	Counter equals CMPA on up-count (CAU)	Counter equals CMPA on down-count (CAD)
4	Counter equals zero	Counter equals period (TBPRD)
5	Counter equals CMPB on down-count (CBD) ⁽¹⁾	Counter equals CMPB on up-count (CBU) ⁽¹⁾
6 (Lowest)	Counter equals CMPA on down-count (CAD) ⁽¹⁾	Counter equals CMPA on up-count (CBU) ⁽¹⁾

⁽¹⁾ To maintain symmetry for up-down-count mode, both up-events (CAU/CBU) and down-events (CAD/CBD) can be generated for TBPRD. Otherwise, up-events can occur only when the counter is incrementing and down-events can occur only when the counter is decrementing.

[Table 10](#) shows the action-qualifier priority for up-count mode. In this case, the counter direction is always defined as up and thus down-count events will never be taken.

Table 10. Action-Qualifier Event Priority for Up-Count Mode

Priority Level	Event
1 (Highest)	Software forced event
2	Counter equal to period (TBPRD)
3	Counter equal to CMPB on up-count (CBU)
4	Counter equal to CMPA on up-count (CAU)
5 (Lowest)	Counter equal to Zero

[Table 11](#) shows the action-qualifier priority for down-count mode. In this case, the counter direction is always defined as down and thus up-count events will never be taken.

Table 11. Action-Qualifier Event Priority for Down-Count Mode

Priority Level	Event
1 (Highest)	Software forced event
2	Counter equal to Zero
3	Counter equal to CMPB on down-count (CBD)
4	Counter equal to CMPA on down-count (CAD)
5 (Lowest)	Counter equal to period (TBPRD)

It is possible to set the compare value greater than the period. In this case the action will take place as shown in [Table 12](#).

Table 12. Behavior if CMPA/CMPB is Greater than the Period

Counter Mode	Compare on Up-Count Event CAU/CBU	Compare on Down-Count Event CAU/CBU
Up-Count Mode	If $CMPA/CMPB \leq TBPRD$ period, then the event occurs on a compare match ($TBCNT = CMPA$ or $CMPB$). If $CMPA/CMPB > TBPRD$, then the event will not occur.	Never occurs.
Down-Count Mode	Never occurs.	If $CMPA/CMPB < TBPRD$, the event will occur on a compare match ($TBCNT = CMPA$ or $CMPB$). If $CMPA/CMPB \geq TBPRD$, the event will occur on a period match ($TBCNT = TBPRD$).
Up-Down-Count Mode	If $CMPA/CMPB < TBPRD$ and the counter is incrementing, the event occurs on a compare match ($TBCNT = CMPA$ or $CMPB$). If $CMPA/CMPB \geq TBPRD$, the event will occur on a period match ($TBCNT = TBPRD$).	If $CMPA/CMPB < TBPRD$ and the counter is decrementing, the event occurs on a compare match ($TBCNT = CMPA$ or $CMPB$). If $CMPA/CMPB \geq TBPRD$, the event occurs on a period match ($TBCNT = TBPRD$).

2.5.4 Waveforms for Common Configurations

NOTE: The waveforms in this document show the ePWMs behavior for a static compare register value. In a running system, the active compare registers (CMPA and CMPB) are typically updated from their respective shadow registers once every period. The user specifies when the update will take place; either when the time-base counter reaches zero or when the time-base counter reaches period. There are some cases when the action based on the new value can be delayed by one period or the action based on the old value can take effect for an extra period. Some PWM configurations avoid this situation. These include, but are not limited to, the following:

Use up-down-count mode to generate a symmetric PWM:

- If you load CMPA/CMPB on zero, then use CMPA/CMPB values greater than or equal to 1.
- If you load CMPA/CMPB on period, then use CMPA/CMPB values less than or equal to $TBPRD - 1$.

This means there will always be a pulse of at least one TBCLK cycle in a PWM period which, when very short, tend to be ignored by the system.

Use up-down-count mode to generate an asymmetric PWM:

- To achieve 50%-0% asymmetric PWM use the following configuration: Load CMPA/CMPB on period and use the period action to clear the PWM and a compare-up action to set the PWM. Modulate the compare value from 0 to TBPRD to achieve 50%-0% PWM duty.

When using up-count mode to generate an asymmetric PWM:

- To achieve 0-100% asymmetric PWM use the following configuration: Load CMPA/CMPB on TBPRD. Use the Zero action to set the PWM and a compare-up action to clear the PWM. Modulate the compare value from 0 to $TBPRD+1$ to achieve 0-100% PWM duty.

Figure 21 shows how a symmetric PWM waveform can be generated using the up-down-count mode of the TBCNT. In this mode 0%-100% DC modulation is achieved by using equal compare matches on the up count and down count portions of the waveform. In the example shown, CMPA is used to make the comparison. When the counter is incrementing the CMPA match will pull the PWM output high. Likewise, when the counter is decrementing the compare match will pull the PWM signal low. When $CMPA = 0$, the PWM signal is low for the entire period giving the 0% duty waveform. When $CMPA = TBPRD$, the PWM signal is high achieving 100% duty.

When using this configuration in practice, if you load $CMPA/CMPB$ on zero, then use $CMPA/CMPB$ values greater than or equal to 1. If you load $CMPA/CMPB$ on period, then use $CMPA/CMPB$ values less than or equal to $TBPRD-1$. This means there will always be a pulse of at least one $TBCLK$ cycle in a PWM period which, when very short, tend to be ignored by the system.

Figure 21. Up-Down-Count Mode Symmetrical Waveform

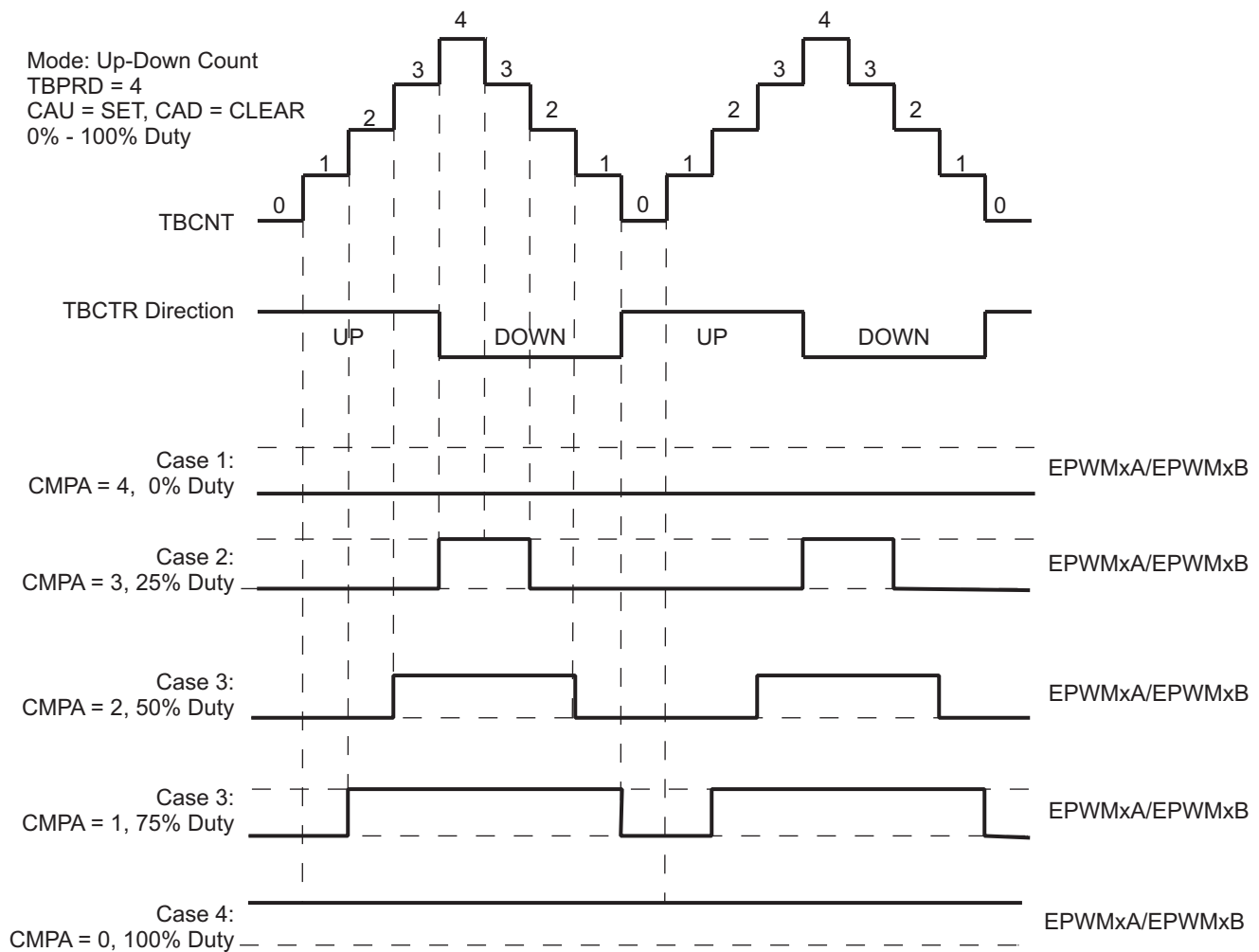

The PWM waveforms in [Figure 22](#) through [Figure 27](#) show some common action-qualifier configurations. Some conventions used in the figures are as follows:

- TBPRD, CMPA, and CMPB refer to the value written in their respective registers. The active register, not the shadow register, is used by the hardware.
- CMPx, refers to either CMPA or CMPB.
- EPWMxA and EPWMxB refer to the output signals from ePWMx
- Up-Down means Count-up-and-down mode, Up means up-count mode and Dwn means down-count mode
- Sym = Symmetric, Asym = Asymmetric

[Table 13](#) and [Table 14](#) contains initialization and runtime register configurations for the waveforms in [Figure 22](#).

Figure 22. Up, Single Edge Asymmetric Waveform, With Independent Modulation on EPWMxA and EPWMxB—Active High

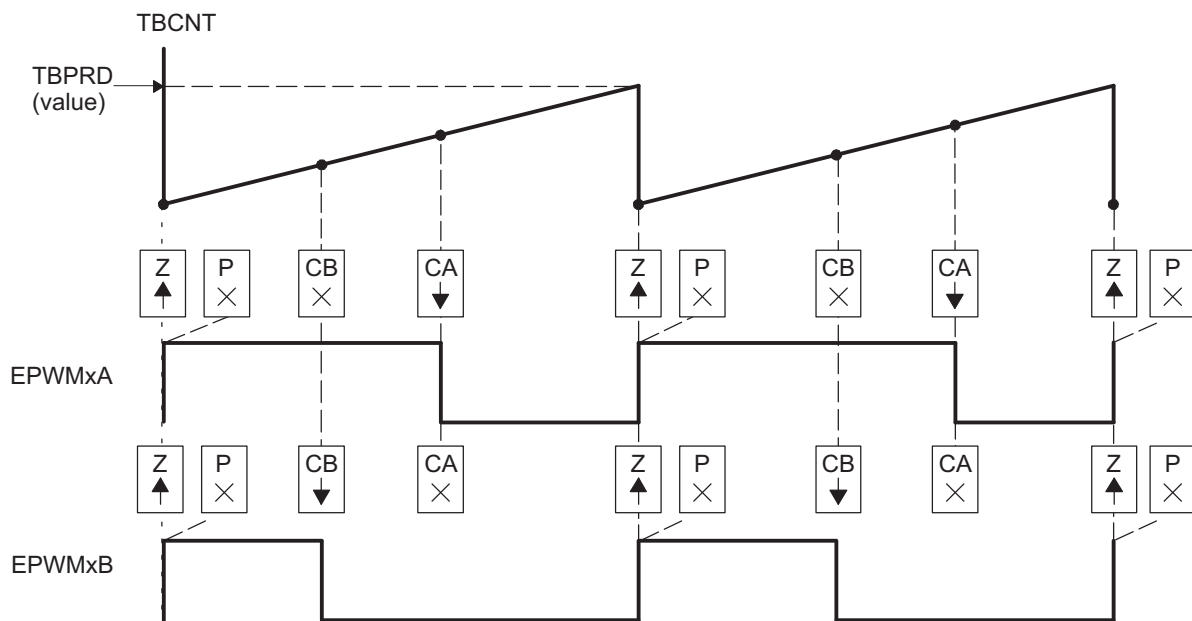

- (1) $PWM\ period = (TBPRD + 1) \times T_{TBCLK}$
- (2) Duty modulation for EPWMxA is set by CMPA, and is active high (that is, high time duty proportional to CMPA).
- (3) Duty modulation for EPWMxB is set by CMPB and is active high (that is, high time duty proportional to CMPB).
- (4) The "Do Nothing" actions (X) are shown for completeness, but will not be shown on subsequent diagrams.
- (5) Actions at zero and period, although appearing to occur concurrently, are actually separated by one TBCLK period. TBCNT wraps from period to 0000h.

Table 13. EPWMx Initialization for Figure 22

Register	Bit	Value	Comments
TBPRD	TBPRD	600 (258h)	Period = 601 TBCLK counts
TBPHS	TBPHS	0	Clear Phase Register to 0
TBCNT	TBCNT	0	Clear TB counter
TBCTL	CTRMODE	TB_UP	
	PHSEN	TB_DISABLE	Phase loading disabled
	PRDL	TB_SHADOW	
	SYNCOSEL	TB_SYNC_DISABLE	
	HSPCLKDIV	TB_DIV1	TBCLK = SYSCLK
	CLKDIV	TB_DIV1	
CMPA	CMPA	350 (15Eh)	Compare A = 350 TBCLK counts
CMPB	CMPB	200 (C8h)	Compare B = 200 TBCLK counts
CMPCTL	SHDWAMODE	CC_SHADOW	
	SHDWBMODE	CC_SHADOW	
	LOADAMODE	CC_CTR_ZERO	Load on CTR = 0
	LOADBMODE	CC_CTR_ZERO	Load on CTR = 0
AQCTLA	ZRO	AQ_SET	
	CAU	AQ_CLEAR	
AQCTLB	ZRO	AQ_SET	
	CBU	AQ_CLEAR	

Table 14. EPWMx Run Time Changes for Figure 22

Register	Bit	Value	Comments
CMPA	CMPA	Duty1A	Adjust duty for output EPWM1A
CMPB	CMPB	Duty1B	Adjust duty for output EPWM1B

Table 15 and Table 16 contains initialization and runtime register configurations for the waveforms in Figure 23.

Figure 23. Up, Single Edge Asymmetric Waveform With Independent Modulation on EPWMxA and EPWMxB—Active Low

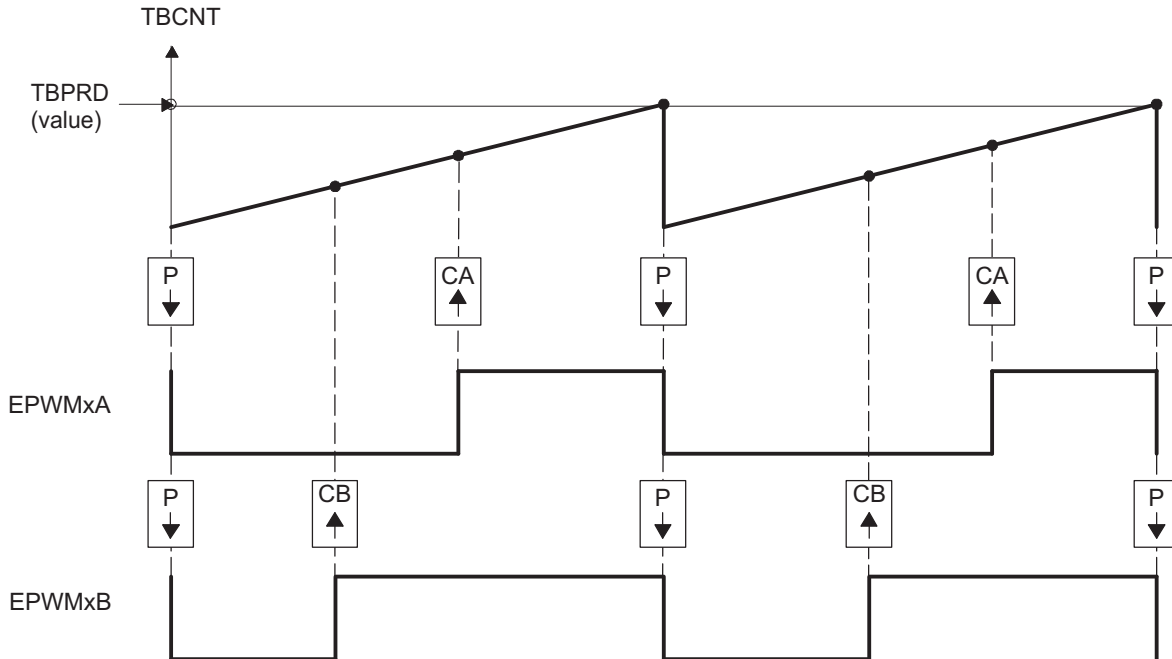

- (1) $PWM\ period = (TBPRD + 1) \times T_{TBCLK}$
- (2) Duty modulation for EPWMxA is set by CMPA, and is active low (that is, the low time duty is proportional to CMPA).
- (3) Duty modulation for EPWMxB is set by CMPB and is active low (that is, the low time duty is proportional to CMPB).
- (4) The Do Nothing actions (X) are shown for completeness here, but will not be shown on subsequent diagrams.
- (5) Actions at zero and period, although appearing to occur concurrently, are actually separated by one TBCLK period. TBCNT wraps from period to 0000h.

Table 15. EPWMx Initialization for Figure 23

Register	Bit	Value	Comments
TBPRD	TBPRD	600 (258h)	Period = 601 TBCLK counts
TBPHS	TBPHS	0	Clear Phase Register to 0
TBCNT	TBCNT	0	Clear TB counter
TBCTL	CTRMODE	TB_UP	
	PHSEN	TB_DISABLE	Phase loading disabled
	PRDL	TB_SHADOW	
	SYNCOSEL	TB_SYNC_DISABLE	
	HSPCLKDIV	TB_DIV1	TBCLK = SYSCLK
	CLKDIV	TB_DIV1	
CMPA	CMPA	350 (15Eh)	Compare A = 350 TBCLK counts
CMPB	CMPB	200 (C8h)	Compare B = 200 TBCLK counts
CMPCTL	SHDWAMODE	CC_SHADOW	
	SHDWBMODE	CC_SHADOW	
	LOADAMODE	CC_CTR_ZERO	Load on CTR = 0
	LOADBMODE	CC_CTR_ZERO	Load on CTR = 0
AQCTLA	PRD	AQ_CLEAR	
	CAU	AQ_SET	
AQCTLB	PRD	AQ_CLEAR	
	CBU	AQ_SET	

Table 16. EPWMx Run Time Changes for Figure 23

Register	Bit	Value	Comments
CMPA	CMPA	Duty1A	Adjust duty for output EPWM1A
CMPB	CMPB	Duty1B	Adjust duty for output EPWM1B

Table 17 and Table 18 contains initialization and runtime register configurations for the waveforms Figure 24. Use the code in Example 1 to define the headers.

Figure 24. Up-Count, Pulse Placement Asymmetric Waveform With Independent Modulation on EPWMxA

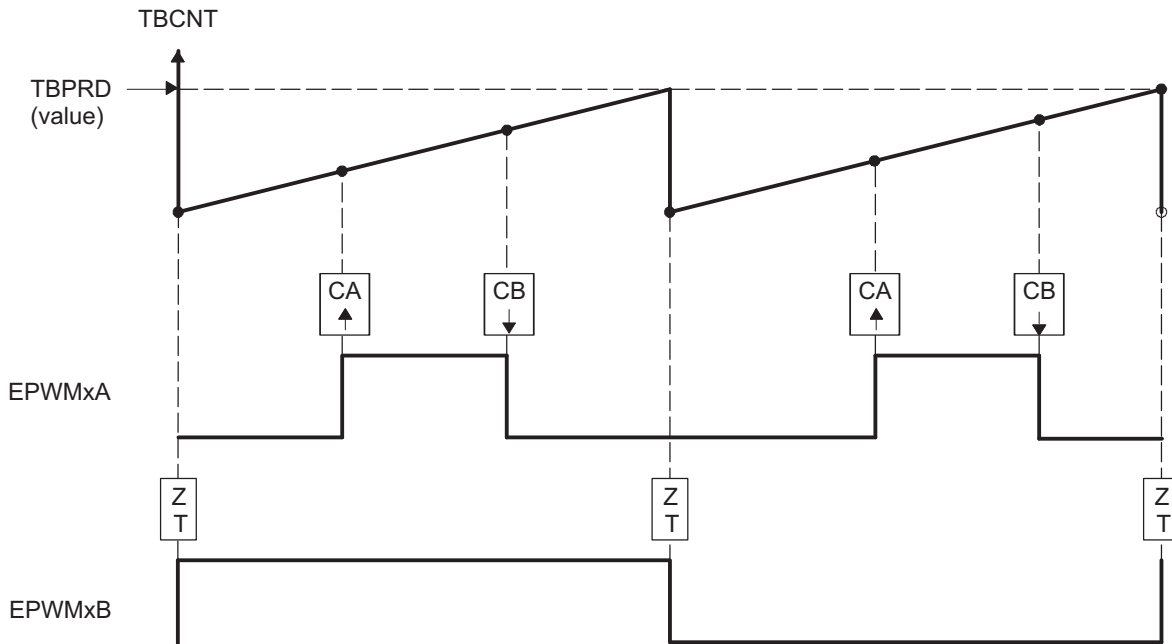

- (1) $\text{PWM frequency} = 1 / ((\text{TBPRD} + 1) \times T_{\text{TBCLK}})$
- (2) Pulse can be placed anywhere within the PWM cycle ($0000h - \text{TBPRD}$)
- (3) High time duty proportional to $(\text{CMPB} - \text{CMPA})$
- (4) EPWMxB can be used to generate a 50% duty square wave with frequency $= 1/2 \times ((\text{TBPRD} + 1) \times \text{TBCLK})$

Table 17. EPWMx Initialization for Figure 24

Register	Bit	Value	Comments
TBPRD	TBPRD	600 (258h)	Period = 601 TBCLK counts
TBPHS	TBPHS	0	Clear Phase Register to 0
TBCNT	TBCNT	0	Clear TB counter
TBCTL	CTRMODE	TB_UP	
	PHSEN	TB_DISABLE	Phase loading disabled
	PRDL	TB_SHADOW	
	SYNCOSEL	TB_SYNC_DISABLE	
	HSPCLKDIV	TB_DIV1	TBCLK = SYSCLK
	CLKDIV	TB_DIV1	
CMPA	CMPA	200 (C8h)	Compare A = 200 TBCLK counts
CMPB	CMPB	400 (190h)	Compare B = 400 TBCLK counts
CMPCTL	SHDWAMODE	CC_SHADOW	
	SHDWBMODE	CC_SHADOW	
	LOADAMODE	CC_CTR_ZERO	Load on CTR = 0
	LOADBMODE	CC_CTR_ZERO	Load on CTR = 0
AQCTLA	CAU	AQ_SET	
	CBU	AQ_CLEAR	
AQCTLB	ZRO	AQ_TOGGLE	

Table 18. EPWMx Run Time Changes for Figure 24

Register	Bit	Value	Comments
CMPA	CMPA	EdgePosA	Adjust duty for output EPWM1A
CMPB	CMPB	EdgePosB	

Table 19 and Table 20 contains initialization and runtime register configurations for the waveforms in Figure 25. Use the code in Example 1 to define the headers.

Figure 25. Up-Down-Count, Dual Edge Symmetric Waveform, With Independent Modulation on EPWMxA and EPWMxB — Active Low

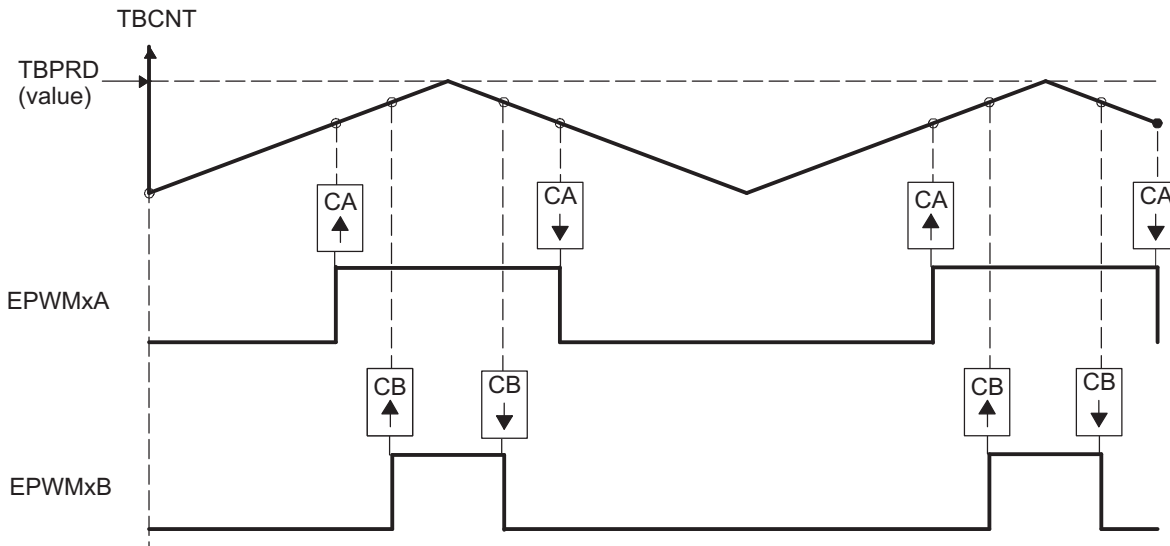

- (1) $PWM\ period = 2 \times TBPRD \times T_{TBCLK}$
- (2) Duty modulation for EPWMxA is set by CMPA, and is active low (that is, the low time duty is proportional to CMPA).
- (3) Duty modulation for EPWMxB is set by CMPB and is active low (that is, the low time duty is proportional to CMPB).
- (4) Outputs EPWMxA and EPWMxB can drive independent power switches

Table 19. EPWMx Initialization for Figure 25

Register	Bit	Value	Comments
TBPRD	TBPRD	600 (258h)	Period = 601 TBCLK counts
TBPHS	TBPHS	0	Clear Phase Register to 0
TBCNT	TBCNT	0	Clear TB counter
TBCTL	CTRMODE	TB_UPDOWN	
	PHSEN	TB_DISABLE	Phase loading disabled
	PRDL	TB_SHADOW	
	SYNCOSEL	TB_SYNC_DISABLE	
	HSPCLKDIV	TB_DIV1	TBCLK = SYSCLK
	CLKDIV	TB_DIV1	
CMPA	CMPA	400 (190h)	Compare A = 400 TBCLK counts
CMPB	CMPB	500 (1F4h)	Compare B = 500 TBCLK counts
CMPCTL	SHDWAMODE	CC_SHADOW	
	SHDWBMODE	CC_SHADOW	
	LOADAMODE	CC_CTR_ZERO	Load on CTR = 0
	LOADBMODE	CC_CTR_ZERO	Load on CTR = 0
AQCTLA	CAU	AQ_SET	
	CAD	AQ_CLEAR	
AQCTLB	CBU	AQ_SET	
	CBD	AQ_CLEAR	

Table 20. EPWMx Run Time Changes for Figure 25

Register	Bit	Value	Comments
CMPA	CMPA	Duty1A	Adjust duty for output EPWM1A
CMPB	CMPB	Duty1B	Adjust duty for output EPWM1B

Table 21 and Table 22 contains initialization and runtime register configurations for the waveforms in Figure 26. Use the code in Example 1 to define the headers.

Figure 26. Up-Down-Count, Dual Edge Symmetric Waveform, With Independent Modulation on EPWMxA and EPWMxB — Complementary

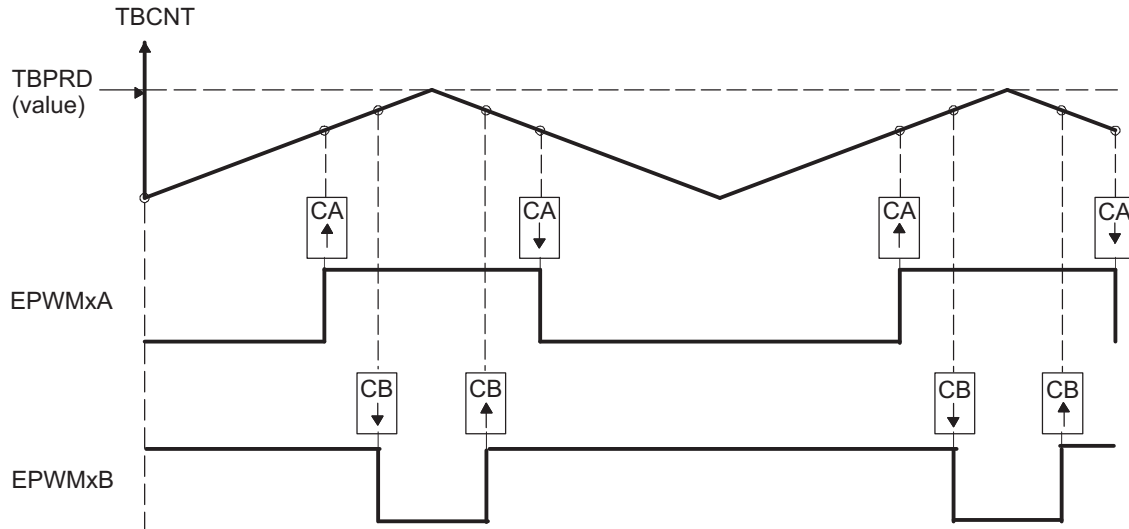

- (1) $PWM\ period = 2 \times TBPRD \times T_{TBCLK}$
- (2) Duty modulation for EPWMxA is set by CMPA, and is active low, i.e., low time duty proportional to CMPA
- (3) Duty modulation for EPWMxB is set by CMPB and is active high, i.e., high time duty proportional to CMPB
- (4) Outputs EPWMx can drive upper/lower (complementary) power switches
- (5) Dead-band = $CMPB - CMPA$ (fully programmable edge placement by software). Note the dead-band module is also available if the more classical edge delay method is required.

Table 21. EPWMx Initialization for Figure 26

Register	Bit	Value	Comments
TBPRD	TBPRD	600 (258h)	Period = 601 TBCLK counts
TBPHS	TBPHS	0	Clear Phase Register to 0
TBCNT	TBCNT	0	Clear TB counter
TBCTL	CTRMODE	TB_UPDOWN	
	PHSEN	TB_DISABLE	Phase loading disabled
	PRDL	TB_SHADOW	
	SYNCOSEL	TB_SYNC_DISABLE	
	HSPCLKDIV	TB_DIV1	TBCLK = SYSCLK
	CLKDIV	TB_DIV1	
CMPA	CMPA	350 (15Eh)	Compare A = 350 TBCLK counts
CMPB	CMPB	400 (190h)	Compare B = 400 TBCLK counts
CMPCTL	SHDWAMODE	CC_SHADOW	
	SHDWBMODE	CC_SHADOW	
	LOADAMODE	CC_CTR_ZERO	Load on CTR = 0
	LOADBMODE	CC_CTR_ZERO	Load on CTR = 0
AQCTLA	CAU	AQ_SET	
	CAD	AQ_CLEAR	
AQCTLB	CBU	AQ_CLEAR	
	CBD	AQ_SET	

Table 22. EPWMx Run Time Changes for Figure 26

Register	Bit	Value	Comments
CMPA	CMPA	Duty1A	Adjust duty for output EPWM1A
CMPB	CMPB	Duty1B	Adjust duty for output EPWM1B

Table 23 and Table 24 contains initialization and runtime register configurations for the waveforms in Figure 27. Use the code in Example 1 to define the headers.

Figure 27. Up-Down-Count, Dual Edge Asymmetric Waveform, With Independent Modulation on EPWMxA—Active Low

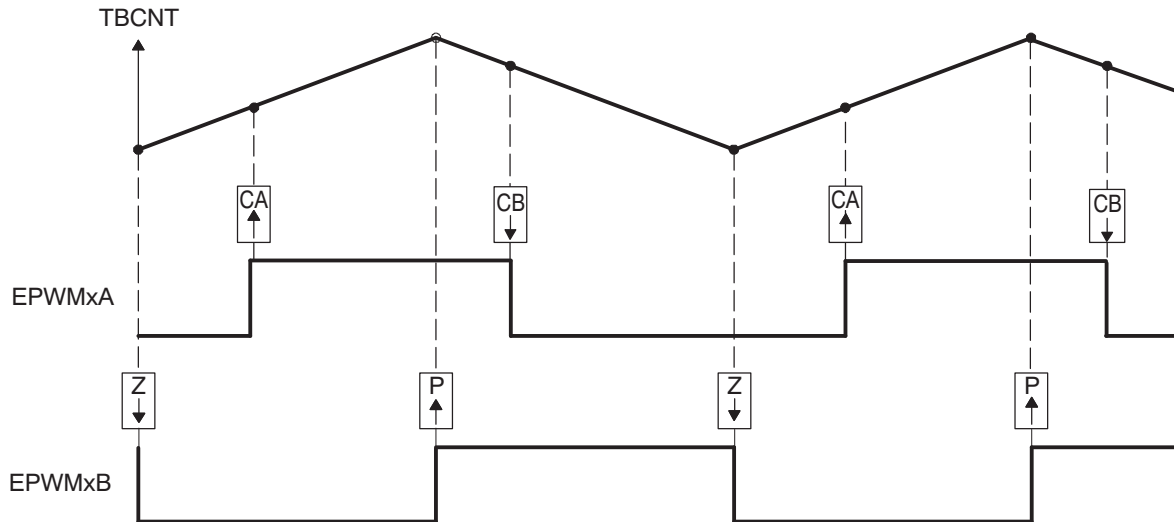

- (1) PWM period = $2 \times \text{TBPRD} \times \text{TBCLK}$
- (2) Rising edge and falling edge can be asymmetrically positioned within a PWM cycle. This allows for pulse placement techniques.
- (3) Duty modulation for EPWMxA is set by CMPA and CMPB.
- (4) Low time duty for EPWMxA is proportional to (CMPA + CMPB).
- (5) To change this example to active high, CMPA and CMPB actions need to be inverted (i.e., Set ! Clear and Clear Set).
- (6) Duty modulation for EPWMxB is fixed at 50% (utilizes spare action resources for EPWMxB)

Table 23. EPWMx Initialization for Figure 27

Register	Bit	Value	Comments
TBPRD	TBPRD	600 (258h)	Period = 601 TBCLK counts
TBPHS	TBPHS	0	Clear Phase Register to 0
TBCNT	TBCNT	0	Clear TB counter
TBCTL	CTRMODE	TB_UPDOWN	
	PHSEN	TB_DISABLE	Phase loading disabled
	PRDL	TB_SHADOW	
	SYNCOSEL	TB_SYNC_DISABLE	
	HSPCLKDIV	TB_DIV1	TBCLK = SYSCLK
	CLKDIV	TB_DIV1	
CMPA	CMPA	250 (FAh)	Compare A = 250 TBCLK counts
CMPB	CMPB	450 (1C2h)	Compare B = 450 TBCLK counts
CMPCTL	SHDWAMODE	CC_SHADOW	
	SHDWBMODE	CC_SHADOW	
	LOADAMODE	CC_CTR_ZERO	Load on CTR = 0
	LOADBMODE	CC_CTR_ZERO	Load on CTR = 0
AQCTLA	CAU	AQ_SET	
	CBD	AQ_CLEAR	
AQCTLB	ZRO	AQ_CLEAR	
	PRD	AQ_SET	

Table 24. EPWMx Run Time Changes for Figure 27

Register	Bit	Value	Comments
CMPA	CMPA	EdgePosA	Adjust duty for output EPWM1A
CMPB	CMPB	EdgePosB	

2.6 Dead-Band Generator (DB) Submodule

Figure 28 illustrates the dead-band generator submodule within the ePWM module.

Figure 28. Dead-Band Generator Submodule

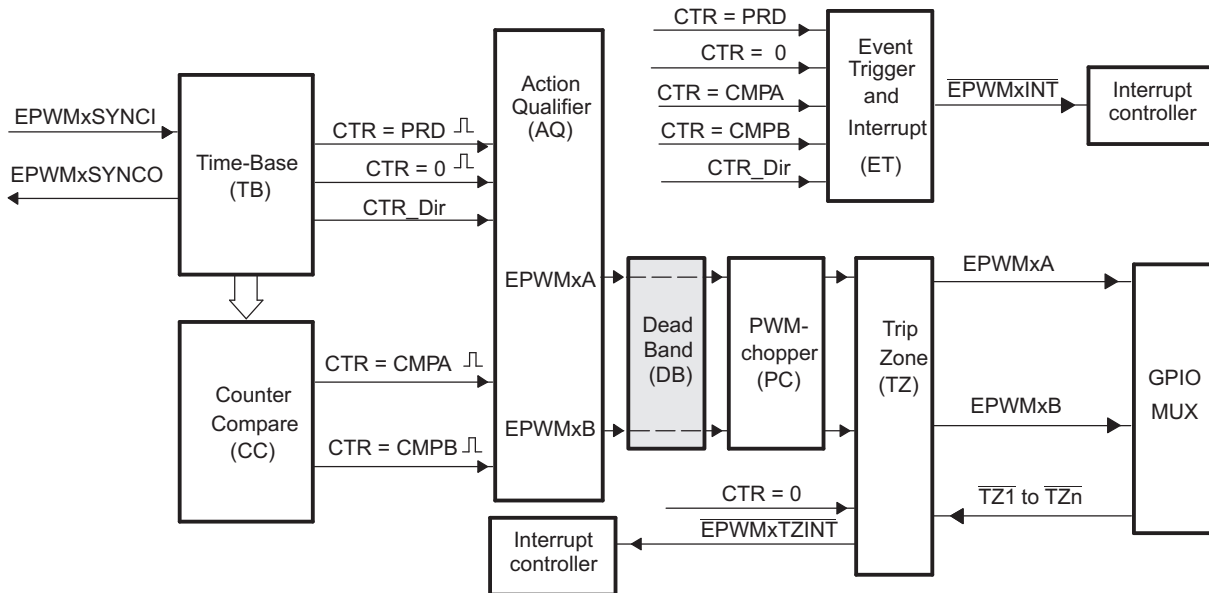

2.6.1 Purpose of the Dead-Band Submodule

The "Action-qualifier (AQ) Module" section discussed how it is possible to generate the required dead-band by having full control over edge placement using both the CMPA and CMPB resources of the ePWM module. However, if the more classical edge delay-based dead-band with polarity control is required, then the dead-band generator submodule should be used.

The key functions of the dead-band generator submodule are:

- Generating appropriate signal pairs (EPWMxA and EPWMxB) with dead-band relationship from a single EPWMxA input
- Programming signal pairs for:
 - Active high (AH)
 - Active low (AL)
 - Active high complementary (AHC)
 - Active low complementary (ALC)
- Adding programmable delay to rising edges (RED)
- Adding programmable delay to falling edges (FED)
- Can be totally bypassed from the signal path (note dotted lines in diagram)

2.6.2 Controlling and Monitoring the Dead-Band Submodule

The dead-band generator submodule operation is controlled and monitored via the following registers:

Table 25. Dead-Band Generator Submodule Registers

Acronym	Register Description	Address Offset	Shadowed
DBCTL	Dead-Band Control Register	1Eh	No
DBRED	Dead-Band Rising Edge Delay Count Register	20h	No
DBFED	Dead-Band Falling Edge Delay Count Register	22h	No

2.6.3 Operational Highlights for the Dead-Band Generator Submodule

The following sections provide the operational highlights.

The dead-band submodule has two groups of independent selection options as shown in [Figure 29](#).

- Input Source Selection:** The input signals to the dead-band module are the EPWMxA and EPWMxB output signals from the action-qualifier. In this section they will be referred to as EPWMxA In and EPWMxB In. Using the DBCTL[IN_MODE] control bits, the signal source for each delay, falling-edge or rising-edge, can be selected:
 - EPWMxA In is the source for both falling-edge and rising-edge delay. This is the default mode.
 - EPWMxA In is the source for falling-edge delay, EPWMxB In is the source for rising-edge delay.
 - EPWMxA In is the source for rising edge delay, EPWMxB In is the source for falling-edge delay.
 - EPWMxB In is the source for both falling-edge and rising-edge delay.
- Output Mode Control:** The output mode is configured by way of the DBCTL[OUT_MODE] bits. These bits determine if the falling-edge delay, rising-edge delay, neither, or both are applied to the input signals.
- Polarity Control:** The polarity control (DBCTL[POLSEL]) allows you to specify whether the rising-edge delayed signal and/or the falling-edge delayed signal is to be inverted before being sent out of the dead-band submodule.

Figure 29. Configuration Options for the Dead-Band Generator Submodule

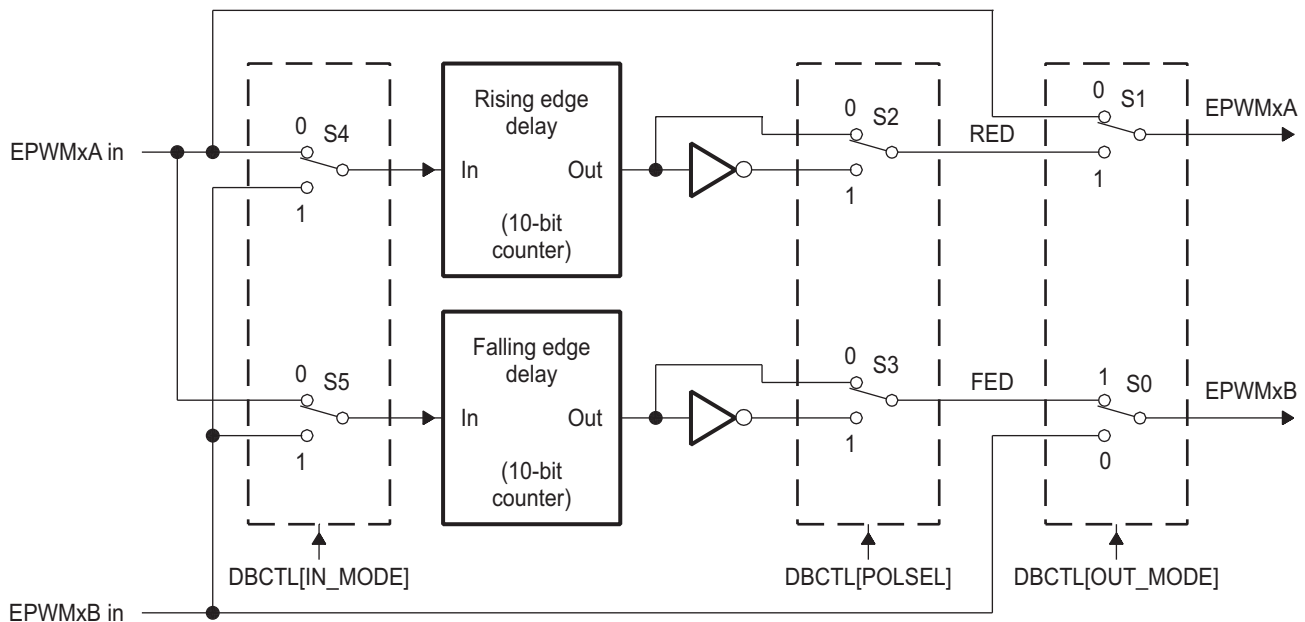

Although all combinations are supported, not all are typical usage modes. [Table 26](#) documents some classical dead-band configurations. These modes assume that the DBCTL[IN_MODE] is configured such that EPWMxA In is the source for both falling-edge and rising-edge delay. Enhanced, or non-traditional modes can be achieved by changing the input signal source. The modes shown in [Table 26](#) fall into the following categories:

- **Mode 1: Bypass both falling-edge delay (FED) and rising-edge delay (RED)** Allows you to fully disable the dead-band submodule from the PWM signal path.
- **Mode 2-5: Classical Dead-Band Polarity Settings** These represent typical polarity configurations that should address all the active high/low modes required by available industry power switch gate drivers. The waveforms for these typical cases are shown in [Figure 30](#). Note that to generate equivalent waveforms to [Figure 30](#), configure the action-qualifier submodule to generate the signal as shown for EPWMxA.
- **Mode 6: Bypass rising-edge-delay and Mode 7: Bypass falling-edge-delay** Finally the last two entries in [Table 26](#) show combinations where either the falling-edge-delay (FED) or rising-edge-delay (RED) blocks are bypassed.

Table 26. Classical Dead-Band Operating Modes

Mode	Mode Description ⁽¹⁾	DBCTL[POLSEL]		DBCTL[OUT_MODE]	
		S3	S2	S1	S0
1	EPWMxA and EPWMxB Passed Through (No Delay)	x	x	0	0
2	Active High Complementary (AHC)	1	0	1	1
3	Active Low Complementary (ALC)	0	1	1	1
4	Active High (AH)	0	0	1	1
5	Active Low (AL)	1	1	1	1
6	EPWMxA Out = EPWMxA In (No Delay) EPWMxB Out = EPWMxA In with Falling Edge Delay	0 or 1	0 or 1	0	1
7	EPWMxA Out = EPWMxA In with Rising Edge Delay EPWMxB Out = EPWMxB In with No Delay	0 or 1	0 or 1	1	0

⁽¹⁾ These are classical dead-band modes and assume that DBCTL[IN_MODE] = 0,0. That is, EPWMxA in is the source for both the falling-edge and rising-edge delays. Enhanced, non-traditional modes can be achieved by changing the IN_MODE configuration.

Figure 30 shows waveforms for typical cases where $0\% < \text{duty} < 100\%$.

Figure 30. Dead-Band Waveforms for Typical Cases ($0\% < \text{Duty} < 100\%$)

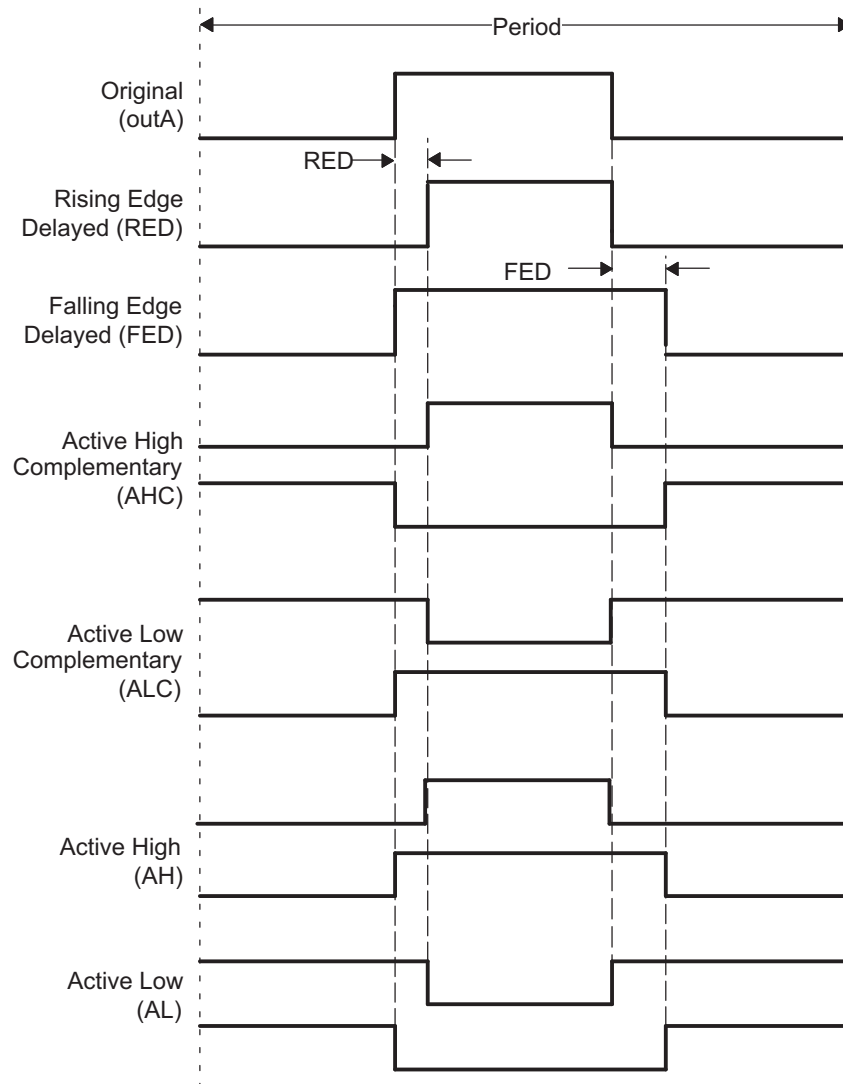

The dead-band submodule supports independent values for rising-edge (RED) and falling-edge (FED) delays. The amount of delay is programmed using the DBRED and DBFED registers. These are 10-bit registers and their value represents the number of time-base clock, TBCLK, periods a signal edge is delayed by. For example, the formula to calculate falling-edge-delay and rising-edge-delay are:

$$\text{FED} = \text{DBFED} \times T_{\text{TBCLK}}$$

$$\text{RED} = \text{DBRED} \times T_{\text{TBCLK}}$$

Where T_{TBCLK} is the period of TBCLK, the prescaled version of SYSCLKOUT.

2.7 PWM-Chopper (PC) Submodule

Figure 31 illustrates the PWM-chopper (PC) submodule within the ePWM module. The PWM-chopper submodule allows a high-frequency carrier signal to modulate the PWM waveform generated by the action-qualifier and dead-band submodules. This capability is important if you need pulse transformer-based gate drivers to control the power switching elements.

Figure 31. PWM-Chopper Submodule

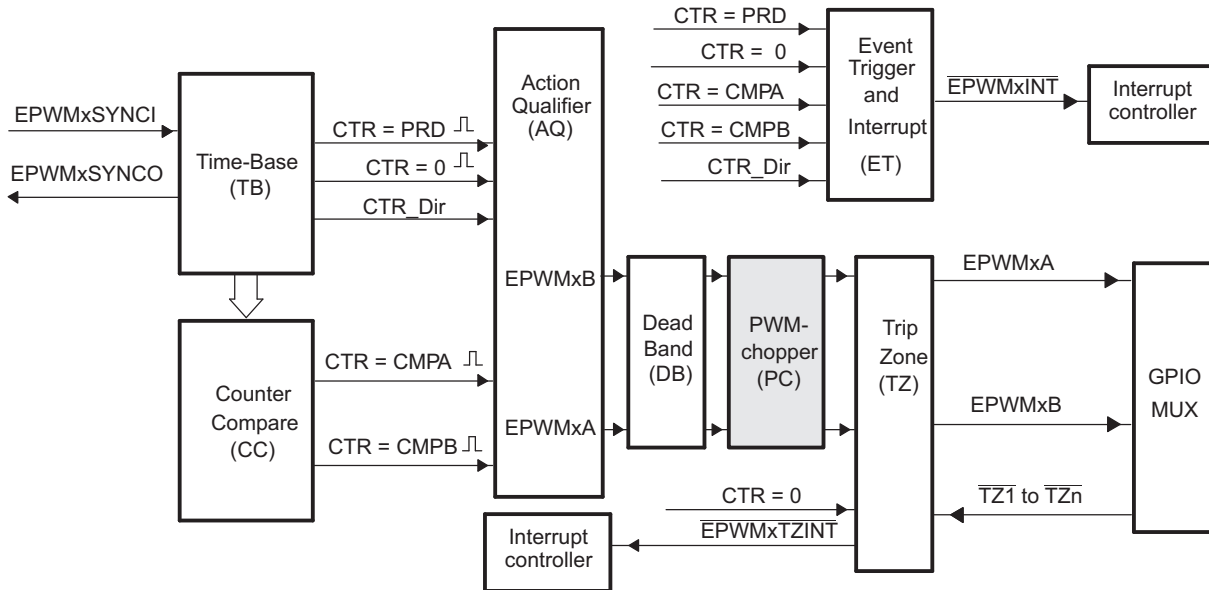

2.7.1 Purpose of the PWM-Chopper Submodule

The key functions of the PWM-chopper submodule are:

- Programmable chopping (carrier) frequency
- Programmable pulse width of first pulse
- Programmable duty cycle of second and subsequent pulses
- Can be fully bypassed if not required

2.7.2 Controlling the PWM-Chopper Submodule

The PWM-chopper submodule operation is controlled via the register in Table 27.

Table 27. PWM-Chopper Submodule Registers

Acronym	Register Description	Address Offset	Shadowed
PCCTL	PWM-chopper Control Register	3Ch	No

2.7.3 Operational Highlights for the PWM-Chopper Submodule

Figure 32 shows the operational details of the PWM-chopper submodule. The carrier clock is derived from SYSCLKOUT. Its frequency and duty cycle are controlled via the CHPFREQ and CHPDUTY bits in the PCCTL register. The one-shot block is a feature that provides a high energy first pulse to ensure hard and fast power switch turn on, while the subsequent pulses sustain pulses, ensuring the power switch remains on. The one-shot width is programmed via the OSHTWTH bits. The PWM-chopper submodule can be fully disabled (bypassed) via the CHPEN bit.

Figure 32. PWM-Chopper Submodule Signals and Registers

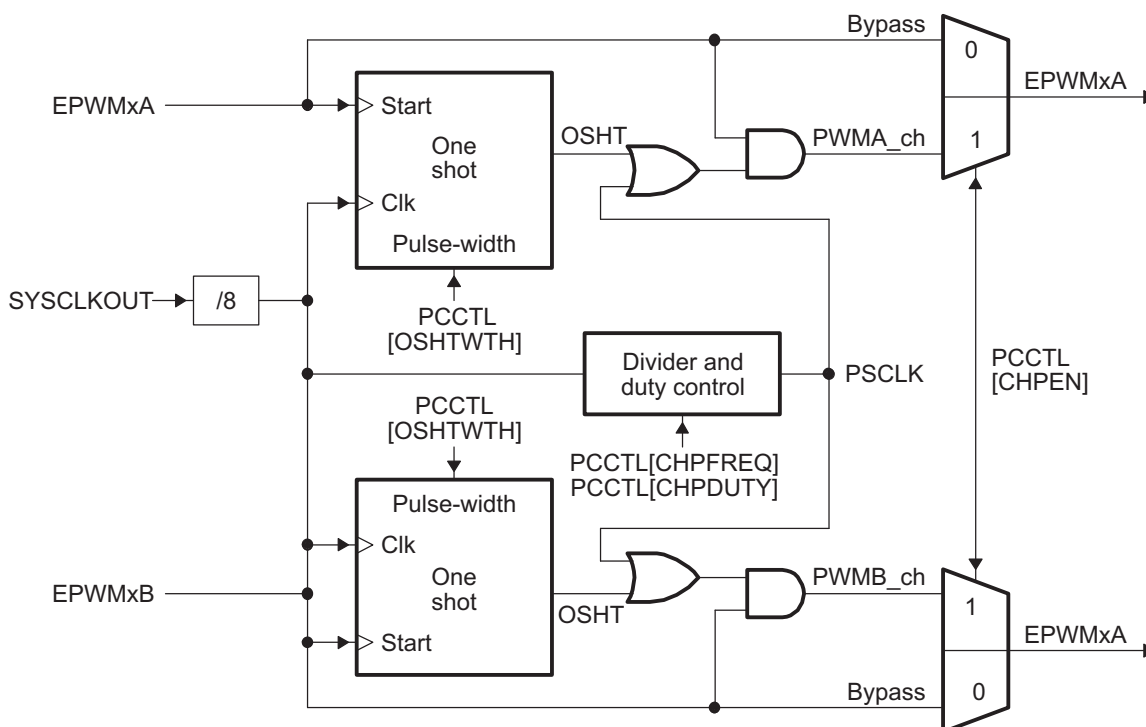

2.7.4 Waveforms

Figure 33 shows simplified waveforms of the chopping action only; one-shot and duty-cycle control are not shown. Details of the one-shot and duty-cycle control are discussed in the following sections.

Figure 33. Simple PWM-Chopper Submodule Waveforms Showing Chopping Action Only

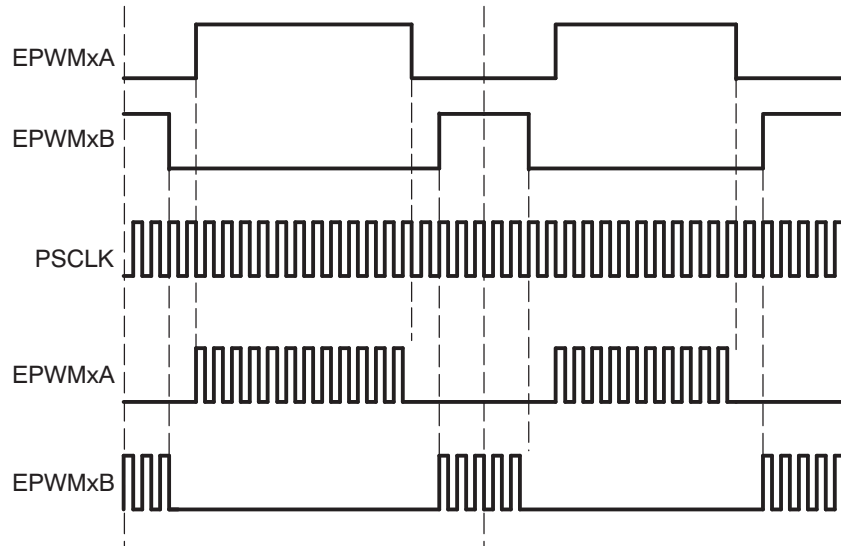

2.7.4.1 One-Shot Pulse

The width of the first pulse can be programmed to any of 16 possible pulse width values. The width or period of the first pulse is given by:

$$T_{1stpulse} = T_{SYSCLKOUT} \times 8 \times OSHTWTH$$

Where $T_{SYSCLKOUT}$ is the period of the system clock (SYSCLKOUT) and OSHTWTH is the four control bits (value from 1 to 16)

Figure 34 shows the first and subsequent sustaining pulses.

Figure 34. PWM-Chopper Submodule Waveforms Showing the First Pulse and Subsequent Sustaining Pulses

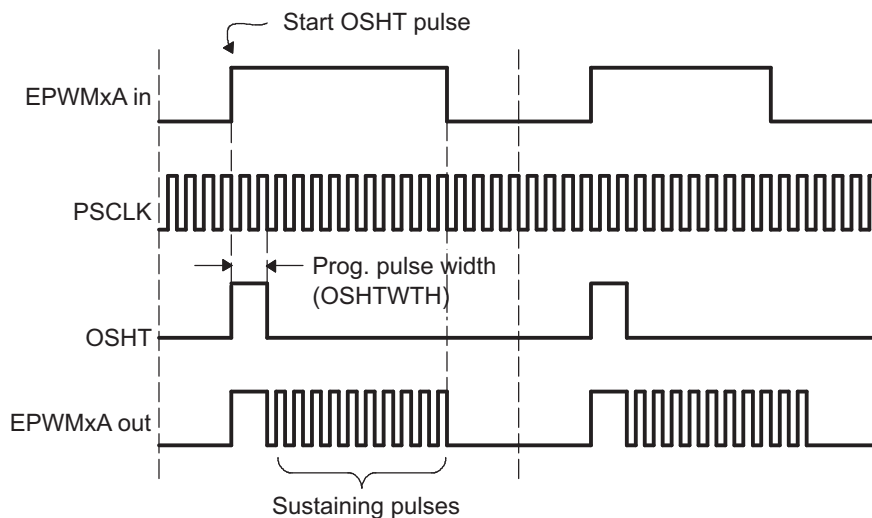

2.7.4.2 Duty Cycle Control

Pulse transformer-based gate drive designs need to comprehend the magnetic properties or characteristics of the transformer and associated circuitry. Saturation is one such consideration. To assist the gate drive designer, the duty cycles of the second and subsequent pulses have been made programmable. These sustaining pulses ensure the correct drive strength and polarity is maintained on the power switch gate during the on period, and hence a programmable duty cycle allows a design to be tuned or optimized via software control.

Figure 35 shows the duty cycle control that is possible by programming the CHPDUTY bits. One of seven possible duty ratios can be selected ranging from 12.5% to 87.5%.

Figure 35. PWM-Chopper Submodule Waveforms Showing the Pulse Width (Duty Cycle) Control of Sustaining Pulses

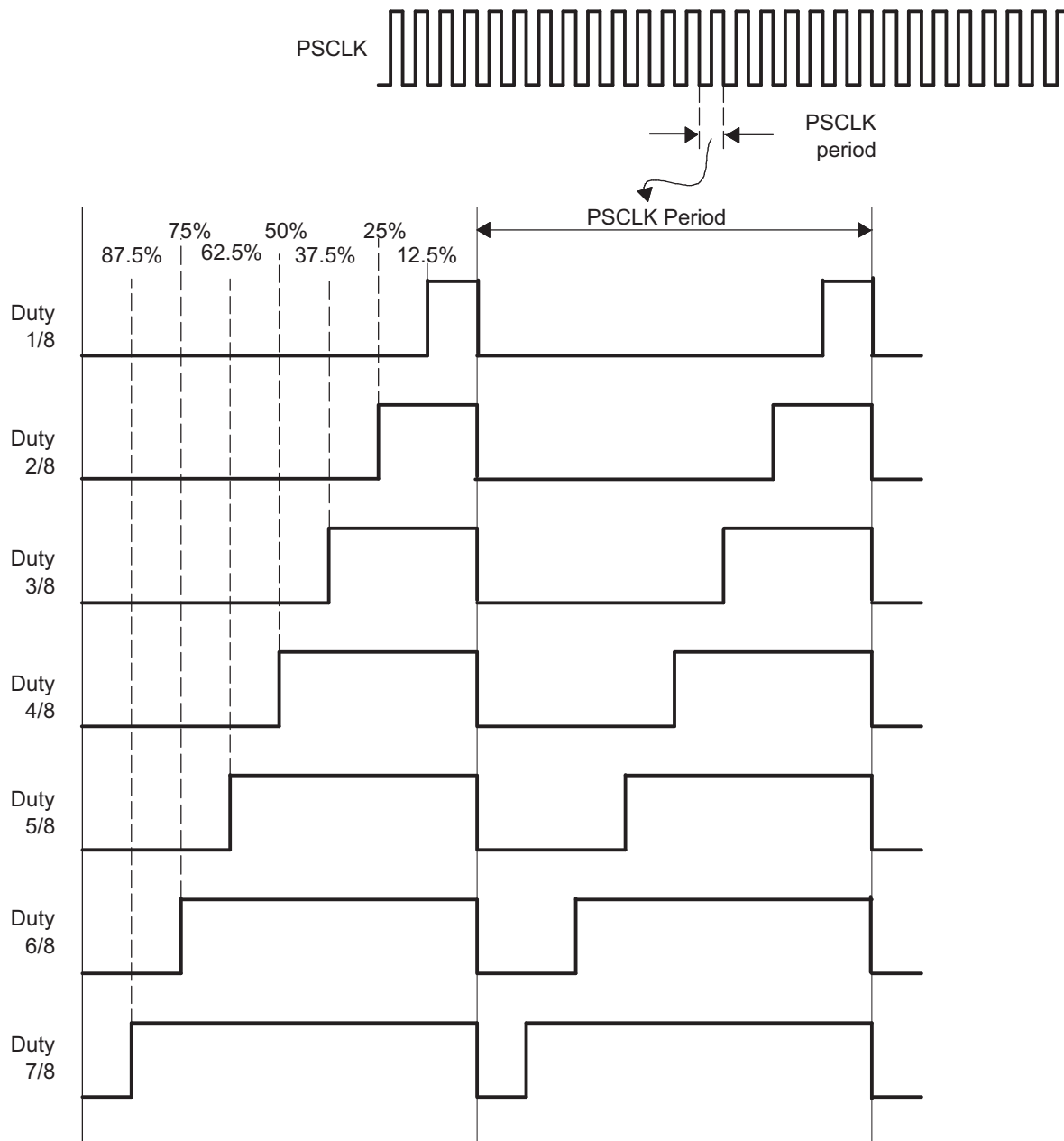

2.8 Trip-Zone (TZ) Submodule

Figure 36 shows how the trip-zone (TZ) submodule fits within the ePWM module. Each ePWM module is connected to every \overline{TZ} signal that are sourced from the GPIO MUX. These signals indicates external fault or trip conditions, and the ePWM outputs can be programmed to respond accordingly when faults occur. See your device-specific data manual to determine the number of trip-zone pins available for the device.

Figure 36. Trip-Zone Submodule

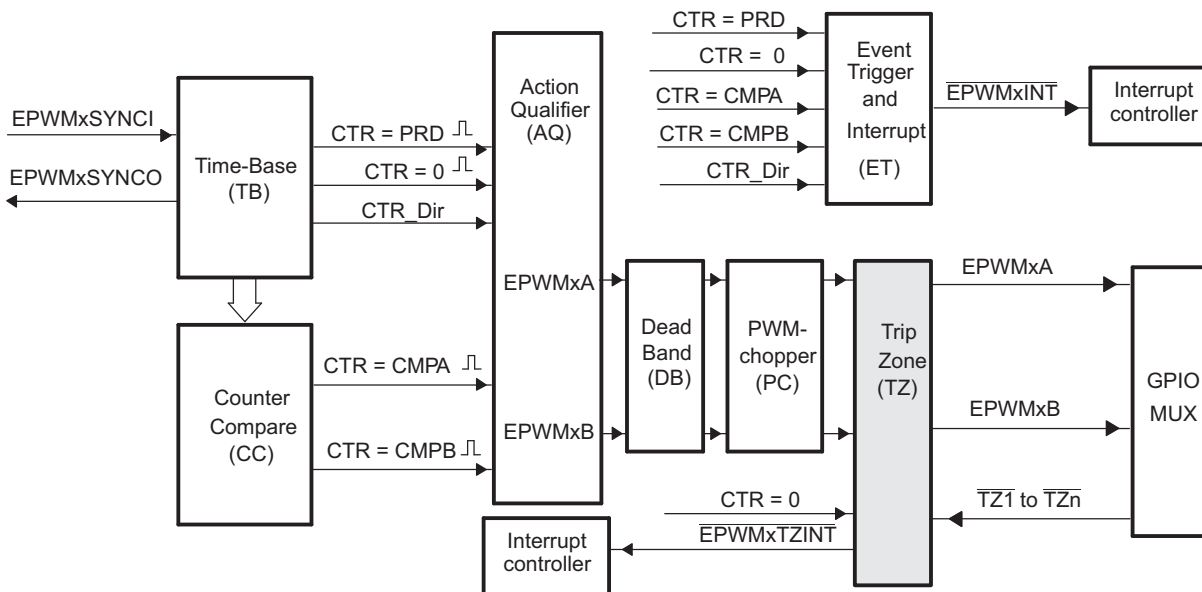

2.8.1 Purpose of the Trip-Zone Submodule

The key functions of the trip-zone submodule are:

- Trip inputs $\overline{TZ1}$ to \overline{TZn} can be flexibly mapped to any ePWM module.
- Upon a fault condition, outputs $EPWMxA$ and $EPWMxB$ can be forced to one of the following:
 - High
 - Low
 - High-impedance
 - No action taken
- Support for one-shot trip (OSHT) for major short circuits or over-current conditions.
- Support for cycle-by-cycle tripping (CBC) for current limiting operation.
- Each trip-zone input pin can be allocated to either one-shot or cycle-by-cycle operation.
- Interrupt generation is possible on any trip-zone pin.
- Software-forced tripping is also supported.
- The trip-zone submodule can be fully bypassed if it is not required.

2.8.2 Controlling and Monitoring the Trip-Zone Submodule

The trip-zone submodule operation is controlled and monitored through the following registers:

Table 28. Trip-Zone Submodule Registers

Acronym	Register Description	Address Offset	Shadowed
TZSEL	Trip-Zone Select Register	24h	No
TZCTL	Trip-Zone Control Register	28h	No
TZEINT	Trip-Zone Enable Interrupt Register	2Ah	No
TZFLG	Trip-Zone Flag Register	2Ch	No
TZCLR	Trip-Zone Clear Register	2Eh	No
TZFRC	Trip-Zone Force Register	30h	No

2.8.3 Operational Highlights for the Trip-Zone Submodule

The following sections describe the operational highlights and configuration options for the trip-zone submodule.

The trip-zone signals at pin $\overline{TZ1}$ to \overline{TZn} is an active-low input signal. When the pin goes low, it indicates that a trip event has occurred. Each ePWM module can be individually configured to ignore or use each of the trip-zone pins. Which trip-zone pins are used by a particular ePWM module is determined by the TZSEL register for that specific ePWM module. The trip-zone signal may or may not be synchronized to the system clock (SYSCLKOUT). A minimum of 1 SYSCLKOUT low pulse on the \overline{TZn} inputs is sufficient to trigger a fault condition in the ePWM module. The asynchronous trip makes sure that if clocks are missing for any reason, the outputs can still be tripped by a valid event present on the \overline{TZn} inputs.

The \overline{TZn} input can be individually configured to provide either a cycle-by-cycle or one-shot trip event for a ePWM module. The configuration is determined by the TZSEL[CBCn] and TZSEL[OSHTn] bits (where n corresponds to the trip pin) respectively.

- **Cycle-by-Cycle (CBC):** When a cycle-by-cycle trip event occurs, the action specified in the TZCTL register is carried out immediately on the EPWMxA and/or EPWMxB output. [Table 29](#) lists the possible actions. In addition, the cycle-by-cycle trip event flag (TZFLG[CBC]) is set and a EPWMxTZINT interrupt is generated if it is enabled in the TZEINT register.

The specified condition on the pins is automatically cleared when the ePWM time-base counter reaches zero (TBCNT = 0000h) if the trip event is no longer present. Therefore, in this mode, the trip event is cleared or reset every PWM cycle. The TZFLG[CBC] flag bit will remain set until it is manually cleared by writing to the TZCLR[CBC] bit. If the cycle-by-cycle trip event is still present when the TZFLG[CBC] bit is cleared, then it will again be immediately set.

- **One-Shot (OSHT):** When a one-shot trip event occurs, the action specified in the TZCTL register is carried out immediately on the EPWMxA and/or EPWMxB output. [Table 29](#) lists the possible actions. In addition, the one-shot trip event flag (TZFLG[OST]) is set and a EPWMxTZINT interrupt is generated if it is enabled in the TZEINT register. The one-shot trip condition must be cleared manually by writing to the TZCLR[OST] bit.

The action taken when a trip event occurs can be configured individually for each of the ePWM output pins by way of the TZCTL[TZA] and TZCTL[TZB] register bits. One of four possible actions, shown in [Table 29](#), can be taken on a trip event.

Table 29. Possible Actions On a Trip Event

TZCTL[TZA] and/or TZCTL[TZB]	EPWMxA and/or EPWMxB	Comment
0	High-Impedance	Tripped
1h	Force to High State	Tripped
2h	Force to Low State	Tripped
3h	No Change	Do Nothing. No change is made to the output.

Example 2. Trip-Zone Configurations

Scenario A:

A one-shot trip event on $\overline{TZ1}$ pulls both EPWM1A, EPWM1B low and also forces EPWM2A and EPWM2B high.

- Configure the ePWM1 registers as follows:
 - TZSEL[OSHT1] = 1: enables \overline{TZ} as a one-shot event source for ePWM1
 - TZCTL[TZA] = 2: EPWM1A will be forced low on a trip event.
 - TZCTL[TZB] = 2: EPWM1B will be forced low on a trip event.
- Configure the ePWM2 registers as follows:
 - TZSEL[OSHT1] = 1: enables \overline{TZ} as a one-shot event source for ePWM2
 - TZCTL[TZA] = 1: EPWM2A will be forced high on a trip event.
 - TZCTL[TZB] = 1: EPWM2B will be forced high on a trip event.

Scenario B:

A cycle-by-cycle event on $\overline{TZ5}$ pulls both EPWM1A, EPWM1B low.

A one-shot event on $\overline{TZ1}$ or $\overline{TZ6}$ puts EPWM2A into a high impedance state.

- Configure the ePWM1 registers as follows:
 - TZSEL[CBC5] = 1: enables $\overline{TZ5}$ as a one-shot event source for ePWM1
 - TZCTL[TZA] = 2: EPWM1A will be forced low on a trip event.
 - TZCTL[TZB] = 2: EPWM1B will be forced low on a trip event.
- Configure the ePWM2 registers as follows:
 - TZSEL[OSHT1] = 1: enables $\overline{TZ1}$ as a one-shot event source for ePWM2
 - TZSEL[OSHT6] = 1: enables $\overline{TZ6}$ as a one-shot event source for ePWM1
 - TZCTL[TZA] = 0: EPWM1A will be put into a high-impedance state on a trip event.
 - TZCTL[TZB] = 3: EPWM1B will ignore the trip event.

2.8.4 Generating Trip Event Interrupts

Figure 37 and Figure 38 illustrate the trip-zone submodule control and interrupt logic, respectively.

Figure 37. Trip-Zone Submodule Mode Control Logic

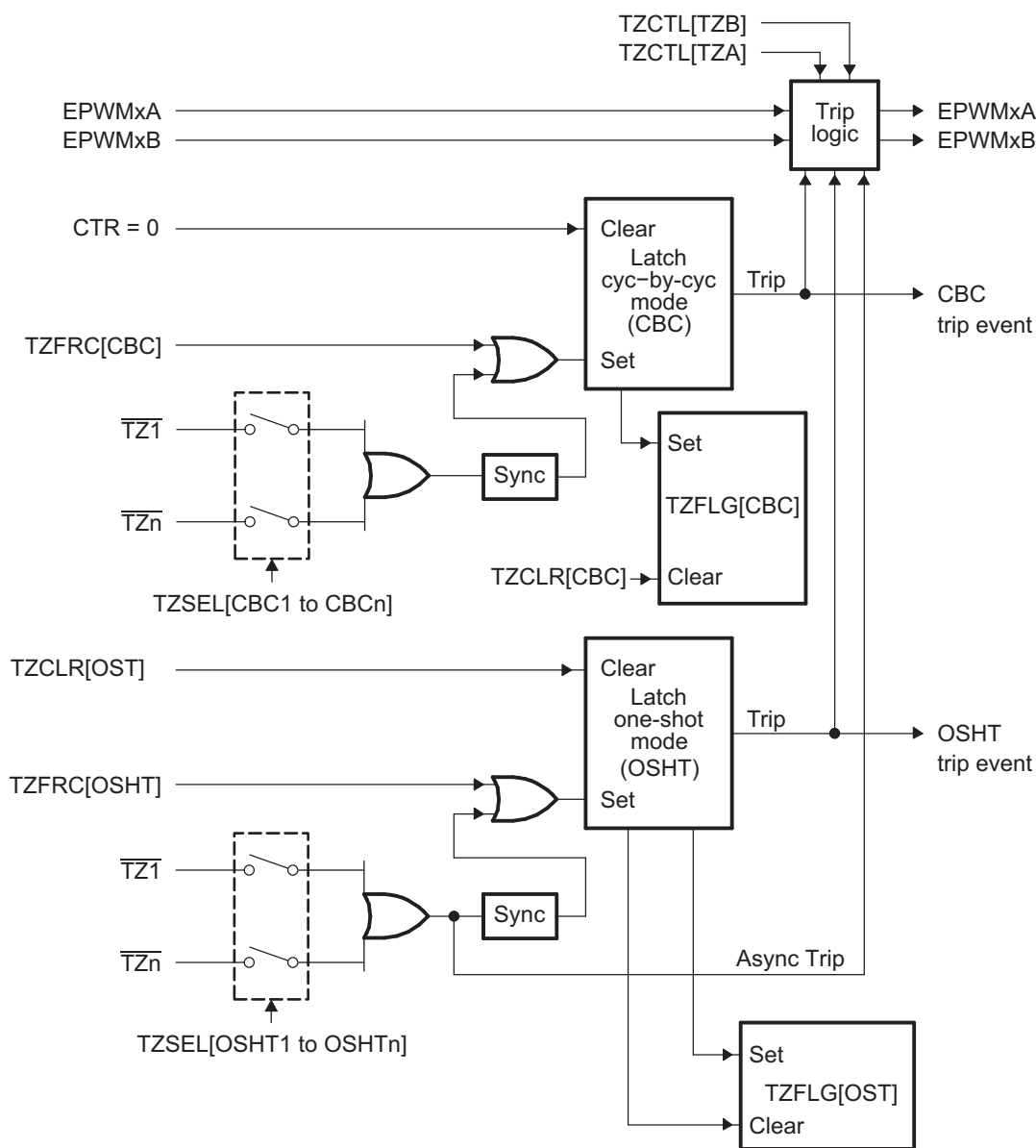
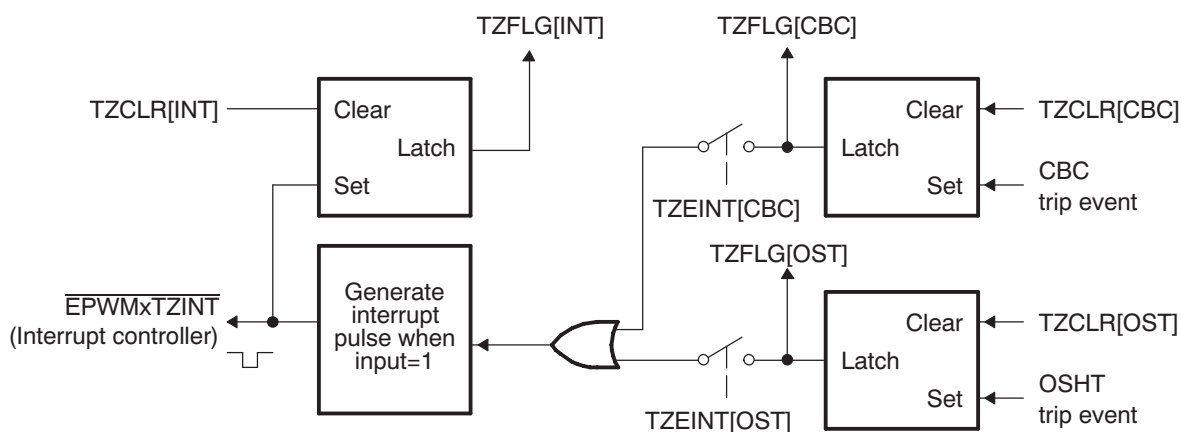

Figure 38. Trip-Zone Submodule Interrupt Logic



2.9 Event-Trigger (ET) Submodule

Figure 39 shows the event-trigger (ET) submodule in the ePWM system. The event-trigger submodule manages the events generated by the time-base submodule and the counter-compare submodule to generate an interrupt to the CPU.

Figure 39. Event-Trigger Submodule

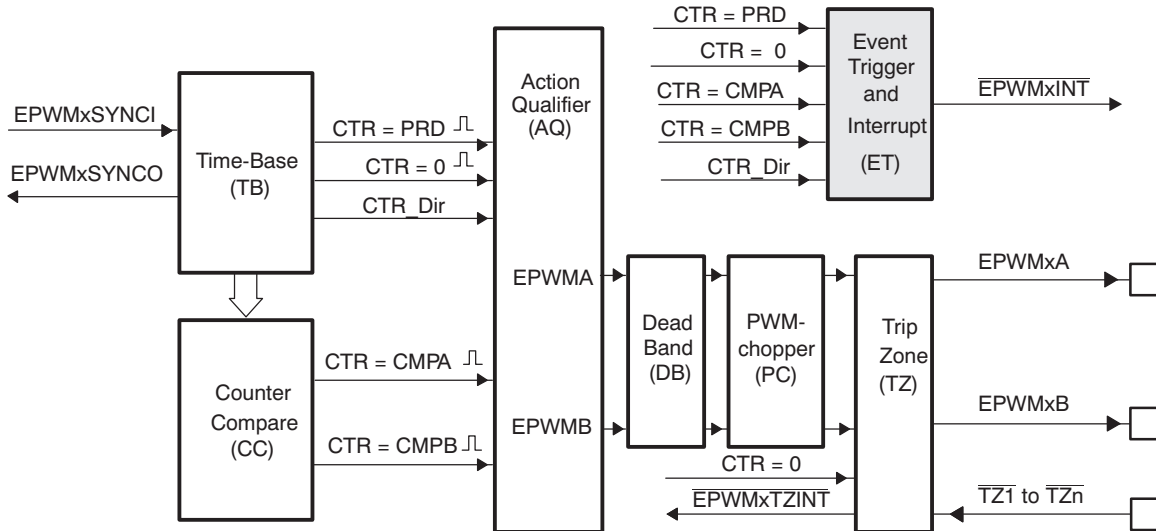

2.9.1 Purpose of the Event-Trigger Submodule

The key functions of the event-trigger submodule are:

- Receives event inputs generated by the time-base and counter-compare submodules
- Uses the time-base direction information for up/down event qualification
- Uses prescaling logic to issue interrupt requests at:
 - Every event
 - Every second event
 - Every third event
- Provides full visibility of event generation via event counters and flags

2.9.2 Controlling and Monitoring the Event-Trigger Submodule

The key registers used to configure the event-trigger submodule are shown in Table 30:

Table 30. Event-Trigger Submodule Registers

Acronym	Register Description	Address Offset	Shadowed
ETSEL	Event-Trigger Selection Register	32h	No
ETPS	Event-Trigger Prescale Register	34h	No
ETFLG	Event-Trigger Flag Register	36h	No
ETCLR	Event-Trigger Clear Register	38h	No
ETFRC	Event-Trigger Force Register	3Ah	No

2.9.3 Operational Overview of the Event-Trigger Submodule

The following sections describe the event-trigger submodule's operational highlights.

Each ePWM module has one interrupt request line connected to the interrupt controller as shown in Figure 40.

Figure 40. Event-Trigger Submodule Inter-Connectivity to Interrupt Controller

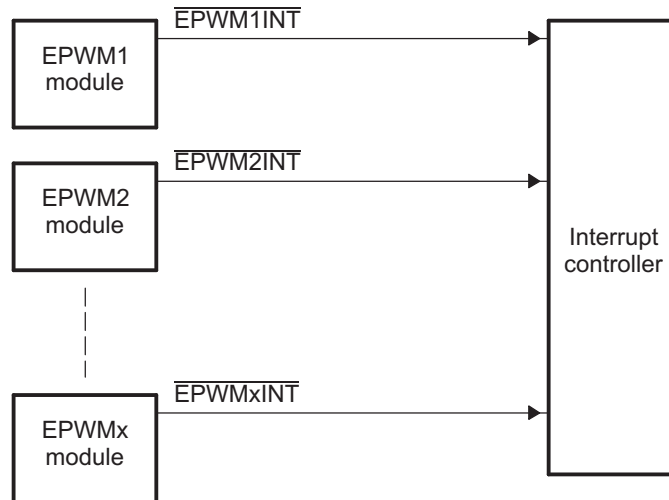

The event-trigger submodule monitors various event conditions (the left side inputs to event-trigger submodule shown in Figure 41) and can be configured to prescale these events before issuing an Interrupt request. The event-trigger prescaling logic can issue Interrupt requests at:

- Every event
- Every second event
- Every third event

Figure 41. Event-Trigger Submodule Showing Event Inputs and Prescaled Outputs

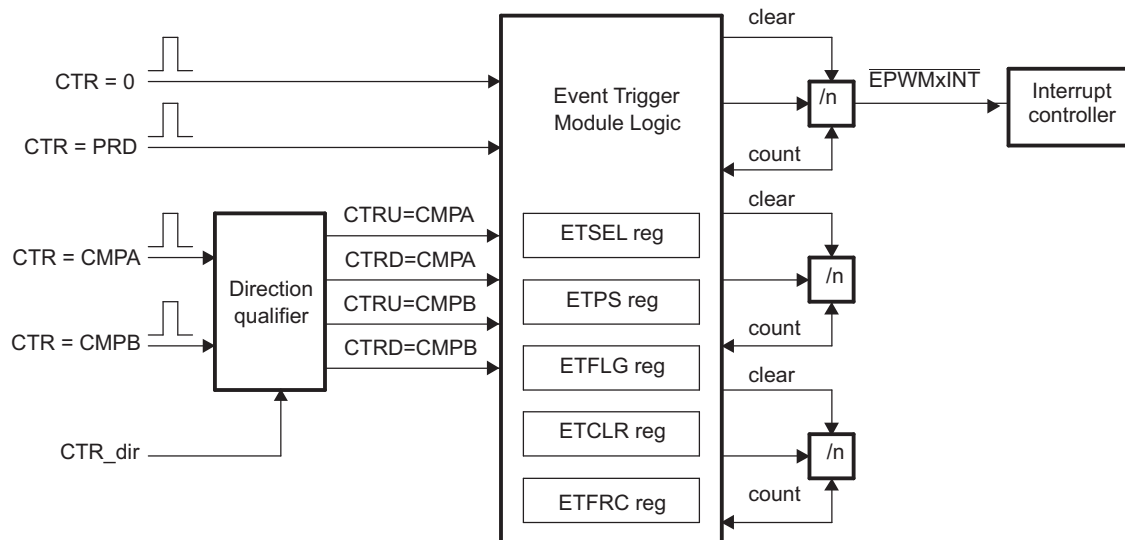

- ETSEL—This selects which of the possible events will trigger an interrupt.
- ETPS—This programs the event prescaling options previously mentioned.
- ETFLG—These are flag bits indicating status of the selected and prescaled events.
- ETCLR—These bits allow you to clear the flag bits in the ETFLG register via software.
- ETFRC—These bits allow software forcing of an event. Useful for debugging or software intervention.

A more detailed look at how the various register bits interact with the Interrupt is shown in [Figure 42](#).

[Figure 42](#) shows the event-trigger's interrupt generation logic. The interrupt-period (ETPS[INTPRD]) bits specify the number of events required to cause an interrupt pulse to be generated. The choices available are:

- Do not generate an interrupt
- Generate an interrupt on every event
- Generate an interrupt on every second event
- Generate an interrupt on every third event

An interrupt cannot be generated on every fourth or more events.

Which event can cause an interrupt is configured by the interrupt selection (ETSEL[INTSEL]) bits. The event can be one of the following:

- Time-base counter equal to zero (TBCNT = 0000h).
- Time-base counter equal to period (TBCNT = TBPRD).
- Time-base counter equal to the compare A register (CMPA) when the timer is incrementing.
- Time-base counter equal to the compare A register (CMPA) when the timer is decrementing.
- Time-base counter equal to the compare B register (CMPB) when the timer is incrementing.
- Time-base counter equal to the compare B register (CMPB) when the timer is decrementing.

The number of events that have occurred can be read from the interrupt event counter (ETPS[INTCNT]) register bits. That is, when the specified event occurs the ETPS[INTCNT] bits are incremented until they reach the value specified by ETPS[INTPRD]. When ETPS[INTCNT] = ETPS[INTPRD] the counter stops counting and its output is set. The counter is only cleared when an interrupt is sent to the interrupt controller.

When ETPS[INTCNT] reaches ETPS[INTPRD], one of the following behaviors will occur:

- If interrupts are enabled, ETSEL[INTEN] = 1 and the interrupt flag is clear, ETFLG[INT] = 0, then an interrupt pulse is generated and the interrupt flag is set, ETFLG[INT] = 1, and the event counter is cleared ETPS[INTCNT] = 0. The counter will begin counting events again.
- If interrupts are disabled, ETSEL[INTEN] = 0, or the interrupt flag is set, ETFLG[INT] = 1, the counter stops counting events when it reaches the period value ETPS[INTCNT] = ETPS[INTPRD].
- If interrupts are enabled, but the interrupt flag is already set, then the counter will hold its output high until the ETFLG[INT] flag is cleared. This allows for one interrupt to be pending while one is serviced.

Writing to the INTPRD bits will automatically clear the counter INTCNT = 0 and the counter output will be reset (so no interrupts are generated). Writing a 1 to the ETFRC[INT] bit will increment the event counter INTCNT. The counter will behave as described above when INTCNT = INTPRD. When INTPRD = 0, the counter is disabled and hence no events will be detected and the ETFRC[INT] bit is also ignored.

Figure 42. Event-Trigger Interrupt Generator

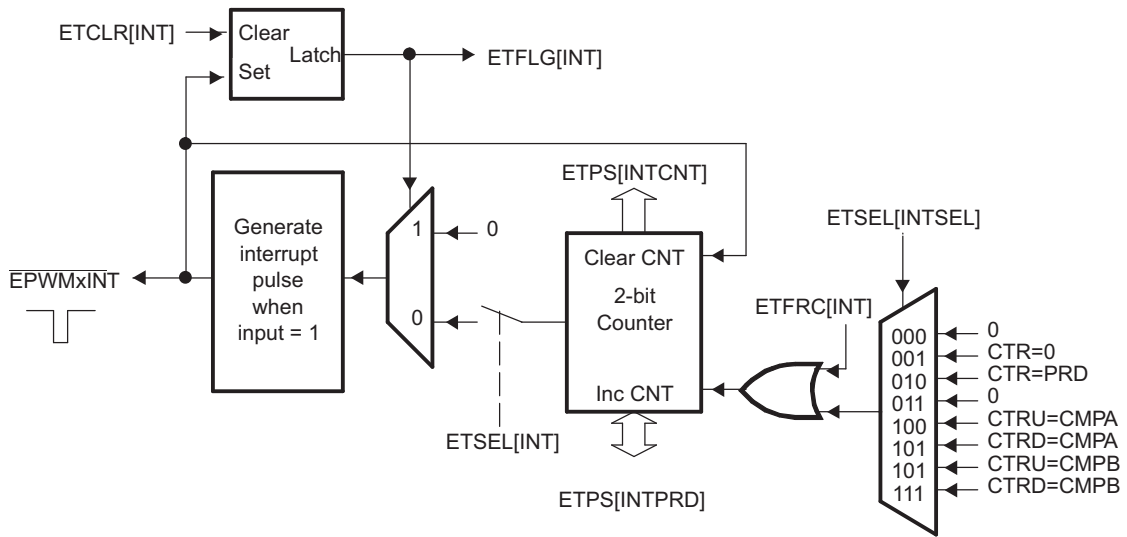

2.10 High-Resolution PWM (HRPWM) Submodule

Figure 43 shows the high-resolution PWM (HRPWM) submodule in the ePWM system. Some devices include the high-resolution PWM submodule, see your device-specific data manual to determine which ePWM instances include this feature.

Figure 43. HRPWM System Interface

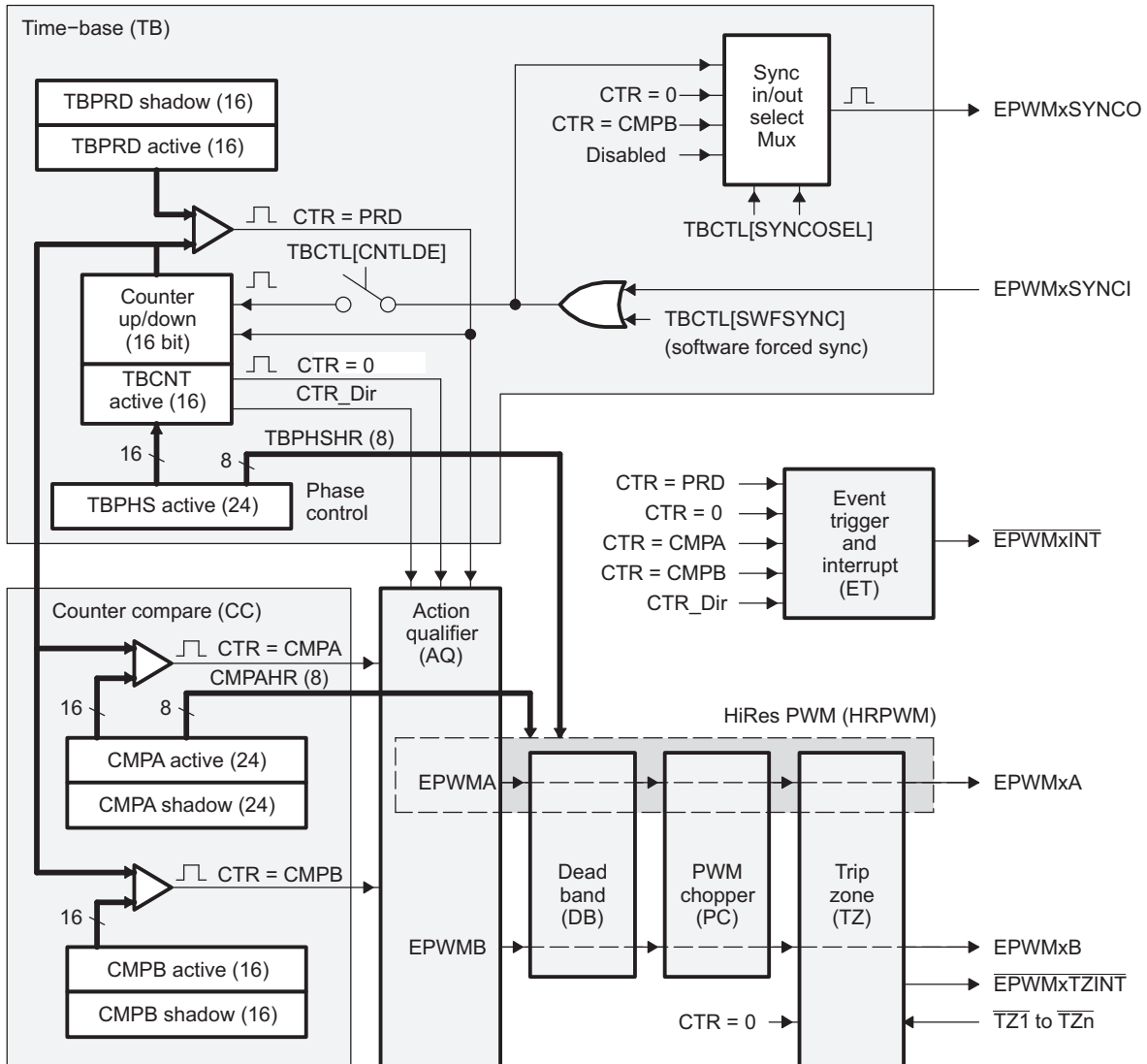

2.10.1 Purpose of the High-Resolution PWM Submodule

The enhanced high-resolution pulse-width modulator (eHRPWM) extends the time resolution capabilities of the conventionally derived digital pulse-width modulator (PWM). HRPWM is typically used when PWM resolution falls below ~9-10 bits. The key features of HRPWM are:

- Extended time resolution capability
- Used in both duty cycle and phase-shift control methods
- Finer time granularity control or edge positioning using extensions to the Compare A and Phase registers
- Implemented using the A signal path of PWM, that is, on the EPWMxA output. EPWMxB output has conventional PWM capabilities

The ePWM peripheral is used to perform a function that is mathematically equivalent to a digital-to-analog converter (DAC). As shown in [Figure 44](#), the effective resolution for conventionally generated PWM is a function of PWM frequency (or period) and system clock frequency.

Figure 44. Resolution Calculations for Conventionally Generated PWM

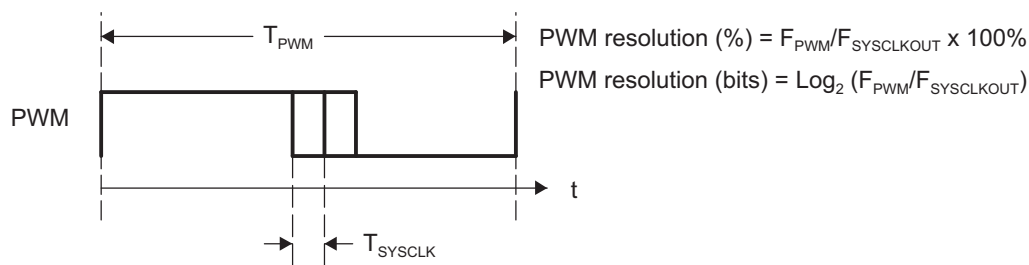

If the required PWM operating frequency does not offer sufficient resolution in PWM mode, you may want to consider HRPWM. As an example of improved performance offered by HRPWM, [Table 31](#) shows resolution in bits for various PWM frequencies. [Table 31](#) values assume a MEP step size of 180 ps. See your device-specific data manual for typical and maximum performance specifications for the MEP.

Table 31. Resolution for PWM and HRPWM

PWM Frequency (kHz)	Regular Resolution (PWM)		High Resolution (HRPWM)	
	Bits	%	Bits	%
20	12.3	0.0	18.1	0.000
50	11.0	0.0	16.8	0.001
100	10.0	0.1	15.8	0.002
150	9.4	0.2	15.2	0.003
200	9.0	0.2	14.8	0.004
250	8.6	0.3	14.4	0.005
500	7.6	0.5	13.8	0.007
1000	6.6	1.0	12.4	0.018
1500	6.1	1.5	11.9	0.027
2000	5.6	2.0	11.4	0.036

Although each application may differ, typical low-frequency PWM operation (below 250 kHz) may not require HRPWM. HRPWM capability is most useful for high-frequency PWM requirements of power conversion topologies such as:

- Single-phase buck, boost, and flyback
- Multi-phase buck, boost, and flyback
- Phase-shifted full bridge
- Direct modulation of D-Class power amplifiers

2.10.2 Architecture of the High-Resolution PWM Submodule

The HRPWM is based on micro edge positioner (MEP) technology. MEP logic is capable of positioning an edge very finely by sub-dividing one coarse system clock of a conventional PWM generator. The time step accuracy is on the order of 150 ps. The HRPWM also has a self-check software diagnostics mode to check if the MEP logic is running optimally, under all operating conditions.

Figure 45 shows the relationship between one coarse system clock and edge position in terms of MEP steps, which are controlled via an 8-bit field in the Compare A extension register (CMPAHR).

Figure 45. Operating Logic Using MEP

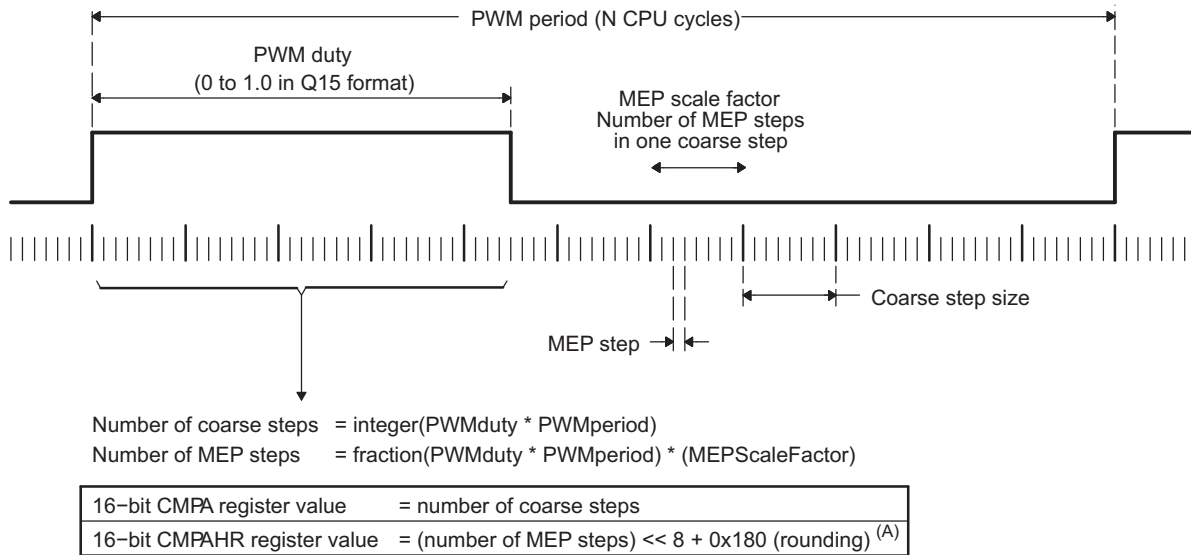

A For MEP range and rounding adjustment.

To generate an HRPWM waveform, configure the TBM, CCM, and AQM registers as you would to generate a conventional PWM of a given frequency and polarity. The HRPWM works together with the TBM, CCM, and AQM registers to extend edge resolution, and should be configured accordingly. Although many programming combinations are possible, only a few are needed and practical.

2.10.3 Controlling and Monitoring the High-Resolution PWM Submodule

The MEP of the HRPWM is controlled by two extension registers, each 8-bits wide. These two HRPWM registers are concatenated with the 16-bit TBPHS and CMPA registers used to control PWM operation.

- TBPHSHR - Time-Base Phase High-Resolution Register
- CMPAHR - Counter-Compare A High-Resolution Register

Table 32 lists the registers used to control and monitor the high-resolution PWM submodule.

Table 32. HRPWM Submodule Registers

Acronym	Register Description	Address Offset	Shadowed
TBPHSHR	Extension Register for HRPWM Phase	4h	No
CMPAHR	Extension Register for HRPWM Duty	10h	Yes
HRCNFG ⁽¹⁾	HRPWM Configuration Register	1020h	No

⁽¹⁾ This register is EALLOW protected.

2.10.4 Configuring the High-Resolution PWM Submodule

Once the ePWM has been configured to provide conventional PWM of a given frequency and polarity, the HRPWM is configured by programming the HRCNFG register located at offset address 1020h. This register provides configuration options for the following key operating modes:

- **Edge Mode:** The MEP can be programmed to provide precise position control on the rising edge (RE), falling edge (FE), or both edges (BE) at the same time. FE and RE are used for power topologies requiring duty cycle control, while BE is used for topologies requiring phase shifting, for example, phase shifted full bridge.
- **Control Mode:** The MEP is programmed to be controlled either from the CMPAHR register (duty cycle control) or the TBPMSHR register (phase control). RE or FE control mode should be used with CMPAHR register. BE control mode should be used with TBPMSHR register.
- **Shadow Mode:** This mode provides the same shadowing (double buffering) option as in regular PWM mode. This option is valid only when operating from the CMPAHR register and should be chosen to be the same as the regular load option for the CMPA register. If TBPMSHR is used, then this option has no effect.

2.10.5 Operational Highlights for the High-Resolution PWM Submodule

The MEP logic is capable of placing an edge in one of 255 (8 bits) discrete time steps, each of which has a time resolution on the order of 150 ps. The MEP works with the TBM and CCM registers to be certain that time steps are optimally applied and that edge placement accuracy is maintained over a wide range of PWM frequencies, system clock frequencies and other operating conditions. [Table 33](#) shows the typical range of operating frequencies supported by the HRPWM.

Table 33. Relationship Between MEP Steps, PWM Frequency and Resolution

System (MHz)	MEP Steps Per SYSCLKOUT ⁽¹⁾ ⁽²⁾ ⁽³⁾	PWM Minimum (Hz) ⁽⁴⁾	PWM Maximum (MHz)	Resolution at Maximum (Bits) ⁽⁵⁾
50.0	111	763	2.50	11.1
60.0	93	916	3.00	10.9
70.0	79	1068	3.50	10.6
80.0	69	1221	4.00	10.4
90.0	62	1373	4.50	10.3
100.0	56	1526	5.00	10.1

⁽¹⁾ System frequency = SYSCLKOUT, that is, CPU clock. TBCLK = SYSCLKOUT

⁽²⁾ Table data based on a MEP time resolution of 180 ps (this is an example value)

⁽³⁾ MEP steps applied = $T_{\text{SYSCLKOUT}}/180 \text{ ps}$ in this example.

⁽⁴⁾ PWM minimum frequency is based on a maximum period value, TBPRD = 65 535. PWM mode is asymmetrical up-count.

⁽⁵⁾ Resolution in bits is given for the maximum PWM frequency stated.

2.10.5.1 Edge Positioning

In a typical power control loop (switch modes, digital motor control (DMC), uninterruptible power supply (UPS)), a digital controller (PID, 2pole/2zero, lag/lead, etc.) issues a duty command, usually expressed in a per unit or percentage terms.

In the following example, assume that for a particular operating point, the demanded duty cycle is 0.405 or 40.5% on-time and the required converter PWM frequency is 1.25 MHz. In conventional PWM generation with a system clock of 100 MHz, the duty cycle choices are in the vicinity of 40.5%. In [Figure 46](#), a compare value of 32 counts (duty = 40%) is the closest to 40.5% that you can attain. This is equivalent to an edge position of 320 ns instead of the desired 324 ns. This data is shown in [Table 34](#).

By utilizing the MEP, you can achieve an edge position much closer to the desired point of 324 ns. [Table 34](#) shows that in addition to the CMPA value, 22 steps of the MEP (CMPAHR register) will position the edge at 323.96 ns, resulting in almost zero error. In this example, it is assumed that the MEP has a step resolution of 180 ns.

Figure 46. Required PWM Waveform for a Requested Duty = 40.5%

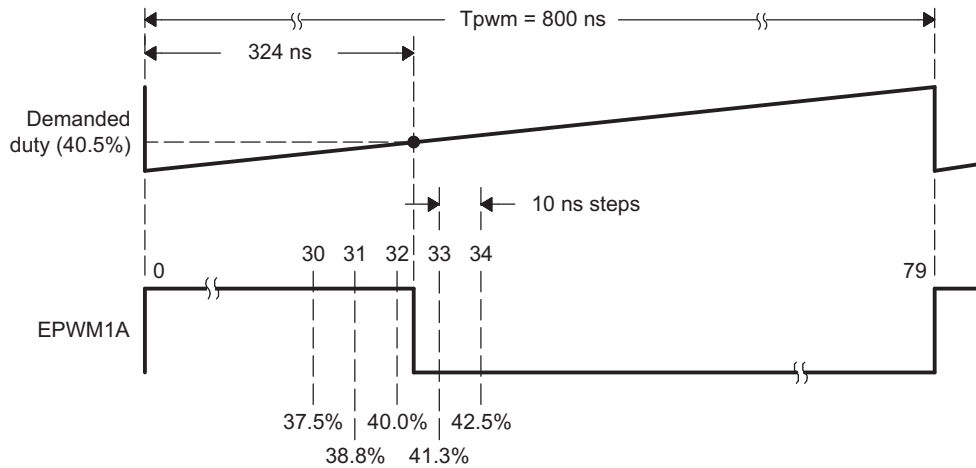

Table 34. CMPA vs Duty (left), and [CMPA:CMPAHR] vs Duty (right)

CMPA (count) ⁽¹⁾ ⁽²⁾ ⁽³⁾	DUTY (%)	High Time (ns)	CMPA (count)	CMPAHR (count)	Duty (%)	High Time (ns)
28	35.0	280	32	18	40.405	323.24
29	36.3	290	32	19	40.428	323.42
30	37.5	300	32	20	40.450	323.60
31	38.8	310	32	21	40.473	323.78
32	40.0	320	32	22	40.495	323.96
33	41.3	330	32	23	40.518	324.14
34	42.5	340	32	24	40.540	324.32
			32	25	40.563	324.50
Required			32	26	40.585	324.68
32.40	40.5	324	32	27	40.608	324.86

⁽¹⁾ System clock, SYSCLKOUT and TBCLK = 100 MHz, 10 ns

⁽²⁾ For a PWM Period register value of 80 counts, PWM Period = 80 × 10 ns = 800 ns, PWM frequency = 1/800 ns = 1.25 MHz

⁽³⁾ Assumed MEP step size for the above example = 180 ps

2.10.5.2 Scaling Considerations

The mechanics of how to position an edge precisely in time has been demonstrated using the resources of the standard (CMPA) and MEP (CMPAHR) registers. In a practical application, however, it is necessary to seamlessly provide the CPU a mapping function from a per-unit (fractional) duty cycle to a final integer (non-fractional) representation that is written to the [CMPA:CMPAHR] register combination.

To do this, first examine the scaling or mapping steps involved. It is common in control software to express duty cycle in a per-unit or percentage basis. This has the advantage of performing all needed math calculations without concern for the final absolute duty cycle, expressed in clock counts or high time in ns. Furthermore, it makes the code more transportable across multiple converter types running different PWM frequencies.

To implement the mapping scheme, a two-step scaling procedure is required.

Assumptions for this example:

System clock, SYSCLKOUT	= 10 ns (100 MHz)
PWM frequency	= 1.25 MHz (1/800 ns)
Required PWM duty cycle, PWMDuty	= 0.405 (40.5%)
PWM period in terms of coarse steps, PWMperiod (800 ns/10 ns)	= 80
Number of MEP steps per coarse step at 180 ps (10 ns/180 ps), MEP_SF	= 55
Value to keep CMPAHR within the range of 1-255 and fractional rounding constant (default value)	= 180h

Step 1: Percentage Integer Duty value conversion for CMPA register

CMPA register value	= $\text{int}(\text{PWMDuty} \times \text{PWMperiod})$; int means integer part
	= $\text{int}(0.405 \times 80)$
	= $\text{int}(32.4)$
CMPA register value	= 32 (20h)

Step 2: Fractional value conversion for CMPAHR register

CMPAHR register value	= $(\text{frac}(\text{PWMDuty} \times \text{PWMperiod}) \times \text{MEP_SF}) \ll 8) + 180\text{h}$; frac means fractional part
	= $(\text{frac}(32.4) \times 55 \ll 8) + 180\text{h}$; Shift is to move the value as CMPAHR high byte
	= $((0.4 \times 55) \ll 8) + 180\text{h}$
	= $(22 \ll 8) + 180\text{h}$
	= $22 \times 256 + 180\text{h}$; Shifting left by 8 is the same multiplying by 256.
	= $5632 + 180\text{h}$
	= $1600\text{h} + 180\text{h}$
CMPAHR value	= 1780h; CMPAHR value = 1700h, lower 8 bits will be ignored by hardware.

2.10.5.3 Duty Cycle Range Limitation

In high resolution mode, the MEP is not active for 100% of the PWM period. It becomes operational 3 SYSCLK cycles after the period starts.

Duty cycle range limitations are illustrated in Figure 47. This limitation imposes a lower duty cycle limit on the MEP. For example, precision edge control is not available all the way down to 0% duty cycle. Although for the first 3 or 6 cycles, the HRPWM capabilities are not available, regular PWM duty control is still fully operational down to 0% duty. In most applications this should not be an issue as the controller regulation point is usually not designed to be close to 0% duty cycle.

Figure 47. Low % Duty Cycle Range Limitation Example When PWM Frequency = 1 MHz

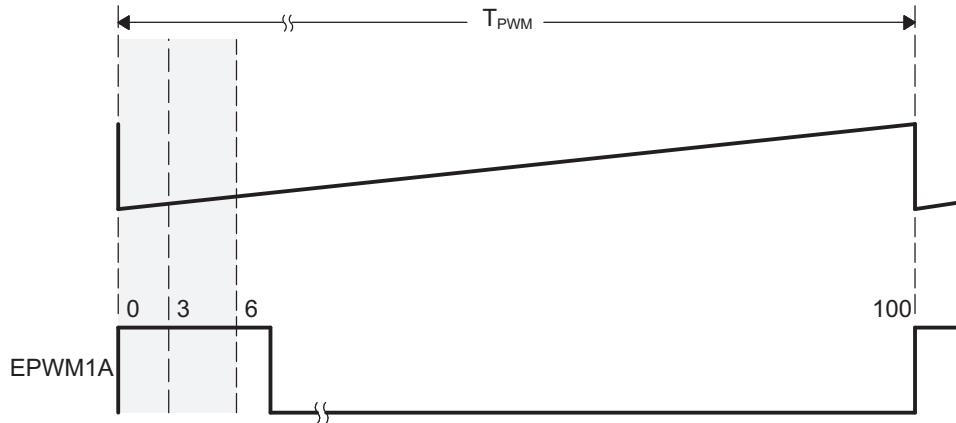

If the application demands HRPWM operation in the low percent duty cycle region, then the HRPWM can be configured to operate in count-down mode with the rising edge position (REP) controlled by the MEP. This is illustrated in Figure 48. In this case low percent duty limitation is no longer an issue.

Figure 48. High % Duty Cycle Range Limitation Example when PWM Frequency = 1 MHz

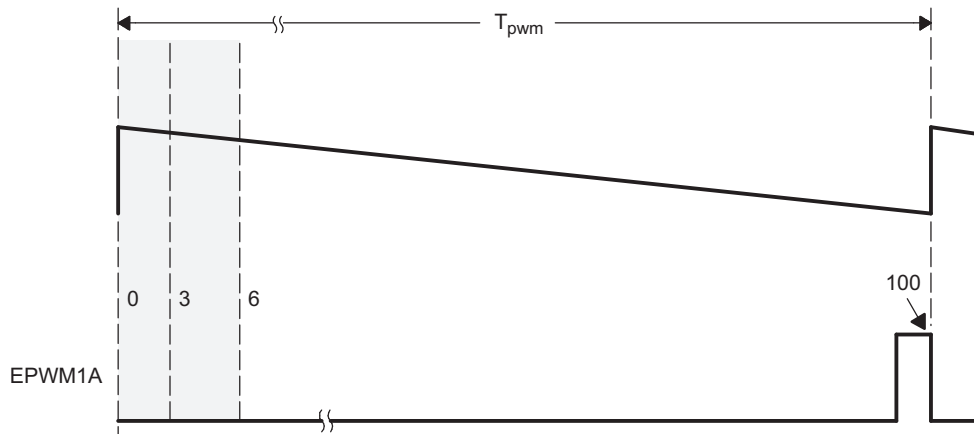

3 Applications to Power Topologies

An ePWM module has all the local resources necessary to operate completely as a standalone module or to operate in synchronization with other identical ePWM modules.

3.1 Overview of Multiple Modules

Previously in this user's guide, all discussions have described the operation of a single module. To facilitate the understanding of multiple modules working together in a system, the ePWM module described in reference is represented by the more simplified block diagram shown in Figure 49. This simplified ePWM block shows only the key resources needed to explain how a multistwitch power topology is controlled with multiple ePWM modules working together.

Figure 49. Simplified ePWM Module

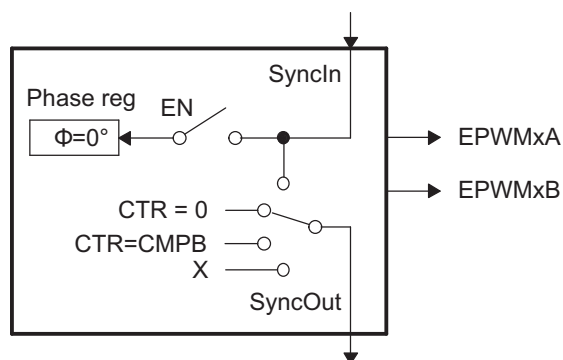

3.2 Key Configuration Capabilities

The key configuration choices available to each module are as follows:

- Options for SyncIn
 - Load own counter with phase register on an incoming sync strobe—enable (EN) switch closed
 - Do nothing or ignore incoming sync strobe—enable switch open
 - Sync flow-through - SyncOut connected to SyncIn
 - Master mode, provides a sync at PWM boundaries—SyncOut connected to CTR = PRD
 - Master mode, provides a sync at any programmable point in time—SyncOut connected to CTR = CMPB
 - Module is in standalone mode and provides No sync to other modules—SyncOut connected to X (disabled)
- Options for SyncOut
 - Sync flow-through - SyncOut connected to SyncIn
 - Master mode, provides a sync at PWM boundaries—SyncOut connected to CTR = PRD
 - Master mode, provides a sync at any programmable point in time—SyncOut connected to CTR = CMPB
 - Module is in standalone mode and provides No sync to other modules—SyncOut connected to X (disabled)

For each choice of SyncOut, a module may also choose to load its own counter with a new phase value on a SyncIn strobe input or choose to ignore it, i.e., via the enable switch. Although various combinations are possible, the two most common—master module and slave module modes—are shown in [Figure 50](#).

Figure 50. EPWM1 Configured as a Typical Master, EPWM2 Configured as a Slave

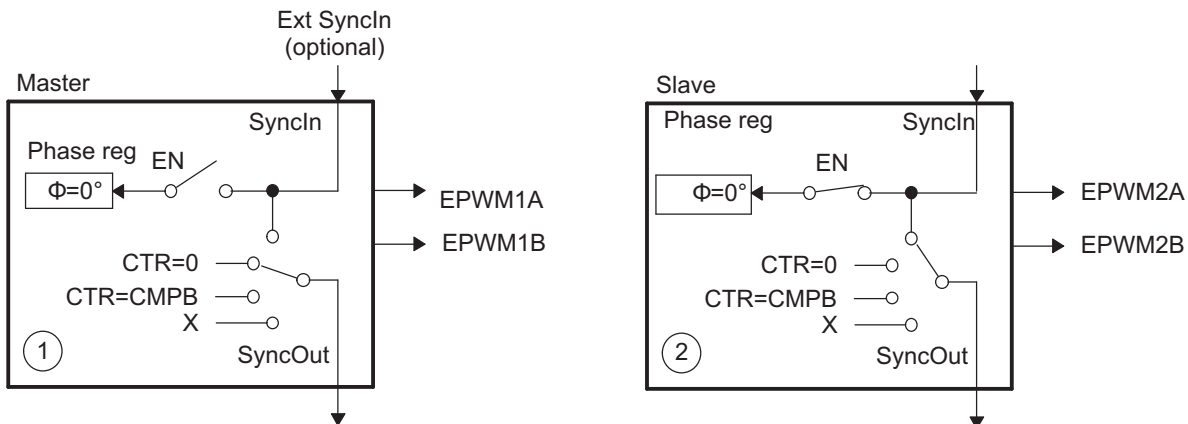

3.3 Controlling Multiple Buck Converters With Independent Frequencies

One of the simplest power converter topologies is the buck. A single ePWM module configured as a master can control two buck stages with the same PWM frequency. If independent frequency control is required for each buck converter, then one ePWM module must be allocated for each converter stage. Figure 51 shows four buck stages, each running at independent frequencies. In this case, all four ePWM modules are configured as Masters and no synchronization is used. Figure 52 shows the waveforms generated by the setup shown in Figure 51; note that only three waveforms are shown, although there are four stages.

Figure 51. Control of Four Buck Stages. Here $F_{PWM1} \neq F_{PWM2} \neq F_{PWM3} \neq F_{PWM4}$

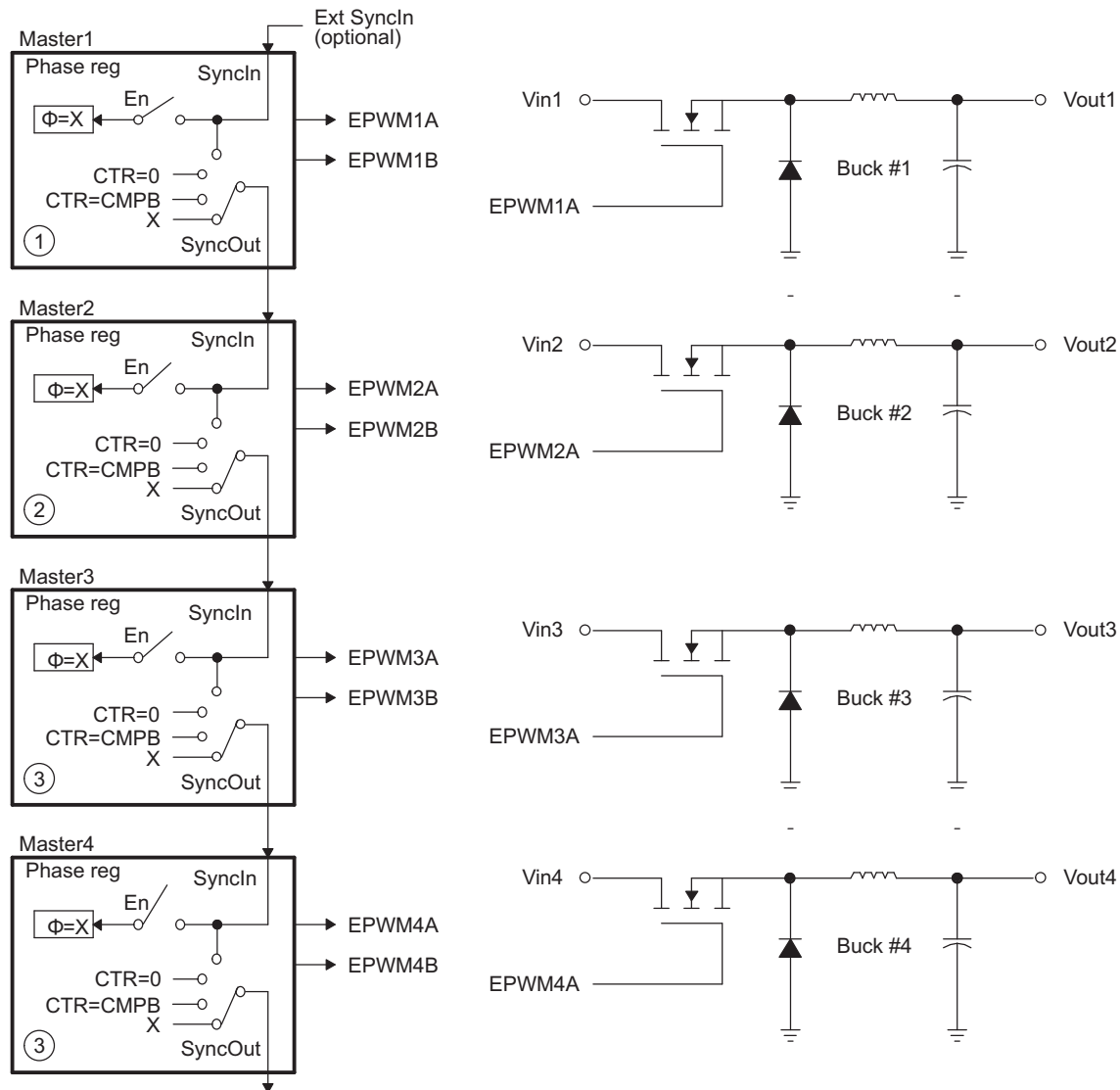

NOTE: $\Phi = X$ indicates value in phase register is a "don't care"

Figure 52. Buck Waveforms for Figure 51 (Note: Only three bucks shown here)

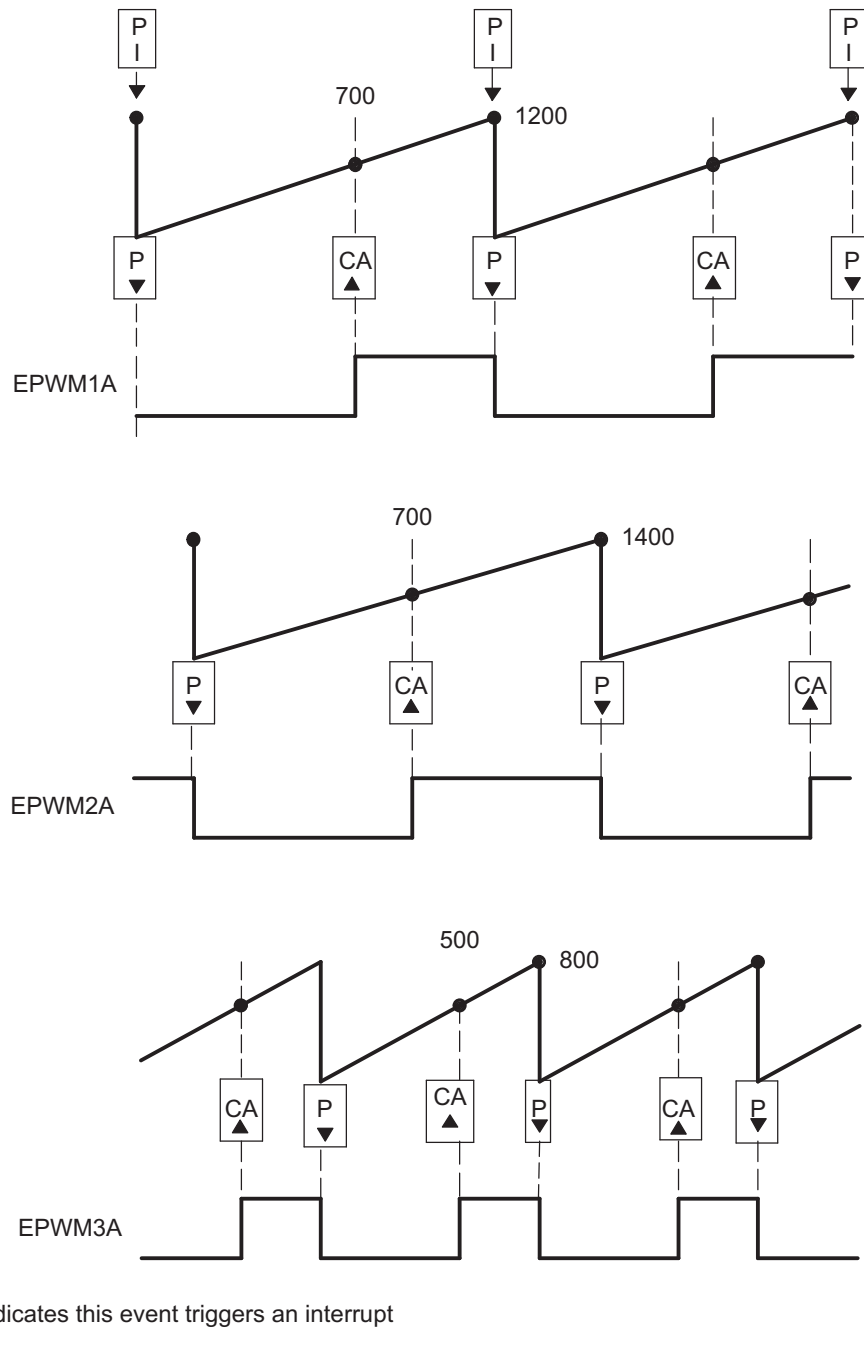

Table 35. EPWM1 Initialization for Figure 52

Register	Bit	Value	Comments
TBPRD	TBPRD	1200 (4B0h)	Period = 1201 TBCLK counts
TBPHS	TBPHS	0	Clear Phase Register to 0
TBCTL	CTRMODE	TB_UP	
	PHSEN	TB_DISABLE	Phase loading disabled
	PRDL	TB_SHADOW	
	SYNCOSEL	TB_SYNC_DISABLE	
CMPCTL	SHDWAMODE	CC_SHADOW	
	SHDWBMODE	CC_SHADOW	
	LOADAMODE	CC_CTR_ZERO	Load on CTR = 0
	LOADBMODE	CC_CTR_ZERO	Load on CTR = 0
AQCTLA	PRD	AQ_CLEAR	
	CAU	AQ_SET	

Table 36. EPWM2 Initialization for Figure 52

Register	Bit	Value	Comments
TBPRD	TBPRD	1400 (578h)	Period = 1401 TBCLK counts
TBPHS	TBPHS	0	Clear Phase Register to 0
TBCTL	CTRMODE	TB_UP	
	PHSEN	TB_DISABLE	Phase loading disabled
	PRDL	TB_SHADOW	
	SYNCOSEL	TB_SYNC_DISABLE	
CMPCTL	SHDWAMODE	CC_SHADOW	
	SHDWBMODE	CC_SHADOW	
	LOADAMODE	CC_CTR_ZERO	Load on CTR = 0
	LOADBMODE	CC_CTR_ZERO	Load on CTR = 0
AQCTLA	PRD	AQ_CLEAR	
	CAU	AQ_SET	

Table 37. EPWM3 Initialization for Figure 52

Register	Bit	Value	Comments
TBPRD	TBPRD	800 (320h)	Period = 801 TBCLK counts
TBPHS	TBPHS	0	Clear Phase Register to 0
TBCTL	CTRMODE	TB_UP	
	PHSEN	TB_DISABLE	Phase loading disabled
	PRDL	TB_SHADOW	
	SYNCOSEL	TB_SYNC_DISABLE	
CMPCTL	SHDWAMODE	CC_SHADOW	
	SHDWBMODE	CC_SHADOW	
	LOADAMODE	CC_CTR_ZERO	Load on CTR = 0
	LOADBMODE	CC_CTR_ZERO	Load on CTR = 0
AQCTLA	PRD	AQ_CLEAR	
	CAU	AQ_SET	

Example 3. Configuration for Example in Figure 52

```
// Run Time (Note: Example execution of one run-time instance)
//=====
EPwm1Regs.CMPA.half.CMPA = 700;           // adjust duty for output EPWM1A
EPwm2Regs.CMPA.half.CMPA = 700;           // adjust duty for output EPWM2A
EPwm3Regs.CMPA.half.CMPA = 500;           // adjust duty for output EPWM3A
```

3.4 Controlling Multiple Buck Converters With Same Frequencies

If synchronization is a requirement, ePWM module 2 can be configured as a slave and can operate at integer multiple (N) frequencies of module 1. The sync signal from master to slave ensures these modules remain locked. Figure 53 shows such a configuration; Figure 54 shows the waveforms generated by the configuration.

Figure 53. Control of Four Buck Stages. (Note: $F_{PWM2} = N \times F_{PWM1}$)

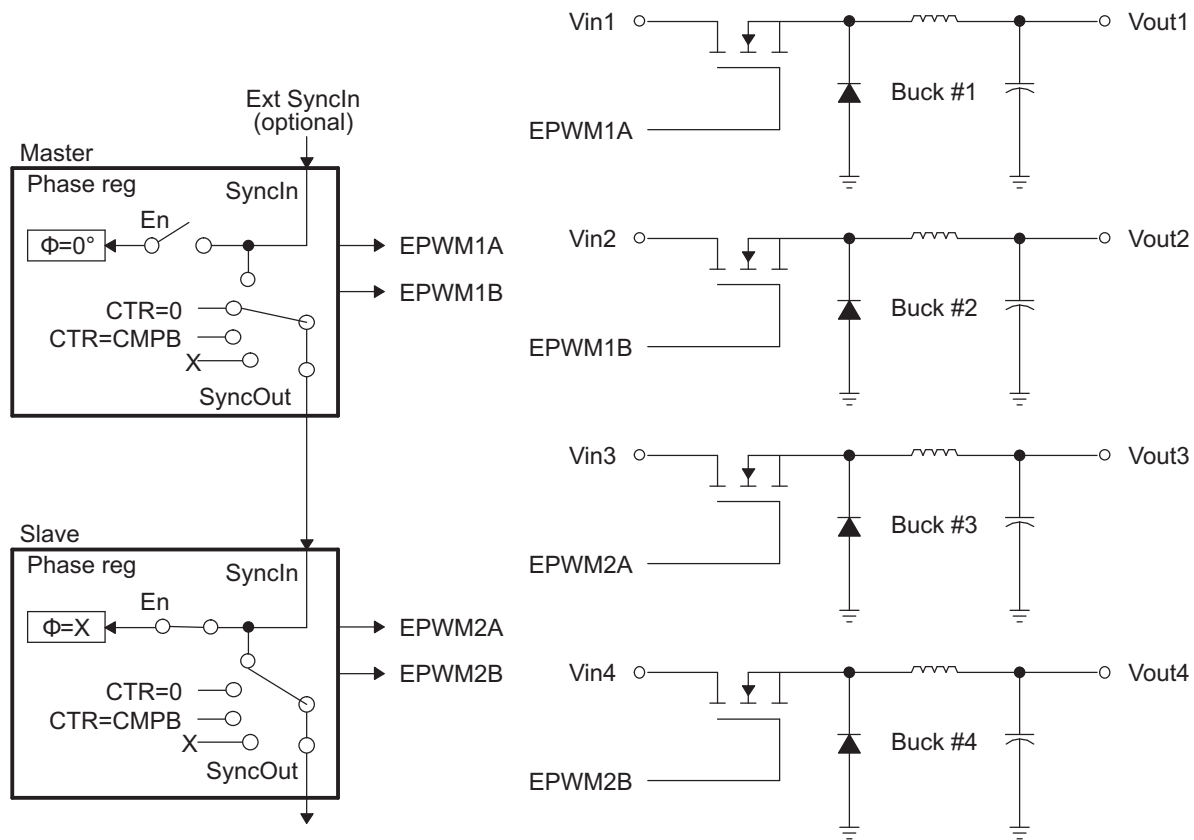

Figure 54. Buck Waveforms for Figure 53 (Note: $F_{PWM2} = F_{PWM1}$)

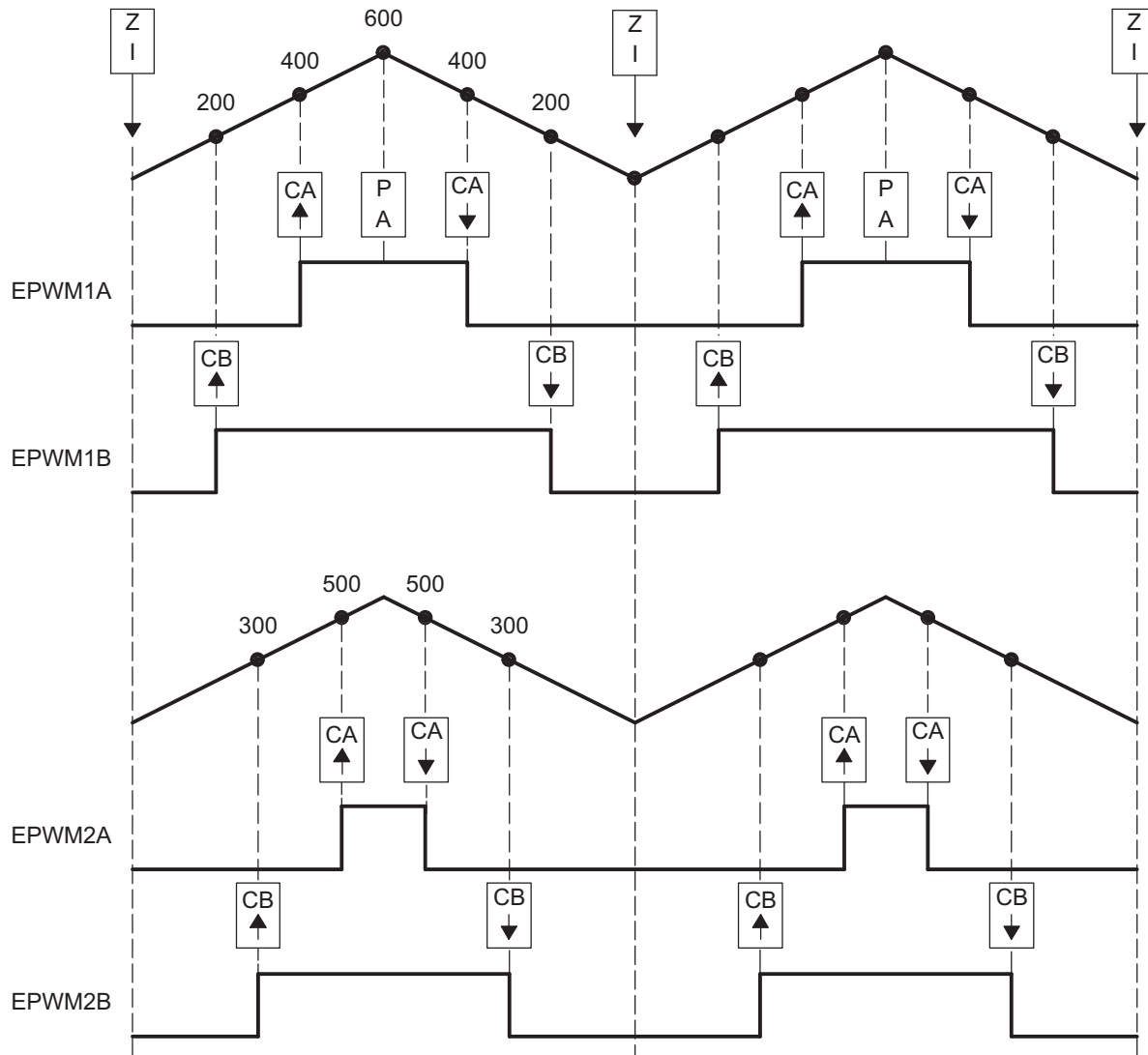

Table 38. EPWM1 Initialization for Figure 53

Register	Bit	Value	Comments
TBPRD	TBPRD	600 (258h)	Period = 1200 TBCLK counts
TBPHS	TBPHS	0	Clear Phase Register to 0
TBCTL	CTRMODE	TB_UPDOWN	
	PHSEN	TB_DISABLE	Phase loading disabled
	PRDL	TB_SHADOW	
	SYNCOSEL	TB_CTR_ZERO	Sync down-stream module
CMPCTL	SHDWAMODE	CC_SHADOW	
	SHDWBMODE	CC_SHADOW	
	LOADAMODE	CC_CTR_ZERO	Load on CTR = 0
	LOADBMODE	CC_CTR_ZERO	Load on CTR = 0
AQCTLA	CAU	AQ_SET	Set actions for EPWM1A
	CAD	AQ_CLEAR	
AQCTLB	CBU	AQ_SET	Set actions for EPWM1B
	CBD	AQ_CLEAR	

Table 39. EPWM2 Initialization for Figure 53

Register	Bit	Value	Comments
TBPRD	TBPRD	600 (258h)	Period = 1200 TBCLK counts
TBPHS	TBPHS	0	Clear Phase Register to 0
TBCTL	CTRMODE	TB_UPDOWN	
	PHSEN	TB_ENABLE	Phase loading enabled
	PRDL	TB_SHADOW	
	SYNCOSEL	TB_SYNC_IN	Sync flow-through
CMPCTL	SHDWAMODE	CC_SHADOW	
	SHDWBMODE	CC_SHADOW	
	LOADAMODE	CC_CTR_ZERO	Load on CTR = 0
	LOADBMODE	CC_CTR_ZERO	Load on CTR = 0
AQCTLA	CAU	AQ_SET	Set actions for EPWM2A
	CAD	AQ_CLEAR	
AQCTLB	CBU	AQ_SET	Set actions for EPWM2B
	CBD	AQ_CLEAR	

Example 4. Code Snippet for Configuration in Figure 53

```
// Run Time (Note: Example execution of one run-time instance)
//=====
EPwm1Regs.CMPA.half.CMPA = 400;      // adjust duty for output EPWM1A
EPwm1Regs.CMPB = 200;                // adjust duty for output EPWM1B
EPwm2Regs.CMPA.half.CMPA = 500;     // adjust duty for output EPWM2A
EPwm2Regs.CMPB = 300;                // adjust duty for output EPWM2B
```

3.5 Controlling Multiple Half H-Bridge (HHB) Converters

Topologies that require control of multiple switching elements can also be addressed with these same ePWM modules. It is possible to control a Half-H bridge stage with a single ePWM module. This control can be extended to multiple stages. Figure 55 shows control of two synchronized Half-H bridge stages where stage 2 can operate at integer multiple (N) frequencies of stage 1. Figure 56 shows the waveforms generated by the configuration shown in Figure 55.

Module 2 (slave) is configured for Sync flow-through; if required, this configuration allows for a third Half-H bridge to be controlled by PWM module 3 and also, most importantly, to remain in synchronization with master module 1.

Figure 55. Control of Two Half-H Bridge Stages ($F_{PWM2} = N \times F_{PWM1}$)

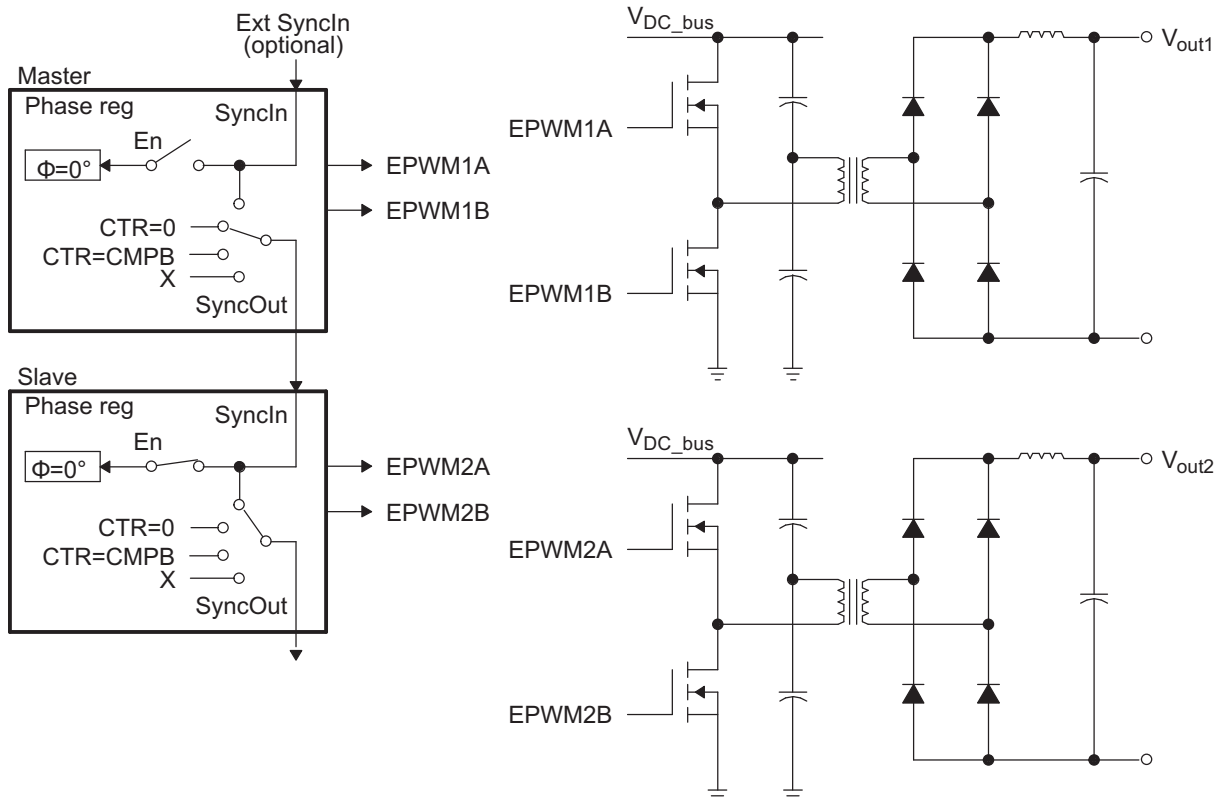

Figure 56. Half-H Bridge Waveforms for Figure 55 (Note: Here $F_{PWM2} = F_{PWM1}$)

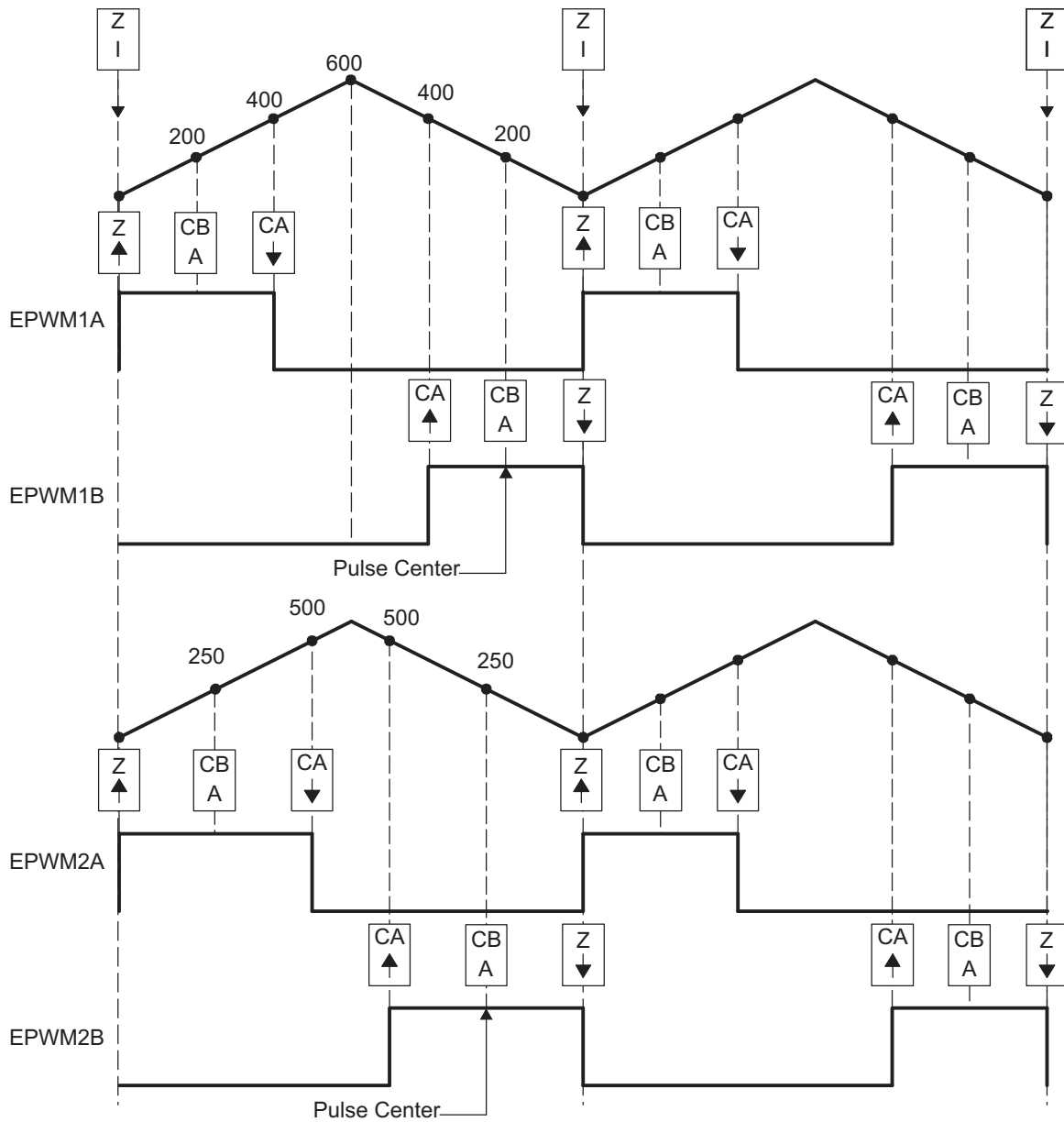

Table 40. EPWM1 Initialization for Figure 55

Register	Bit	Value	Comments
TBPRD	TBPRD	600 (258h)	Period = 1200 TBCLK counts
TBPHS	TBPHS	0	Clear Phase Register to 0
TBCTL	CTRMODE	TB_UPDOWN	
	PHSEN	TB_DISABLE	Phase loading disabled
	PRDL	TB_SHADOW	
	SYNCOSEL	TB_CTR_ZERO	Sync down-stream module
CMPCTL	SHDWAMODE	CC_SHADOW	
	SHDWBMODE	CC_SHADOW	
	LOADAMODE	CC_CTR_ZERO	Load on CTR = 0
	LOADBMODE	CC_CTR_ZERO	Load on CTR = 0
AQCTLA	ZRO	AQ_SET	Set actions for EPWM1A
	CAU	AQ_CLEAR	
AQCTLB	ZRO	AQ_CLEAR	Set actions for EPWM1B
	CAD	AQ_SET	

Table 41. EPWM2 Initialization for Figure 55

Register	Bit	Value	Comments
TBPRD	TBPRD	600 (258h)	Period = 1200 TBCLK counts
TBPHS	TBPHS	0	Clear Phase Register to 0
TBCTL	CTRMODE	TB_UPDOWN	
	PHSEN	TB_ENABLE	Phase loading enabled
	PRDL	TB_SHADOW	
	SYNCOSEL	TB_SYNC_IN	Sync flow-through
CMPCTL	SHDWAMODE	CC_SHADOW	
	SHDWBMODE	CC_SHADOW	
	LOADAMODE	CC_CTR_ZERO	Load on CTR = 0
	LOADBMODE	CC_CTR_ZERO	Load on CTR = 0
AQCTLA	ZRO	AQ_SET	Set actions for EPWM2A
	CAU	AQ_CLEAR	
AQCTLB	ZRO	AQ_CLEAR	Set actions for EPWM2B
	CAD	AQ_SET	

Example 5. Code Snippet for Configuration in Figure 55

```
// Run Time (Note: Example execution of one run-time instance)
//=====
EPwm1Regs.CMPA.half.CMPA = 400; // adjust duty for output EPWM1A
EPwm1Regs.CMPB = 200; // adjust duty for output EPWM1B
EPwm2Regs.CMPA.half.CMPA = 500; // adjust duty for output EPWM2A
EPwm2Regs.CMPB = 250; // adjust duty for output EPWM2B
```

3.6 Controlling Dual 3-Phase Inverters for Motors (ACI and PMSM)

The idea of multiple modules controlling a single power stage can be extended to the 3-phase Inverter case. In such a case, six switching elements can be controlled using three PWM modules, one for each leg of the inverter. Each leg must switch at the same frequency and all legs must be synchronized. A master + two slaves configuration can easily address this requirement. Figure 57 shows how six PWM modules can control two independent 3-phase Inverters; each running a motor.

As in the cases shown in the previous sections, we have a choice of running each inverter at a different frequency (module 1 and module 4 are masters as in Figure 57), or both inverters can be synchronized by using one master (module 1) and five slaves. In this case, the frequency of modules 4, 5, and 6 (all equal) can be integer multiples of the frequency for modules 1, 2, 3 (also all equal).

Figure 57. Control of Dual 3-Phase Inverter Stages as Is Commonly Used in Motor Control

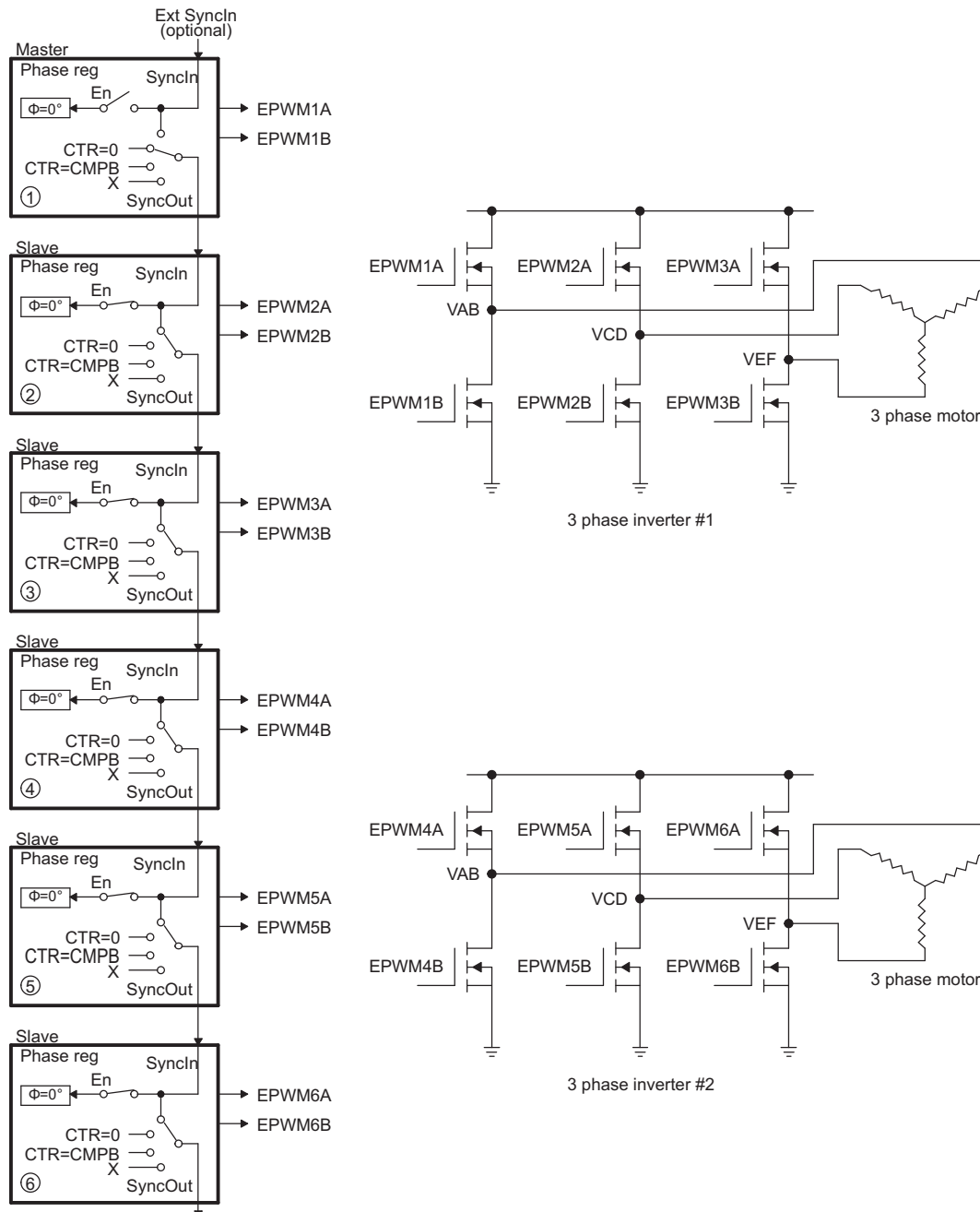

Figure 58. 3-Phase Inverter Waveforms for Figure 57 (Only One Inverter Shown)

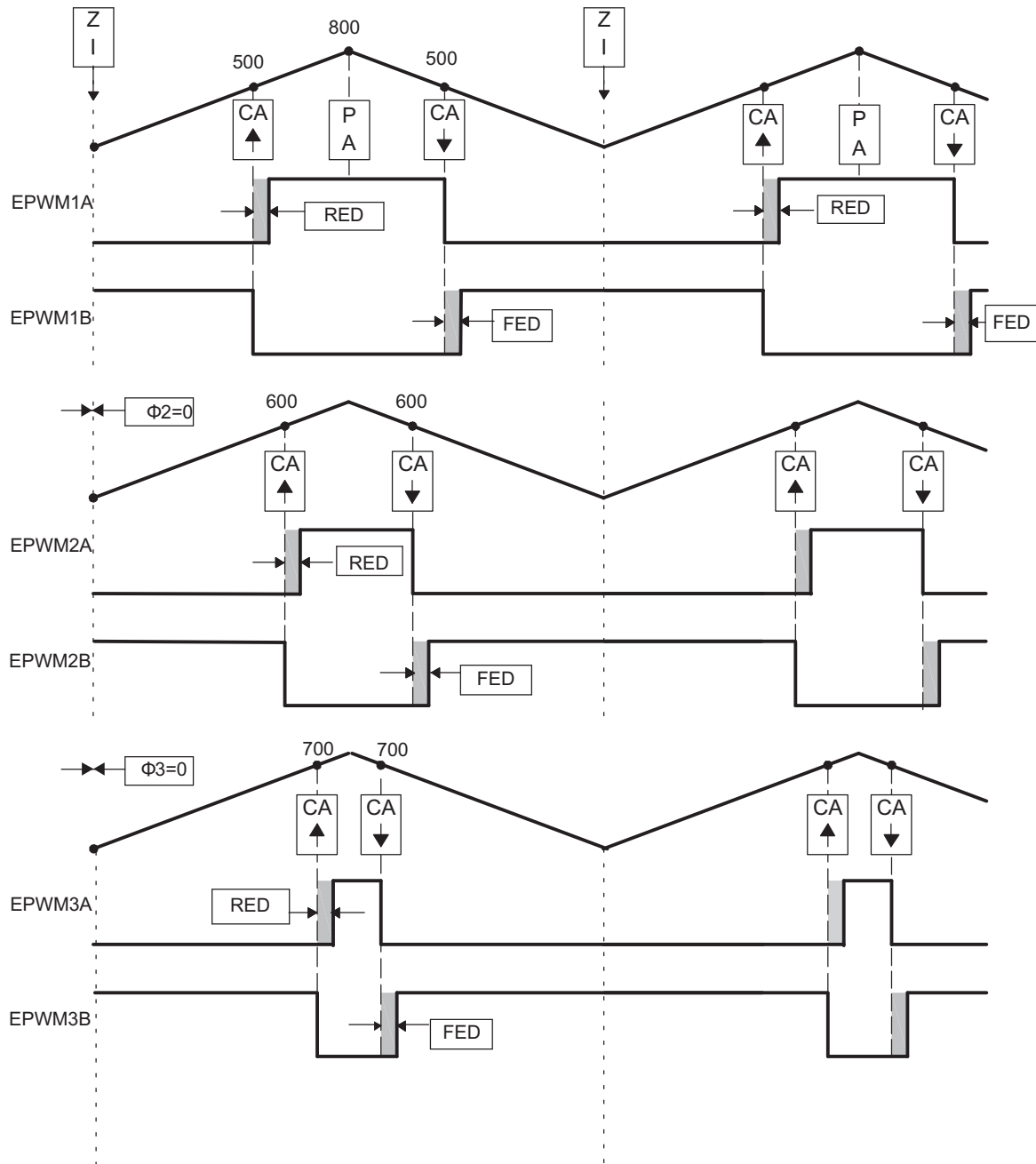

Table 42. EPWM1 Initialization for Figure 57

Register	Bit	Value	Comments
TBPRD	TBPRD	800 (320h)	Period = 1600 TBCLK counts
TBPHS	TBPHS	0	Clear Phase Register to 0
TBCTL	CTRMODE	TB_UPDOWN	
	PHSEN	TB_DISABLE	Phase loading disabled
	PRDL	TB_SHADOW	
	SYNCOSEL	TB_CTR_ZERO	Sync down-stream module
CMPCTL	SHDWAMODE	CC_SHADOW	
	SHDWBMODE	CC_SHADOW	
	LOADAMODE	CC_CTR_ZERO	Load on CTR = 0
	LOADBMODE	CC_CTR_ZERO	Load on CTR = 0
AQCTLA	CAU	AQ_SET	Set actions for EPWM1A
	CAD	AQ_CLEAR	
DBCTL	MODE	DB_FULL_ENABLE	Enable Dead-band module
	POLSEL	DB_ACTV_HIC	Active Hi complementary
DBFED	DBFED	50	FED = 50 TBCLKs
	DBRED	50	RED = 50 TBCLKs

Table 43. EPWM2 Initialization for Figure 57

Register	Bit	Value	Comments
TBPRD	TBPRD	800 (320h)	Period = 1600 TBCLK counts
TBPHS	TBPHS	0	Clear Phase Register to 0
TBCTL	CTRMODE	TB_UPDOWN	
	PHSEN	TB_ENABLE	Slave module
	PRDL	TB_SHADOW	
	SYNCOSEL	TB_SYNC_IN	Sync flow-through
CMPCTL	SHDWAMODE	CC_SHADOW	
	SHDWBMODE	CC_SHADOW	
	LOADAMODE	CC_CTR_ZERO	Load on CTR = 0
	LOADBMODE	CC_CTR_ZERO	Load on CTR = 0
AQCTLA	CAU	AQ_SET	Set actions for EPWM2A
	CAD	AQ_CLEAR	
DBCTL	MODE	DB_FULL_ENABLE	Enable Dead-band module
	POLSEL	DB_ACTV_HIC	Active Hi complementary
DBFED	DBFED	50	FED = 50 TBCLKs
	DBRED	50	RED = 50 TBCLKs

Table 44. EPWM3 Initialization for Figure 57

Register	Bit	Value	Comments
TBPRD	TBPRD	800 (320h)	Period = 1600 TBCLK counts
TBPHS	TBPHS	0	Clear Phase Register to 0
TBCTL	CTRMODE	TB_UPDOWN	Slave module
	PHSEN	TB_ENABLE	
	PRDL	TB_SHADOW	
	SYNCOSEL	TB_SYNC_IN	
CMPCTL	SHDWAMODE	CC_SHADOW	Load on CTR = 0
	SHDWBMODE	CC_SHADOW	
	LOADAMODE	CC_CTR_ZERO	
	LOADBMODE	CC_CTR_ZERO	
AQCTLA	CAU	AQ_SET	Set actions for EPWM3A
	CAD	AQ_CLEAR	
DBCTL	MODE	DB_FULL_ENABLE	Enable Dead-band module
	POLSEL	DB_ACTV_HIC	Active Hi complementary
DBFED	DBFED	50	FED = 50 TBCLKs
	DBRED	50	RED = 50 TBCLKs

Example 6. Code Snippet for Configuration in Figure 57

```
// Run Time (Note: Example execution of one run-time instance)
//=====
EPwm1Regs.CMPA.half.CMPA = 500; // adjust duty for output EPWM1A
EPwm2Regs.CMPA.half.CMPA = 600; // adjust duty for output EPWM2A
EPwm3Regs.CMPA.half.CMPA = 700; // adjust duty for output EPWM3A
```

3.7 Practical Applications Using Phase Control Between PWM Modules

So far, none of the examples have made use of the phase register (TBPHS). It has either been set to zero or its value has been a don't care. However, by programming appropriate values into TBPHS, multiple PWM modules can address another class of power topologies that rely on phase relationship between legs (or stages) for correct operation. As described in the TB module section, a PWM module can be configured to allow a SyncIn pulse to cause the TBPHS register to be loaded into the TBCNT register. To illustrate this concept, Figure 59 shows a master and slave module with a phase relationship of 120°, that is, the slave leads the master.

Figure 59. Configuring Two PWM Modules for Phase Control

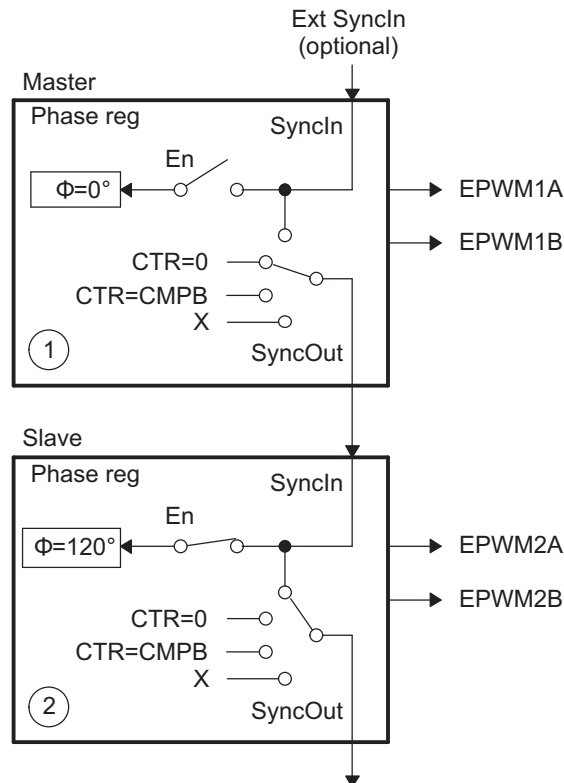
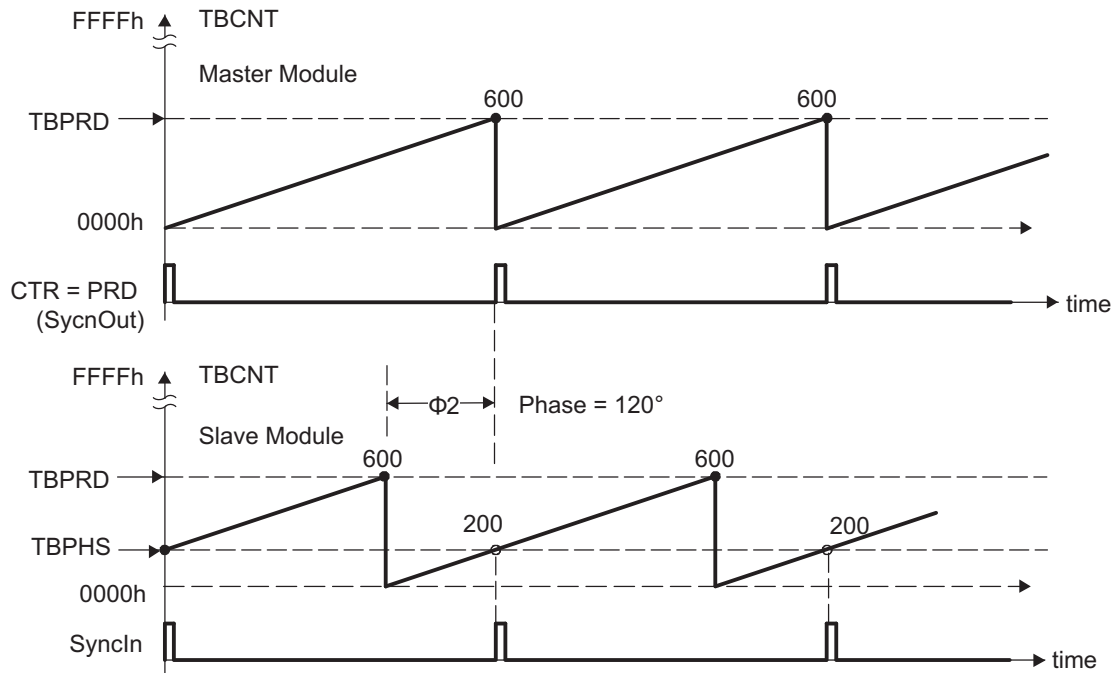

Figure 60 shows the associated timing waveforms for this configuration. Here, TBPRD = 600 for both master and slave. For the slave, TBPHS = 200 ($200/600 \times 360^\circ = 120^\circ$). Whenever the master generates a SyncIn pulse (CTR = PRD), the value of TBPHS = 200 is loaded into the slave TBCNT register so the slave time-base is always leading the master's time-base by 120°.

Figure 60. Timing Waveforms Associated With Phase Control Between 2 Modules

3.8 Controlling a 3-Phase Interleaved DC/DC Converter

A popular power topology that makes use of phase-offset between modules is shown in [Figure 61](#). This system uses three PWM modules, with module 1 configured as the master. To work, the phase relationship between adjacent modules must be $F = 120^\circ$. This is achieved by setting the slave TBPHS registers 2 and 3 with values of 1/3 and 2/3 of the period value, respectively. For example, if the period register is loaded with a value of 600 counts, then TBPHS (slave 2) = 200 and TBPHS (slave 3) = 400. Both slave modules are synchronized to the master 1 module.

This concept can be extended to four or more phases, by setting the TBPHS values appropriately. The following formula gives the TBPHS values for N phases:

$$\text{TBPHS}(N,M) = (\text{TBPRD}/N) \times (M - 1)$$

Where:

N = number of phases

M = PWM module number

For example, for the 3-phase case (N = 3), TBPRD = 600,

$$\text{TBPHS}(3,2) = (600/3) \times (2 - 1) = 200 \times 1 = 200 \text{ (Phase value for Slave module 2)}$$

$$\text{TBPHS}(3,3) = (600/3) \times (3 - 1) = 200 \times 2 = 400 \text{ (Phase value for Slave module 3)}$$

[Figure 62](#) shows the waveforms for the configuration in [Figure 61](#).

Figure 61. Control of a 3-Phase Interleaved DC/DC Converter

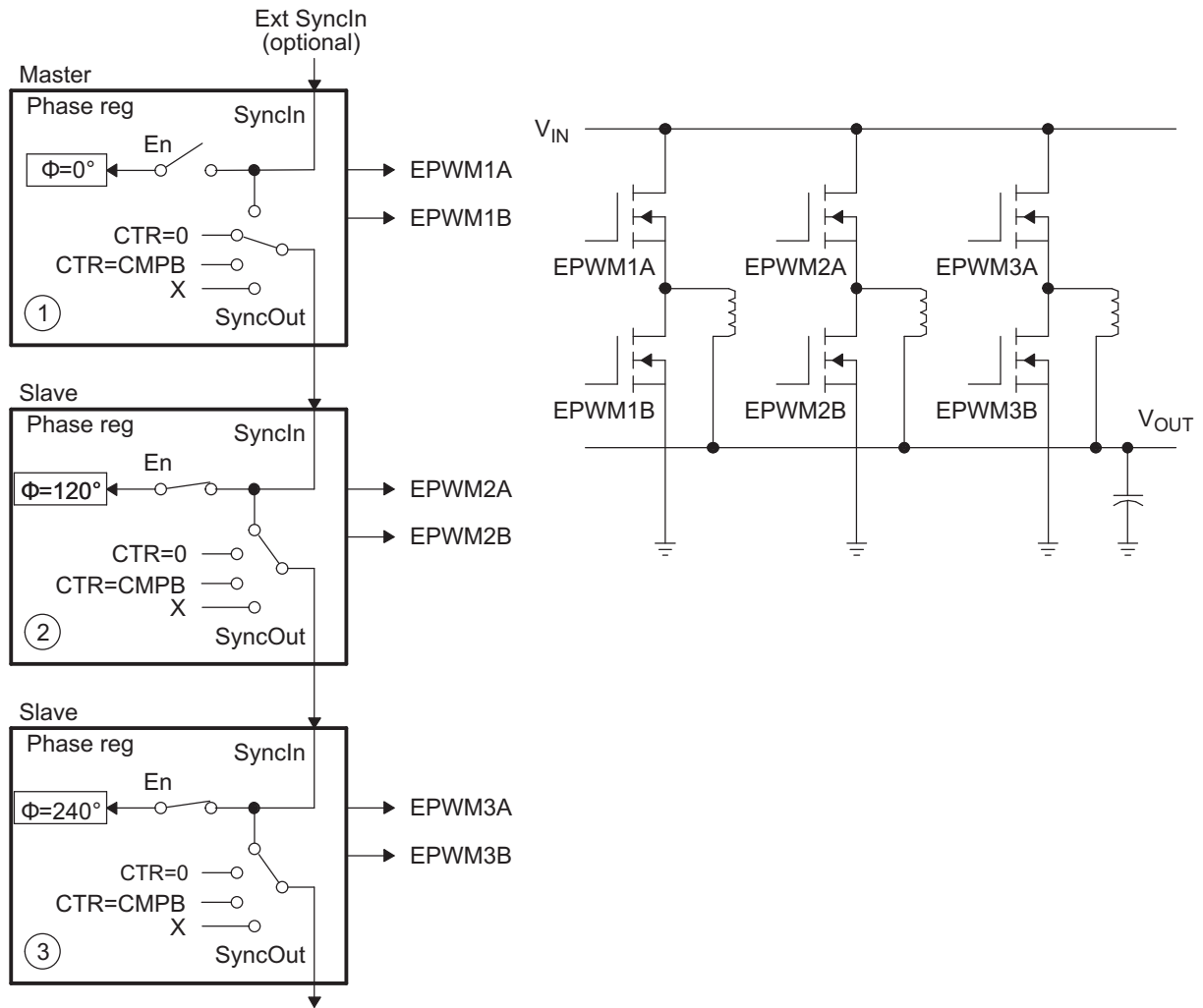

Figure 62. 3-Phase Interleaved DC/DC Converter Waveforms for Figure 61

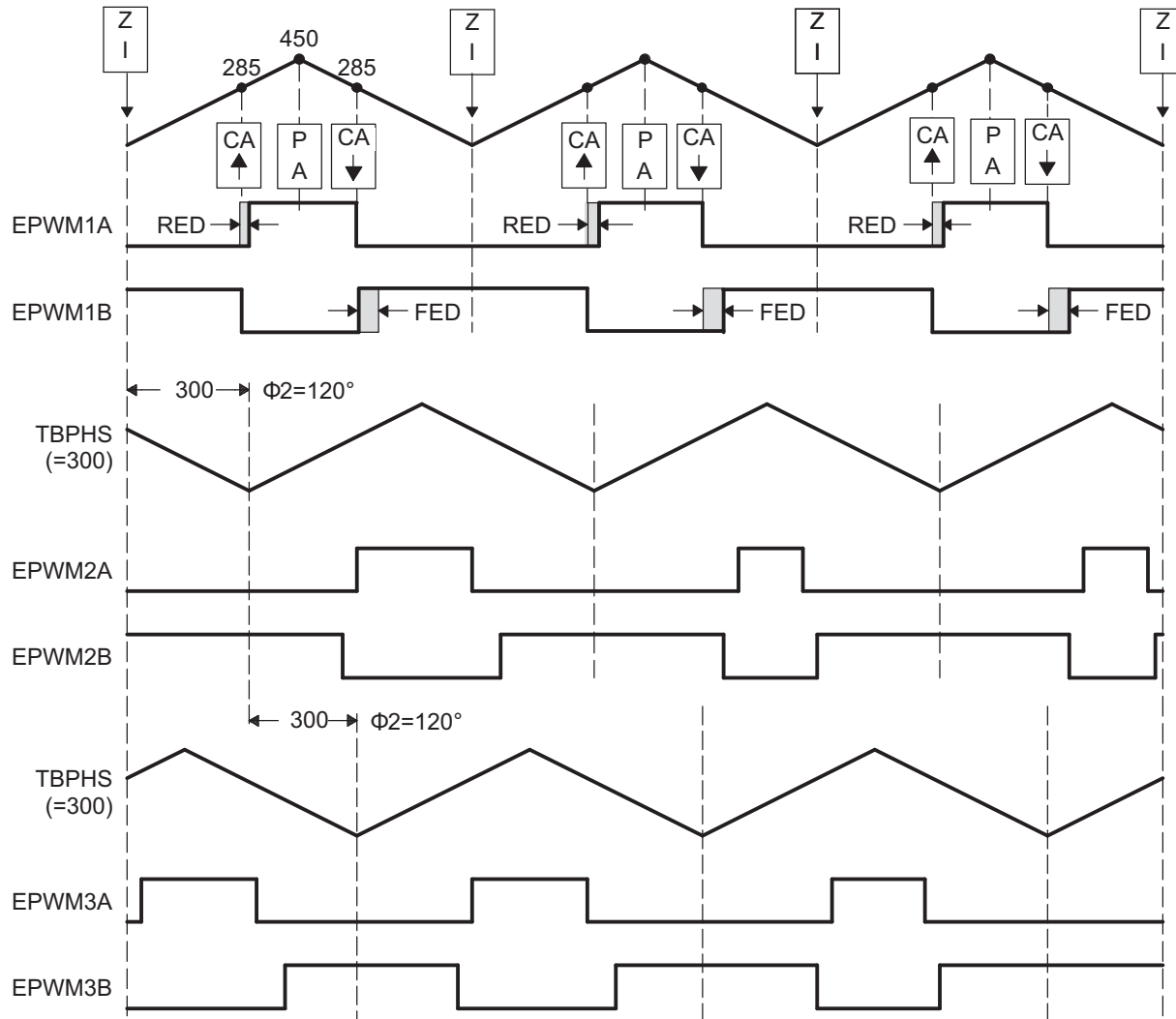

Table 45. EPWM1 Initialization for Figure 61

Register	Bit	Value	Comments
TBPRD	TBPRD	450 (1C2h)	Period = 900 TBCLK counts
TBPHS	TBPHS	0	Clear Phase Register to 0
TBCTL	CTRMODE	TB_UPDOWN	
	PHSEN	TB_DISABLE	Phase loading disabled
	PRDL	TB_SHADOW	
	SYNCOSEL	TB_CTR_ZERO	Sync down-stream module
CMPCTL	SHDWAMODE	CC_SHADOW	
	SHDWBMODE	CC_SHADOW	
	LOADAMODE	CC_CTR_ZERO	Load on CTR = 0
	LOADBMODE	CC_CTR_ZERO	Load on CTR = 0
AQCTLA	CAU	AQ_SET	Set actions for EPWM1A
	CAD	AQ_CLEAR	
DBCTL	MODE	DB_FULL_ENABLE	Enable Dead-band module
	POLSEL	DB_ACTV_HIC	Active Hi complementary
DBFED	DBFED	20	FED = 20 TBCLKs
	DBRED	20	RED = 20 TBCLKs

Table 46. EPWM2 Initialization for Figure 61

Register	Bit	Value	Comments
TBPRD	TBPRD	450 (1C2h)	Period = 900 TBCLK counts
TBPHS	TBPHS	300	Phase = $(300/900) \times 360 = 120^\circ$
TBCTL	CTRMODE	TB_UPDOWN	
	PHSEN	TB_ENABLE	Slave module
	PRDL	TB_SHADOW	
	SYNCOSEL	TB_SYNC_IN	Sync flow-through
	PHSDIR	TB_DOWN	Count DOWN on sync
CMPCTL	SHDWAMODE	CC_SHADOW	
	SHDWBMODE	CC_SHADOW	
	LOADAMODE	CC_CTR_ZERO	Load on CTR = 0
	LOADBMODE	CC_CTR_ZERO	Load on CTR = 0
AQCTLA	CAU	AQ_SET	Set actions for EPWM2A
	CAD	AQ_CLEAR	
DBCTL	MODE	DB_FULL_ENABLE	Enable Dead-band module
	POLSEL	DB_ACTV_HIC	Active Hi complementary
DBFED	DBFED	20	FED = 20 TBCLKs
	DBRED	20	RED = 20 TBCLKs

Table 47. EPWM3 Initialization for Figure 61

Register	Bit	Value	Comments
TBPRD	TBPRD	450 (1C2h)	Period = 900 TBCLK counts
TBPHS	TBPHS	300	Phase = (300/900) x 360 = 120°
TBCTL	CTRMODE	TB_UPDOWN	
	PHSEN	TB_ENABLE	Slave module
	PRDL	TB_SHADOW	
	SYNCOSEL	TB_SYNC_IN	Sync flow-through
	PHSDIR	TB_UP	Count UP on sync
CMPCTL	SHDWAMODE	CC_SHADOW	
	SHDWBMODE	CC_SHADOW	
	LOADAMODE	CC_CTR_ZERO	Load on CTR = 0
	LOADBMODE	CC_CTR_ZERO	Load on CTR = 0
AQCTLA	CAU	AQ_SET	Set actions for EPWM3A
	CAD	AQ_CLEAR	
DBCTL	MODE	DB_FULL_ENABLE	Enable Dead-band module
	POLSEL	DB_ACTV_HIC	Active Hi complementary
DBFED	DBFED	20	FED = 20 TBCLKs
	DBRED	20	RED = 20 TBCLKs

Example 7. Code Snippet for Configuration in Figure 61

```
// Run Time (Note: Example execution of one run-time instance)
//=====
EPwm1Regs.CMPA.half.CMPA = 285;           // adjust duty for output EPWM1A
EPwm2Regs.CMPA.half.CMPA = 285;           // adjust duty for output EPWM2A
EPwm3Regs.CMPA.half.CMPA = 285;           // adjust duty for output EPWM3A
```

3.9 Controlling Zero Voltage Switched Full Bridge (ZVSFB) Converter

The example given in Figure 63 assumes a static or constant phase relationship between legs (modules). In such a case, control is achieved by modulating the duty cycle. It is also possible to dynamically change the phase value on a cycle-by-cycle basis. This feature lends itself to controlling a class of power topologies known as *phase-shifted full bridge*, or *zero voltage switched full bridge*. Here the controlled parameter is not duty cycle (this is kept constant at approximately 50 percent); instead it is the phase relationship between legs. Such a system can be implemented by allocating the resources of two PWM modules to control a single power stage, which in turn requires control of four switching elements. Figure 64 shows a master/slave module combination synchronized together to control a full H-bridge. In this case, both master and slave modules are required to switch at the same PWM frequency. The phase is controlled by using the slave's phase register (TBPHS). The master's phase register is not used and therefore can be initialized to zero.

Figure 63. Controlling a Full-H Bridge Stage ($F_{PWM2} = F_{PWM1}$)

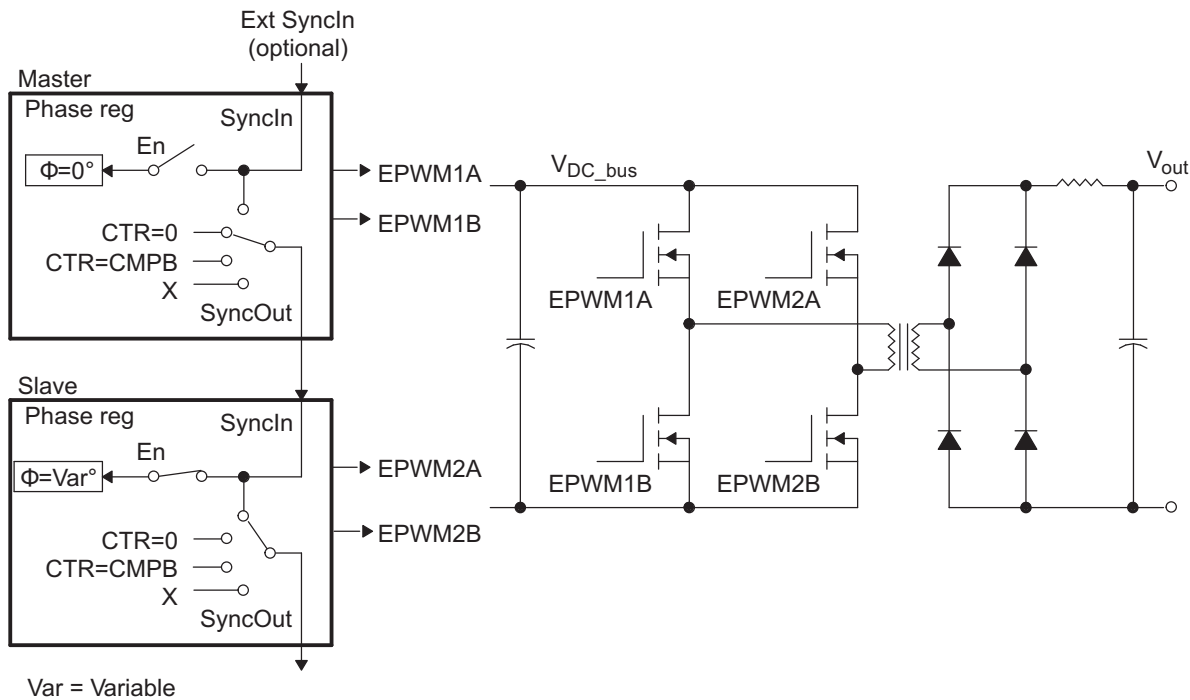

Figure 64. ZVS Full-H Bridge Waveforms

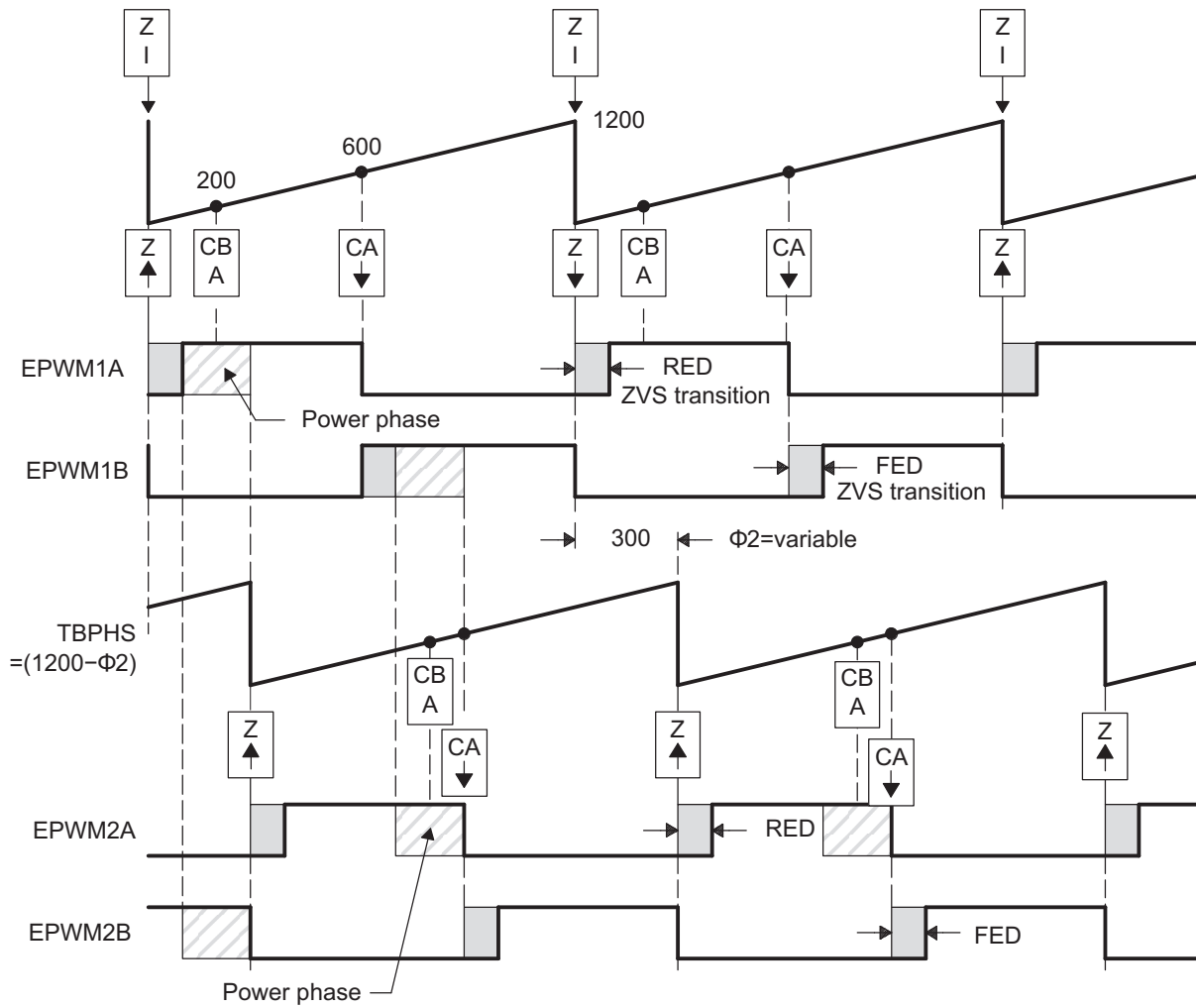

Table 48. EPWM1 Initialization for Figure 63

Register	Bit	Value	Comments
TBPRD	TBPRD	1200 (4B0h)	Period = 1201 TBCLK counts
TBPHS	TBPHS	0	Clear Phase Register to 0
TBCTL	CTRMODE	TB_UP	
	PHSEN	TB_DISABLE	Phase loading disabled
	PRDL	TB_SHADOW	
	SYNCOSEL	TB_CTR_ZERO	Sync down-stream module
CMPA	CMPA	600 (258h)	Set 50% duty for EPWM1A
CMPCTL	SHDWAMODE	CC_SHADOW	
	SHDWBMODE	CC_SHADOW	
	LOADAMODE	CC_CTR_ZERO	Load on CTR = 0
	LOADBMODE	CC_CTR_ZERO	Load on CTR = 0
AQCTLA	ZRO	AQ_SET	Set actions for EPWM1A
	CAU	AQ_CLEAR	
DBCTL	MODE	DB_FULL_ENABLE	Enable Dead-band module
	POLSEL	DB_ACTV_HIC	Active Hi complementary
DBFED	DBFED	50	FED = 50 TBCLKs
	DBRED	70	RED = 70 TBCLKs

Table 49. EPWM2 Initialization for Figure 63

Register	Bit	Value	Comments
TBPRD	TBPRD	1200 (4B0h)	Period = 1201 TBCLK counts
TBPHS	TBPHS	0	Clear Phase Register to 0
TBCTL	CTRMODE	TB_UP	
	PHSEN	TB_ENABLE	Slave module
	PRDL	TB_SHADOW	
	SYNCOSEL	TB_SYNC_IN	Sync flow-through
CMPA	CMPA	600 (258h)	Set 50% duty for EPWM2A
CMPCTL	SHDWAMODE	CC_SHADOW	
	SHDWBMODE	CC_SHADOW	
	LOADAMODE	CC_CTR_ZERO	Load on CTR = 0
	LOADBMODE	CC_CTR_ZERO	Load on CTR = 0
AQCTLA	ZRO	AQ_SET	Set actions for EPWM2A
	CAU	AQ_CLEAR	
DBCTL	MODE	DB_FULL_ENABLE	Enable Dead-band module
	POLSEL	DB_ACTV_HIC	Active Hi complementary
DBFED	DBFED	30	FED = 30 TBCLKs
	DBRED	40	RED = 40 TBCLKs

Example 8. Code Snippet for Configuration in Figure 63

```
// Run Time (Note: Example execution of one run-time instance)
//=====
EPwm2Regs.TBPHS = 1200-300;           // Set Phase reg to 300/1200 * 360 = 90 deg
EPwm1Regs.DBFED = FED1_NewValue;     // Update ZVS transition interval
EPwm1Regs.DBRED = RED1_NewValue;     // Update ZVS transition interval
EPwm2Regs.DBFED = FED2_NewValue;     // Update ZVS transition interval
EPwm2Regs.DBRED = RED2_NewValue;     // Update ZVS transition interval
```

4 Registers

This section includes the registers for the submodules.

Table 50. Submodule Registers

Submodule	Section
Time-Base Submodule Registers	Section 4.1
Counter-Compare Submodule Registers	Section 4.2
Action-Qualifier Submodule Registers	Section 4.3
Dead-Band Generator Submodule Registers	Section 4.4
PWM-Chopper Submodule Registers	Section 4.5
Trip-Zone Submodule Registers	Section 4.6
Event-Trigger Submodule Registers	Section 4.7
High-Resolution PWM Registers	Section 4.8

4.1 Time-Base Submodule Registers

[Table 51](#) lists the memory-mapped registers for the time-base submodule. See your device-specific data manual for the memory address of these registers. All other register offset addresses not listed in [Table 51](#) should be considered as reserved locations and the register contents should not be modified.

Table 51. Time-Base Submodule Registers

Offset	Acronym	Register Description	Section
0h	TBCTL	Time-Base Control Register	Section 4.1.1
2h	TBSTS	Time-Base Status Register	Section 4.1.2
4h	TBPHSHR	Time-Base Phase High-Resolution Register ⁽¹⁾	Section 4.8.1
6h	TBPHS	Time-Base Phase Register	Section 4.1.3
8h	TBCNT	Time-Base Counter Register	Section 4.1.4
Ah	TBPRD	Time-Base Period Register	Section 4.1.5

⁽¹⁾ This register is only available on ePWM instances that include the high-resolution PWM (HRPWM) extension; otherwise, this location is reserved. See your device-specific data manual to determine which instances include the HRPWM.

4.1.1 Time-Base Control Register (TBCTL)

The time-base control register (TBCTL) is shown in [Figure 65](#) and described in [Table 52](#).

Figure 65. Time-Base Control Register (TBCTL)

15	14	13	12	10	9	8
FREE, SOFT		PHSDIR	CLKDIV		HSPCLKDIV	
R/W-0		R/W-0	R/W-0		R/W-0	
7	6	5	4	3	2	1 0
HSPCLKDIV	SWFSYNC	SYNCOSEL		PRDL	PHSEN	CTRM
R/W-1	R/W-0	R/W-0		R/W-0	R/W-0	R/W-3h

LEGEND: R/W = Read/Write; R = Read only; -n = value after reset

Table 52. Time-Base Control Register (TBCTL) Field Descriptions

Bit	Field	Value	Description
15-14	FREE, SOFT	0-3h 0 1h 2h-3h	Emulation Mode Bits. These bits select the behavior of the ePWM time-base counter during emulation events: 0 Stop after the next time-base counter increment or decrement 1h Stop when counter completes a whole cycle: <ul style="list-style-type: none"> Up-count mode: stop when the time-base counter = period (TBCNT = TBPRD) Down-count mode: stop when the time-base counter = 0000 (TBCNT = 0000h) Up-down-count mode: stop when the time-base counter = 0000 (TBCNT = 0000h) 2h-3h Free run
13	PHSDIR	0 1	Phase Direction Bit. This bit is only used when the time-base counter is configured in the up-down-count mode. The PHSDIR bit indicates the direction the time-base counter (TBCNT) will count after a synchronization event occurs and a new phase value is loaded from the phase (TBPHS) register. This is irrespective of the direction of the counter before the synchronization event.. In the up-count and down-count modes this bit is ignored. 0 Count down after the synchronization event. 1 Count up after the synchronization event.
12:10	CLKDIV	0-7h 0 1h 2h 3h 4h 5h 6h 7h	Time-base Clock Prescale Bits. These bits determine part of the time-base clock prescale value. $TBCLK = SYCLKOUT / (HSPCLKDIV \times CLKDIV)$ 0 /1 (default on reset) 1h /2 2h /4 3h /8 4h /16 5h /32 6h /64 7h /128
9-7	HSPCLKDIV	0-7h 0 1h 2h 3h 4h 5h 6h 7h	High-Speed Time-base Clock Prescale Bits. These bits determine part of the time-base clock prescale value. $TBCLK = SYCLKOUT / (HSPCLKDIV \times CLKDIV)$ This divisor emulates the HSPCLK in the TMS320x281x system as used on the Event Manager (EV) peripheral. 0 /1 1h /2 (default on reset) 2h /4 3h /6 4h /8 5h /10 6h /12 7h /14
6	SWFSYNC	0 1	Software Forced Synchronization Pulse 0 Writing a 0 has no effect and reads always return a 0. 1 Writing a 1 forces a one-time synchronization pulse to be generated. This event is ORed with the EPWMxSYNCl input of the ePWM module. SWFSYNC is valid (operates) only when EPWMxSYNCl is selected by SYNCOSSEL = 00.
5-4	SYNCOSSEL	0-3h 0 1h 2h 3h	Synchronization Output Select. These bits select the source of the EPWMxSYNCO signal. 0 EPWMxSYNCO: 1h CTR = 0: Time-base counter equal to zero (TBCNT = 0000h) 2h CTR = CMPB : Time-base counter equal to counter-compare B (TBCNT = CMPB) 3h Disable EPWMxSYNCO signal

Table 52. Time-Base Control Register (TBCTL) Field Descriptions (continued)

Bit	Field	Value	Description
3	PRDL	0 1	Active Period Register Load From Shadow Register Select The period register (TBPRD) is loaded from its shadow register when the time-base counter, TBCNT, is equal to zero. A write or read to the TBPRD register accesses the shadow register. Load the TBPRD register immediately without using a shadow register. A write or read to the TBPRD register directly accesses the active register.
2	PHSEN	0 1	Counter Register Load From Phase Register Enable Do not load the time-base counter (TBCNT) from the time-base phase register (TBPHS) Load the time-base counter with the phase register when an EPWMxSYNCl input signal occurs or when a software synchronization is forced by the SWFSYNC bit.
1-0	CTRM	0-3h 0 1h 2h 3h	Counter Mode. The time-base counter mode is normally configured once and not changed during normal operation. If you change the mode of the counter, the change will take effect at the next TBCLK edge and the current counter value shall increment or decrement from the value before the mode change. These bits set the time-base counter mode of operation as follows: Up-count mode Down-count mode Up-down-count mode Stop-freeze counter operation (default on reset)

4.1.2 Time-Base Status Register (TBSTS)

The time-base status register (TBSTS) is shown in [Figure 66](#) and described in [Table 53](#).

Figure 66. Time-Base Status Register (TBSTS)

15	3	2	1	0
Reserved	CTRMAX	SYNCl	CTRDIR	
R-0	R/W1C-0	R/W1C-0	R-1	

LEGEND: R/W = Read/Write; R/W1C = Read/Write 1 to clear; -n = value after reset

Table 53. Time-Base Status Register (TBSTS) Field Descriptions

Bit	Field	Value	Description
15-3	Reserved	0	Reserved
2	CTRMAX	0 1	Time-Base Counter Max Latched Status Bit Reading a 0 indicates the time-base counter never reached its maximum value. Writing a 0 will have no effect. Reading a 1 on this bit indicates that the time-base counter reached the max value 0xFFFF. Writing a 1 to this bit will clear the latched event.
1	SYNCl	0 1	Input Synchronization Latched Status Bit Writing a 0 will have no effect. Reading a 0 indicates no external synchronization event has occurred. Reading a 1 on this bit indicates that an external synchronization event has occurred (EPWMxSYNCl). Writing a 1 to this bit will clear the latched event.
0	CTRDIR	0 1	Time-Base Counter Direction Status Bit. At reset, the counter is frozen; therefore, this bit has no meaning. To make this bit meaningful, you must first set the appropriate mode via TBCTL[CTRM]. Time-Base Counter is currently counting down. Time-Base Counter is currently counting up.

4.1.3 Time-Base Phase Register (TBPHS)

The time-base phase register (TBPHS) is shown in [Figure 67](#) and described in [Table 54](#).

Figure 67. Time-Base Phase Register (TBPHS)

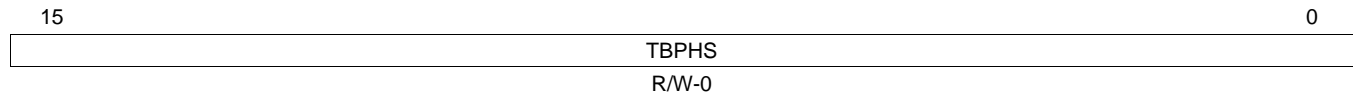

LEGEND: R/W = Read/Write; -n = value after reset

Table 54. Time-Base Phase Register (TBPHS) Field Descriptions

Bits	Name	Value	Description
15-0	TBPHS	0-FFFFh	<p>These bits set time-base counter phase of the selected ePWM relative to the time-base that is supplying the synchronization input signal.</p> <ul style="list-style-type: none"> If TBCTL[PHSEN] = 0, then the synchronization event is ignored and the time-base counter is not loaded with the phase. If TBCTL[PHSEN] = 1, then the time-base counter (TBCNT) will be loaded with the phase (TBPHS) when a synchronization event occurs. The synchronization event can be initiated by the input synchronization signal (EPWMxSYNCI) or by a software forced synchronization.

4.1.4 Time-Base Counter Register (TBCNT)

The time-base counter register (TBCNT) is shown in [Figure 68](#) and described in [Table 55](#).

Figure 68. Time-Base Counter Register (TBCNT)

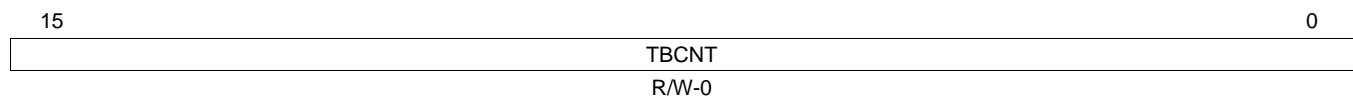

LEGEND: R/W = Read/Write; -n = value after reset

Table 55. Time-Base Counter Register (TBCNT) Field Descriptions

Bits	Name	Value	Description
15-0	TBCNT	0-FFFFh	<p>Reading these bits gives the current time-base counter value.</p> <p>Writing to these bits sets the current time-base counter value. The update happens as soon as the write occurs; the write is NOT synchronized to the time-base clock (TBCLK) and the register is not shadowed.</p>

4.1.5 Time-Base Period Register (TBPRD)

The time-base period register (TBPRD) is shown in [Figure 69](#) and described in [Table 56](#).

Figure 69. Time-Base Period Register (TBPRD)

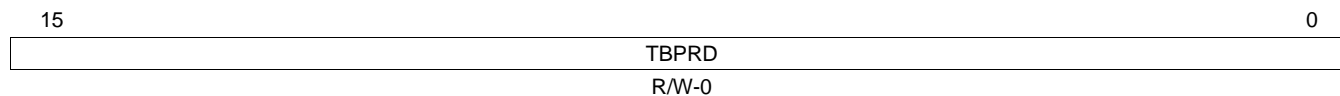

LEGEND: R/W = Read/Write; -n = value after reset

Table 56. Time-Base Period Register (TBPRD) Field Descriptions

Bits	Name	Value	Description
15-0	TBPRD	0-FFFFh	<p>These bits determine the period of the time-base counter. This sets the PWM frequency. Shadowing of this register is enabled and disabled by the TBCTL[PRDLD] bit. By default this register is shadowed.</p> <ul style="list-style-type: none"> If TBCTL[PRDLD] = 0, then the shadow is enabled and any write or read will automatically go to the shadow register. In this case, the active register will be loaded from the shadow register when the time-base counter equals zero. If TBCTL[PRDLD] = 1, then the shadow is disabled and any write or read will go directly to the active register, that is the register actively controlling the hardware. The active and shadow registers share the same memory map address.

4.2 Counter-Compare Submodule Registers

[Table 57](#) lists the memory-mapped registers for the counter-compare submodule. See your device-specific data manual for the memory address of these registers. All other register offset addresses not listed in [Table 57](#) should be considered as reserved locations and the register contents should not be modified.

Table 57. Counter-Compare Submodule Registers

Offset	Acronym	Register Description	Section
Eh	CMPCTL	Counter-Compare Control Register	Section 4.2.1
10h	CMPAHR	Counter-Compare A High-Resolution Register ⁽¹⁾	Section 4.8.2
12h	CMPA	Counter-Compare A Register	Section 4.2.2
14h	CMPB	Counter-Compare B Register	Section 4.2.3

⁽¹⁾ This register is only available on ePWM instances that include the high-resolution PWM (HRPWM) extension; otherwise, this location is reserved. See your device-specific data manual to determine which instances include the HRPWM.

4.2.1 Counter-Compare Control Register (CMPCTL)

The counter-compare control register (CMPCTL) is shown in [Figure 70](#) and described in [Table 58](#).

Figure 70. Counter-Compare Control Register (CMPCTL)

15				10			9		8	
Reserved							SHDWBFULL	SHDWAFULL		
R-0							R-0		R-0	
7		6	5	4	3	2		1	0	
Reserved		SHDWBMODE	Reserved	SHDWAMODE	LOADBMODE		LOADAMODE		LOADAMODE	
R-0		R/W-0	R-0	R/W-0	R/W-0		R/W-0		R/W-0	

LEGEND: R/W = Read/Write; R = Read only; -n = value after reset

Table 58. Counter-Compare Control Register (CMPCTL) Field Descriptions

Bits	Name	Value	Description
15-10	Reserved	0	Reserved
9	SHDWBFULL	0 1	Counter-compare B (CMPB) Shadow Register Full Status Flag. This bit self clears once a load-strobe occurs. 0 CMPB shadow FIFO not full yet 1 Indicates the CMPB shadow FIFO is full; a CPU write will overwrite current shadow value.
8	SHDWAFULL	0 1	Counter-compare A (CMPA) Shadow Register Full Status Flag. The flag bit is set when a 32-bit write to CMPA:CMPAHR register or a 16-bit write to CMPA register is made. A 16-bit write to CMPAHR register will not affect the flag. This bit self clears once a load-strobe occurs. 0 CMPA shadow FIFO not full yet 1 Indicates the CMPA shadow FIFO is full, a CPU write will overwrite the current shadow value.
7	Reserved	0	Reserved
6	SHDWBMODE	0 1	Counter-compare B (CMPB) Register Operating Mode 0 Shadow mode. Operates as a double buffer. All writes via the CPU access the shadow register. 1 Immediate mode. Only the active compare B register is used. All writes and reads directly access the active register for immediate compare action.
5	Reserved		Reserved
4	SHDWAMODE	0 1	Counter-compare A (CMPA) Register Operating Mode 0 Shadow mode. Operates as a double buffer. All writes via the CPU access the shadow register. 1 Immediate mode. Only the active compare register is used. All writes and reads directly access the active register for immediate compare action
3-2	LOADBMODE	0-3h 0 1h 2h 3h	Active Counter-Compare B (CMPB) Load From Shadow Select Mode. This bit has no effect in immediate mode (CMPCTL[SHDWBMODE] = 1). 0 Load on CTR = 0: Time-base counter equal to zero (TBCNT = 0000h) 1h Load on CTR = PRD: Time-base counter equal to period (TBCNT = TBPRD) 2h Load on either CTR = 0 or CTR = PRD 3h Freeze (no loads possible)
1-0	LOADAMODE	0-3h 0 1h 2h 3h	Active Counter-Compare A (CMPA) Load From Shadow Select Mode. This bit has no effect in immediate mode (CMPCTL[SHDWAMODE] = 1). 0 Load on CTR = 0: Time-base counter equal to zero (TBCNT = 0000h) 1h Load on CTR = PRD: Time-base counter equal to period (TBCNT = TBPRD) 2h Load on either CTR = 0 or CTR = PRD 3h Freeze (no loads possible)

4.2.2 Counter-Compare A Register (CMPA)

The counter-compare A register (CMPA) is shown in [Figure 71](#) and described in [Table 59](#).

Figure 71. Counter-Compare A Register (CMPA)

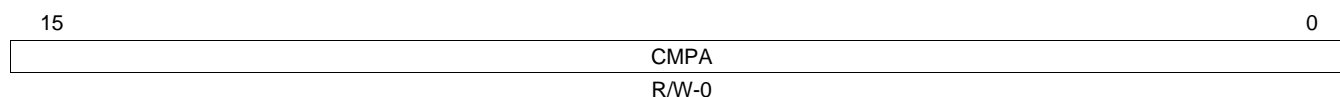

LEGEND: R/W = Read/Write; -n = value after reset

Table 59. Counter-Compare A Register (CMPA) Field Descriptions

Bits	Name	Value	Description
15-0	CMPA	0-FFFFh	<p>The value in the active CMPA register is continuously compared to the time-base counter (TBCNT). When the values are equal, the counter-compare module generates a "time-base counter equal to counter compare A" event. This event is sent to the action-qualifier where it is qualified and converted it into one or more actions. These actions can be applied to either the EPWMxA or the EPWMxB output depending on the configuration of the AQCTLA and AQCTLB registers. The actions that can be defined in the AQCTLA and AQCTLB registers include:</p> <ul style="list-style-type: none"> • Do nothing; the event is ignored. • Clear: Pull the EPWMxA and/or EPWMxB signal low • Set: Pull the EPWMxA and/or EPWMxB signal high • Toggle the EPWMxA and/or EPWMxB signal <p>Shadowing of this register is enabled and disabled by the CMPCTL[SHDWAMODE] bit. By default this register is shadowed.</p> <ul style="list-style-type: none"> • If CMPCTL[SHDWAMODE] = 0, then the shadow is enabled and any write or read will automatically go to the shadow register. In this case, the CMPCTL[LOADAMODE] bit field determines which event will load the active register from the shadow register. • Before a write, the CMPCTL[SHDWAFULL] bit can be read to determine if the shadow register is currently full. • If CMPCTL[SHDWAMODE] = 1, then the shadow register is disabled and any write or read will go directly to the active register, that is the register actively controlling the hardware. • In either mode, the active and shadow registers share the same memory map address.

4.2.3 Counter-Compare B Register (CMPB)

The counter-compare B register (CMPB) is shown in [Figure 72](#) and described in [Table 60](#).

Figure 72. Counter-Compare B Register (CMPB)

15	CMPB	0
R/W-0		

LEGEND: R/W = Read/Write; -n = value after reset

Table 60. Counter-Compare B Register (CMPB) Field Descriptions

Bits	Name	Value	Description
15-0	CMPB	0-FFFFh	<p>The value in the active CMPB register is continuously compared to the time-base counter (TBCNT). When the values are equal, the counter-compare module generates a "time-base counter equal to counter compare B" event. This event is sent to the action-qualifier where it is qualified and converted it into one or more actions. These actions can be applied to either the EPWMxA or the EPWMxB output depending on the configuration of the AQCTLA and AQCTLB registers. The actions that can be defined in the AQCTLA and AQCTLB registers include:</p> <ul style="list-style-type: none"> • Do nothing, event is ignored. • Clear: Pull the EPWMxA and/or EPWMxB signal low • Set: Pull the EPWMxA and/or EPWMxB signal high • Toggle the EPWMxA and/or EPWMxB signal <p>Shadowing of this register is enabled and disabled by the CMPCTL[SHDWBMODE] bit. By default this register is shadowed.</p> <ul style="list-style-type: none"> • If CMPCTL[SHDWBMODE] = 0, then the shadow is enabled and any write or read will automatically go to the shadow register. In this case, the CMPCTL[LOADBMODE] bit field determines which event will load the active register from the shadow register: • Before a write, the CMPCTL[SHDWBFULL] bit can be read to determine if the shadow register is currently full. • If CMPCTL[SHDWBMODE] = 1, then the shadow register is disabled and any write or read will go directly to the active register, that is the register actively controlling the hardware. • In either mode, the active and shadow registers share the same memory map address.

4.3 Action-Qualifier Submodule Registers

[Table 61](#) lists the memory-mapped registers for the action-qualifier submodule. See your device-specific data manual for the memory address of these registers. All other register offset addresses not listed in [Table 61](#) should be considered as reserved locations and the register contents should not be modified.

Table 61. Action-Qualifier Submodule Registers

Offset	Acronym	Register Description	Section
16h	AQCTLA	Action-Qualifier Output A Control Register	Section 4.3.1
18h	AQCTLB	Action-Qualifier Output B Control Register	Section 4.3.2
1Ah	AQSFRC	Action-Qualifier Software Force Register	Section 4.3.3
1Ch	AQCSFRC	Action-Qualifier Continuous Software Force Register	Section 4.3.4

4.3.1 Action-Qualifier Output A Control Register (AQCTLA)

The action-qualifier output A control register (AQCTLA) is shown in [Figure 73](#) and described in [Table 62](#).

Figure 73. Action-Qualifier Output A Control Register (AQCTLA)

15	12	11	10	9	8	7	6	5	4	3	2	1	0
Reserved		CBD		CBU		CAD		CAU		PRD		ZRO	
R-0		R/W-0		R/W-0		R/W-0		R/W-0		R/W-0		R/W-0	

LEGEND: R/W = Read/Write; R = Read only; -n = value after reset

Table 62. Action-Qualifier Output A Control Register (AQCTLA) Field Descriptions

Bits	Name	Value	Description
15-12	Reserved	0	Reserved
11-10	CBD	0-3h	Action when the time-base counter equals the active CMPB register and the counter is decrementing.
		0	Do nothing (action disabled)
		1h	Clear: force EPWMxA output low.
		2h	Set: force EPWMxA output high.
9-8	CBU	0-3h	Action when the counter equals the active CMPB register and the counter is incrementing.
		0	Do nothing (action disabled)
		1h	Clear: force EPWMxA output low.
		2h	Set: force EPWMxA output high.
7-6	CAD	0-3h	Action when the counter equals the active CMPA register and the counter is decrementing.
		0	Do nothing (action disabled)
		1h	Clear: force EPWMxA output low.
		2h	Set: force EPWMxA output high.
5-4	CAU	0-3h	Action when the counter equals the active CMPA register and the counter is incrementing.
		0	Do nothing (action disabled)
		1h	Clear: force EPWMxA output low.
		2h	Set: force EPWMxA output high.
3-2	PRD	0-3h	Action when the counter equals the period. Note: By definition, in count up-down mode when the counter equals period the direction is defined as 0 or counting down.
		0	Do nothing (action disabled)
		1h	Clear: force EPWMxA output low.
		2h	Set: force EPWMxA output high.
1-0	ZRO	0-3h	Action when counter equals zero. Note: By definition, in count up-down mode when the counter equals 0 the direction is defined as 1 or counting up.
		0	Do nothing (action disabled)
		1h	Clear: force EPWMxA output low.
		2h	Set: force EPWMxA output high.
3h	Toggle EPWMxA output: low output signal will be forced high, and a high signal will be forced low.		

4.3.2 Action-Qualifier Output B Control Register (AQCTLB)

The action-qualifier output B control register (AQCTLB) is shown in [Figure 74](#) and described in [Table 63](#).

Figure 74. Action-Qualifier Output B Control Register (AQCTLB)

15	12	11	10	9	8	7	6	5	4	3	2	1	0	
Reserved				CBD		CBU		CAD		CAU		PRD		ZRO
R-0				R/W-0		R/W-0		R/W-0		R/W-0		R/W-0		R/W-0

LEGEND: R/W = Read/Write; R = Read only; -n = value after reset

Table 63. Action-Qualifier Output B Control Register (AQCTLB) Field Descriptions

Bits	Name	Value	Description
15-12	Reserved	0	Reserved
11-10	CBD	0-3h	Action when the counter equals the active CMPB register and the counter is decrementing.
		0	Do nothing (action disabled)
		1h	Clear: force EPWMxB output low.
		2h	Set: force EPWMxB output high.
		3h	Toggle EPWMxB output: low output signal will be forced high, and a high signal will be forced low.
9-8	CBU	0-3h	Action when the counter equals the active CMPB register and the counter is incrementing.
		0	Do nothing (action disabled)
		1h	Clear: force EPWMxB output low.
		2h	Set: force EPWMxB output high.
		3h	Toggle EPWMxB output: low output signal will be forced high, and a high signal will be forced low.
7-6	CAD	0-3h	Action when the counter equals the active CMPA register and the counter is decrementing.
		0	Do nothing (action disabled)
		1h	Clear: force EPWMxB output low.
		2h	Set: force EPWMxB output high.
		3h	Toggle EPWMxB output: low output signal will be forced high, and a high signal will be forced low.
5-4	CAU	0-3h	Action when the counter equals the active CMPA register and the counter is incrementing.
		0	Do nothing (action disabled)
		1h	Clear: force EPWMxB output low.
		2h	Set: force EPWMxB output high.
		3h	Toggle EPWMxB output: low output signal will be forced high, and a high signal will be forced low.
3-2	PRD	0-3h	Action when the counter equals the period. Note: By definition, in count up-down mode when the counter equals period the direction is defined as 0 or counting down.
		0	Do nothing (action disabled)
		1h	Clear: force EPWMxB output low.
		2h	Set: force EPWMxB output high.
		3h	Toggle EPWMxB output: low output signal will be forced high, and a high signal will be forced low.
1-0	ZRO	0-3h	Action when counter equals zero. Note: By definition, in count up-down mode when the counter equals 0 the direction is defined as 1 or counting up.
		0	Do nothing (action disabled)
		1h	Clear: force EPWMxB output low.
		2h	Set: force EPWMxB output high.
		3h	Toggle EPWMxB output: low output signal will be forced high, and a high signal will be forced low.

4.3.3 Action-Qualifier Software Force Register (AQSFC)

The action-qualifier software force register (AQSFC) is shown in [Figure 75](#) and described in [Table 64](#).

Figure 75. Action-Qualifier Software Force Register (AQSFC)

15	8	7	6	5	4	3	2	1	0
Reserved		RLDCSF	OTSFB	ACTSFB	OTSFA	OTSFA		ACTSFA	
R-0		R/W-0	R/W-0	R/W-0	R/W-0	R/W-0		R/W-0	

LEGEND: R/W = Read/Write; R = Read only; -n = value after reset

Table 64. Action-Qualifier Software Force Register (AQSFC) Field Descriptions

Bit	Field	Value	Description
15-8	Reserved	0	Reserved
7-6	RLDCSF	0-3h	AQCSFRC Active Register Reload From Shadow Options
		0	Load on event counter equals zero
		1h	Load on event counter equals period
		2h	Load on event counter equals zero or counter equals period
		3h	Load immediately (the active register is directly accessed by the CPU and is not loaded from the shadow register).
5	OTSFB	0	One-Time Software Forced Event on Output B Writing a 0 (zero) has no effect. Always reads back a 0 This bit is auto cleared once a write to this register is complete, that is, a forced event is initiated.) This is a one-shot forced event. It can be overridden by another subsequent event on output B.
		1	Initiates a single s/w forced event
4-3	ACTSFB	0-3h	Action when One-Time Software Force B Is invoked
		0	Does nothing (action disabled)
		1h	Clear (low)
		2h	Set (high)
		3h	Toggle (Low -> High, High -> Low)
			Note: This action is not qualified by counter direction (CNT_dir)
2	OTSFA	0	One-Time Software Forced Event on Output A Writing a 0 (zero) has no effect. Always reads back a 0. This bit is auto cleared once a write to this register is complete (that is, a forced event is initiated).
		1	Initiates a single software forced event
1-0	ACTSFA	0-3h	Action When One-Time Software Force A Is Invoked
		0	Does nothing (action disabled)
		1h	Clear (low)
		2h	Set (high)
		3h	Toggle (Low → High, High → Low)
			Note: This action is not qualified by counter direction (CNT_dir)

4.3.4 Action-Qualifier Continuous Software Force Register (AQCSFRC)

The action-qualifier continuous software force register (AQCSFRC) is shown in [Figure 76](#) and described in [Table 65](#).

Figure 76. Action-Qualifier Continuous Software Force Register (AQCSFRC)

15	Reserved	4	3	2	1	0
	R-0		CSFB		CSFA	
			R/W-0		R/W-0	

LEGEND: R/W = Read/Write; R = Read only; -n = value after reset

Table 65. Action-Qualifier Continuous Software Force Register (AQCSFRC) Field Descriptions

Bits	Name	Value	Description
15-4	Reserved	0	Reserved
3-2	CSFB	0-3h	<p>Continuous Software Force on Output B</p> <p>In immediate mode, a continuous force takes effect on the next TBCLK edge.</p> <p>In shadow mode, a continuous force takes effect on the next TBCLK edge after a shadow load into the active register. To configure shadow mode, use AQSFRC[RLDCSF].</p> <p>0 Forcing disabled, that is, has no effect</p> <p>1h Forces a continuous low on output B</p> <p>2h Forces a continuous high on output B</p> <p>3h Software forcing is disabled and has no effect</p>
1-0	CSFA	0-3h	<p>Continuous Software Force on Output A</p> <p>In immediate mode, a continuous force takes effect on the next TBCLK edge.</p> <p>In shadow mode, a continuous force takes effect on the next TBCLK edge after a shadow load into the active register.</p> <p>0 Forcing disabled, that is, has no effect</p> <p>1h Forces a continuous low on output A</p> <p>2h Forces a continuous high on output A</p> <p>3h Software forcing is disabled and has no effect</p>

4.4 Dead-Band Generator Submodule Registers

[Table 66](#) lists the memory-mapped registers for the dead-band generator submodule. See your device-specific data manual for the memory address of these registers. All other register offset addresses not listed in [Table 66](#) should be considered as reserved locations and the register contents should not be modified.

Table 66. Dead-Band Generator Submodule Registers

Offset	Acronym	Register Description	Section
1Eh	DBCTL	Dead-Band Generator Control Register	Section 4.4.1
20h	DBRED	Dead-Band Generator Rising Edge Delay Register	Section 4.4.2
22h	DBFED	Dead-Band Generator Falling Edge Delay Register	Section 4.4.3

4.4.1 Dead-Band Generator Control Register (DBCTL)

The dead-band generator control register (DBCTL) is shown in [Figure 77](#) and described in [Table 67](#).

Figure 77. Dead-Band Generator Control Register (DBCTL)

15	6	5	4	3	2	1	0
Reserved		IN_MODE		POLSEL		OUT_MODE	
R-0		R/W-0		R/W-0		R/W-0	

LEGEND: R/W = Read/Write; R = Read only; -n = value after reset

Table 67. Dead-Band Generator Control Register (DBCTL) Field Descriptions

Bits	Name	Value	Description
15-6	Reserved	0	Reserved
5-4	IN_MODE	0-3h	<p>Dead Band Input Mode Control. Bit 5 controls the S5 switch and bit 4 controls the S4 switch shown in Figure 29. This allows you to select the input source to the falling-edge and rising-edge delay.</p> <p>To produce classical dead-band waveforms, the default is EPWMxA In is the source for both falling and rising-edge delays.</p> <p>0 EPWMxA In (from the action-qualifier) is the source for both falling-edge and rising-edge delay.</p> <p>1h EPWMxB In (from the action-qualifier) is the source for rising-edge delayed signal.</p> <p>EPWMxA In (from the action-qualifier) is the source for falling-edge delayed signal.</p> <p>2h EPWMxA In (from the action-qualifier) is the source for rising-edge delayed signal.</p> <p>EPWMxB In (from the action-qualifier) is the source for falling-edge delayed signal.</p> <p>3h EPWMxB In (from the action-qualifier) is the source for both rising-edge delay and falling-edge delayed signal.</p>
3-2	POLSEL	0-3h	<p>Polarity Select Control. Bit 3 controls the S3 switch and bit 2 controls the S2 switch shown in Figure 29. This allows you to selectively invert one of the delayed signals before it is sent out of the dead-band submodule.</p> <p>The following descriptions correspond to classical upper/lower switch control as found in one leg of a digital motor control inverter.</p> <p>These assume that DBCTL[OUT_MODE] = 1,1 and DBCTL[IN_MODE] = 0,0. Other enhanced modes are also possible, but not regarded as typical usage modes.</p> <p>0 Active high (AH) mode. Neither EPWMxA nor EPWMxB is inverted (default).</p> <p>1h Active low complementary (ALC) mode. EPWMxA is inverted.</p> <p>2h Active high complementary (AHC). EPWMxB is inverted.</p> <p>3h Active low (AL) mode. Both EPWMxA and EPWMxB are inverted.</p>
1-0	OUT_MODE	0-3h	<p>Dead-band Output Mode Control. Bit 1 controls the S1 switch and bit 0 controls the S0 switch shown in Figure 29. This allows you to selectively enable or bypass the dead-band generation for the falling-edge and rising-edge delay.</p> <p>0 Dead-band generation is bypassed for both output signals. In this mode, both the EPWMxA and EPWMxB output signals from the action-qualifier are passed directly to the PWM-chopper submodule.</p> <p>In this mode, the POLSEL and IN_MODE bits have no effect.</p> <p>1h Disable rising-edge delay. The EPWMxA signal from the action-qualifier is passed straight through to the EPWMxA input of the PWM-chopper submodule.</p> <p>The falling-edge delayed signal is seen on output EPWMxB. The input signal for the delay is determined by DBCTL[IN_MODE].</p> <p>2h Disable falling-edge delay. The EPWMxB signal from the action-qualifier is passed straight through to the EPWMxB input of the PWM-chopper submodule.</p> <p>The rising-edge delayed signal is seen on output EPWMxA. The input signal for the delay is determined by DBCTL[IN_MODE].</p> <p>3h Dead-band is fully enabled for both rising-edge delay on output EPWMxA and falling-edge delay on output EPWMxB. The input signal for the delay is determined by DBCTL[IN_MODE].</p>

4.4.2 Dead-Band Generator Rising Edge Delay Register (DBRED)

The dead-band generator rising edge delay register (DBRED) is shown in [Figure 78](#) and described in [Table 68](#).

Figure 78. Dead-Band Generator Rising Edge Delay Register (DBRED)



LEGEND: R/W = Read/Write; R = Read only; -n = value after reset

Table 68. Dead-Band Generator Rising Edge Delay Register (DBRED) Field Descriptions

Bits	Name	Value	Description
15-10	Reserved	0	Reserved
9-0	DEL	0-3FFh	Rising Edge Delay Count. 10-bit counter.

4.4.3 Dead-Band Generator Falling Edge Delay Register (DBFED)

The dead-band generator falling edge delay register (DBFED) is shown in [Figure 79](#) and described in [Table 69](#).

Figure 79. Dead-Band Generator Falling Edge Delay Register (DBFED)

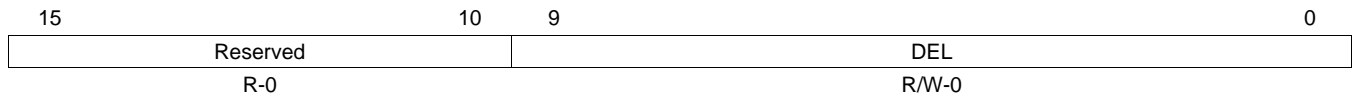

LEGEND: R/W = Read/Write; R = Read only; -n = value after reset

Table 69. Dead-Band Generator Falling Edge Delay Register (DBFED) Field Descriptions

Bits	Name	Value	Description
15-10	Reserved	0	Reserved
9-0	DEL	0-3FFh	Falling Edge Delay Count. 10-bit counter

4.5 PWM-Chopper Submodule Register

The PWM-chopper control register (PCCTL) is shown in [Figure 80](#) and described in [Table 70](#).

Figure 80. PWM-Chopper Control Register (PCCTL)

15	11	10	8	7	5	4	1	0
Reserved		CHPDUTY		CHPFREQ		OSHTWTH		CHPEN
R-0		R/W-0		R/W-0		R/W-0		R/W-0

LEGEND: R/W = Read/Write; R = Read only; -n = value after reset

Table 70. PWM-Chopper Control Register (PCCTL) Bit Descriptions

Bits	Name	Value	Description
15-11	Reserved	0	Reserved
10-8	CHPDUTY	0-7h	Chopping Clock Duty Cycle
		0	Duty = 1/8 (12.5%)
		1h	Duty = 2/8 (25.0%)
		2h	Duty = 3/8 (37.5%)
		3h	Duty = 4/8 (50.0%)
		4h	Duty = 5/8 (62.5%)
		5h	Duty = 6/8 (75.0%)
		6h	Duty = 7/8 (87.5%)
		7h	Reserved
7-5	CHPFREQ	0-7h	Chopping Clock Frequency
		0	Divide by 1 (no prescale)
		1h	Divide by 2
		2h	Divide by 3
		3h-7h	Divide by 4 to divide by 8
4-1	OSHTWTH	0-Fh	One-Shot Pulse Width
		0	1 × SYSCLKOUT/8 wide
		1h	2 × SYSCLKOUT/8 wide
		2h	3 × SYSCLKOUT/8 wide
		3h-Fh	4 × SYSCLKOUT/8 wide to 16 × SYSCLKOUT/8 wide
0	CHPEN		PWM-chopping Enable
		0	Disable (bypass) PWM chopping function
		1	Enable chopping function

4.6 Trip-Zone Submodule Registers

Table 71 lists the memory-mapped registers for the trip-zone submodule. See your device-specific data manual for the memory address of these registers. All other register offset addresses not listed in Table 71 should be considered as reserved locations and the register contents should not be modified. All trip-zone registers are EALLOW protected and can be modified only after executing the EALLOW instruction. For more information, see your device-specific data manual.

Table 71. Trip-Zone Submodule Registers

Offset	Acronym	Register Description	Section
24h	TZSEL	Trip-Zone Select Register	Section 4.6.1
28h	TZCTL	Trip-Zone Control Register	Section 4.6.2
2Ah	TZEINT	Trip-Zone Enable Interrupt Register	Section 4.6.3
2Ch	TZFLG	Trip-Zone Flag Register	Section 4.6.4
2Eh	TZCLR	Trip-Zone Clear Register	Section 4.6.5
30h	TZFRC	Trip-Zone Force Register	Section 4.6.6

4.6.1 Trip-Zone Select Register (TZSEL)

The trip-zone select register (TZSEL) is shown in Figure 81 and described in Table 72.

Figure 81. Trip-Zone Select Register (TZSEL)

15	9	8	7	1	0
Reserved/OSHT n ⁽¹⁾		OSHT1	Reserved/CBC n ⁽¹⁾		CBC1
R/W-0		R/W-0	R/W-0		R/W-0

LEGEND: R/W = Read/Write; - n = value after reset

⁽¹⁾ Number of register bits depends on how many trip-zone pins are available in the device. See your device-specific data manual.

Table 72. Trip-Zone Submodule Select Register (TZSEL) Field Descriptions

Bits	Name	Value	Description
15-8	OSHT n	0 1	Trip-zone n (\overline{TZn}) select. One-Shot (OSHT) trip-zone enable/disable. When any of the enabled pins go low, a one-shot trip event occurs for this ePWM module. When the event occurs, the action defined in the TZCTL register (Section 4.6.2) is taken on the EPWMxA and EPWMxB outputs. The one-shot trip condition remains latched until you clear the condition via the TZCLR register (Section 4.6.5). 0 Disable \overline{TZn} as a one-shot trip source for this ePWM module. 1 Enable \overline{TZn} as a one-shot trip source for this ePWM module.
7-0	CBC n	0 1	Trip-zone n (\overline{TZn}) select. Cycle-by-Cycle (CBC) trip-zone enable/disable. When any of the enabled pins go low, a cycle-by-cycle trip event occurs for this ePWM module. When the event occurs, the action defined in the TZCTL register (Section 4.6.2) is taken on the EPWMxA and EPWMxB outputs. A cycle-by-cycle trip condition is automatically cleared when the time-base counter reaches zero. 0 Disable \overline{TZn} as a CBC trip source for this ePWM module. 1 Enable \overline{TZn} as a CBC trip source for this ePWM module.

4.6.2 Trip-Zone Control Register (TZCTL)

The trip-zone control register (TZCTL) is shown in [Figure 82](#) and described in [Table 73](#).

Figure 82. Trip-Zone Control Register (TZCTL)

15	Reserved	4	3	2	1	0
R-0			TZB		TZA	
R-0			R/W-0		R/W-0	

LEGEND: R/W = Read/Write; R = Read only; -n = value after reset

Table 73. Trip-Zone Control Register (TZCTL) Field Descriptions

Bits	Name	Value	Description
15–4	Reserved	0	Reserved
3–2	TZB	0-3h	When a trip event occurs the following action is taken on output EPWMxB. Which trip-zone pins can cause an event is defined in the TZSEL register (Section 4.6.1).
		0	High impedance (EPWMxB = High-impedance state)
		1h	Force EPWMxB to a high state
		2h	Force EPWMxB to a low state
		3h	Do nothing, no action is taken on EPWMxB.
1–0	TZA	0-3h	When a trip event occurs the following action is taken on output EPWMxA. Which trip-zone pins can cause an event is defined in the TZSEL register (Section 4.6.1).
		0	High impedance (EPWMxA = High-impedance state)
		1h	Force EPWMxA to a high state
		2h	Force EPWMxA to a low state
		3h	Do nothing, no action is taken on EPWMxA.

4.6.3 Trip-Zone Enable Interrupt Register (TZEINT)

The trip-zone enable interrupt register (TZEINT) is shown in [Figure 83](#) and described in [Table 74](#).

Figure 83. Trip-Zone Enable Interrupt Register (TZEINT)

15	Reserved	3	2	1	0
R-0			OST	CBC	Rsvd
R-0			R/W-0	R/W-0	R-0

LEGEND: R/W = Read/Write; R = Read only; -n = value after reset

Table 74. Trip-Zone Enable Interrupt Register (TZEINT) Field Descriptions

Bits	Name	Value	Description
15-3	Reserved	0	Reserved
2	OST	0-1	Trip-zone One-Shot Interrupt Enable
		0	Disable one-shot interrupt generation
		1	Enable Interrupt generation; a one-shot trip event will cause a EPWMxTZINT interrupt.
1	CBC	0-1	Trip-zone Cycle-by-Cycle Interrupt Enable
		0	Disable cycle-by-cycle interrupt generation.
		1	Enable interrupt generation; a cycle-by-cycle trip event will cause an EPWMxTZINT interrupt.
0	Reserved	0	Reserved

4.6.4 Trip-Zone Flag Register (TZFLG)

The trip-zone flag register (TZFLG) is shown in [Figure 84](#) and described in [Table 75](#).

Figure 84. Trip-Zone Flag Register (TZFLG)

15	3	2	1	0
Reserved		OST	CBC	INT
R-0		R-0	R-0	R-0

LEGEND: R/W = Read/Write; R = Read only; -n = value after reset

Table 75. Trip-Zone Flag Register (TZFLG) Field Descriptions

Bits	Name	Value	Description
15-3	Reserved	0	Reserved
2	OST	0 1	Latched Status Flag for A One-Shot Trip Event. 0 No one-shot trip event has occurred. 1 Indicates a trip event has occurred on a pin selected as a one-shot trip source. This bit is cleared by writing the appropriate value to the TZCLR register (Section 4.6.5).
1	CBC	0 1	Latched Status Flag for Cycle-By-Cycle Trip Event 0 No cycle-by-cycle trip event has occurred. 1 Indicates a trip event has occurred on a pin selected as a cycle-by-cycle trip source. The TZFLG[CBC] bit will remain set until it is manually cleared by the user. If the cycle-by-cycle trip event is still present when the CBC bit is cleared, then CBC will be immediately set again. The specified condition on the pins is automatically cleared when the ePWM time-base counter reaches zero (TBCNT = 0000h) if the trip condition is no longer present. The condition on the pins is only cleared when the TBCNT = 0000h no matter where in the cycle the CBC flag is cleared. This bit is cleared by writing the appropriate value to the TZCLR register (Section 4.6.5).
0	INT	0 1	Latched Trip Interrupt Status Flag 0 Indicates no interrupt has been generated. 1 Indicates an EPWMxTZINT interrupt was generated because of a trip condition. No further EPWMxTZINT interrupts will be generated until this flag is cleared. If the interrupt flag is cleared when either CBC or OST is set, then another interrupt pulse will be generated. Clearing all flag bits will prevent further interrupts. This bit is cleared by writing the appropriate value to the TZCLR register (Section 4.6.5).

4.6.5 Trip-Zone Clear Register (TZCLR)

The trip-zone clear register (TZCLR) is shown in [Figure 85](#) and described in [Table 76](#).

Figure 85. Trip-Zone Clear Register (TZCLR)

15	Reserved	3	2	1	0
			OST	CBC	INT
R-0			R/W-0	R/W-0	R/W-0

LEGEND: R/W = Read/Write; R = Read only; -n = value after reset

Table 76. Trip-Zone Clear Register (TZCLR) Field Descriptions

Bits	Name	Value	Description
15-3	Reserved	0	Reserved
2	OST	0	Clear Flag for One-Shot Trip (OST) Latch Has no effect. Always reads back a 0.
		1	Clears this Trip (set) condition.
1	CBC	0	Clear Flag for Cycle-By-Cycle (CBC) Trip Latch Has no effect. Always reads back a 0.
		1	Clears this Trip (set) condition.
0	INT	0	Global Interrupt Clear Flag Has no effect. Always reads back a 0.
		1	Clears the trip-interrupt flag for this ePWM module (TZFLG[INT]). NOTE: No further EPWMxTZINT interrupts will be generated until the flag is cleared. If the TZFLG[INT] bit is cleared and any of the other flag bits are set, then another interrupt pulse will be generated. Clearing all flag bits will prevent further interrupts.

4.6.6 Trip-Zone Force Register (TZFRC)

The trip-zone force register (TZFRC) is shown in [Figure 86](#) and described in [Table 77](#).

Figure 86. Trip-Zone Force Register (TZFRC)

15	Reserved	3	2	1	0
			OST	CBC	Rsvd
R-0			R/W-0	R/W-0	R-0

LEGEND: R/W = Read/Write; R = Read only; -n = value after reset

Table 77. Trip-Zone Force Register (TZFRC) Field Descriptions

Bits	Name	Value	Description
15-3	Reserved	0	Reserved
2	OST	0	Force a One-Shot Trip Event via Software Writing of 0 is ignored. Always reads back a 0.
		1	Forces a one-shot trip event and sets the TZFLG[OST] bit.
1	CBC	0	Force a Cycle-by-Cycle Trip Event via Software Writing of 0 is ignored. Always reads back a 0.
		1	Forces a cycle-by-cycle trip event and sets the TZFLG[CBC] bit.
0	Reserved	0	Reserved

4.7 Event-Trigger Submodule Registers

Table 78 lists the memory-mapped registers for the event-trigger submodule. See your device-specific data manual for the memory address of these registers. All other register offset addresses not listed in Table 78 should be considered as reserved locations and the register contents should not be modified.

Table 78. Event-Trigger Submodule Registers

Offset	Acronym	Register Description	Section
32h	ETSEL	Event-Trigger Selection Register	Section 4.7.1
34h	ETPS	Event-Trigger Prescale Register	Section 4.7.2
36h	ETFLG	Event-Trigger Flag Register	Section 4.7.3
38h	ETCLR	Event-Trigger Clear Register	Section 4.7.4
3Ah	ETFRC	Event-Trigger Force Register	Section 4.7.5

4.7.1 Event-Trigger Selection Register (ETSEL)

The event-trigger selection register (ETSEL) is shown in Figure 87 and described in Table 79.

Figure 87. Event-Trigger Selection Register (ETSEL)

15	4	3	2	0
Reserved		INTEN	INTSEL	
R-0		R/W-0	R/W-0	

LEGEND: R/W = Read/Write; R = Read only; -n = value after reset

Table 79. Event-Trigger Selection Register (ETSEL) Field Descriptions

Bits	Name	Value	Description
15-4	Reserved	0	Reserved
3	INTEN	0 1	Enable ePWM Interrupt (EPWMx_INT) Generation Disable EPWMx_INT generation Enable EPWMx_INT generation
2-0	INTSEL	0-7h 0 1h 2h 3h 4h 5h 6h 7h	ePWM Interrupt (EPWMx_INT) Selection Options Reserved Enable event time-base counter equal to zero. (TBCNT = 0000h) Enable event time-base counter equal to period (TBCNT = TBPRD) Reserved Enable event time-base counter equal to CMPA when the timer is incrementing. Enable event time-base counter equal to CMPA when the timer is decrementing. Enable event: time-base counter equal to CMPB when the timer is incrementing. Enable event: time-base counter equal to CMPB when the timer is decrementing.

4.7.2 Event-Trigger Prescale Register (ETPS)

The event-trigger prescale register (ETPS) is shown in [Figure 88](#) and described in [Table 80](#).

Figure 88. Event-Trigger Prescale Register (ETPS)

15	4	3	2	1	0
Reserved			INTCNT	INTPRD	
R-0			R-0	R/W-0	

LEGEND: R/W = Read/Write; R = Read only; -n = value after reset

Table 80. Event-Trigger Prescale Register (ETPS) Field Descriptions

Bits	Name	Value	Description
15-4	Reserved	0	Reserved
3-2	INTCNT	0-3h	ePWM Interrupt Event (EPWMx_INT) Counter Register. These bits indicate how many selected ETSEL[INTSEL] events have occurred. These bits are automatically cleared when an interrupt pulse is generated. If interrupts are disabled, ETSEL[INT] = 0 or the interrupt flag is set, ETFLG[INT] = 1, the counter will stop counting events when it reaches the period value ETPS[INTCNT] = ETPS[INTPRD].
		0	No events have occurred.
		1h	1 event has occurred.
		2h	2 events have occurred.
		3h	3 events have occurred.
1-0	INTPRD	0-3h	ePWM Interrupt (EPWMx_INT) Period Select. These bits determine how many selected ETSEL[INTSEL] events need to occur before an interrupt is generated. To be generated, the interrupt must be enabled (ETSEL[INT] = 1). If the interrupt status flag is set from a previous interrupt (ETFLG[INT] = 1) then no interrupt will be generated until the flag is cleared via the ETCLR[INT] bit. This allows for one interrupt to be pending while another is still being serviced. Once the interrupt is generated, the ETPS[INTCNT] bits will automatically be cleared. Writing a INTPRD value that is the same as the current counter value will trigger an interrupt if it is enabled and the status flag is clear. Writing a INTPRD value that is less than the current counter value will result in an undefined state. If a counter event occurs at the same instant as a new zero or non-zero INTPRD value is written, the counter is incremented.
		0	Disable the interrupt event counter. No interrupt will be generated and ETFRC[INT] is ignored.
		1h	Generate an interrupt on the first event INTCNT = 01 (first event)
		2h	Generate interrupt on ETPS[INTCNT] = 1,0 (second event)
		3h	Generate interrupt on ETPS[INTCNT] = 1,1 (third event)

4.7.3 Event-Trigger Flag Register (ETFLG)

The event-trigger flag register (ETFLG) is shown in [Figure 89](#) and described in [Table 81](#).

Figure 89. Event-Trigger Flag Register (ETFLG)

15	Reserved	1	0
R-0		INT	R-0

LEGEND: R = Read only; -n = value after reset

Table 81. Event-Trigger Flag Register (ETFLG) Field Descriptions

Bits	Name	Value	Description
15-1	Reserved	0	Reserved
0	INT	0	Latched ePWM Interrupt (EPWMx_INT) Status Flag Indicates no event occurred
		1	Indicates that an ePWMx interrupt (EPWMx_INT) was generated. No further interrupts will be generated until the flag bit is cleared. Up to one interrupt can be pending while the ETFLG[INT] bit is still set. If an interrupt is pending, it will not be generated until after the ETFLG[INT] bit is cleared. Refer to Figure 42 .

4.7.4 Event-Trigger Clear Register (ETCLR)

The event-trigger clear register (ETCLR) is shown in [Figure 90](#) and described in [Table 82](#).

Figure 90. Event-Trigger Clear Register (ETCLR)

15	Reserved	1	0
R-0		INT	R-0

LEGEND: R = Read only; -n = value after reset

Table 82. Event-Trigger Clear Register (ETCLR) Field Descriptions

Bits	Name	Value	Description
15-1	Reserved	0	Reserved
0	INT	0	ePWM Interrupt (EPWMx_INT) Flag Clear Bit Writing a 0 has no effect. Always reads back a 0.
		1	Clears the ETFLG[INT] flag bit and enable further interrupts pulses to be generated.

4.7.5 Event-Trigger Force Register (ETFRC)

The event-trigger force register (ETFRC) is shown in [Figure 91](#) and described in [Table 83](#).

Figure 91. Event-Trigger Force Register (ETFRC)

15	Reserved	1	0
R-0		INT R-0	

LEGEND: R = Read only; -n = value after reset

Table 83. Event-Trigger Force Register (ETFRC) Field Descriptions

Bits	Name	Value	Description
15-1	Reserved	0	Reserved
0	INT	0	INT Force Bit. The interrupt will only be generated if the event is enabled in the ETSEL register. The INT flag bit will be set regardless. Writing 0 to this bit will be ignored. Always reads back a 0.
		1	Generates an interrupt on EPWMxINT and set the INT flag bit. This bit is used for test purposes.

4.8 High-Resolution PWM Submodule Registers

[Table 84](#) lists the memory-mapped registers for the high-resolution PWM submodule. See your device-specific data manual for the memory address of these registers. All other register offset addresses not listed in [Table 84](#) should be considered as reserved locations and the register contents should not be modified.

Table 84. High-Resolution PWM Submodule Registers

Offset	Acronym	Register Description	Section
4h	TBPHSHR	Time-Base Phase High-Resolution Register	Section 4.8.1
10h	CMPAHR	Counter-Compare A High-Resolution Register	Section 4.8.2
1020h	HRCNFG	HRPWM Configuration Register ⁽¹⁾	Section 4.8.3

⁽¹⁾ This register is EALLOW protected.

4.8.1 Time-Base Phase High-Resolution Register (TBPHSHR)

The time-base phase high-resolution register (TBPHSHR) is shown in [Figure 92](#) and described in [Table 85](#).

Figure 92. Time-Base Phase High-Resolution Register (TBPHSHR)

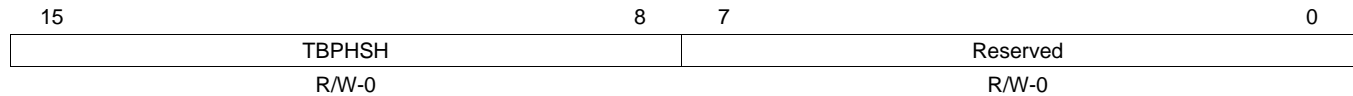

LEGEND: R/W = Read/Write; R = Read only; -n = value after reset

Table 85. Time-Base Phase High-Resolution Register (TBPHSHR) Field Descriptions

Bit	Field	Value	Description
15-8	TBPHSH	0-FFh	Time-base phase high-resolution bits
7-0	Reserved	0	Reserved

4.8.2 Counter-Compare A High-Resolution Register (CMPAHR)

The counter-compare A high-resolution register (CMPAHR) is shown in [Figure 93](#) and described in [Table 86](#).

Figure 93. Counter-Compare A High-Resolution Register (CMPAHR)

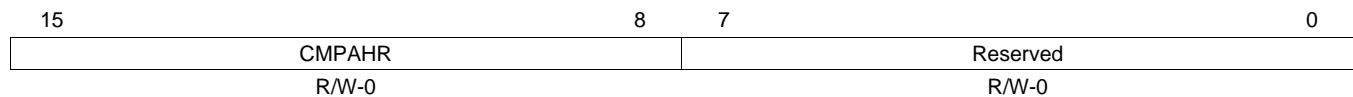

LEGEND: R/W = Read/Write; R = Read only; -n = value after reset

Table 86. Counter-Compare A High-Resolution Register (CMPAHR) Field Descriptions

Bit	Field	Value	Description
15-8	CMPAHR	1-FFh	Compare A High-Resolution register bits for MEP step control. A minimum value of 1h is needed to enable HRPWM capabilities. Valid MEP range of operation 1-255h.
7-0	Reserved	0	Reserved

4.8.3 HRPWM Configuration Register (HRCNFG)

The HRPWM configuration register (HRCNFG) is shown in [Figure 94](#) and described in [Table 87](#). This register is EALLOW protected.

Figure 94. HRPWM Configuration Register (HRCNFG)

15	4	3	2	1	0
Reserved		HRLOAD	CTLMODE	EDGMODE	
R-0		R/W-0	R/W-0	R/W-0	

LEGEND: R/W = Read/Write; R = Read only; -n = value after reset

Table 87. HRPWM Configuration Register (HRCNFG) Field Descriptions

Bit	Field	Value	Description
15-4	Reserved	0	Reserved
3	HRLOAD	0 1	Shadow mode bit: Selects the time event that loads the CMPAHR shadow value into the active register: CTR = 0 (counter equals zero) CTR = PRD (counter equal period) Note: Load mode selection is valid only if CTLMODE = 0 has been selected. You should select this event to match the selection of the CMPA load mode (CMPCTL[LOADMODE] bits) in the EPWM module as follows: 0 Load on CTR = 0: Time-base counter equal to zero (TBCNT = 0000h) 1h Load on CTR = PRD: Time-base counter equal to period (TBCNT = TBPRD) 2h Load on either CTR = 0 or CTR = PRD (should not be used with HRPWM) 3h Freeze (no loads possible – should not be used with HRPWM)
2	CTLMODE	0 1	Control Mode Bits: Selects the register (CMP or TBPHS) that controls the MEP: 0 CMPAHR(8) Register controls the edge position (this is duty control mode). (default on reset) 1 TBPHSHR(8) Register controls the edge position (this is phase control mode).
1-0	EDGMODE	0-3h 0 1h 2h 3h	Edge Mode Bits: Selects the edge of the PWM that is controlled by the micro-edge position (MEP) logic: 0 HRPWM capability is disabled (default on reset) 1h MEP control of rising edge 2h MEP control of falling edge 3h MEP control of both edges

Appendix A Revision History

[Table 88](#) lists the changes made since the previous version of this document.

Table 88. Document Revision History

Reference	Additions/Modifications/Deletions
Section 2.10.1	Deleted last bullet.
Section 2.10.5.2	Deleted Note.
Section 2.10.5.3	Changed first paragraph.
Section 2.10.5.3	Deleted subsection 2.10.6 Scale Factor Optimizing Software (SFO). Subsequent examples, figures, and tables renumbered.

IMPORTANT NOTICE

Texas Instruments Incorporated and its subsidiaries (TI) reserve the right to make corrections, modifications, enhancements, improvements, and other changes to its products and services at any time and to discontinue any product or service without notice. Customers should obtain the latest relevant information before placing orders and should verify that such information is current and complete. All products are sold subject to TI's terms and conditions of sale supplied at the time of order acknowledgment.

TI warrants performance of its hardware products to the specifications applicable at the time of sale in accordance with TI's standard warranty. Testing and other quality control techniques are used to the extent TI deems necessary to support this warranty. Except where mandated by government requirements, testing of all parameters of each product is not necessarily performed.

TI assumes no liability for applications assistance or customer product design. Customers are responsible for their products and applications using TI components. To minimize the risks associated with customer products and applications, customers should provide adequate design and operating safeguards.

TI does not warrant or represent that any license, either express or implied, is granted under any TI patent right, copyright, mask work right, or other TI intellectual property right relating to any combination, machine, or process in which TI products or services are used. Information published by TI regarding third-party products or services does not constitute a license from TI to use such products or services or a warranty or endorsement thereof. Use of such information may require a license from a third party under the patents or other intellectual property of the third party, or a license from TI under the patents or other intellectual property of TI.

Reproduction of TI information in TI data books or data sheets is permissible only if reproduction is without alteration and is accompanied by all associated warranties, conditions, limitations, and notices. Reproduction of this information with alteration is an unfair and deceptive business practice. TI is not responsible or liable for such altered documentation. Information of third parties may be subject to additional restrictions.

Resale of TI products or services with statements different from or beyond the parameters stated by TI for that product or service voids all express and any implied warranties for the associated TI product or service and is an unfair and deceptive business practice. TI is not responsible or liable for any such statements.

TI products are not authorized for use in safety-critical applications (such as life support) where a failure of the TI product would reasonably be expected to cause severe personal injury or death, unless officers of the parties have executed an agreement specifically governing such use. Buyers represent that they have all necessary expertise in the safety and regulatory ramifications of their applications, and acknowledge and agree that they are solely responsible for all legal, regulatory and safety-related requirements concerning their products and any use of TI products in such safety-critical applications, notwithstanding any applications-related information or support that may be provided by TI. Further, Buyers must fully indemnify TI and its representatives against any damages arising out of the use of TI products in such safety-critical applications.

TI products are neither designed nor intended for use in military/aerospace applications or environments unless the TI products are specifically designated by TI as military-grade or "enhanced plastic." Only products designated by TI as military-grade meet military specifications. Buyers acknowledge and agree that any such use of TI products which TI has not designated as military-grade is solely at the Buyer's risk, and that they are solely responsible for compliance with all legal and regulatory requirements in connection with such use.

TI products are neither designed nor intended for use in automotive applications or environments unless the specific TI products are designated by TI as compliant with ISO/TS 16949 requirements. Buyers acknowledge and agree that, if they use any non-designated products in automotive applications, TI will not be responsible for any failure to meet such requirements.

Following are URLs where you can obtain information on other Texas Instruments products and application solutions:

Products

Amplifiers	amplifier.ti.com
Data Converters	dataconverter.ti.com
DLP® Products	www.dlp.com
DSP	dsp.ti.com
Clocks and Timers	www.ti.com/clocks
Interface	interface.ti.com
Logic	logic.ti.com
Power Mgmt	power.ti.com
Microcontrollers	microcontroller.ti.com
RFID	www.ti-rfid.com
RF/IF and ZigBee® Solutions	www.ti.com/lprf

Applications

Audio	www.ti.com/audio
Automotive	www.ti.com/automotive
Broadband	www.ti.com/broadband
Digital Control	www.ti.com/digitalcontrol
Medical	www.ti.com/medical
Military	www.ti.com/military
Optical Networking	www.ti.com/opticalnetwork
Security	www.ti.com/security
Telephony	www.ti.com/telephony
Video & Imaging	www.ti.com/video
Wireless	www.ti.com/wireless

Mailing Address: Texas Instruments, Post Office Box 655303, Dallas, Texas 75265
Copyright © 2009, Texas Instruments Incorporated