



TG105/145 Hardware Design



Wireless Your Life

Contents

Contents	2
1. Version History	7
2. Introduction	8
2.1. Related documents.....	8
2.2. Terms and abbreviations.....	9
2.3. Safety caution	11
3. Product concept	13
3.1. Key features.....	13
3.2. Functional diagram.....	15
3.3. Evaluation board.....	16
4. Application interface	17
4.1. Pin description	17
4.2. Operating modes.....	21
4.3. Power supply	22
4.3.1 Power supply pins.....	23
4.3.2 Minimizing power losses	23
4.3.3 Monitoring power supply.....	24
4.4. Power up and power down scenarios.....	24
4.4.1 Turn on	24
4.4.2 Turn off.....	27
4.4.3 Restart module using the PWRKEY pin.....	28
4.5. Power saving	29
4.5.1 Minimum functionality mode	29
4.5.2 Sleep mode (slow clock mode).....	30
4.5.3 Wake up module from SLEEP mode.....	30
4.6. Summary of state transitions (except SLEEP mode).....	30
4.7. RTC backup.....	31
4.8. Serial interfaces	32
4.8.1 Function of serial port & debug port supporting	34
4.8.2 Software upgrade and software debug.....	35
4.9. Audio interfaces.....	37
4.9.1 Speaker interface configuration.....	39
4.9.2 Microphone interfaces configuration	41
4.9.3 Earphone interface configuration	41
4.10. Buzzer.....	42
4.11. SIM card interface	43
4.11.1 SIM card application.....	43
4.11.2 Design considerations for SIM card holder	45
4.12. LCD interface	47
4.13. Keypad interface.....	48
4.14. ADC.....	49

4.15. Behaviors of the RI.....	50
4.16. Network status indication	51
4.17. General purpose input & output (GPIO).....	52
4.18. Open drain output (LIGHT_MOS).....	52
5. Antenna interface.....	54
5.1. Antenna installation.....	54
5.2. RF output power	55
5.3. RF receive sensitivity	55
5.4. Operating frequencies.....	55
6. Electrical, reliability and radio characteristics.....	56
6.1. Absolute maximum ratings.....	56
6.2. Operating temperatures.....	56
6.3. Power supply ratings	56
6.4. Current consumption	58
6.5. Electro-static discharge.....	60
7. Product information	61
8. Mechanics	62
8.1. Mechanical dimensions of module and module PCB decal.....	62
8.2. Top view of the module.....	65
8.3. PIN assignment of SMT pads of the module.....	65
9. Contact us	67

Table Index

Table 1: Related documents	8
Table 2: Terms and abbreviations.....	9
Table 3: Module key features	13
Table 4: Coding schemes and maximum net data rates over air interface.....	15
Table 5: Pin description.....	17
Table 6: Overview of operating modes	21
Table 7: AT commands used in alarm mode.....	26
Table 8: Summary of state transitions	30
Table 9: Logic levels of the serial port and debug port	33
Table 10: Pin definition of the serial interfaces.....	33
Table 11: Pin definition of Audio interface	38
Table 12: MIC input characteristics	42
Table 13: SPK Output Characteristics.....	42
Table 14: Pin definition of the Buzzer.....	43
Table 15: Buzzer Output Characteristics.....	43
Table 16: Pin definition of the SIM interface.....	44
Table 17: Pin description (Amphenol SIM card holder)	46

Figure Index

Figure 1: Module functional diagram.....	16
Figure 2: Reference circuit of the VBAT input	22
Figure 3: Reference circuit of the source power supply input.....	23
Figure 4: Power supply limits during transmitting burst.....	23
Figure 5: Turn on the module using driving circuit	25
Figure6: Turn on the module using button	25
Figure 7: Timing of turn on system.....	25
Figure 8: Timing of turn off system	27
Figure 9 : Timing of restart system	29
Figure 10: RTC supply from non-chargeable battery	31
Figure 11: RTC supply from rechargeable battery	31
Figure 12: RTC supply from capacitor	32
Figure 13: Seiko XH414H-IV01E Charge Characteristic	32
Figure 14: Connection of serial interfaces	34
Figure 15: Connection of software upgrade	36
Figure 16: Connection of software debug	36
Figure 17: RS232 level converter circuit	37
Figure 18: Speaker interface configuration of AOUT1	39
Figure 19: Speaker interface with amplifier configuration of AOUT1	39
Figure 20: Speaker interface configuration of AOUT2.....	40
Figure 21: Speaker interface with amplifier configuration of AOUT2	40
Figure 22: Microphone interface configuration	41
Figure 23: Reference circuit for Buzzer.....	43
Figure 24: Reference circuit of the 8 pins SIM card	45
Figure 25: Reference circuit of the 6 pins SIM card	45
Figure 26: Amphenol C707 10M006 512 2 SIM card holder	46
Figure 27: Molex 91228 SIM card holder.....	47
Figure 28: Reference circuit of the keypad interface	49
Figure 29: Internal circuit of the ADC	50
Figure 30: Module Services as Receiver.....	51
Figure 31 : Module Services as caller	51
Figure 32: Reference circuit of the NETLIGHT	52
Figure 33: Reference circuit of the LIGHT_MOS	53
Figure 34: The RF interface of module	54
Figure 35: TG105 TOP view and SIDE view (Unit: mm)	62
Figure 36: TG105 bottom view (Unit: mm)	63
Figure 37: PAD BOTTOM VIEW (Unit: mm)	63
Figure 38: Footprint of recommendation (Unit: mm)	64
Figure 39: Top view of the module	65

Document Title:	TG105/145 Hardware Design
Version:	V1.0
Date:	2009-9-13
Status:	Release
Document Control ID:	TG105/145_HD_V1.0

General Notes

TECHWISH offers this information as a service to its customers, to support application and engineering efforts that use the products designed by TECHWISH. The information provided is based upon requirements specifically provided to TECHWISH by the customers. TECHWISH has not undertaken any independent search for additional relevant information, including any information that may be in the customer's possession. Furthermore, system validation of this product designed by TECHWISH within a larger electronic system remains the responsibility of the customer or the customer's system integrator. All specifications supplied herein are subject to change.

Copyright

This document contains proprietary technical information which is the property of TECHWISH Limited., copying of this document and giving it to others and the using or communication of the contents thereof are forbidden without express authority. Offenders are liable to the payment of damages. All rights reserved in the event of grant of a patent or the registration of a utility model or design. All specification supplied herein are subject to change without notice at any time.

1. Version History

Version	Author	Date	Change Reason	What is new
V1.0	Birthy	2009-9-13	Found	Initial

TECHWISH

2. Introduction

This document defines and specifies the TG105/TG145 module. Please refer to *the chapter 6 Product Information*. This document describes the hardware interface of the TECHWISH TG105/TG145 module that connects to the specific application and the air interface.

This document can help you quickly understand module interface specifications, electrical and mechanical details. With the help of this document and other TG105/TG145 application notes, user guide, you can use TG105/TG145 module to design and set-up mobile applications quickly.

2.1. Related documents

Table 1: Related documents

SN	Document name	Remark
[1]	TG105_ATC	AT_commands set
[2]	ITU-T Draft new recommendation V.25ter:	Serial asynchronous automatic dialing and control
[3]	GSM 07.07:	Digital cellular telecommunications (Phase 2+); AT command set for GSM Mobile Equipment (ME)
[4]	GSM 07.10:	Support GSM 07.10 multiplexing protocol
[5]	GSM 07.05:	Digital cellular telecommunications (Phase 2+); Use of Data Terminal Equipment – Data Circuit terminating Equipment (DTE – DCE) interface for Short Message Service (SMS) and Cell Broadcast Service (CBS)
[6]	GSM 11.14:	Digital cellular telecommunications system (Phase 2+); Specification of the SIM Application Toolkit for the Subscriber Identity module – Mobile Equipment (SIM – ME) interface
[7]	GSM 11.11:	Digital cellular telecommunications system (Phase 2+); Specification of the Subscriber Identity module – Mobile Equipment (SIM – ME) interface
[8]	GSM 03.38:	Digital cellular telecommunications system (Phase 2+); Alphabets and language-specific information
[9]	GSM 11.10	Digital cellular telecommunications system (Phase 2) ; Mobile Station (MS) conformance specification; Part 1: Conformance specification
[10]	AN_ Serial port	The document of serial port application note
[11]	TG105_HD_AN01	The document of TG105 HD application notes

2.2. Terms and abbreviations

Table 2: Terms and abbreviations

Abbreviation	Description
ADC	Analog-to-Digital Converter
AMR	Adaptive Multi-Rate
ARP	Antenna Reference Point
ASIC	Application Specific Integrated Circuit
BER	Bit Error Rate
BTS	Base Transceiver Station
CHAP	Challenge Handshake Authentication Protocol
CS	Coding Scheme
CSD	Circuit Switched Data
CTS	Clear to Send
DAC	Digital-to-Analog Converter
DRX	Discontinuous Reception
DSP	Digital Signal Processor
DTE	Data Terminal Equipment (typically computer, terminal, printer)
DTR	Data Terminal Ready
DTX	Discontinuous Transmission
EFR	Enhanced Full Rate
EGSM	Enhanced GSM
EMC	Electromagnetic Compatibility
ESD	Electrostatic Discharge
ETS	European Telecommunication Standard
FCC	Federal Communications Commission (U.S.)
FDMA	Frequency Division Multiple Access
FR	Full Rate
GMSK	Gaussian Minimum Shift Keying
GPRS	General Packet Radio Service
Abbreviation	Description
GSM	Global Standard for Mobile Communications
HR	Half Rate
I/O	Input/Output
IC	Integrated Circuit
IMEI	International Mobile Equipment Identity
Inorm	Normal Current

Imax	Maximum Load Current
kbps	Kilo bits per second
LED	Light Emitting Diode
Li-Ion	Lithium-Ion
MO	Mobile Originated
MS	Mobile Station (GSM engine), also referred to as TE
MT	Mobile Terminated
PAP	Password Authentication Protocol
PBCCH	Packet Switched Broadcast Control Channel
PCB	Printed Circuit Board
PDU	Protocol Data Unit
PPP	Point-to-point protocol
RF	Radio Frequency
RMS	Root Mean Square (value)
RTC	Real Time Clock
Rx	Receive Direction
SIM	Subscriber Identification Module
SMS	Short Message Service
TDMA	Time Division Multiple Access
TE	Terminal Equipment, also referred to as DTE
TX	Transmitting Direction
UART	Universal Asynchronous Receiver & Transmitter
URC	Unsolicited Result Code
USSD	Unstructured Supplementary Service Data
VSWR	Voltage Standing Wave Ratio
Vmax	Maximum Voltage Value
Vnorm	Normal Voltage Value
Vmin	Minimum Voltage Value
VIHmax	Maximum Input High Level Voltage Value
VIHmin	Minimum Input High Level Voltage Value
Abbreviation	Description
VILmax	Maximum Input Low Level Voltage Value
VILmin	Minimum Input Low Level Voltage Value
VImax	Absolute Maximum Input Voltage Value
VImin	Absolute Minimum Input Voltage Value
VOHmax	Maximum Output High Level Voltage Value
VOHmin	Minimum Output High Level Voltage Value

VOLmax	Maximum Output Low Level Voltage Value
VOLmin	Minimum Output Low Level Voltage Value
Phonebook abbreviations	
FD	SIM fix dialing phonebook
LD	SIM last dialing phonebook (list of numbers most recently dialed)
MC	Mobile Equipment list of unanswered MT calls (missed calls)
ON	SIM (or ME) own numbers (MSISDNs) list
RC	Mobile Equipment list of received calls
SM	SIM phonebook
FWP	Fixed Wireless Phone
FWT	Fixed Wireless Terminal
NC	Not connect

2.3. Safety caution

The following safety precautions must be observed during all phases of the operation. Usage, service or repair of any cellular terminal or mobile incorporating TG105 module. Manufactures of the cellular terminal should send words the following safety information to users and operating personnel and to incorporate these guidelines into all manuals supplied with the product. If not so, TECHWISH does not take on any liability for customer failure to comply with these precautions.



When in a hospital or other health care facility, observe the restrictions about the use of mobiles. Switch the cellular terminal or mobile off, medical equipment may be sensitive to not operate normally for RF energy interference.



Switch off the cellular terminal or mobile before boarding an aircraft. Make sure it be switched off. The operation of wireless appliances in an aircraft is forbidden to prevent interference with communication systems. Forget to think much of these instructions may lead to the flight safety or offend against local legal action, or both.



Do not operate the cellular terminal or mobile in the presence of flammable gases or fumes. Switch off the cellular terminal when you are near petrol stations, fuel depots, chemical plants or where blasting operations are in progress. Operation of any electrical equipment in potentially explosive atmospheres can constitute a safety hazard.



Your cellular terminal or mobile receives and transmits radio frequency energy while switched on. RF interference can occur if it is used close to TV sets, radios, computers or other electric equipment.



Road safety comes first! Do not use a hand-held cellular terminal or mobile when driving a vehicle, unless it is securely mounted in a holder for hands free operation. Before making a call with a hand-held terminal or mobile, park the vehicle.



GSM cellular terminals or mobiles operate over radio frequency signals and cellular networks and cannot be guaranteed to connect in all conditions, for example no mobile fee or a invalid SIM card. While you are in this condition and need emergent help, Please Remember using emergency calls. In order to make or receive calls, the cellular terminal or mobile must be switched on and in a service area with adequate cellular signal strength.

Some networks do not allow for emergency call if certain network services or phone features are in use (e.g. lock functions, fixed dialing etc.). You may have to deactivate those features before you can make an emergency call.

Also, some networks require that a valid SIM card be properly inserted in the cellular terminal or mobile.

3. Product concept

The TG105 is a Dual-band GSM engine that works on frequencies EGSM 900 MHz, DCS 1800 MHz, The TG105 features GPRS multi-slot class 12 (default) / class 10/ class 8 and supports the GPRS coding schemes CS-1, CS-2, CS-3 and CS-4.

With a tiny profile of 33mm x 33mm x 3.45mm, the module can meet almost all the requirements, such as FWP, FWT, PDA phone and other mobile devices.

The physical interface to the mobile application is made through a 68-pin SMT pad, which provides all hardware interfaces between the module and customers' boards.

- The keypad and LCD interface will give you the flexibility to develop customized applications.
- Serial port can help you easily develop your applications.
- Two audio channels include two microphone inputs and two speaker outputs. This can be easily configured by AT command.

The module is designed with power saving technique so that the current consumption is as low as 1.5 mA in SLEEP mode.

The TG105 is integrated with the TCP/IP protocol; extended TCP/IP AT commands are developed for customers to use the TCP/IP protocol easily, which is very useful for those data transfer applications.

The modules are fully RoHS compliant to EU regulation.

3.1. Key features

Table 3: Module key features

Feature	Implementation
Power supply	Single supply voltage 3.4V – 4.5V
Power saving	Typical power consumption in SLEEP mode to 1.5 mA (BS-PA-MFRMS=5)
Frequency bands	<ul style="list-style-type: none"> ● TG105: Dual-band: EGSM 900, DCS 1800 ● TG145: Quad-band: GSM850, EGSM 900, DCS1800, PCS1900. ● The module can search these frequency bands automatically. The frequency bands also can be set by AT command.

	<ul style="list-style-type: none"> ● Compliant to GSM Phase 2/2+
GSM class	Small MS
Transmitting power	<ul style="list-style-type: none"> ● Class 4 (2W) at GSM 850 and EGSM 900 ● Class 1 (1W) at DCS 1800 and PCS 1900
GPRS connectivity	<ul style="list-style-type: none"> ● GPRS multi-slot class 12 (default) ● GPRS multi-slot class 10 (option) ● GPRS multi-slot class 8 (option) ● GPRS mobile station class B
Temperature range	<ul style="list-style-type: none"> ● Normal operation: -20°C to +60°C ● Restricted operation: -30°C to -20°C and +60°C to +80°C [Ⓟ] ● Storage temperature -40°C to +85°C
DATA GPRS:	<ul style="list-style-type: none"> ● GPRS data downlink transfer: max. 85.6 kbps ● GPRS data uplink transfer: max. 85.6 kbps ● Coding scheme: CS-1, CS-2, CS-3 and CS-4 ● Supports the protocols PAP (Password Authentication Protocol) usually used for PPP connections. ● Integrates the TCP/IP protocol. ● Support Packet Switched Broadcast Control Channel (PBCCH)
CSD:	<ul style="list-style-type: none"> ● CSD transmission rates: 2.4, 4.8, 9.6, 14.4 kbps, non-transparent ● Unstructured Supplementary Services Data (USSD) support
SMS	<ul style="list-style-type: none"> ● MT, MO, CB, Text and PDU mode ● SMS storage: SIM card
FAX	Group 3 Class 1
SIM interface	Support SIM card: 1.8V, 3V
Antenna interface	Connected via 50 Ohm antenna pad
Audio features	<p>Speech codec modes:</p> <ul style="list-style-type: none"> ● Half Rate (ETS 06.20) ● Full Rate (ETS 06.10) ● Enhanced Full Rate (ETS 06.50 / 06.60 / 06.80) ● Adaptive multi rate (AMR) ● Echo Cancellation
Serial port and Debug port	<ul style="list-style-type: none"> ● Serial Port: Seven lines on Serial Port Interface ● Serial Port can be used for CSD FAX, GPRS service and send AT command of controlling module. ● Serial Port can use multiplexing function. ● Autobauding supports baud rate from 4800 bps to 115200bps. ● Debug Port: Two lines on Serial Port Interface /TXD and /RXD ● Debug Port only used for debugging
Phonebook management	Support phonebook types: SM, FD, LD, RC, ON, MC.

SIM Application Toolkit	Support SAT class 3, GSM 11.14 Release 99
Real time clock	Implemented
Alarm function	Programmable via AT command
Physical characteristics	Size: 33±0.15 x 33±0.15 x 3.45±0.3mm Weight: 6.6g
Firmware upgrade	Firmware upgrade over serial port

If the module does work in this temperature range, the deviations from the GSM specification may occur. For example, the frequency error or the phase error will increase.

Table 4: Coding schemes and maximum net data rates over air interface

Coding scheme	1 Timeslot	2 Timeslot	4 Timeslot
CS-1:	9.05kbps	18.1kbps	36.2kbps
CS-2:	13.4kbps	26.8kbps	53.6kbps
CS-3:	15.6kbps	31.2kbps	62.4kbps
CS-4:	21.4kbps	42.8kbps	85.6kbps

3.2. Functional diagram

The following figure shows a block diagram of the TG105 module and illustrates the major functional part:

- The GSM baseband engine
- Flash and SRAM
- The GSM radio frequency part
- The SMT pads interface

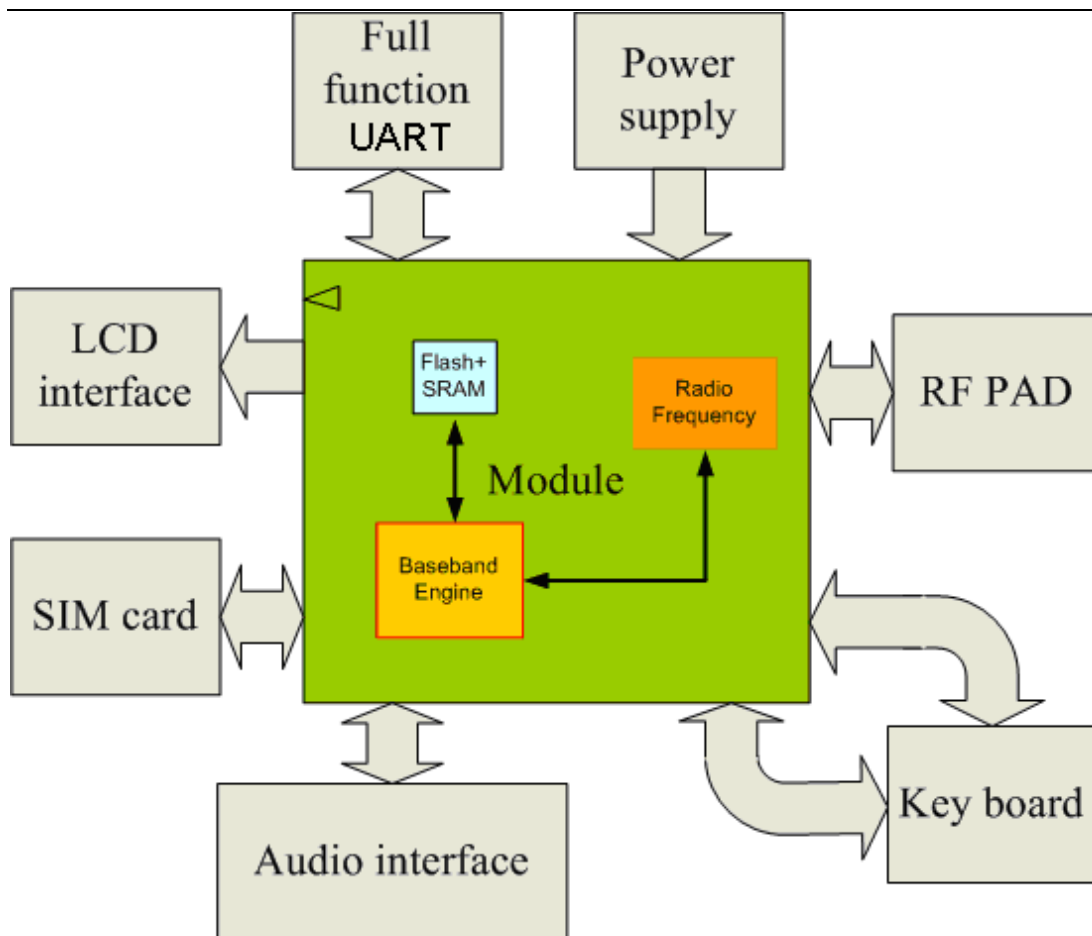

Figure 1: Module functional diagram

3.3. Evaluation board

In order to help you on the application of TG105, TECHWISH can supply an Evaluation Board (EVB) and a link-board that interfaces the module directly with appropriate power supply, SIM card holder, RS232 serial interface, handset port, earphone port, antenna and all GPIOs of the module.

For details, please refer to the *TG105-EVB_UGD* document.

4. Application interface

The module is equipped with a 68-pin 1.5mm pitch SMT pad that connects to the cellular application platform. Sub-interfaces included in these pads are described in detail in following chapters:

- Power supply (refer to Chapter 4.3)
- Serial interfaces (refer to Chapter 4.8)
- Two analog audio interfaces (refer to Chapter 4.9)
- SIM interface (refer to Chapter 4.11)

Electrical and mechanical characteristics of the SMT pad are specified in Chapter 7.

4.1. Pin description

Table 5: Pin description

Power Supply				
PIN NAME	I/O	DESCRIPTION	DC CHARACTERISTICS	COMMENT
VBAT	I	VBAT pins of the SMT pad are dedicated to connect the supply voltage. The power supply of module has to be a single voltage source of VBAT= 3.4V...4.5V. It must be able to provide sufficient current in a transmitting burst which typically rises to 2A. mostly, These 3 pins are voltage inputs	Vmax= 4.5V Vmin=3.4V Vnorm=4.0V	
VRTC	I/O	Current input for RTC when the battery is not supplied for the system. Current output for backup battery when the main battery is present and the backup battery is in low voltage state.	Vmax=2.85V Vmin=2.6V Vnorm=2.75V Iout(max)= 730uA Iin=2.6~5 uA	Recommend to connected to a battery or a capacitor.
VDD_EXT	O	Supply 2.8V voltage for external circuit. By	Vmax=2.9V Vmin=2.7V	1.If unused, keep pin open.

		measuring this pin, user can judge whether the system is power on or off. When the voltage is low, the system is power off. Otherwise, the system is power on.	Vnorm=2.8V Imax=20mA	2. Recommend to add a 2.2~4.7uF bypass capacitor, when using this pin for power supply,
GND		Digital ground		

Power on or power off

PIN NAME	I/O	DESCRIPTION	DC CHARACTERISTICS	
PWRKEY	I	Voltage input for power on key. PWRKEY should be pulled down to power on or power off the system. The user should keep pressing the key for a moment when power on or power off the system. Because the system need margin time in order to assert the software.	VILmax=0.3*VBAT VIHmin=0.7*VBAT VImax=VBAT	Pull up to VBAT Internally.

Audio interfaces

PIN NAME	I/O	DESCRIPTION	DC CHARACTERISTICS	DC
MIC1P MIC1N	I	Positive and negative voice-band input	Audio DC Characteristics refer to chapter 4.9.4	If unused keep pins open
MIC2P MIC2N	I	Auxiliary positive and negative voice-band input		
SPK1P SPK1N	O	Positive and negative voice-band output		If unused keep pin open
SPK2P SPK2N	O	Auxiliary positive and negative audio-band output		If unused keep pins open SPK2N CONNECT TO AGND INTERNALLY
BUZZER	O	Buzzer output		If unused keep pin

				open
AGND		Analog ground		Separate ground connection for external audio circuits. If unused keep pin open
General purpose input/output				
PIN NAME	I/O	DESCRIPTION	DC CHARACTERISTICS	
KBC0~KBC4	O	Keypad interface	$V_{ILmin}=0V$ $V_{ILmax}=0.67V$ $V_{IHmin}=1.7V$ $V_{IHmax}=V_{DD_EXT}+0.3$ $V_{OLmin}=GND$ $V_{OLmax}=0.34V$ $V_{OHmin}=2.0V$ $V_{OHmax}=V_{DD_EXT}$	If unused keep pins open
KBR0~KBR4	I			Pull up to V_{DD_EX} T, if unused keep pins open
DISP_DATA	I/O	LCD display interface		If unused keep pins open
DISP_CLK	O			
DISP_CS	O			
DISP_D/C	O			
DISP_RST	O			
NETLIGHT	O	Network status indication		If unused keep pins open
GPIO0	I/O	Normal input/output port		
GPIO1	I/O	Normal input/output port		
LIGHT_MOS	O	Open drain output port	$I_{max}=150mA$	If unused keep pin open
Serial port				
PIN NAME	I/O	DESCRIPTION	DC CHARACTERISTICS	
DTR	I	Data terminal ready	$V_{ILmin}=0V$ $V_{ILmax}=0.67V$ $V_{IHmin}=1.7V$ $V_{IHmax}=V_{DD_EXT}+0.3$ $V_{OLmin}=GND$	If only use TXD RXD GND to communicate, RTS pin
RXD	I	Receive data		
TXD	O	Transmitting data		
RTS	I	Request to send		
CTS	O	Clear to send		

RI	O	Ring indicator	VOLmax=0.34V VOHmin=2.0V VOHmax= VDD_EXT	should connect to GND directly. If unused keep pins open.
DCD	O	Data carrier detection		
Debug port				
DBG_TXD	O	Serial interface for debugging only.		
DBG_RXD	I		If unused keep pins open	
SIM interface				
PIN NAME	I/O	DESCRIPTION	DC CHARACTERISTICS	
SIM_VDD	O	Voltage supply for SIM card	The voltage can be selected by software automatically either 1.8V or 3V	All signals of SIM interface should be protected against ESD with a TVS diode array. Maximum cable length 200mm from the module pad to SIM card holder.
SIM_DATA	I/O	SIM data output	VIHmin=0.7*SIM_VDD	
SIM_CLK	O	SIM clock	VOHmin=0.8*SIM_VDD	
SIM_RST	O	SIM reset	VOLmax=0.4V	
			When SIM_VDD=3V VILmax=0.4V	
			When SIM_VDD=1.8V VILmax=0.2* SIM_VDD	
			VOHmin=0.9*SIM_VDD	
			When SIM_VDD=3V VOLmax=0.4V	
			When SIM_VDD=1.8V VOLmax=0.2* SIM_VDD	
SIM_PRESENCE	I	SIM card detection	VILmax=0.67V VIHmin=1.7V	If unused , keep pin open.
AUXADC				
PIN NAME	I/O	DESCRIPTION	DC CHARACTERISTICS	
ADC0	I	General purpose analog to digital converter.	voltage range: 0V to 2.8V	If unused keep pin open

4.2. Operating modes

The table below briefly summarizes the various operating modes referred to in the following chapters.

Table 6: Overview of operating modes

Mode	Function	
Normal operation	GSM/GPRS SLEEP	The module will automatically go into SLEEP mode if DTR is set to high level and there is no interrupt (such as GPIO interrupt or data on serial port). In this case, the current consumption of module will reduce to the minimal level. During SLEEP mode, the module can still receive paging message and SMS from the system normally.
	GSM IDLE	Software is active. The module has registered to the GSM network, and the module is ready to send and receive.
	GSM TALK	Connection is going on between two subscribers. In this case, the power consumption depends on network settings such as DTX off/on, FR/EFR/HR, hopping sequences.
	GPRS STANDBY	The module is ready for GPRS data transfer, but no data is currently sent or received. In this case, power consumption depends on network settings and GPRS configuration.
	GPRS DATA	There is GPRS data in transfer (PPP or TCP or UDP). In this case, power consumption is related with network settings (e.g. power control level), uplink / downlink data rates and GPRS configuration (e.g. used multi-slot settings).
POWER DOWN	Normal shutdown by sending the “AT+TPOWD=1” command or using the PWRKEY. The power management ASIC disconnects the power supply from the base band part of the module, and only the power supply for the RTC is remained. Software is not active. The serial interfaces are not accessible. Operating voltage (connected to VBAT) remains applied.	
Minimum functionality mode (without remove power supply)	Use the “AT+CFUN” command can set the module to a minimum functionality mode without remove the power supply. In this case, the RF part of the module will not work or the SIM card will not be accessible, or both RF part and SIM card will be closed all, and the serial interface is still accessible. The power consumption in this case is very low.	
Alarm mode	RTC alert function launches this restricted operation while the module is in POWER DOWN mode. The module will not be registered to GSM network and only parts of AT commands can be available.	

4.3. Power supply

The power supply of module is from a single voltage source of VBAT= 3.4V...4.5V. In some case, the ripple in a transmitting burst may cause voltage drops when current consumption rise to typical peaks of 2A. So the power supply must be able to provide sufficient current up to 2A. For the VBAT input, a local bypass capacitor is recommended. A capacitor (about 100 μ F, low ESR) is recommended. Multi-layer ceramic chip (MLCC) capacitors can provide the best combination of low ESR and small size but may not be cost effective. A lower cost choice may be a 100 μ F tantalum capacitor (low ESR) with a small (0.1 μ F to 1 μ F) ceramic in parallel, which is illustrated as following figure. The capacitors should put as close as possible to the TG105 VBAT pins. The following figure is the recommended circuit.

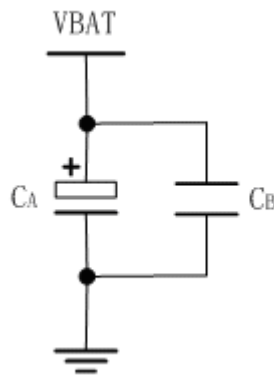

Figure 2: Reference circuit of the VBAT input

The circuit design of the power supply depends strongly from the power source where this power is drained. The following figure is the reference design of +5V input source power supply. The designed output for the power supply is 4.12V, thus a linear regulator can be used. If there's a big difference between the input source and the desired output (VBAT), a switching converter power supply will be preferable because of its better efficiency especially with the 2A peak current in burst mode of the module.

The single 3.6V Li-Ion cell battery type can be connected to the power supply of the module VBAT directly. But the Ni_Cd or Ni_MH battery types must be used carefully, since their maximum voltage can rise over the absolute maximum voltage for the module and damage it.

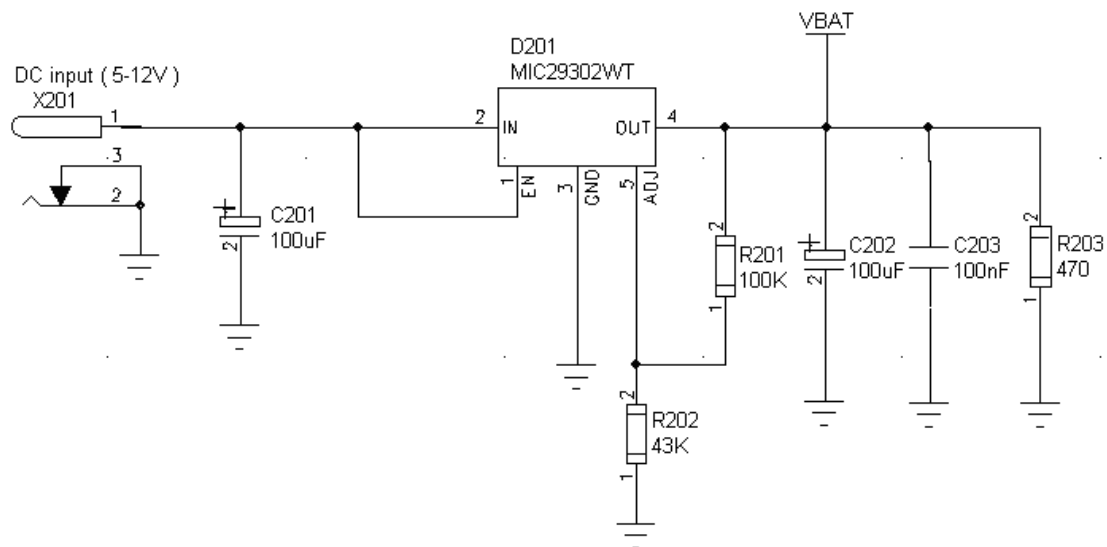

Figure 3: Reference circuit of the source power supply input

The RF Power Amplifier current (2.0A peak in GSM/GPRS mode) flows with a ratio of 1/8 of time, around 577us every 4.615ms. The following figure is the VBAT voltage and current ripple wave at the maximum power transmitting phase, the test condition is VBAT=4.0V, VBAT maximum output current =2A, $C_A=100\mu\text{F}$ tantalum capacitor (ESR=0.7Ω) and $C_B=1\mu\text{F}$.

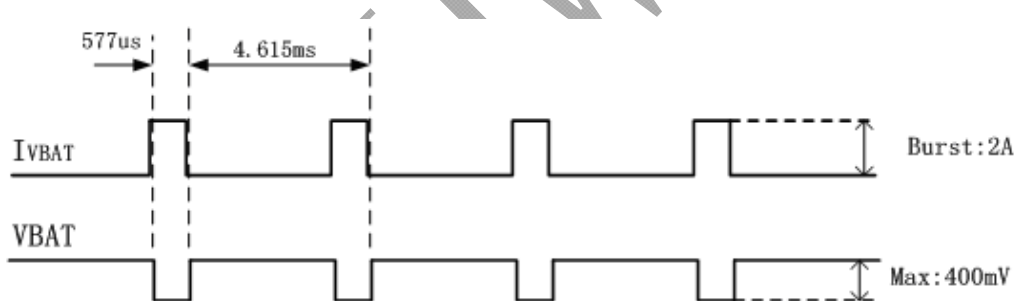

Figure 4: Power supply limits during transmitting burst

4.3.1 Power supply pins

The VBAT pins are dedicated to connect the supply voltage; and the GND pins are recommended for grounding. VRTC pin can be used to back up the RTC.

4.3.2 Minimizing power losses

Please pay special attention to the power supply design for your applications. Please make sure that the input voltage will never drop below 3.4V even in a transmitting burst during which the current consumption may rise up to 2A. If the power voltage drops below 3.4V, the module may

be switched off. The PCB traces from the VBAT pads to the power source must be wide enough to ensure that there isn't too much voltage drop occur in the transmitting burst mode.

4.3.3 Monitoring power supply

To monitor the supply voltage, you can use the "AT+CBC" command which include three parameters: charging status, voltage percent and voltage value (in mV). It returns the battery voltage 1-100 percent of capacity and actual value measured at VBAT and GND.

The voltage is continuously measured at intervals depending on the operating mode. The displayed voltage (in mV) is averaged over the last measuring period before the "AT+CBC" command is executed.

For details please refer to *document [1]*

4.4. Power up and power down scenarios

4.4.1 Turn on

The module can be turned on by various ways, which are described in following chapters:

- Via PWRKEY pin: starts normal operating mode (*please refer to chapter 3.4.1.1*);
- Via RTC interrupt: starts ALARM modes (*please refer to chapter 3.4.1.2*)

Note: The AT command must be set after the module is power on and Unsolicited Result Code "RDY" is received from the serial port. However if the module was set autobauding, the serial port will receive nothing, the AT command can be set after 2-3S from the module is power on. You can use "AT+IPR=x;&W" to set a fix baud rate and save the configuration to non-volatile flash memory. After the configuration was saved as fix baud rate, the Code "RDY" should be received from the serial port all the time when the module was power on. Refer to Chapter "AT+IPR" in document [1].

4.4.1.1 Turn on module using the PWRKEY pin (Power on)

You can turn on the module by driving the PWRKEY to a low level voltage for some time and then released. The simple circuit illustrates as the following figures.

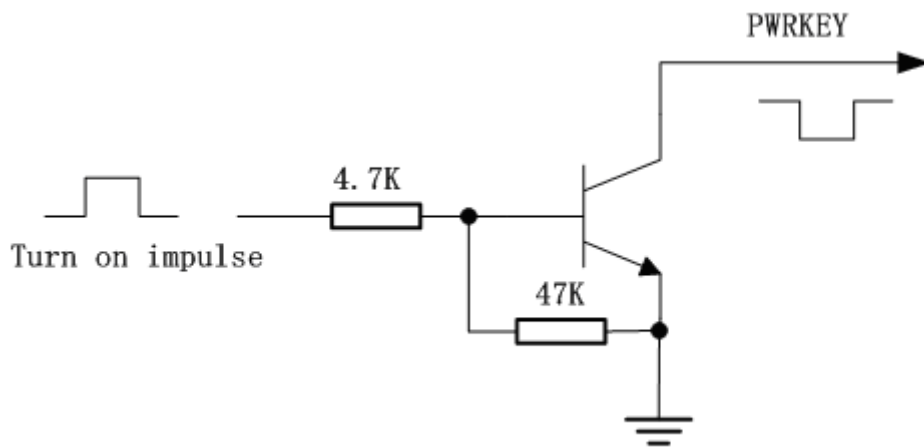

Figure 5: Turn on the module using driving circuit

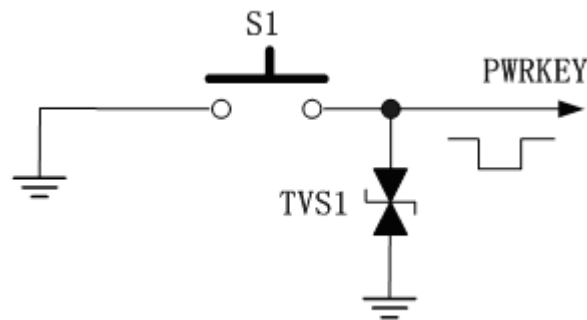

Figure6: Turn on the module using button

The power on scenarios illustrates as following figure.

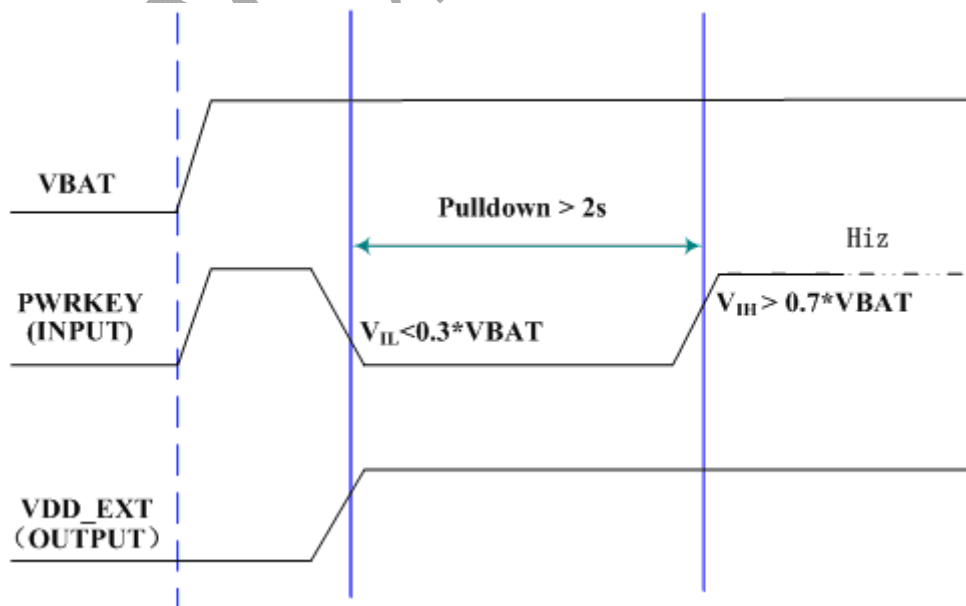

Figure 7: Timing of turn on system

When power on procedure complete, the module will send out following result code to indicate the module is ready to operate when set as fixed baud rate.

RDY

This result code does not appear when autobauding is active.

4.4.1.2 Turn on module using the RTC (Alarm mode)

Alarm mode is a power-on approach by using the RTC. The alert function of RTC makes the module wake up while the module is power off. In alarm mode, the module will not register to GSM network and the software protocol stack is closed. Thus the parts of AT commands related with SIM card and Protocol stack will not be accessible, and the others can be used as well as in normal mode.

Use the “AT+TALARM” command to set the alarm time. The RTC remains the alarm time if the module is power down by “AT+TPOWD=1” or by PWRKEY pin. Once the alarm time is expired and executed, the module will go into the alarm mode. In this case, the module will send out an Unsolicited Result Code (URC) when set as fixed baud rate:

RDY

ALARM MODE

This result code does not appear when autobauding is active.

During alarm mode, use “AT+CFUN” command to query the status of software protocol stack; it will return 0 which indicates that the protocol stack is closed. Then after 90s, the module will power down automatically. However, during alarm mode, if the software protocol is started by “AT+CFUN=1” command, the process of automatic power down will not be available. In alarm mode, driving the PWRKEY to a low level voltage for a period will cause module to power down (Please refer to the power down chapter).

The table follow briefly summarizes the AT commands that are used usually during alarm mode, for details of the instructions refer to *document [1]*:

Table 7: AT commands used in alarm mode

AT command	Use
AT+TALARM	Set alarm time
AT+CCLK	Set data and time of RTC
AT+TPOWD	Power down
AT+CFUN	Start or close the protocol stack

4.4.2 Turn off

Following procedure can be used to turn off the module:

- Normal power down procedure: Turn off module using the PWRKEY pin
- Normal power down procedure: Turn off module using AT command
- Over-voltage or under-voltage automatic shutdown: Take effect if over-voltage or under-voltage is detected

4.4.2.1 Turn off module using the PWRKEY pin (Power down)

You can turn off the module by driving the PWRKEY to a low level voltage for some time. The power down scenario illustrates as following figure.

It can caused the module logoff from the network and allow the software to enter into a secure state and save data before completely disconnect the power supply.

Before the completion of the switching off procedure the module will send out result code:

NORMAL POWER DOWN

After this moment, the AT commands can't be executed. The module enters the POWER DOWN mode, only the RTC is still active. POWER DOWN can also be indicated by VDD_EXT pin, which is a low level voltage in this mode.

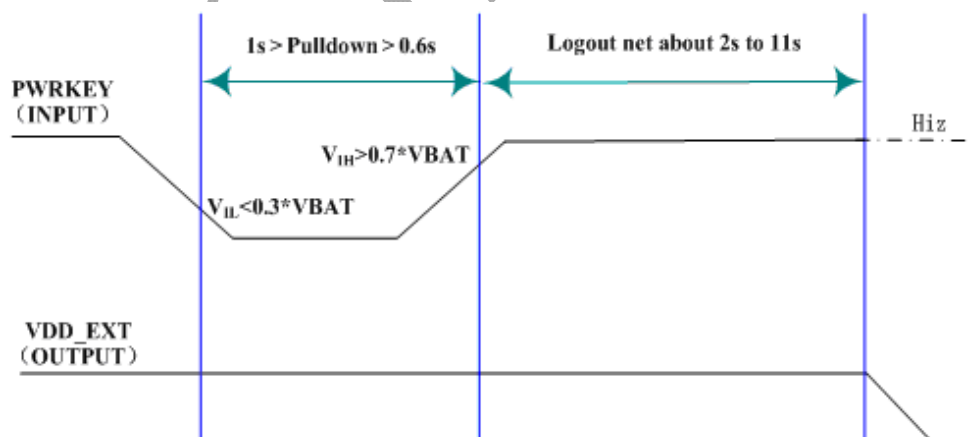

Figure 8: Timing of turn off system

4.4.2.2 Turn off module using AT command

You can use an AT command “AT+TPOWD=1” to turn off the module. This command will let the module to log off from the network and allow the software to enter into a secure state and save data before completely disconnecting the power supply.

Before the completion of the switching off procedure the module will send out result code:

NORMAL POWER DOWN

After this moment, the AT commands can't be executed. The module enters the POWER DOWN mode, only the RTC is still active. POWER DOWN can also be indicated by VDD_EXT pin, which is a low level voltage in this mode.

Please refer to *document [1]* for detail about the AT command of "AT+TPOWD".

4.4.2.3 Over-voltage or under-voltage automatic shutdown

The module will constantly monitor the voltage applied on the VBAT, if the voltage $\leq 3.5V$, the following URC will be presented:

UNDER-VOLTAGE WARNING

If the voltage $\geq 4.5V$, the following URC will be presented:

OVER-VOLTAGE WARNING

The uncritical voltage range is 3.4V to 4.6V. If the voltage $\geq 4.6V$ or $\leq 3.4V$, the module will be automatic shutdown soon.

If the voltage $\leq 3.4V$, the following URC will be presented:

UNDER-VOLTAGE POWER DOWN

If the voltage $\geq 4.6V$, the following URC will be presented:

OVER-VOLTAGE POWER DOWN

After this moment, no further more AT commands can be executed. The module logs off from network and enters POWER DOWN mode, and only RTC is still active. POWER DOWN can also be indicated by VDD_EXT pin, which is a low level voltage in this mode.

4.4.3 Restart module using the PWRKEY pin

You can restart module by driving the PWRKEY to a low level voltage for some time, same as turn on module using the PWRKEY pin. Before restarting the module, you need delay at least 500ms from detecting the VDD_EXT low level on. The restart scenario illustrates as the following figure.

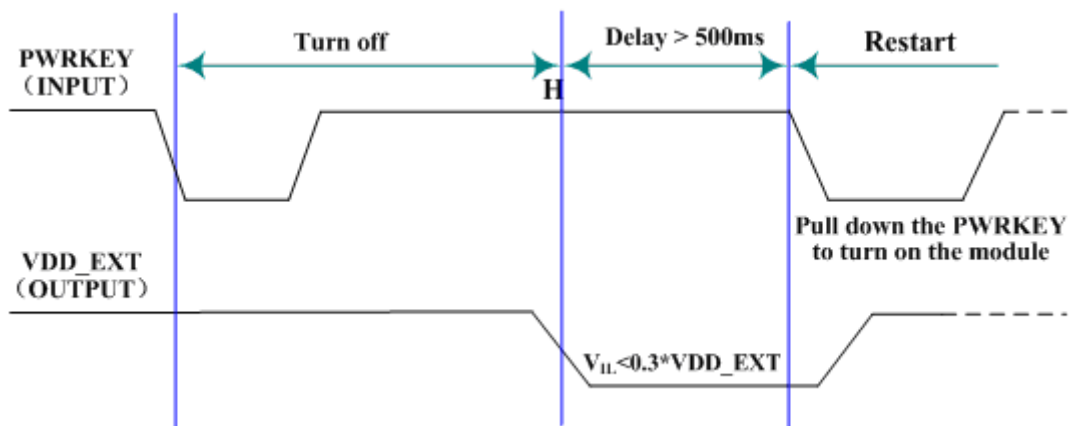

Figure 9 : Timing of restart system

4.5. Power saving

There are two methods for the module to enter into low current consumption status. “AT+CFUN” is used to set module into minimum functionality mode and DTR hardware interface signal can be used to lead system to be sleep mode (or slow clocking mode).

4.5.1 Minimum functionality mode

Minimum functionality mode reduces the functionality of the module to a minimum and, thus, minimizes the current consumption to the lowest level. This mode is set with the “AT+CFUN” command which provides the choice of the functionality levels $\langle \text{fun} \rangle = 0, 1, 4$.

- 0: minimum functionality;
- 1: full functionality (default);
- 4: disable phone both transmitting and receive RF circuits;

If the module has been set to minimum functionality by “AT+CFUN=0”, the RF function and SIM card function will be closed. In this case, the serial port is still accessible, but all AT commands correlative with RF function or SIM card function will not be accessible.

If the module has been set by “AT+CFUN=4”, the RF function will be closed, the serial port is still active. In this case, all AT commands correlative with RF function will not be accessible.

After the module has been set by “AT+CFUN=0” or “AT+CFUN=4”, it can return to full functionality by “AT+CFUN=1”.

For detailed information about “AT+CFUN”, please refer to *document [1]*.

4.5.2 Sleep mode (slow clock mode)

We can control module to enter or exit the sleep mode in customer applications through DTR signal. When DTR is in high level, and there is no on air and hardware interrupt (such as GPIO interrupt or data on serial port), the module will enter SLEEP mode automatically. In this mode, the module can still receive paging or SMS from network but the serial port is not accessible.

Note: For module, it requests to set AT command “AT+TSCLK=1” to enable the sleep mode; the default value is 0, that can’t make the module enter sleep mode. For more details, please refer to our AT command list.

4.5.3 Wake up module from SLEEP mode

When the module is in SLEEP mode, the following methods can wake up the module.

- Enable DTR pin to wake up.
If DTR Pin is pulled down to a low level, this signal will wake up module from power saving mode. The serial port will be active after DTR changed to low level about 20ms.
- Receiving a voice or data call from network to wake up module.
- Receiving a SMS from network to wake up module.
- RTC alarm expired to wake up module.
- Keypad and PWRKEY interrupt

Note: DTR pin should be held low level during communicating between the module and DTE.

4.6. Summary of state transitions (except SLEEP mode)

Table 8: Summary of state transitions

Further mode	POWER DOWN	Normal mode	Alarm mode
Current mode			
POWER DOWN		Use PWRKEY	Switch on from POWER DOWN mode by RTC
Normal mode	AT+TPOWD or use PWRKEY pin		Set alarm by “AT+TALARM”, and then switch off the module. When the timer expire, the module turn on and enter Alarm mode
Alarm mode	Use PWRKEY pin or wait module switch off automatically	Use AT+CFUN	

4.7. RTC backup

The RTC (Real Time Clock) power supply of module can be provided by an external capacitor or battery (rechargeable or non-chargeable) through the VRTC on the SMT pad. There is a 3.9 K resistor has been integrated in the module used for limiting current. You need only a coin-cell battery or a super-cap to VRTC to backup power supply for RTC.

Note: The VRTC couldn't be designed to a NC pin in your circuit. You should connect the VRTC pin to a battery or a capacitor.

The following figures show various sample circuits for RTC backup.

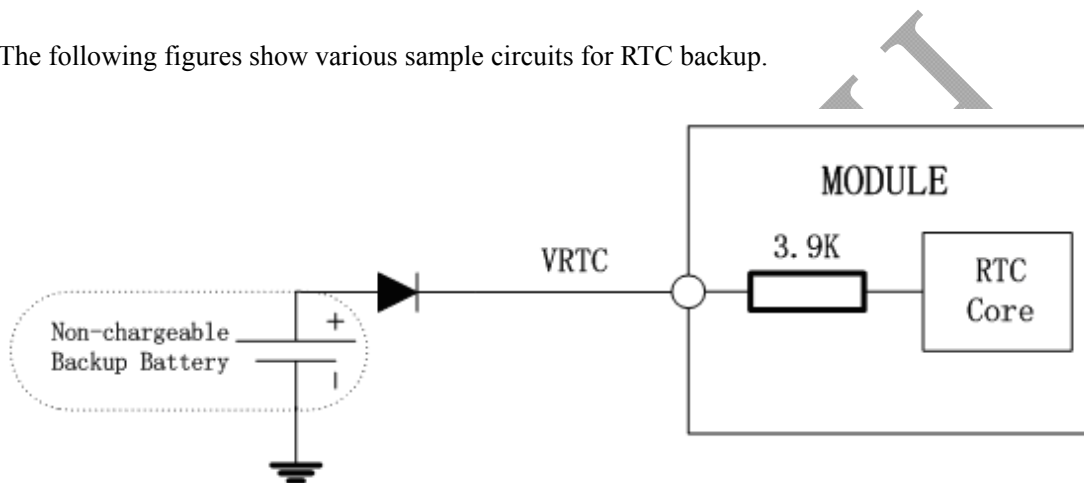

Figure 10: RTC supply from non-chargeable battery

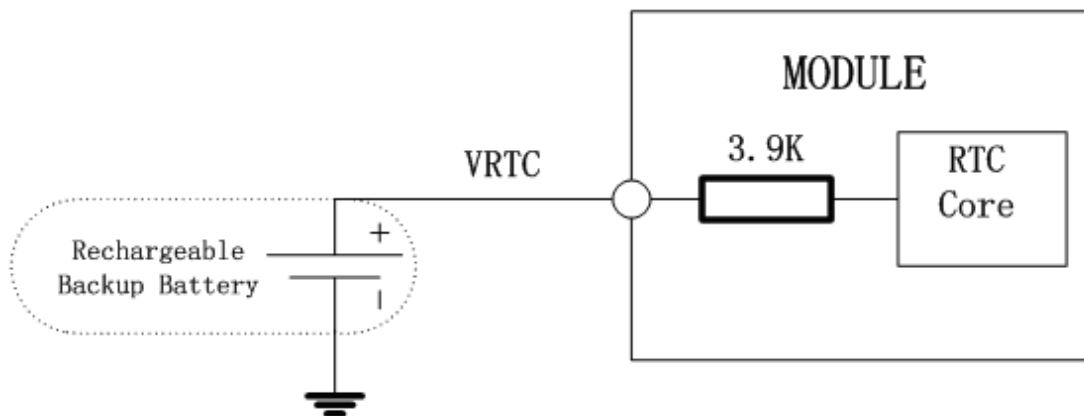

Figure 11: RTC supply from rechargeable battery

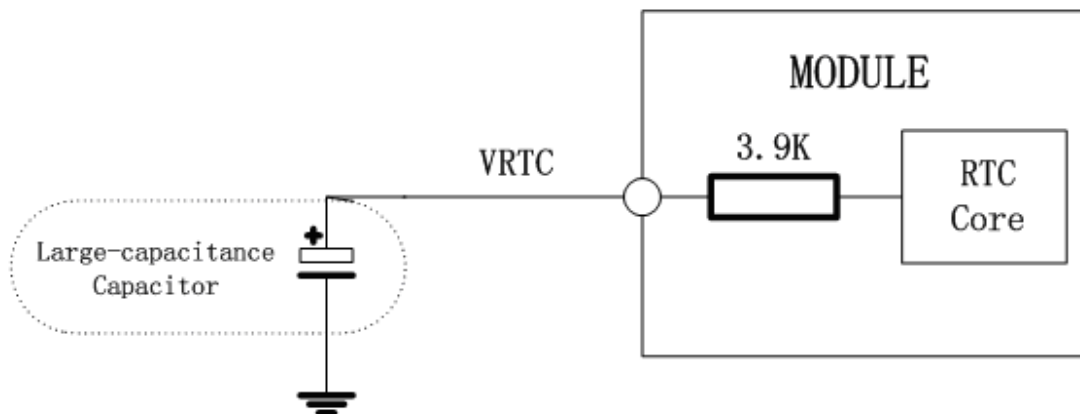

Figure 12: RTC supply from capacitor

- **Coin-type Capacitor backup**

Coin-type Rechargeable Capacitor such as XH414H-IV01E form Seiko can be used.

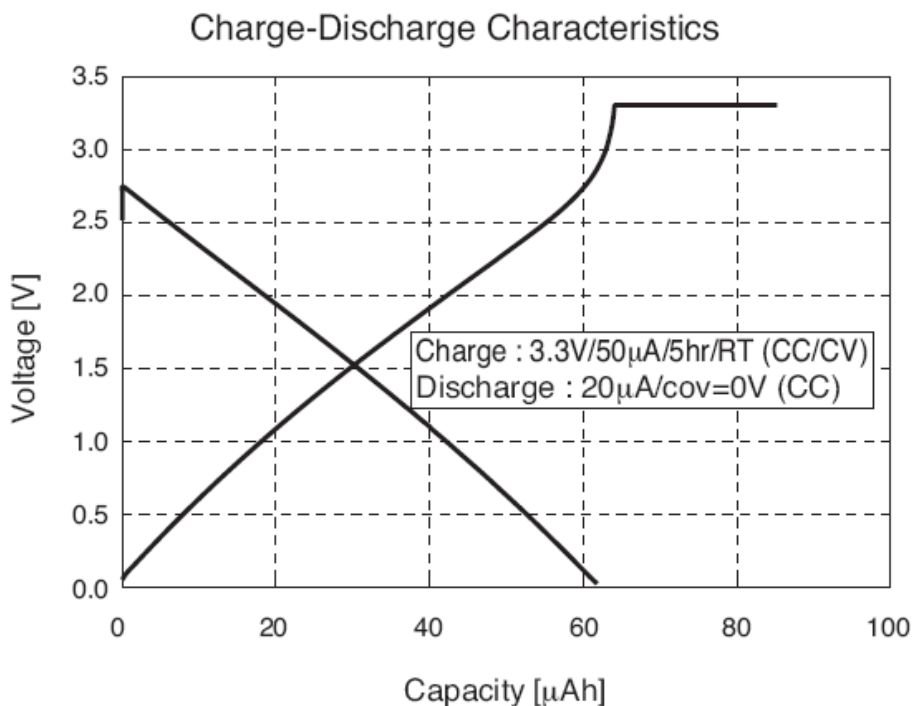

Figure 13: Seiko XH414H-IV01E Charge Characteristic

4.8. Serial interfaces

The module provides two unbalanced asynchronous serial ports. One is the serial port ,the other is the debug port. The module is designed as a DCE (Data Communication Equipment), following the traditional DCE-DTE (Data Terminal Equipment) connection. The module and the client (DTE) are connected through the following signal (as following figure shows). Autobauding supports baud rate from 4800bps to 115200bps.

Serial port

- TXD: Send data to the RXD signal line of the DTE
- RXD: Receive data from the TXD signal line of the DTE

Debug port

- DBG_TXD: Send data to the /RXD signal line of the DTE
- DBG_RXD: Receive data from the /TXD signal line of the DTE

The serial interfaces have 2 mA drive. The logic levels are described in following table

Table 9: Logic levels of the serial port and debug port

Parameter	Min	Max	Unit
V _{IL}	0	0.67	V
V _{IH}	1.67	VDD_EXT +0.3	V
V _{OL}	GND	0.34	V
V _{OH}	2.0	VDD_EXT	V

Table 10: Pin definition of the serial interfaces

	Name	Pin	Function
Debug port	DBG_TXD	41	Transmitting data of the debug port
	DBG_RXD	42	Receive data of the debug port
Serial port	RI	61	Ring indicator
	RTS	62	Request to send
	CTS	63	Clear to send
	RXD	65	Receive data of the serial port
	TXD	66	Transmitting data of the serial port
	DTR	67	Data terminal ready
	DCD	68	Data carrier detection

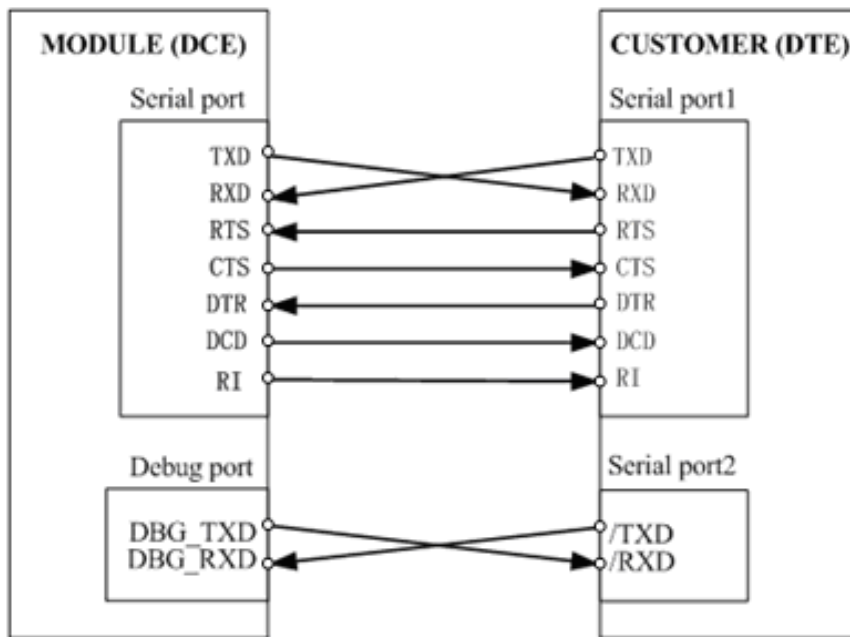

Figure 14: Connection of serial interfaces

Note: The RTS PIN must be connected to the GND in the customer circuit when only the TXD and RXD are used in the Serial Port communication.

4.8.1 Function of serial port & debug port supporting

Serial port

- Seven lines on Serial Interface.
- Contains Data lines TXD and RXD, State lines RTS and CTS, Control lines DTR, DCD and RI.
- Serial Port can be used for CSD FAX, GPRS service and send AT command of controlling module. Also Serial Port can be used for multiplexing function. The module supports only basic mode of multiplexing so far.
- Serial Port supports the communication rates as following:
110,300,1200, 2400, 4800, 9600, 19200, 38400, 57600, 115200 Default as 115200bps.
- Autobauding supports the communication rates as following:
4800, 9600, 19200, 38400, 57600 and 115200bps.

After setting the fixed baud rate or Autobauding, please send “AT” command at that rate, the serial port is available when it respond “OK”. Autobauding is not compatible with multiplex mode.

Autobauding allows the GSM engine to automatically detect the baud rate configured in the host application. The serial port of the GSM engine supports autobauding for the following baud rates: 4800, 9600, 19200, 38400, 57600, 115200bps. Factory setting is autobauding enabled. This gives you the flexibility to put the GSM engine into operation no matter what baud rate your host application is configured to. To take advantage of autobauding mode, specific attention should be

paid to the following requirements:

Synchronization between DTE and DCE:

When DCE powers on with the autobauding enabled, it is recommended to wait 2 to 3 seconds before sending the first AT character. After receiving the “OK” response, DTE and DCE are correctly synchronized.

Restrictions on autobauding operation

- The serial port has to be operated at 8 data bits, no parity and 1 stop bit (factory setting).
- The Unsolicited Result Codes like "RDY", "+CFUN: 1" and "+CPIN: READY" are not indicated when you start up the ME while autobauding is enabled. This is due to the fact that the new baud rate is not detected unless DTE and DCE are correctly synchronized as described above.

Note: You can use “AT+IPR=x;&W” to set a fixed baud rate and save the configuration to non-volatile flash memory. After the configuration is saved as fixed baud rate, the Unsolicited Result Codes like "RDY" should be received from the serial port all the time when the module is power on.

Debug port

- Two lines on Serial Port Interface
- Only contains Data lines DBG_TXD and DBG_RXD
- Debug Port is only used for debugging. It cannot be used for CSD call, FAX call, GPRS service, AT command and the Debug port can not be use multiplexing function. It does not support autobauding function.

4.8.2 Software upgrade and software debug

The TXD, RXD, DBG_TXD, DBG_RXD and GND must be connected to the IO when user need to upgrade software and debug software, the TXD、RXD should be used for software upgrade and the DBG_TXD、DBG_RXD for software debugging. The PWRKEY pin is recommended to connect to the IO. The user also can add a switch between the PWRKEY and the GND. The PWRKEY should be connected to the GND when module is upgrading software. Please refer to the following figures.

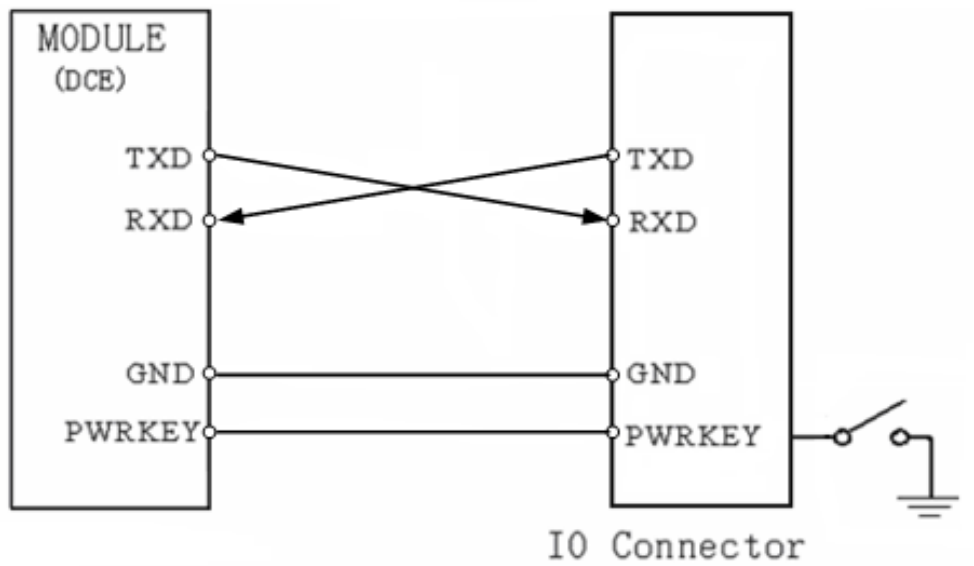

Figure 15: Connection of software upgrade

Note: The RTS PIN must be connected to the GND in the customer circuit when only the TXD and RXD are used in the Serial Port communication.

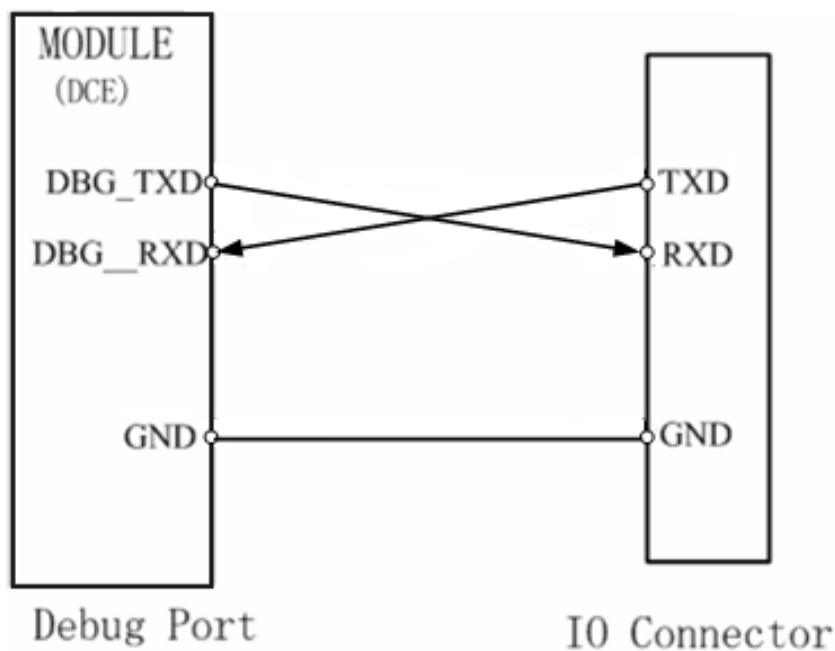

Figure 16: Connection of software debug

The serial port and the debug port don't support the RS_232 level and it only supports the CMOS level. You should add the level converter IC between the DCE and DTE. If you connect it to the computer, Please refer to the following figure.

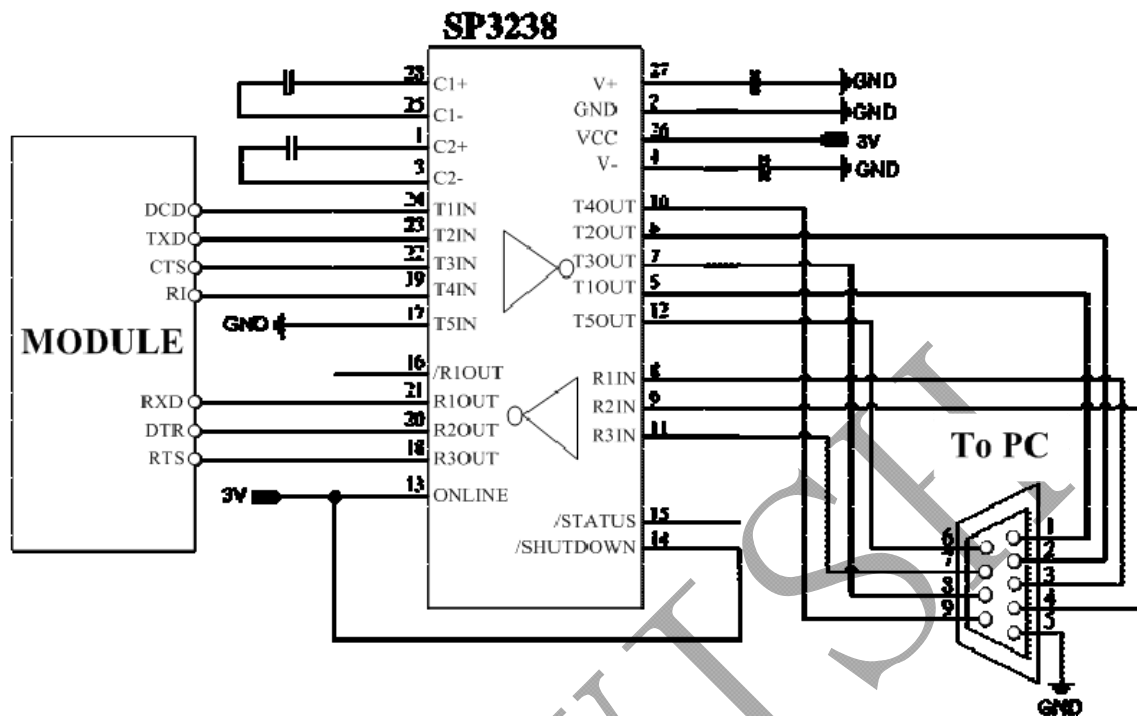

Figure 17: RS232 level converter circuit

Note 1: For detail information about serial port application, please refer to document [10]

Note 2: The following pins (VBAT/RXD/TXD/GND/PWRKEY) must be reserved for firmware upgrade.

4.9. Audio interfaces

The module provides two analog input channels and two analog output channels on these SMT pads.

- AIN1 and AIN2, which may be used for both microphone and line inputs. The electret microphone is recommended when the interface used for microphone. One of the two channels is typically used with a microphone built into a handset. The other channel is typically used with an external microphone. AIN1 is a differential channel, AIN2 is also a differential mode. The module analog input configuration is determined by control register settings and established using analog multiplexes.
- AOUT1 and AOUT2, which may be used for both receiver and speaker outputs. AOUT1 channel is typically used with a receiver built into a handset. The other channel is typically used with speaker which is for handsfree audio output. AOUT1 channel is a differential channel and AOUT2 is a single-ended channel, SPK2P and SPK2N which connect to AGND internal can establish a pseudo differential mode. There isn't any capacitor connected with SPK2P line in the module, so the output of SPK2P is a DC voltage, user should add a

capacitor (The 22uF capacitor is recommended) which usually for block the DC voltage in the single-end mode. The module analogy output configuration is determined by control register settings and established using analogy multiplexes.

- These two analogy channels can be easily swapped by “AT+TCHFA” command. For more details, please refer to document [1].
- For each channels, you can use AT+TMIC to adjust the input gain level of microphone, you can also use “AT+CLVL” to adjust the output gain level of receiver and speaker. “AT+TECHO” is to set the parameters for echo cancellation control. Also “AT+TSIDET” is to set the side-tone gain level, use “AT+TCHFA” to activate one of the two audio channels and deactivate the other one. For details, please refer to document [1].

Note:

- **Use AT command “AT+TCHFA” to select audio channel:**
0--AIN1/AOUT1 (normal audio channel), the default value is 0.
1--AIN2/AOUT2 (aux_audio channel) .

Table 11: Pin definition of Audio interface

	Name	Pin	Function
(AIN1/AOUT1)	MIC1P	18	Microphone1 input +
	MIC1N	19	Microphone1 input -
	SPK1P	21	Audio1 output+
	SPK1N	20	Audio1 output-
(AIN2/AOUT2)	MIC2P	22	Microphone2 input +
	MIC2N	23	Microphone2 input -
	SPK2P	17	Audio2 output+
	SPK2N	16	Audio2 output- Connect to AGND Internally

It is suggested that you adopt the one of following matching circuits in order to improve audio performance. The difference audio signals have to be layout according to differential signal layout rules. As show in following figures (**Note: all components package are 0603.**) If you want to adopt an amplifier circuit for audio, we recommend Texas Instruments’s TPA6205A1 which is a fully differential amplifier. Of course, you can select it according to your requirement.

4.9.1 Speaker interface configuration

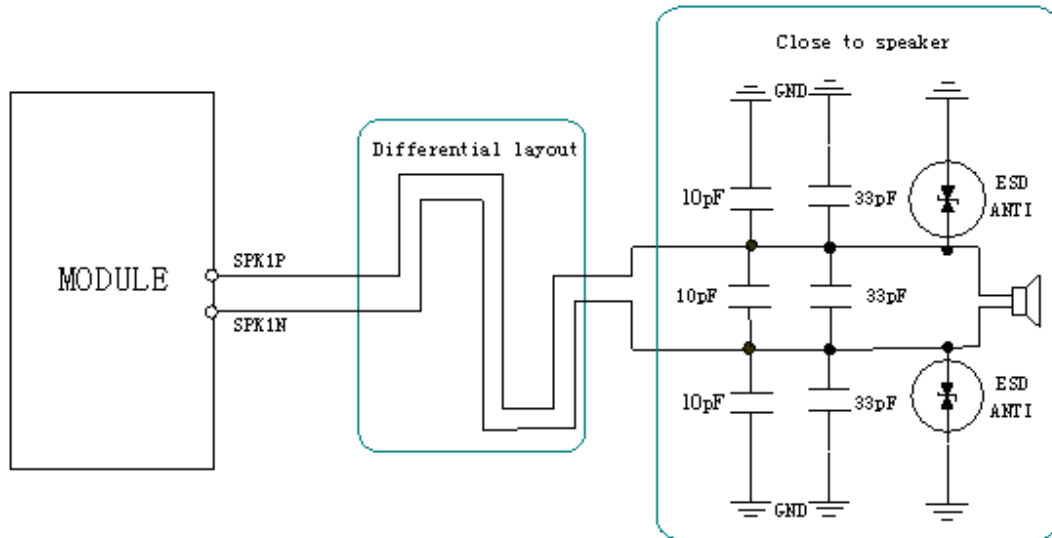

Figure 18: Speaker interface configuration of AOUT1

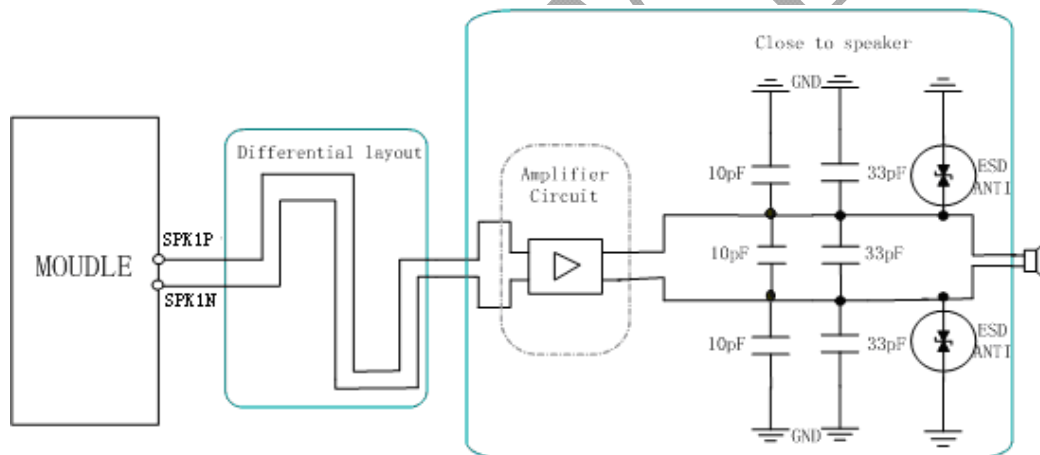

Figure 19: Speaker interface with amplifier configuration of AOUT1

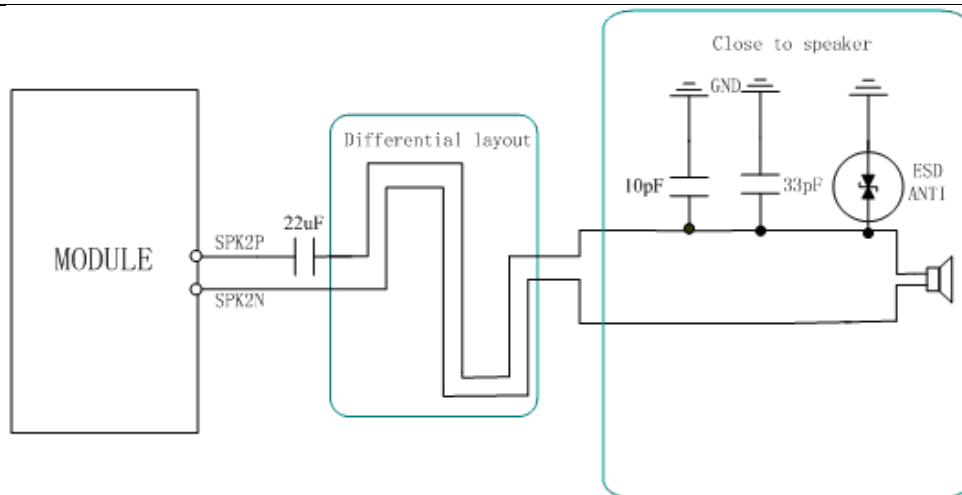

Figure 20: Speaker interface configuration of AOUT2

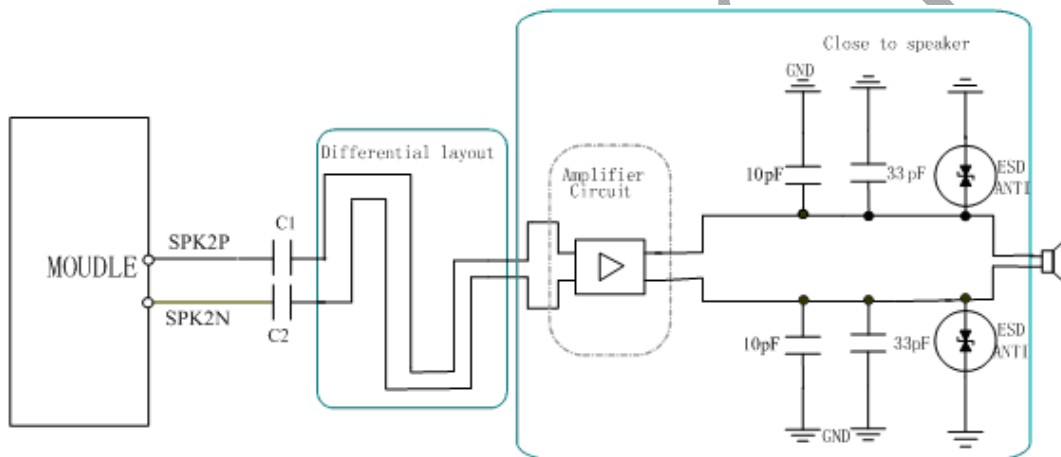

Figure 21: Speaker interface with amplifier configuration of AOUT2

Note: The value of C1 and C2 depends on the input impedance of audio Amplifier.

4.9.2 Microphone interfaces configuration

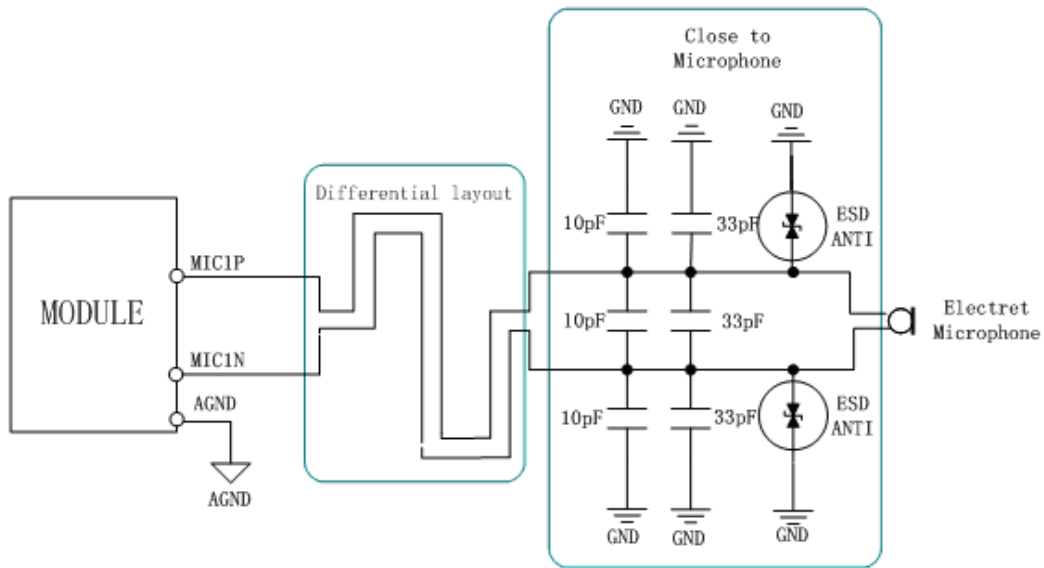

Figure 22: Microphone interface configuration

4.9.3 Earphone interface configuration

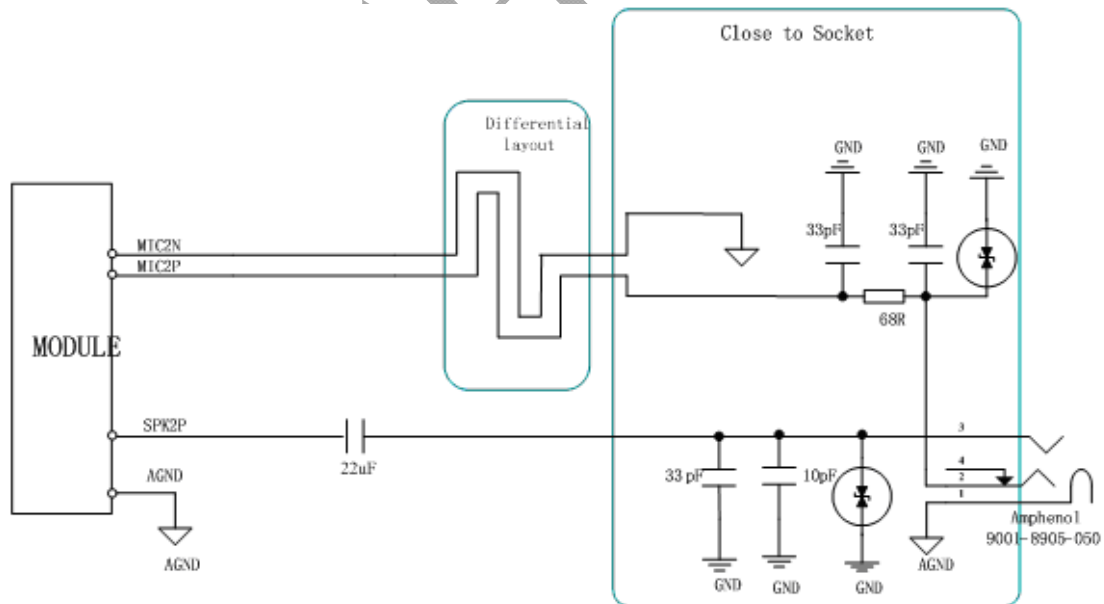

Figure 1: Earphone interface configuration

Table 12: MIC input characteristics

Parameter	Min	Typ	Max	Unit
Working Voltage	1.2	1.5	2.0	V
Working Current	200		500	uA
External Microphone Load Resistance		2.2		k Ohm

Table 13: SPK Output Characteristics

Parameter			Min	Typ	Max	Unit
Normal Output(SPK1)	Single Ended	load Resistance	28	32		Ohm
		Ref level	0		2.4	Vpp
	Differential	load Resistance	28	32		Ohm
		Ref level	0		4.8	Vpp
Auxiliary Output(SPK2)	Single Ended	load Resistance	16	32		Ohm
		Ref level	0		2.4	Vpp
Maxim driving current limit of SPK1 and SPK2					50	mA

4.10. Buzzer

The BUZZER on the SMT pads can be used to drive a buzzer to indicate incoming call. The output volume of buzzer can be set by "AT+CRSL". The reference circuit for buzzer shown as following figure:

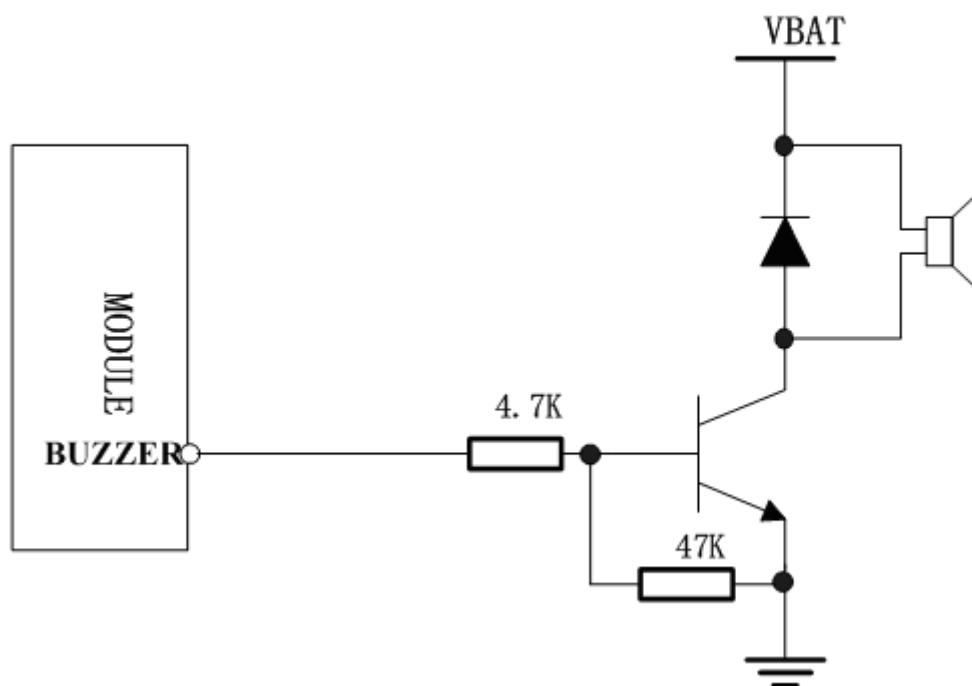

Figure 23: Reference circuit for Buzzer

Table 14: Pin definition of the Buzzer

Name	Pin	Function
Buzzer	60	Output of buzzer tone

Table 15: Buzzer Output Characteristics

Parameter	Min	Typ	Max	Unit
Working Voltage	2.0	2.8	VDD_VEXT	V
Working Current			4	mA

4.11. SIM card interface

4.11.1 SIM card application

You can use AT Command to get information in SIM card. For more information, please refer to *document [1]*.

The SIM interface supports the functionality of the GSM Phase 1 specification and also supports the functionality of the new GSM Phase 2+ specification for FAST 64 kbps SIM (intended for use with a SIM application Tool-kit).

Both 1.8V and 3.0V SIM Cards are supported.

The SIM interface is powered from an internal regulator in the module having normal voltage 3V. All pins reset as outputs driving low. Logic levels are as described in table

Table 16: Pin definition of the SIM interface

Name	Pin	Function
SIM_VDD	13	SIM Card Power output automatic output on SIM mode, one is 3.0V±10%, another is 1.8V±10%. Current is about 10mA.
SIM_DATA	10	SIM Card data I/O
SIM_CLK	11	SIM Card Clock
SIM_RST	12	SIM Card Reset
SIM_PRESENCE	28	SIM Card Presence

Following is the reference circuit about SIM interface. We recommend an Electro-Static discharge device ST (www.st.com) ESDA6V1W5 or ON SEMI (www.onsemi.com) SMF05C for “ESD ANTI”. The 22Ω resistors showed in the following figure should be added in series on the IO line between the module and the SIM card for protecting the SIM I/O port. Note that the SIM peripheral circuit should be closed to the SIM card socket.

The SIM_PRESENCE pin is used for detecting the SIM card removal. You can use the AT command “AT+TSDT” to set the SIMCARD configuration. For detail of this AT command, please refer to *document [1]*:

You can select the 8 pins SIM card holder. The reference circuit about 8 pins SIM card holder illustrates as following figure.

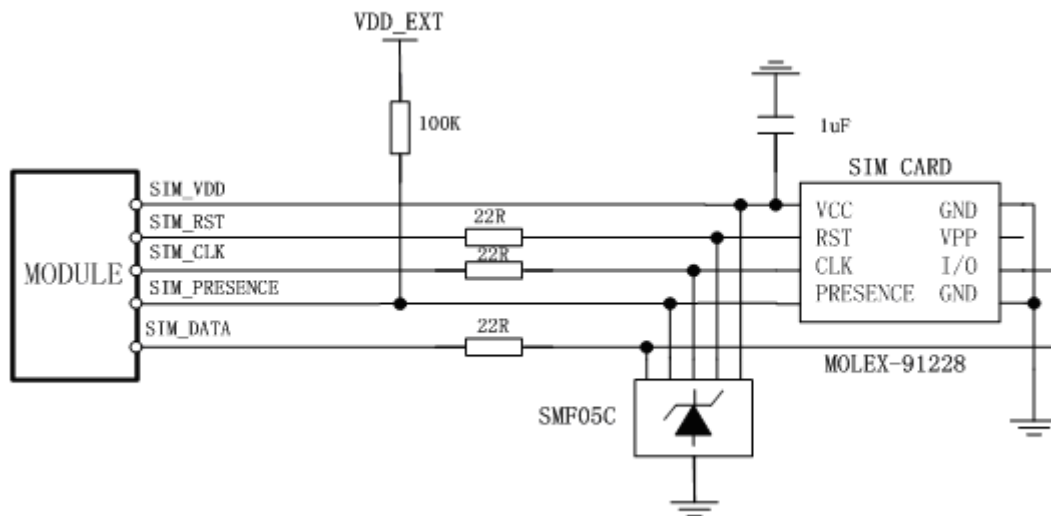

Figure 24: Reference circuit of the 8 pins SIM card

If you don't use the SIM card detection function, you can let the SIM_PRESENCE open. The reference circuit about 6 pins SIM card illustrates as following figure.

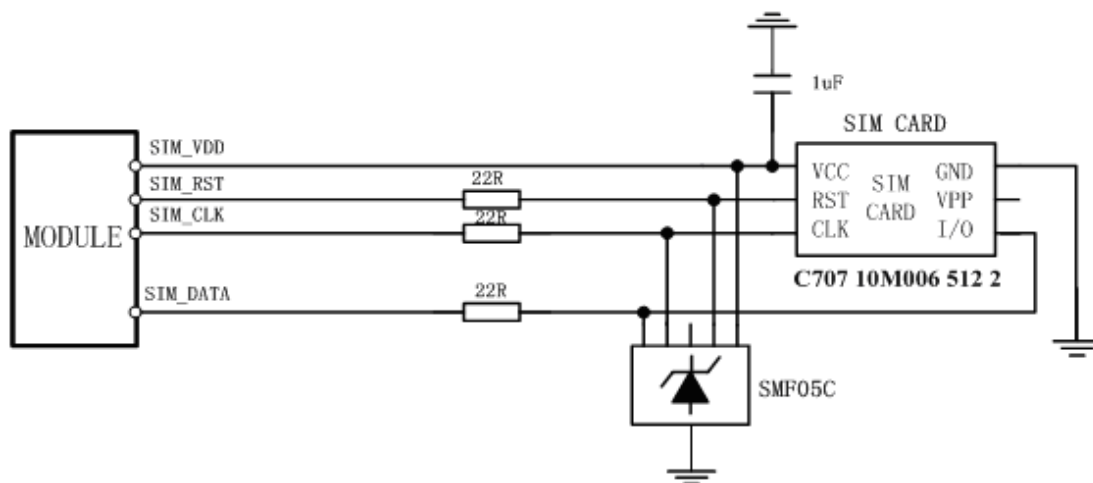

Figure 25: Reference circuit of the 6 pins SIM card

4.11.2 Design considerations for SIM card holder

For 6 pins SIM card holder, we recommend to use Amphenol C707 10M006 512 2 .You can visit <http://www.amphenol.com> for more information about the holder.

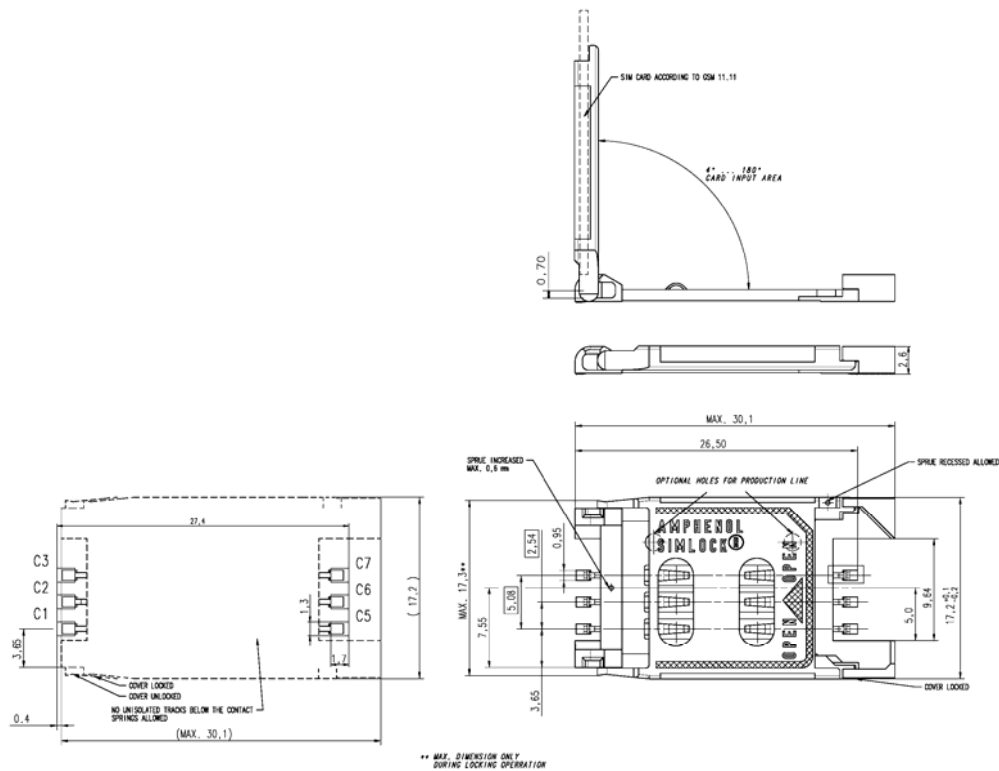

Figure 26: Amphenol C707 10M006 512 2 SIM card holder

Table 17: Pin description (Amphenol SIM card holder)

Name	Pin	Function
SIM_VDD	C1	SIM Card Power supply, it can identify automatically the SIM Card power mode, one is $3.0V \pm 10\%$, another is $1.8V \pm 10\%$. Current is about 10mA.
SIM_RST	C2	SIM Card Reset.
SIM_CLK	C3	SIM Card Clock.
GND	C5	Connect to GND.
VPP	C6	Not connect.
SIM_DATA	C7	SIM Card data I/O.

For 8 pins SIM card holder, we recommend to use Molex 91228. You can visit <http://www.molex.com> for more information about the holder.

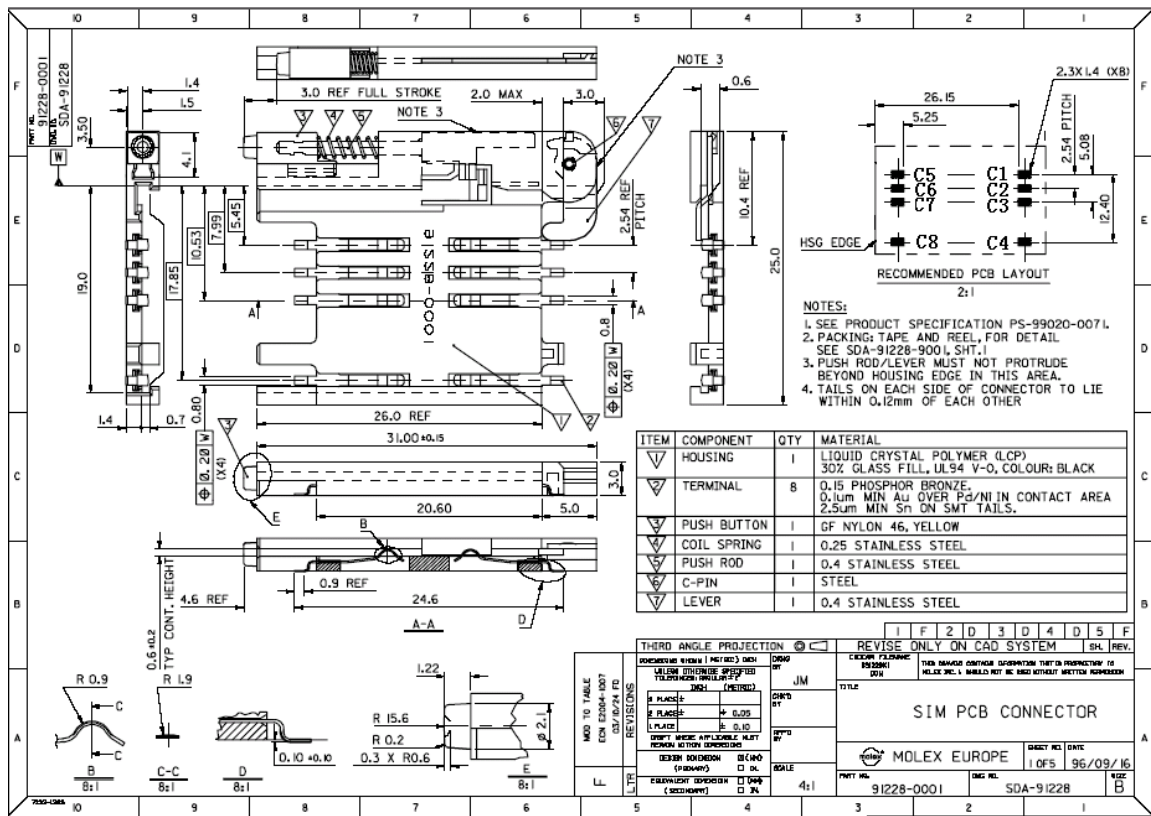

Figure 27: Molex 91228 SIM card holder

Table 18: Pin description (Molex SIM card holder)

Name	Pin	Function
SIM_VDD	C1	SIM Card Power supply, it can identify automatically the SIM Card power mode, one is 3.0V±10%, another is 1.8V±10%. Current is about 10mA.
SIM_RST	C2	SIM Card Reset
SIM_CLK	C3	SIM Card Clock
GND	C4	Connect to GND
GND	C5	Connect to GND
VPP	C6	Not connect
SIM_DATA	C7	SIM Card data I/O
SIM_PRESENCE	C8	Detect SIM Card Presence

4.12. LCD interface

The module contains a versatile LCD controller which is optimized for multimedia applications. This controller supports many types of LCD modules including monochrome

LCD, color LCD. It contains a rich feature set to enhance the functionality, These features are:

- Up to 176x220 resolution
- Supports 8-bpp (RGB332), 12-bpp (RGB444), 16-bpp (RGB565) color depths

The serial LCD display interface supports serial communication with LCD device. When used as LCD interface, the following table is the pin definition. LCD interface timing should be united with the LCD device.

Table 19: Pin definition of the LCD interface

Name	Pin	Function
DISP_RST	3	LCD reset
DISP_D/C	4	Display data or command select
DISP_CS	5	Display enable
DISP_CLK	6	Display clock for LCD
DISP_DATA	7	Display data output

Note: This function is not supported in the default firmware. There must be some special firmware if you want. Please contact TECHWISH for more details.

4.13. Keypad interface

The keypad interface consists of 5 keypad column outputs and 5 keypad row inputs. The basic configuration is 5 keypad columns and 5 keypad rows, giving 25 keys.

Table 20: Pin definition of the keypad interface

Name	Pin	Function
KBC0	35	Keypad matrix column
KBC1	36	
KBC2	37	
KBC3	38	
KBC4	39	
KBR0	30	Keypad matrix row
KBR1	31	
KBR2	32	
KBR3	33	
KBR4	34	

The keypad interface allows a direct external matrix connection. A typical recommended circuit about the keypad is as shown in the following figure.

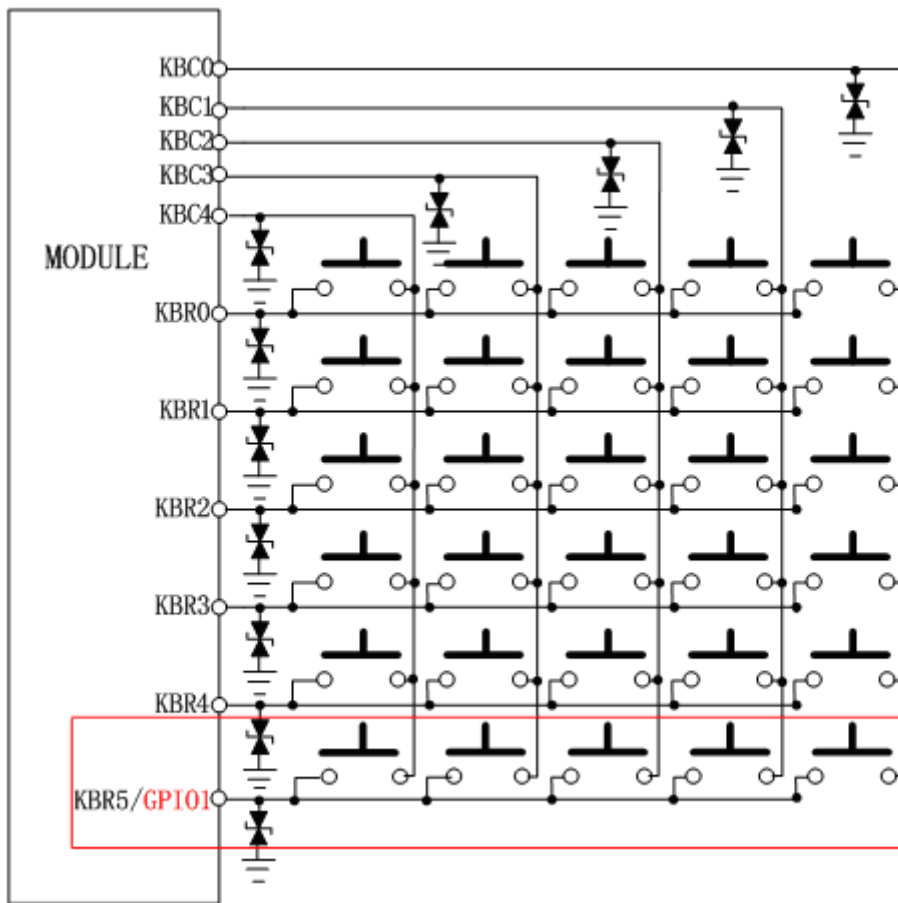

Figure 28: Reference circuit of the keypad interface

If 5X5 matrix couldn't provide enough keys, we advise you to configure 5X6 matrix using of GPIO1 as the KBR5. And then, the keypad interface can consists of 6 keypad column outputs and 5 keypad row inputs. The basic configuration is 6 keypad columns and 5 keypad rows, giving 30 keys.

Note: This function is not supported in the default firmware. There must be special firmware if you want. Please contact TECHWISH for more details.

4.14. ADC

The module provides two auxiliary ADC to measure the values of voltage. AT command "AT+TADC" to read the voltage value added on ADC pin. For detail of this AT command, please refer to *document [1]*.

Table 21: Pin definition of the ADC

Name	Pin	Function
ADC0	52	Analog to digital converter.
TEMP_BAT	43	Analog to digital converter.

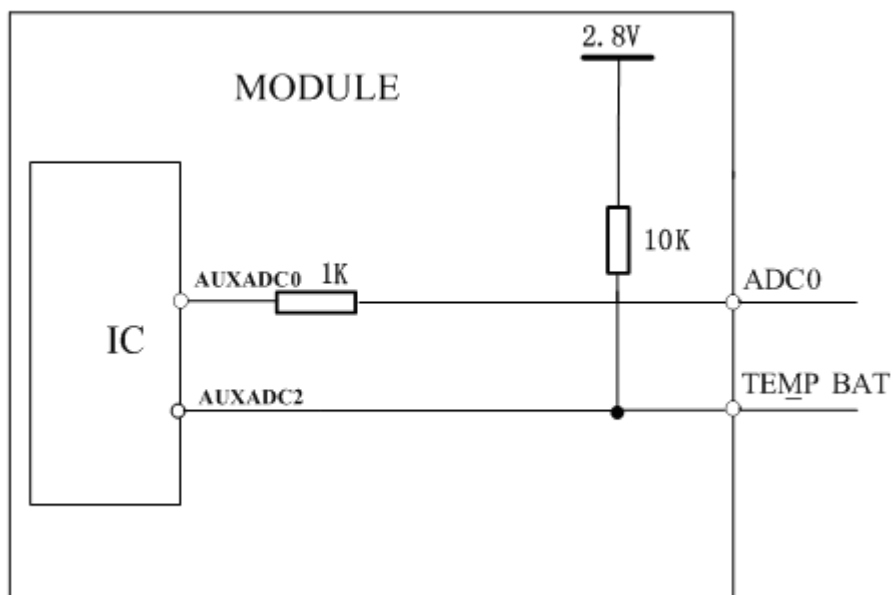

Figure 29: Internal circuit of the ADC

Table 22: Characteristics of the ADC

	Min	Typ	Max	Units
Voltage range	0		2.8	V
ADC Resolution	10		10	bits
ADC accuracy		2.7		mV

4.15. Behaviors of the RI

Table 23: Behaviours of the RI

State	RI respond
Standby	HIGH
Voice calling	Change LOW, then: <ol style="list-style-type: none"> (1) Change to HIGH when establish calling. (2) Use AT command ATH, the RI pin changes to HIGH. (3) Sender hangs up, change to HIGH. (4) Change to HIGH when SMS received.
Data calling	Change LOW, then: <ol style="list-style-type: none"> (1) Change to HIGH when establish calling. (2) Use AT command ATH, the RI changes to HIGH.

SMS	When receive SMS, The RI will change to LOW and hold low level about 120 ms, then change to HIGH.
URC	Some URCs triggers 120ms low level on RI. For more details, please refer to the <i>document [10]</i>

If the module is used as caller, the RI will maintain high. However, when it is used as receiver, following is timing of ring.

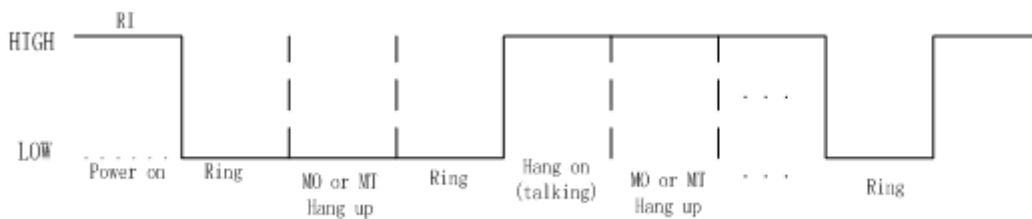

Figure 30: Module Services as Receiver

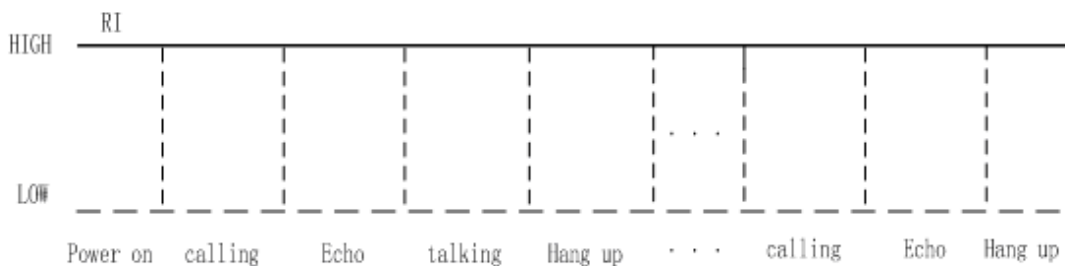

Figure 31 : Module Services as caller

4.16. Network status indication

The NETLIGHT signal can be used to drive a network status indication LED lamp. The working state of this pin is listed in following table:

Table 24: Working state of the NETLIGHT

State	Module function
Off	The module is not running
64ms On/ 800ms Off	The module does not find the network
64ms On/ 3000ms Off	The module find the network
64ms On/ 300ms Off	GPRS communication

We provide a reference circuitry for you, shown as following figure:

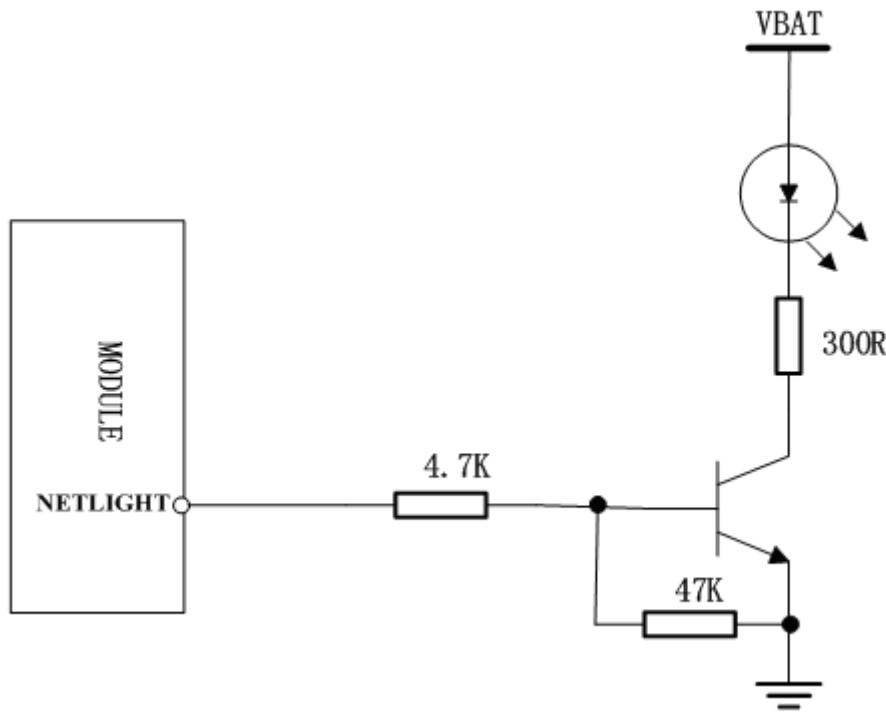

Figure 32: Reference circuit of the NETLIGHT

4.17. General purpose input & output (GPIO)

The module provides a limited number of General Purpose Input/Output signal pin.

Table 25: Pin define of the GPIO interface

Name	Pin	Function
GPIO0	9	General Purpose Input/Output Port
GPIO1	40	General Purpose Input/Output Port Keypad interface KBR5

Note: This function is not supported in the default firmware. There must be special firmware if you require. Please contact TECHWISH for more details .

4.18. Open drain output (LIGHT_MOS)

The module provides a open drain output pin to control LCD or keyboard backlight. The output LIGHT_MOS can sink150mA. And all the open-drain output switches are high impedance when disabled.

Table 26: Pin define of the LIGHT_MOS

Name	Pin	Function
LIGHT_MOS	32	Open Drain Output Port

Note: This function is not supported in the default firmware. There must be special firmware if you require. Please contact TECHWISH for more details .

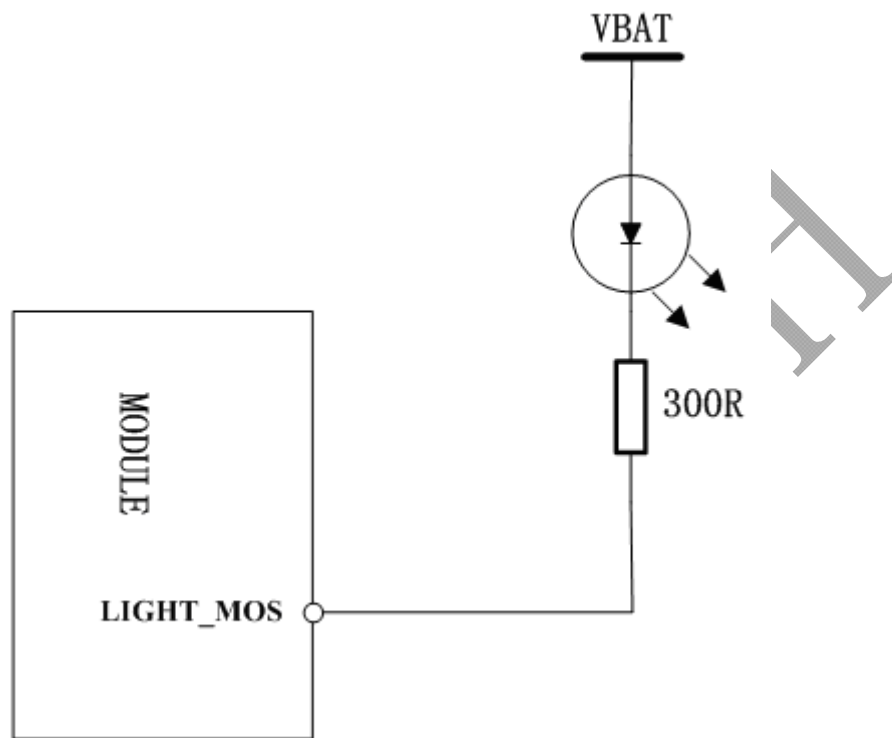

Figure 33: Reference circuit of the LIGHT_MOS

5. Antenna interface

The Pin 45 is the RF antenna pad. The RF interface has an impedance of 50Ω.

5.1. Antenna installation

TG105 provides a RF antenna PAD for customer's antenna installation. The customer's antenna should be located in the customer's mainboard and connect to module's antenna pad through microstrip line or other type RF trace which the impedance must be controlled in 50Ω. To help the customer to ground the antenna, TG105 comes with a grounding plane located close to the antenna pad. The antenna pad of TG105 is shown as follow.

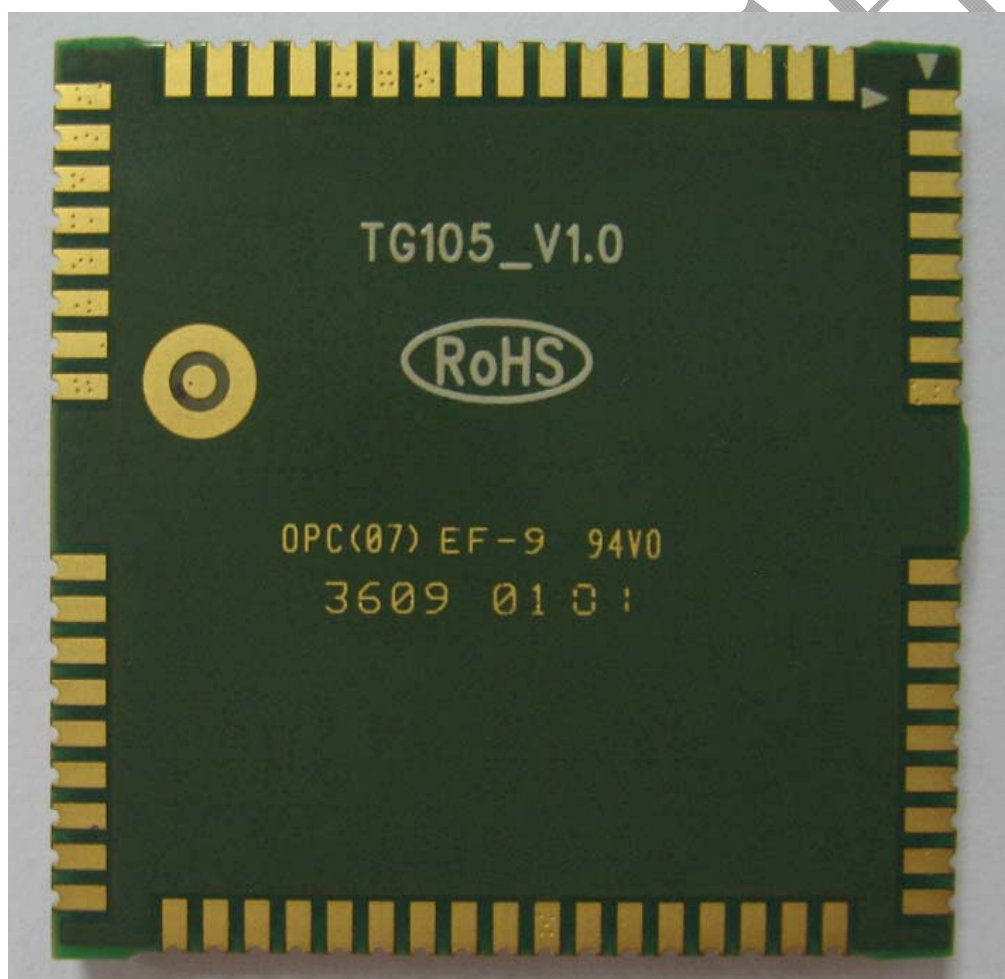

Figure 34: The RF interface of module

If the customer install the antenna via a soldered microwave coaxial cable, to minimize the loss on the RF cable, we suggest the customer to choose RF cable carefully. And the recommended insertion loss should be less than the following requirements:

- GSM850/EGSM900<0.5dB

- DCS1800/PCS1900<1dB

5.2. RF output power

Table 27: The module conducted RF output power

Frequency	Max	Min
GSM850	33dBm ±2db	5dBm±5db
EGSM900	33dBm ±2db	5dBm±5db
DCS1800	30dBm ±2db	0dBm±5db
PCS1900	30dBm ±2db	0dBm±5db

5.3. RF receive sensitivity

Table 28: The module conducted RF receive sensitivity

Frequency	Receive sensitivity
GSM850	< -106dBm
EGSM900	< -106dBm
DCS1800	< -106dBm
PCS1900	< -106dBm

5.4. Operating frequencies

Table 29: The module operating frequencies

Frequency	Receive	Transmitting	channel
GSM850	869 ~ 894MHz	824 ~ 849MHz	128 ~ 251
EGSM900	925 ~ 960MHz	880 ~ 915MHz	0~124, 975~1023
DCS1800	1805 ~ 1880MHz	1710 ~ 1785MHz	512 ~ 885
PCS1900	1930 ~ 1990MHz	1850 ~ 1910MHz	512 ~ 810

6. Electrical, reliability and radio characteristics

6.1. Absolute maximum ratings

Absolute maximum rating for power supply and voltage on digital and analog pins of module are listed in following table:

Table 30: Absolute maximum ratings

Parameter	Min	Max	Unit
VBAT	0	4.7	V
Peak current of power supply	0	3.0	A
RMS current of power supply (during one TDMA- frame)	0	0.7	A
Voltage at digit pins	-0.3	3.3	V
Voltage at analog pins	-0.3	3.0	V
Voltage at digit/analog pins in POWER DOWN mode	-0.25	0.25	V

6.2. Operating temperatures

The operating temperature is listed in following table:

Table 31: Operating temperature

Parameter	Min	Typ	Max	Unit
Ambient temperature	-20	25	60	°C
Restricted operation*	-30 to -20		60 to 80	°C
Storage temperature	-40		+85	°C

* If the module does work in this temperature range, the deviations from the GSM specification may occur. For example, the frequency error or the phase error will increase.

6.3. Power supply ratings

Table 32: The module power supply ratings

Parameter	Description	Conditions	Min	Typ	Max	Unit	
VBAT	Supply voltage	Voltage must stay within the min/max values, including voltage drop, ripple, and spikes.	3.4	4.0	4.5	V	
	Voltage drop during transmitting burst	Normal condition, power control level for Pout max			400	mV	
	Voltage ripple	Normal condition, power control level for Pout max @ f<200kHz @ f>200kHz			50 2	mV	
I _{VBAT}	Average supply current	POWER DOWN mode		65		uA	
		SLEEP mode		1.5		mA	
		Minimum functionality mode					
		AT+CFUN=0		12		mA	
		IDLE mode		900		uA	
		SLEEP mode					
		AT+CFUN=4		12		mA	
		IDLE mode		1		mA	
SLEEP mode							
IDLE mode							
GSM850/EGSM 900		13					
DCS1800/PCS1900		13			mA		
TALK mode							
GSM850/EGSM 900 ¹⁾		290/260			mA		
DCS1800/PCS1900 ²⁾		250/245					
DATA mode, GPRS (3 Rx,2Tx)							
GSM850/EGSM 900 ¹⁾		480/460			mA		
DCS1800/PCS1900 ²⁾		360/395					
DATA mode, GPRS (4 Rx,1Tx)							
GSM850/EGSM 900 ¹⁾		300/290			mA		
DCS1800/PCS1900 ²⁾		250/240					

	Peak supply current (during transmission slot every 4.6ms)	Power control level for Pout max.		2	3	A
--	--	-----------------------------------	--	---	---	---

¹⁾ Power control level PCL 5

²⁾ Power control level PCL 0

6.4. Current consumption

The values for current consumption show as following table.

Table 33: The module current consumption

Voice Call	
GSM850	@power level #5 <300mA, Typical 270mA @power level #10, Typical 150mA @power level #19, Typical 100mA
EGSM 900	@power level #5 <300mA, Typical 270mA @power level #10, Typical 140mA @power level #19, Typical 100mA
DCS 1800	@power level #0 <250mA, Typical 240mA @power level #10, Typical 150mA @power level #15, Typical 100mA
PCS 1900	@power level #0 <250mA, Typical 250mA @power level #10, Typical 150mA @power level #15, Typical 100mA
GPRS Data	
DATA mode, GPRS (1 Rx, 1 Tx) CLASS 12	
GSM850	@power level #5 <350mA, Typical 280mA @power level #10, Typical 145mA @power level #19, Typical 90mA
EGSM 900	@power level #5 <350mA, Typical 260mA @power level #10, Typical 135mA @power level #19, Typical 90mA
DCS 1800	@power level #0 <300mA, Typical 200mA @power level #10, Typical 120mA @power level #15, Typical 90mA
PCS 1900	@power level #0 <300mA, Typical 230mA @power level #10, Typical 130mA @power level #15, Typical 90mA
DATA mode, GPRS (3 Rx, 2 Tx) CLASS 12	

GSM850	@power level #5 <550mA,Typical 530mA @power level #10,Typical 265mA @power level #19,Typical 145mA
EGSM 900	@power level #5 <550mA,Typical 485mA @power level #10,Typical 250mA @power level #19,Typical 145mA
DCS 1800	@power level #0 <450mA,Typical 370mA @power level #10,Typical 165mA @power level #15,Typical 135mA
PCS 1900	@power level #0 <450mA,Typical 390mA @power level #10,Typical 220mA @power level #15,Typical 128mA
DATA mode, GPRS (4 Rx,1 Tx) CLASS 12	
GSM850	@power level #5 <350mA,Typical 320mA @power level #10,Typical 182mA @power level #19,Typical 125mA
EGSM 900	@power level #5 <350mA,Typical 300mA @power level #10,Typical 175mA @power level #19,Typical 125mA
DCS 1800	@power level #0 <300mA,Typical 240mA @power level #10,Typical 135mA @power level #15,Typical 120mA
PCS 1900	@power level #0 <300mA,Typical 230mA @power level #10,Typical 128mA @power level #15,Typical 115mA
DATA mode, GPRS (1 Rx, 4 Tx) CLASS 12	
GSM850	@power level #5 <660mA,Typical 610mA @power level #10,Typical 390mA @power level #19,Typical 200mA
EGSM 900	@power level #5 <660mA,Typical 610mA @power level #10,Typical 380mA @power level #19,Typical 200mA
DCS 1800	@power level #0 <530mA,Typical 500mA @power level #10,Typical 350mA @power level #15,Typical 200mA
PCS 1900	@power level #0 <530mA,Typical 525mA @power level #10,Typical 380mA @power level #15,Typical 210mA

Class 12 is default set when the module works at data translation mode, the module can also work at class 10 and class 8 set by AT command.

6.5. Electro-static discharge

The GSM engine is not protected against Electrostatic Discharge (ESD) in general. Therefore, it is subject to ESD handling precautions that typically apply to ESD sensitive components. Proper ESD handling and packaging procedures must be applied throughout the processing, handling and operation of any application using a module.

The measured values of module are shown as the following table:

Table 34: The ESD endure statue measured table (Temperature: 25°C, Humidity: 45 %)

Part	Contact discharge	Air discharge
VBAT,GND	±4KV	±8KV
PWRKEY	±2KV	±4KV
Antenna port	±4KV	±8KV
SPK1P/1N, SPK2P/2N, MIC1P/1N, MIC2P/2N,	±2KV	±4KV

7. Product information

Table 35: Ordering information

Part Number	TG105
Frequency Bands(MHz)	EGSM900 DCS1800
RF Function	GSM/GPRS
Pin Compatible	YES

8. Mechanics

This chapter describes the mechanical dimensions of the module.

8.1. Mechanical dimensions of module and module PCB decal

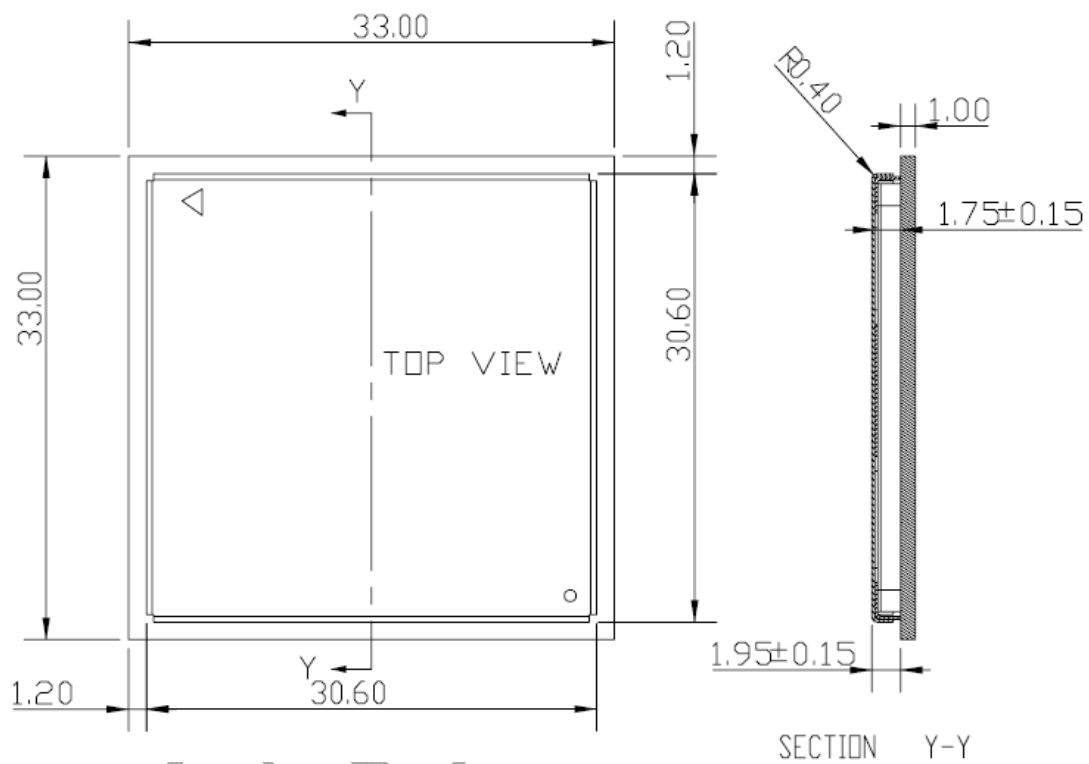

Figure 35: TG105 TOP view and SIDE view (Unit: mm)

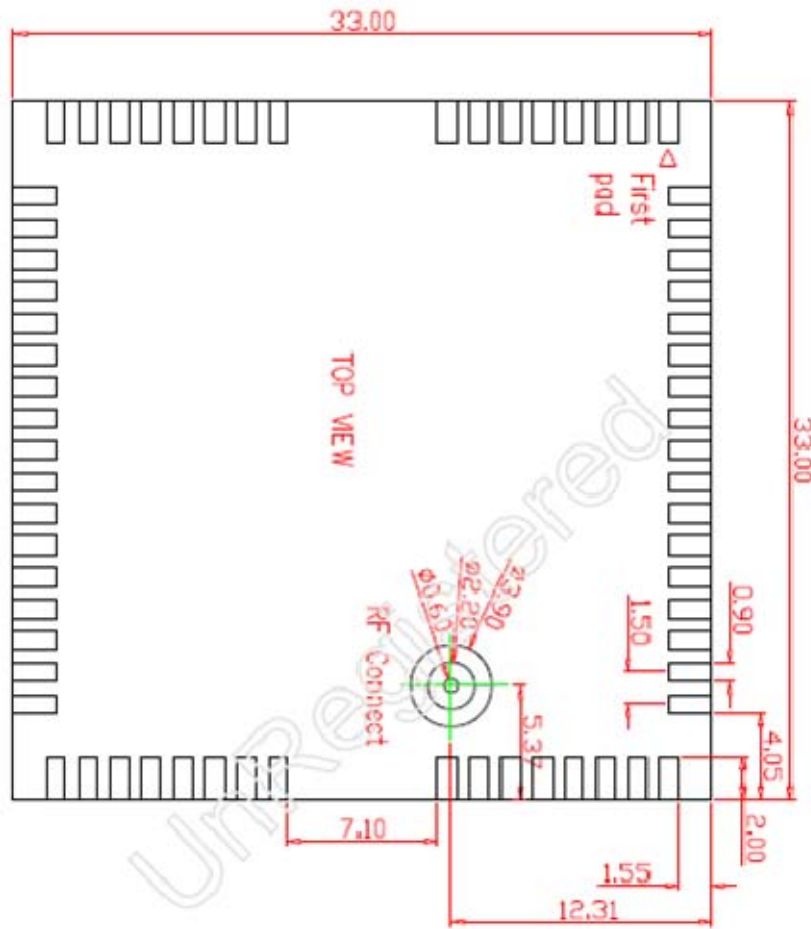

Figure 36: TG105 bottom view (Unit: mm)

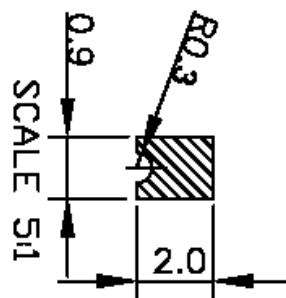

Figure 37: PAD BOTTOM VIEW (Unit: mm)

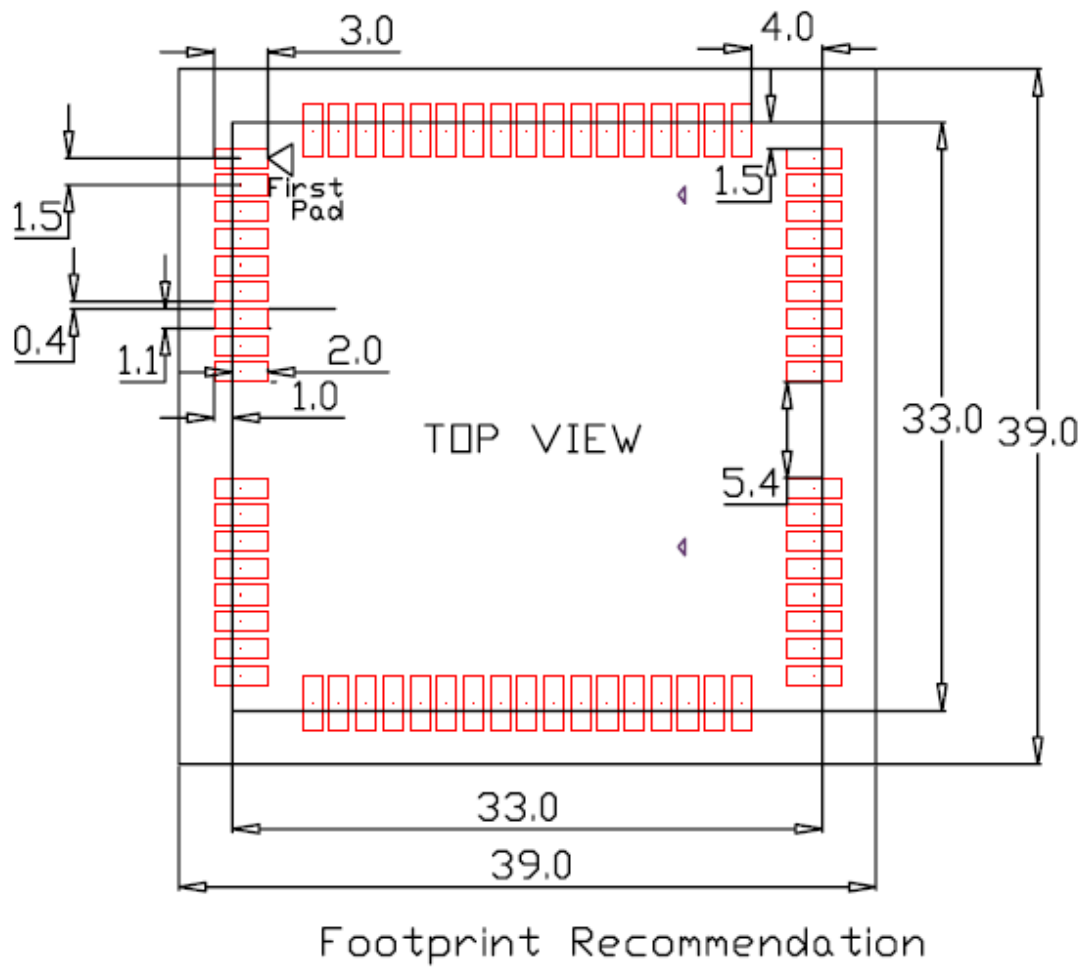

Figure 38: Footprint of recommendation (Unit: mm)

Note1: Keep out on the user mainboard below the test point and the keep out area ,as these are solder mask.

Note2: For maintain this module, the placement must be keep a distance between the module and other component about 3 mm, and the height of near components must less than 16mm.

8.2. Top view of the module

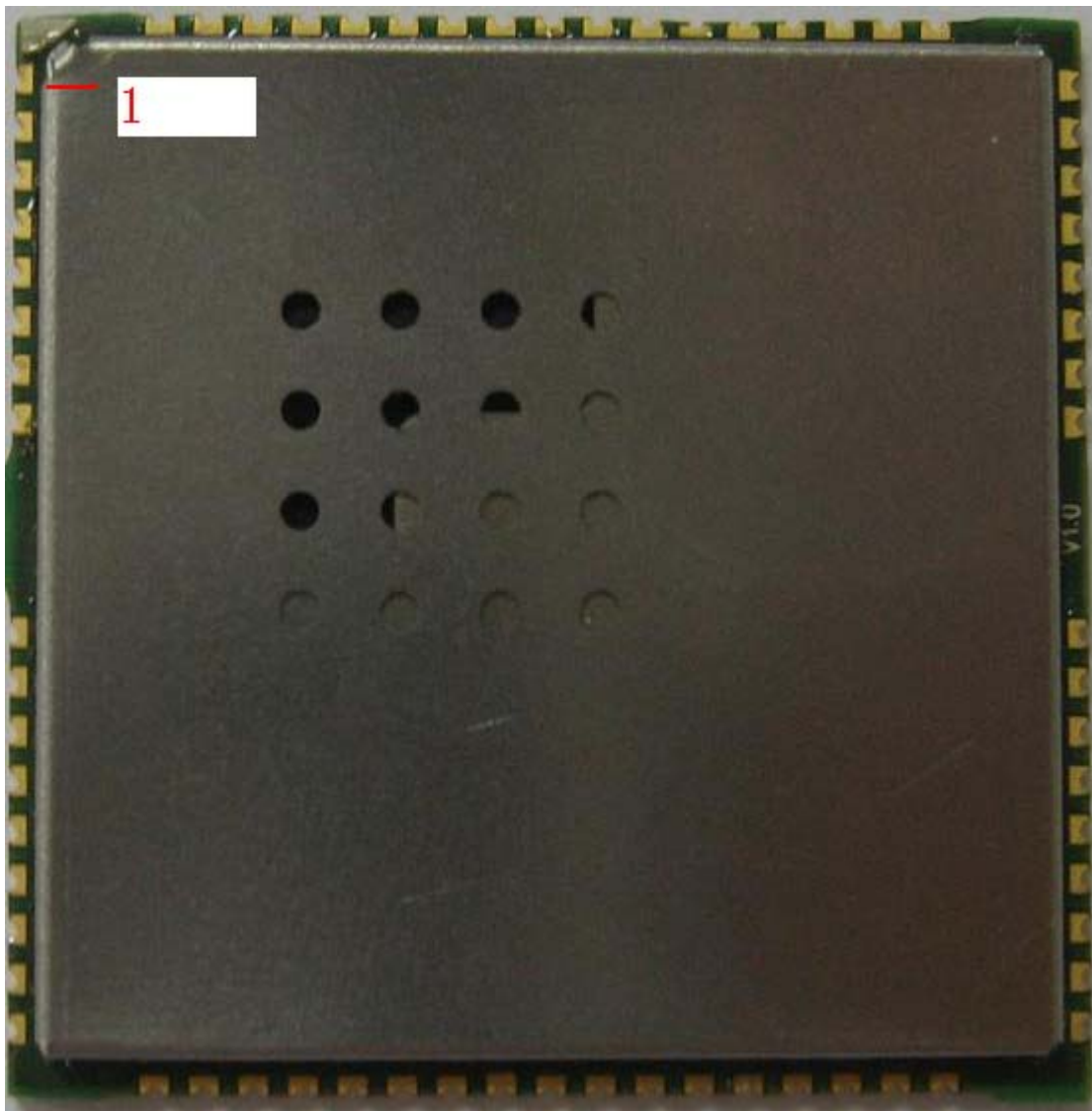

Figure 39: Top view of the module

8.3. PIN assignment of SMT pads of the module

Notes 1: Be careful, the connection diagrams adapt to only right module, please check your module type.

Note2: please keep all reserved pins open.

Table 36: TG105 Connection diagrams

PIN NO.	PIN NAME	I/O		PIN NO.	PIN NAME	I/O
1	NETLIGHT	O		2	VDD_EXT	O
3	DISP_RST	O		4	DISP_D/C	O
5	DISP_CS	O		6	DISP_CLK	O
7	DISP_DATA	I/O		8	GND1	
9	GPIO0	I/O		10	SIM_DATA	I/O
11	SIM_CLK	O		12	SIM_RST	O
13	SIM_VDD	O		14	Reserved	
15	Reserved			16	SPK2N	O
17	SPK2P	O		18	MIC1P	I
19	MIC1N	I		20	SPK1N	O
21	SPK1P	O		22	MIC2P	I
23	MIC2N	I		24	AGND	
25	GND2			26	LIGHT_MOS	O
27	VRTC	I/O		28	SIM_PRESENCE	I
29	PWRKEY	I		30	KBR0	I
31	KBR1	I		32	KBR2	I
33	KBR3	I		34	KBR4	I
35	KBC0	O		36	KBC1	O
37	KBC2	O		38	KBC3	O
39	KBC4	O		40	GPIO1	I/O
41	DBG_TXD	O		42	DBG_RXD	I
43	TEMP_BAT	I		44	GND3	
45	RF_IN	I/O		46	GND4	
47	GND5			48	GND6	
49	GND7			50	GND8	
51	GND9			52	ADC0	I
53	VBAT1	I		54	VBAT2	I
55	VBAT3	I		56	GND10	
57	GND11			58	GND12	
59	Reserved			60	BUZZER	O
61	RI	O		62	RTS	I
63	CTS	O		64	Reserved	
65	RXD	I		66	TXD	O
67	DTR	I		68	DCD	O

9. Contact us

Shanghai Techwish Information Technology Co. Ltd

Add: Room 512, Xingyuan Building, No. 418, Guiping Road

Tel: +86 21 6485 2266

Fax: +86 21 6485 2266*602

URL: www.techwish.com.cn

TECHWISH