

LA, RA, LL, V1, V2, V3, V4, V5, V6, 1mv  
 LA, RA, LA+LL, RA+LA, RA+LL, RA+LA+LL, AGND

- LEAD I : LA - RA
- LEAD II : LL - RA
- LEAD III : LL - LA
- AVR : RA - (LA+LL)
- AVL : LA - (RA+LL)
- AVF : LL - (RA+LA)
- V1 : V1 - (RA+LA+LL)
- V2 : V2 - (RA+LA+LL)
- V3 : V3 - (RA+LA+LL)
- V4 : V4 - (RA+LA+LL)
- V5 : V5 - (RA+LA+LL)
- V6 : V6 - (RA+LA+LL)
- 1mv : 1mv - AGND

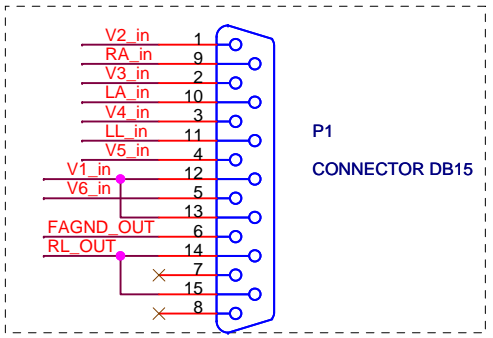

PB2 pin37 BOOT1=0  
 pin94 BOOT0=0  
 PB4 NJTRST

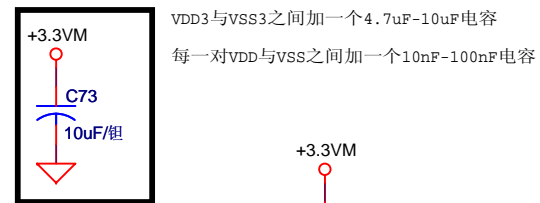
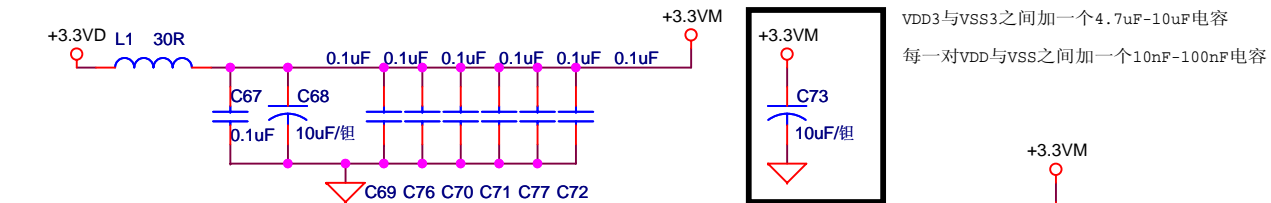
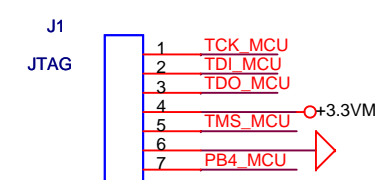

VDD3与VSS3之间加一个4.7uF-10uF电容  
 每一对VDD与VSS之间加一个10nF-100nF电容

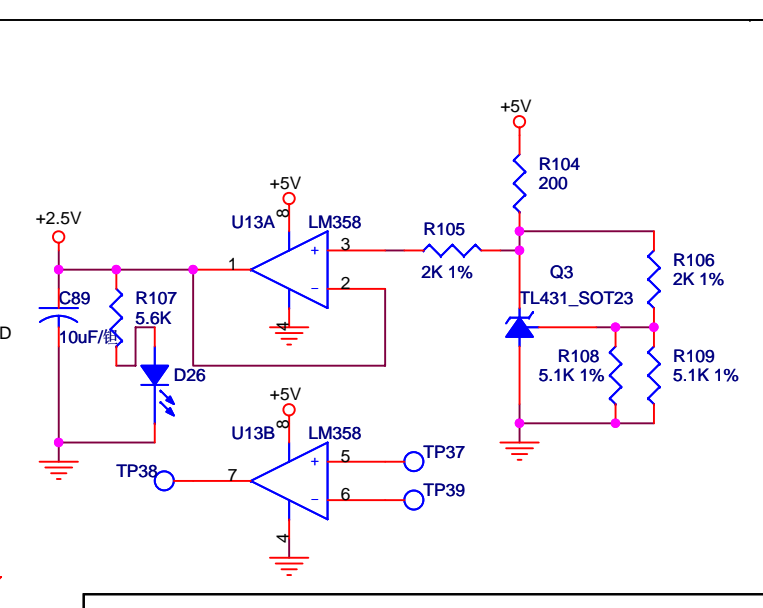
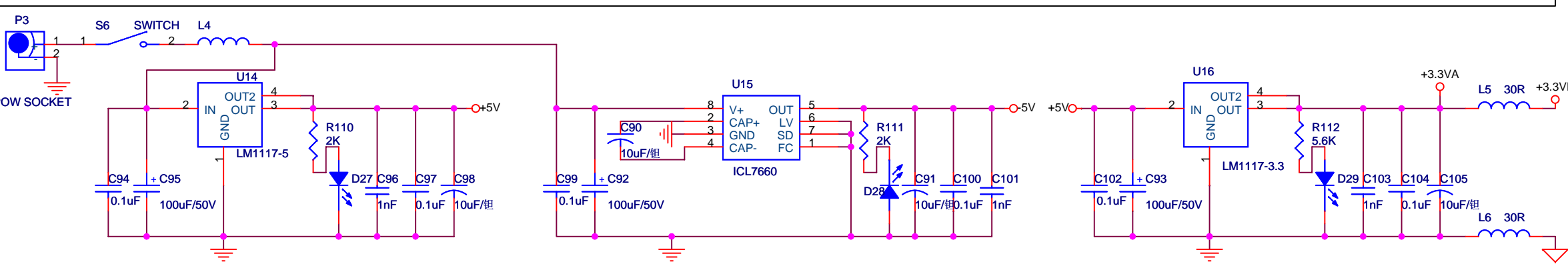
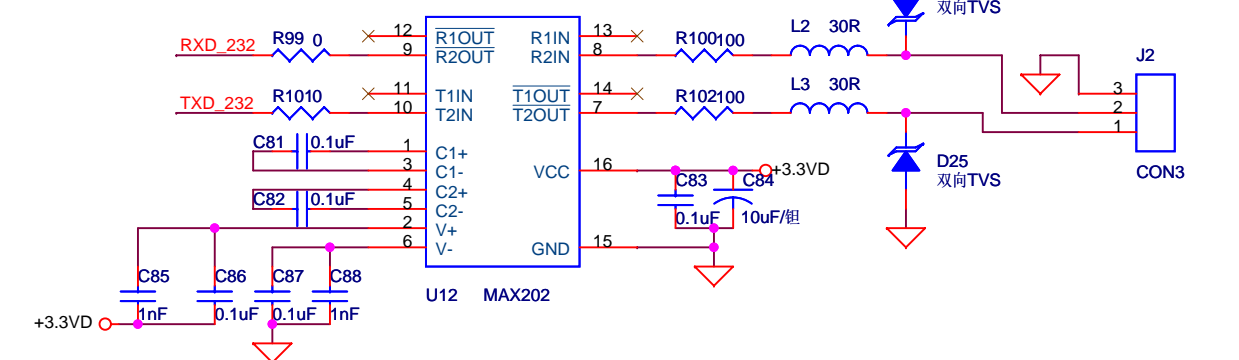
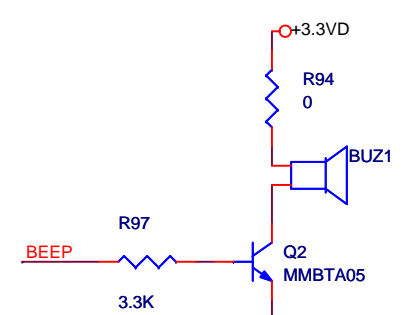
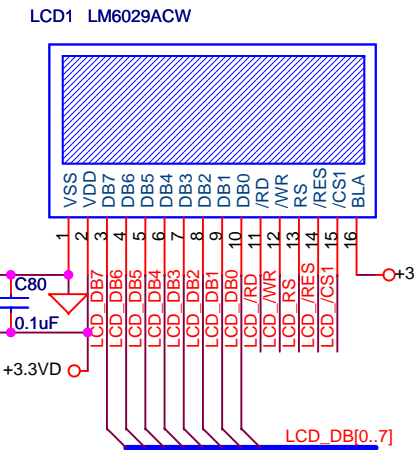
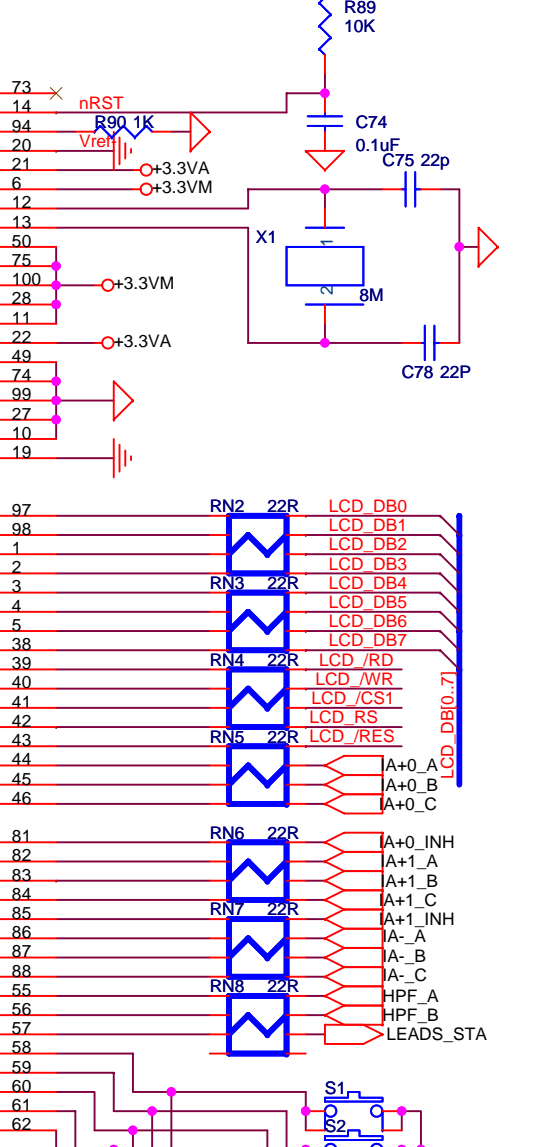
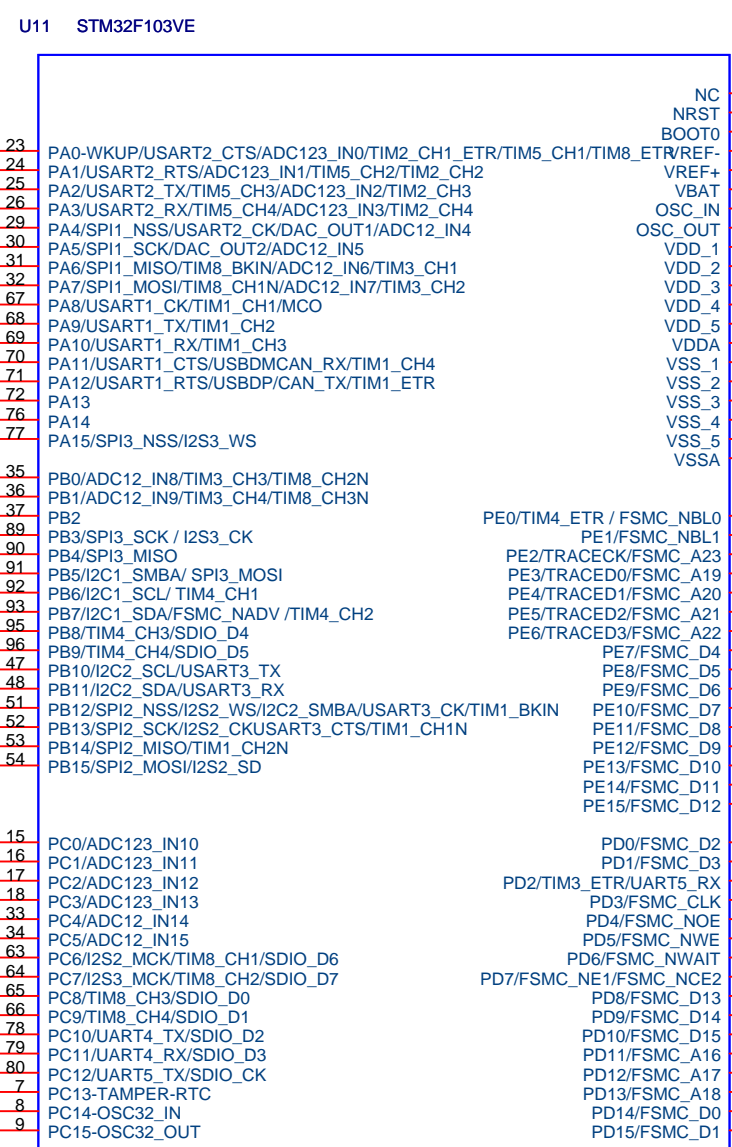

Title		<Title>
Size		A3
Document Number		<Doc>
Date:		Tuesday, August 24, 2010
Sheet		2 of 2
Rev		<RevC>

**YEMI\_ECG\_12LEADS**