

DATE	REV	REVISION HISTORY
11/24/09	2	CORRECTED D2 FOOTPRINT REMOVE GPIO99 FROM ADC5 (TS) CHANGE VCORE TO 1.35V/0.9V INCREASED MEMORY SIZES
12/11/09	3	ADD SUPPORT USB OTG ADD SUPPORT FOR TRI-STATE OF Y3 FOR LOW POWER

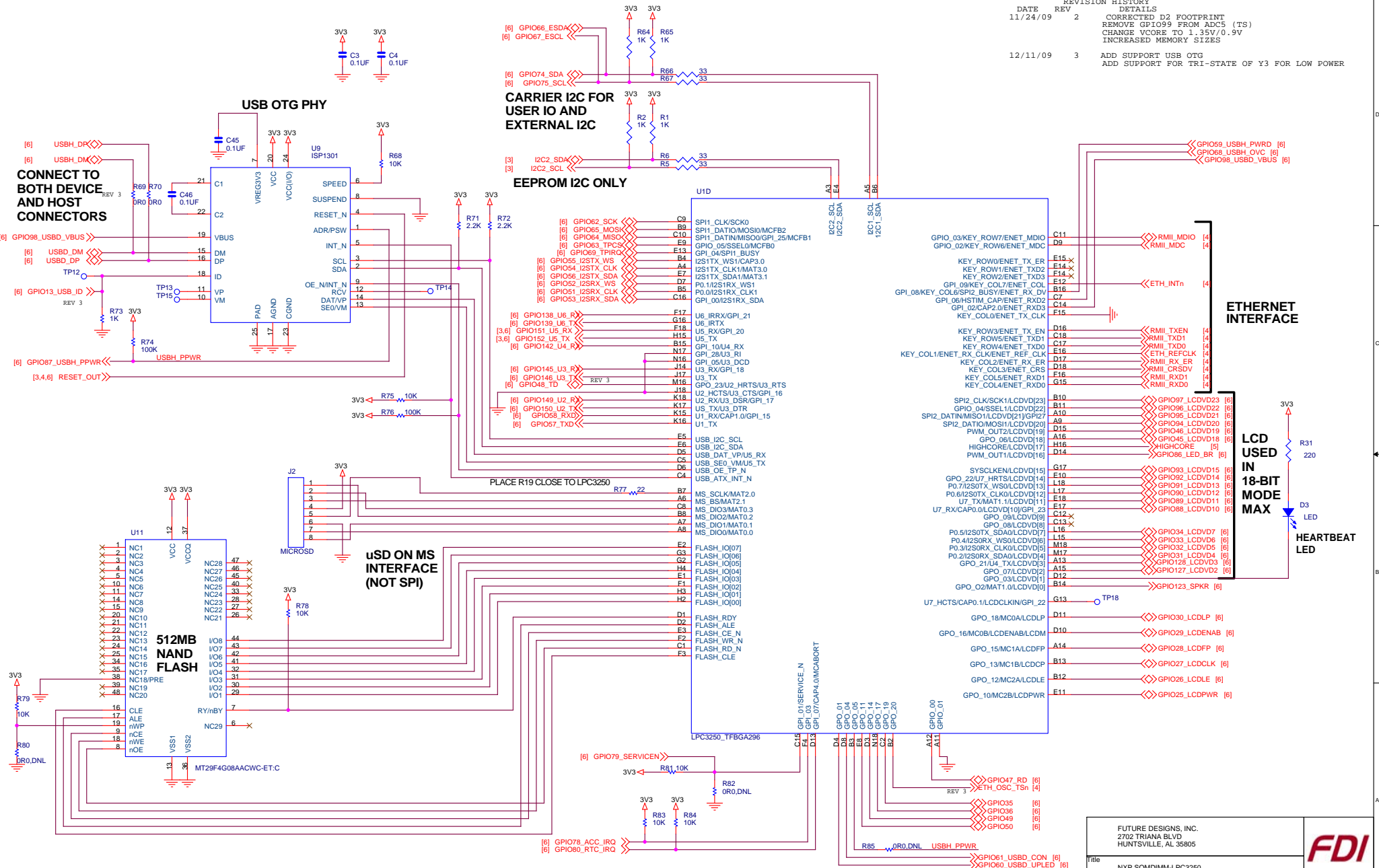

SERVICE_N = 0 , LOAD FROM UART5/USB
 SERVICE_N = 1 , LOAD FROM, THEN FOLLOW SEQUENCE;
 SPI > EMC CS0 > NAND

FUTURE DESIGNS, INC. 2702 TRIANA BLVD HUNTSVILLE, AL 35805		
File	NXP SOMDMM-LPC3250	
Size	Document Number	Rev 3
Date:	Friday, December 11, 2009	Sheet 1 of 6

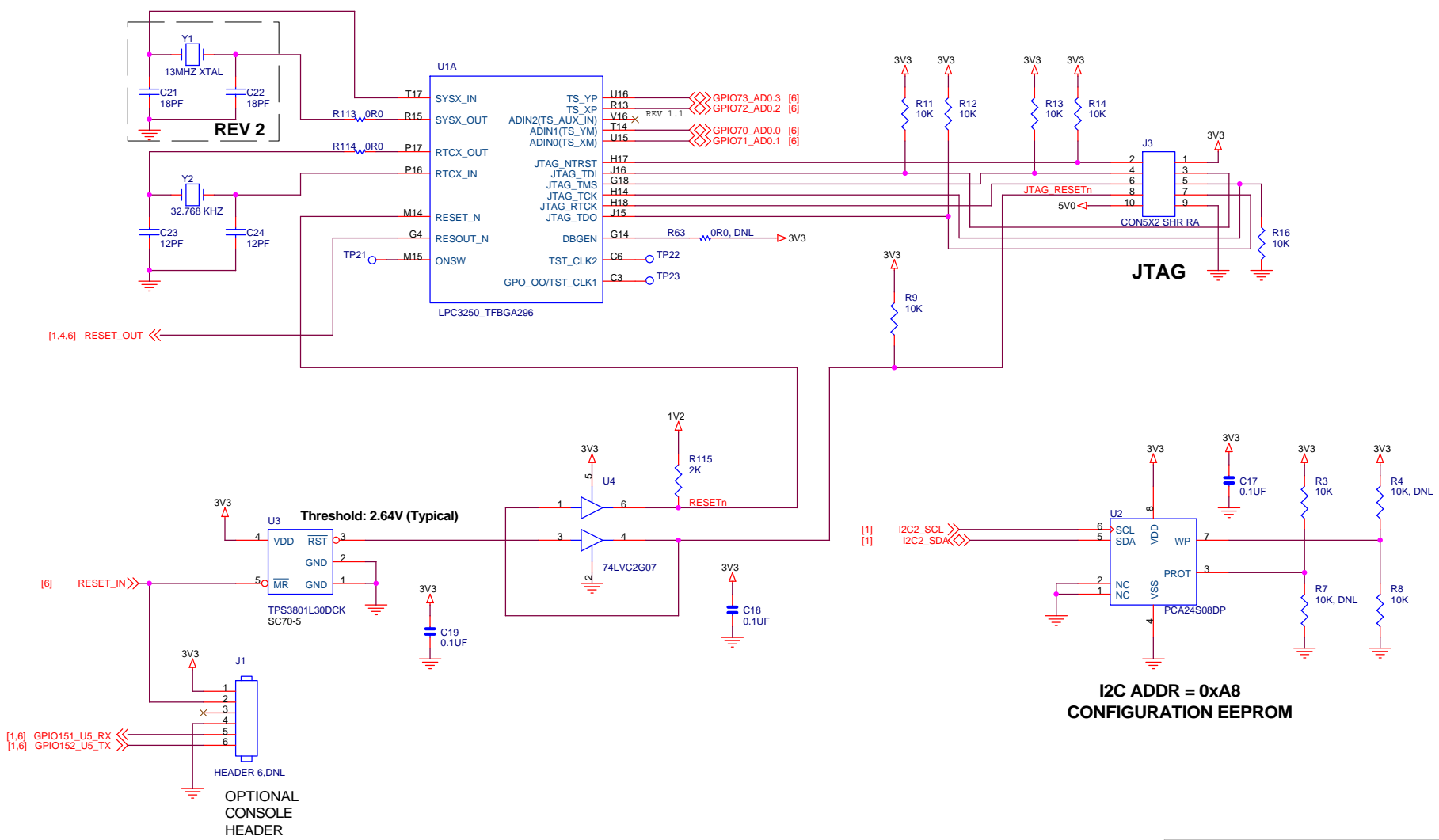

FUTURE DESIGNS, INC. 2702 TRIANA BLVD HUNTSVILLE, AL 35805		FDI
Title NXP SOMDIMM-LPC3250		
Size B	Document Number <Doc>	Rev 3
Date: Friday, December 11, 2009	Sheet 3	of 6

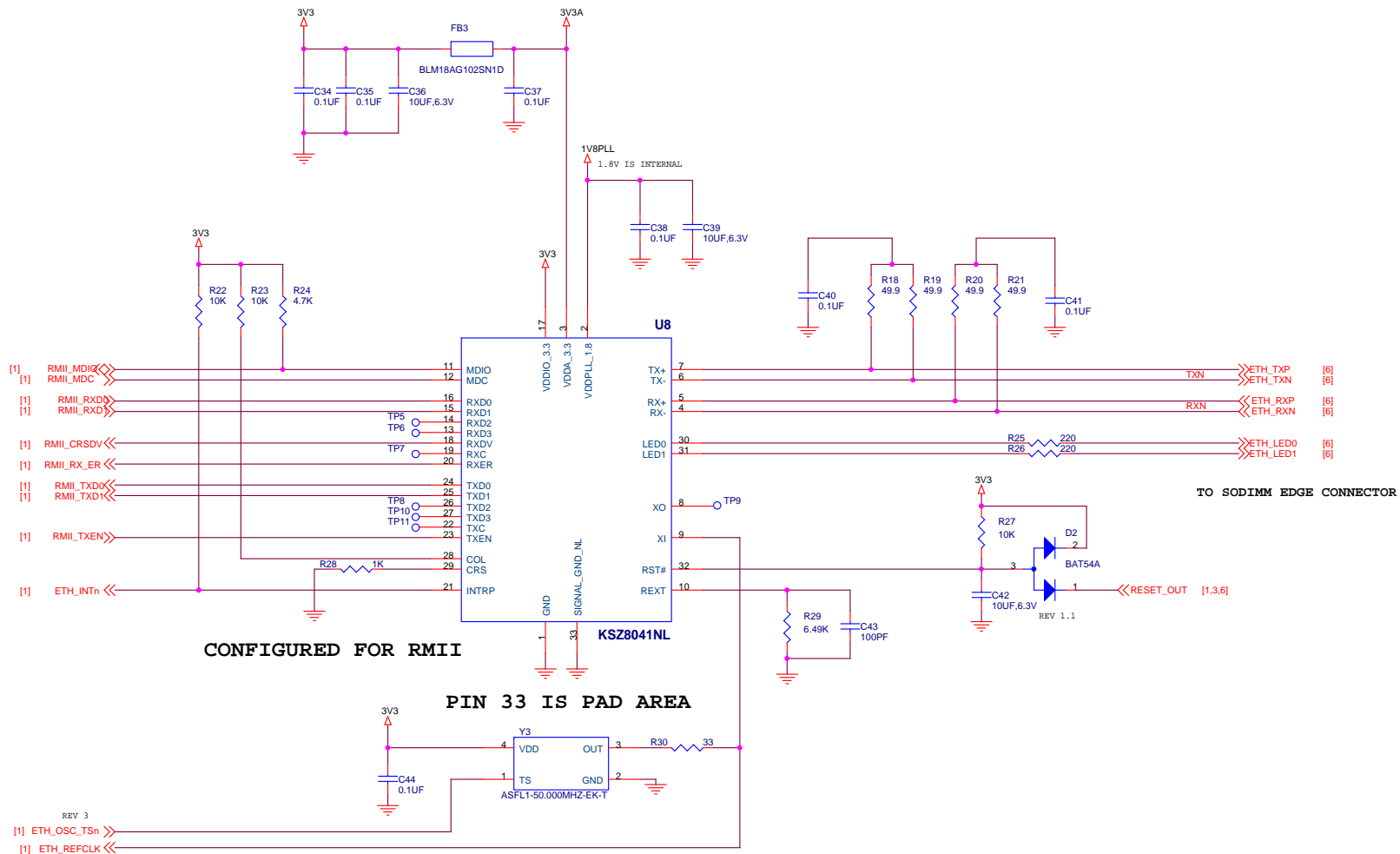

FUTURE DESIGNS, INC. 2702 TRIANA BLVD HUNTSVILLE, AL 35805		FDI
Title	NXP SOMDIMM-LPC3250	
Size	Document Number	Rev 3
Date:	Friday, December 11, 2009	Sheet 4 of 6

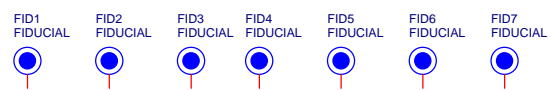
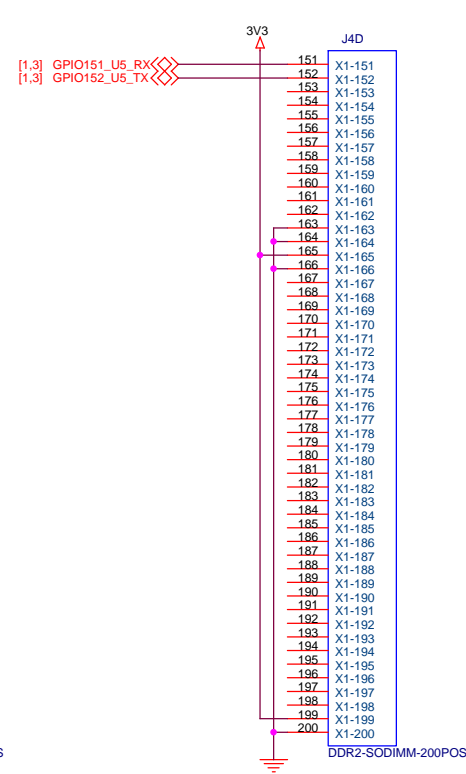
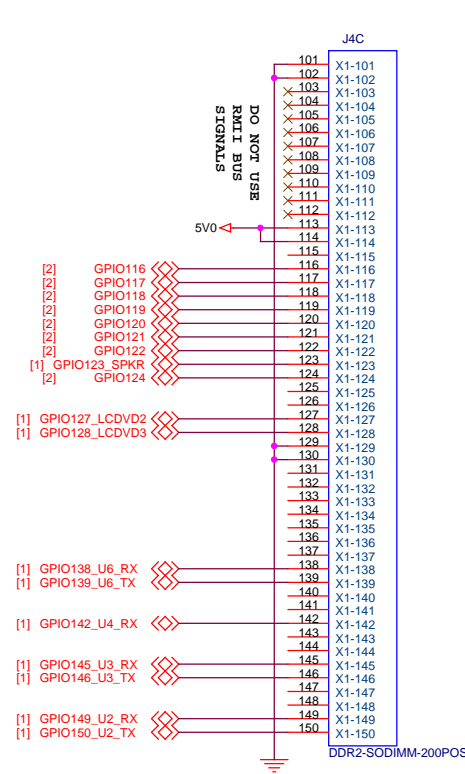
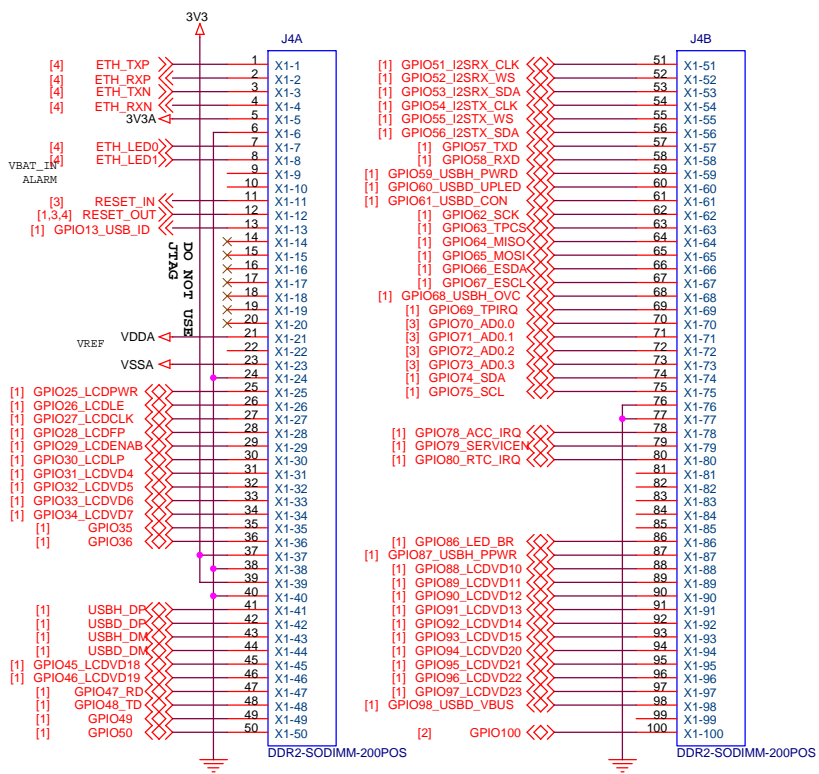

FUTURE DESIGNS, INC. 2702 TRIANA BLVD HUNTSVILLE, AL 35805		
Title NXP SOMDIMM-LPC3250		
Size B	Document Number <Doc>	Rev 3
Date: Friday, December 11, 2009	Sheet 6	of 6