

6

5

4

3

2

1

D

C

B

A

REVISION RECORD			
LTR	ECO NO:	APPROVED:	DATE:

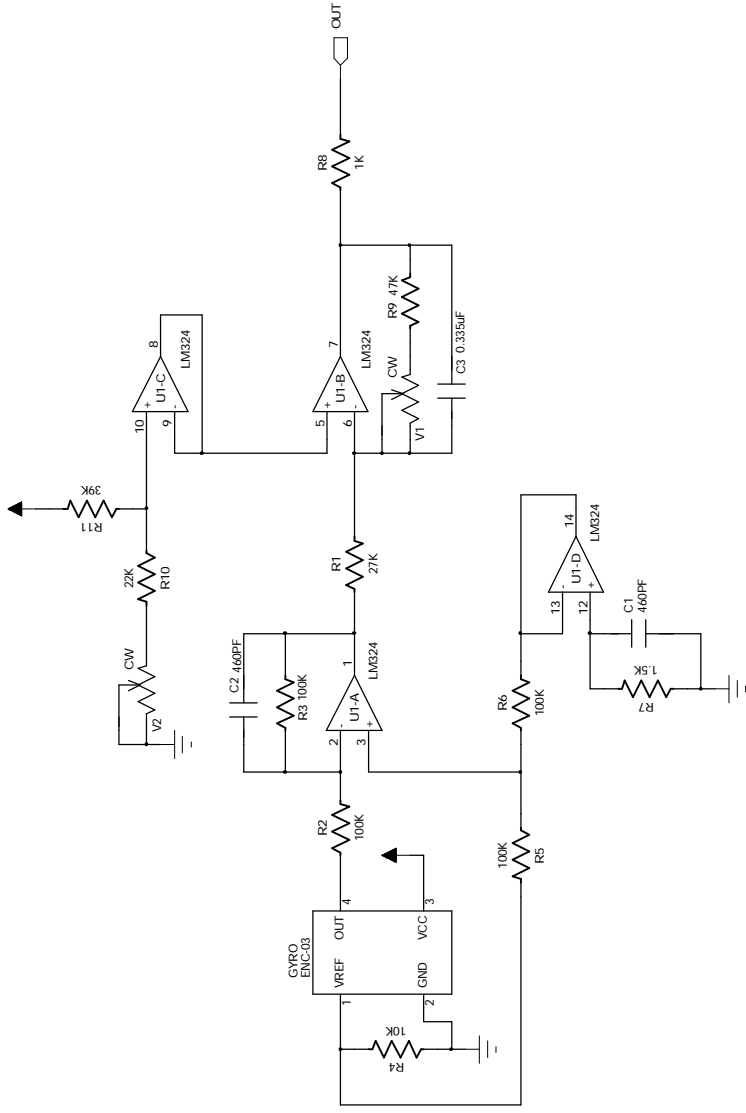

COMPANY:			
TITLE:			
DRAWN:	DATED:	CODE:	SIZE: A3
CHECKED:	DATED:	DRAWING NO:	REV:
QUALITY CONTROL:	DATED:		
RELEASED:	DATED:	SCALE: ϕ	SHEET: 1