



MSP430 and nRF24L01 based Wireless Sensor Network Design with Adaptive Power Control

S. S. Sonavane¹, V. Kumar¹, B. P. Patil²

¹Department of Electronics & Instrumentation Indian School of Mines University, Dhanbad-826004, India

ssonavane@gmail.com, vkumar52@hotmail.com

² Department of Electronics Engineering Maharashtra Academy of Engineering, Alandi (Pune)
bpatil@maepune.com

Abstract

In this paper, we have developed a Low cost and low power Wireless Sensor Networks (WSNs) Node using MSP430 and Nordic nRF24L01. The architectural and circuit details are presented. This architecture fulfils the requirements of low power, compact size and self-organization with a new feature of adaptive Power Control. For Low power consumption Adaptive Power control technique is used. In this technique we can vary the transmitted power according to the distance between the nodes, which is also the different feature of this WSN. Adaptive power algorithm that uses both RF output Power and Transmission rate to be adjusted according to the distance between the Nodes which will maximize the battery life time. All the Radio modules available in the market are utilizing constant power transmission during its operation. Hence significant reduction in energy consumption is possible based on the proposed approach which prolongs the battery lifetime.

Keywords: *Wireless Sensor Networks (WSNs), MSP430, Nordic nRF24L01, Adaptive power algorithm.*

1. Introduction

A wireless sensor network is a network made up of hundreds or thousands of Sensor nodes, which are densely deployed in an unattended environment. These nodes are capable of communicating by means of wireless communications, sensing and self-computation (software, hardware, algorithms) [1]. Hence the wireless sensor network is the result of the combination of sensor, embedded techniques, distributed information processing, and communication mechanisms. The sensor network is more application specific than traditional networks designed to accommodate various applications. The

organization and architecture of a sensor network should be designed or adapted to suit a special task so as to optimize the system performance, maximize the operation lifetime and minimize the cost. Thus, in order to maximize the sensor network lifetime, the sensor network architecture will most likely tip toward a localized approach.

We describe the design and implementation of a sensor node that utilizes emerging hardware, low cost components and new techniques to achieve high data rate, extremely low power operation. Low power operation is achieved not only through selection of efficient hardware, but also through low duty cycling and by Adaptive power algorithm implementation. One cycle of sleep, wakeup, and run is typically the cost of acquiring a single set of sensor samples. For the majority of the time the node is sleeping. While asleep, the microcontroller must maintain its state, while consuming little power and shutting down or disconnecting all peripherals including the radio. [2] For our WSN node design, we chose the Texas Instruments MSP430 microcontroller. The MSP430 consumes only 2 microwatts in sleep mode while maintaining RAM. The collection of various features has been integrated to create the highest data rate, lowest power mote to date. The remainder of the paper is organized as follows: Section (2) focuses on hardware details of WSN Node. Section (3) emphasizes on Adaptive power algorithm using variable power and transmission rate. Section (4) discusses lifetime improvement using adaptive power algorithm. Section (5) concludes the paper.

2. Hardware details of WSN Node

The hardware consists of MSP430 connected with nRF24L01 as shown in Figure1.



2.1 MSP430F1612

The Texas Instruments MSP430 family of ultra low power microcontroller consists of several devices featuring different sets of peripherals targeted for various applications. The architecture, combined with five low power modes is optimized to achieve extended battery life in portable measurement applications. The device features a powerful 16-bit RISC CPU, 16-bit registers, and constant generators that attribute to maximum code efficiency [3].

2.2 NORDIC nRF24L01:

The nRF24L01 is a single chip radio transceiver for the global, license-free 2.4 GHz ISM band. The low cost nRF24L01 is designed to merge very high speed communications (up to 2Mbit/s) with extremely low power (the RX current is just 12.5mA) [4]. The transceiver consists of a fully integrated frequency synthesizer, a power amplifier, crystal oscillator, demodulator, modulator and Enhanced ShockBurst protocol engine. In addition, the nRF24L01 also offers an innovative on-chip hardware solution called ‘MultiCeiver’ that can support up to six simultaneously communicating wireless devices. This makes it ideal for building wireless Personal Area Networks in a wide range of applications. The PCB of this WSN node is circular, having two inches diameter.

Output power, frequency channels, and protocol set-up are easily programmable through an SPI-bus. Current consumption is very low, only 8.5mA at an output power of -6dBm and 12.5mA in RX mode. Built-in modes such as Power Down (400nA current) and Standby (32µA at 130µs wakeup), makes significant power savings easily realizable. The data rate can be chosen between 1 and 2Mbit/s. This allows for short time-on-air and therefore low power consumption [5].

3. Adaptive Power Control Algorithm

Power efficiency is very important in wireless sensor networks because the sensors typically run on batteries and long lifetime is highly desirable. The algorithm used here is to set the transmission strength of the route update message. By setting the transmission strength, nodes can store the RSS (Received Signal Strength) and with the known transmission setting, distance to the transmitter can be estimated the node. Based on the estimated distance the node will then adjust its transmission power. Variable Transmission Control sets the transmission power based specifically on the RSS. It has multiple limits with each being associated with a different transmission setting.

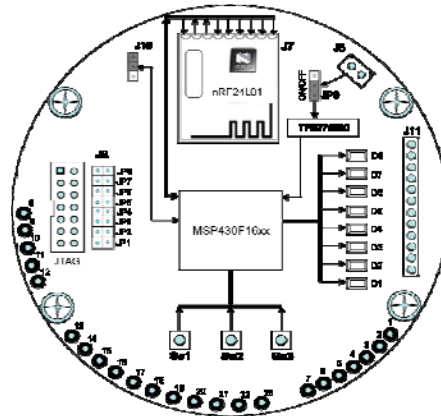

Figure 1 Front side of MSP430 and nRF24L01 based WSN node

The nRF24L01 uses a Received Signal Strength which outputs an analogue signal which is proportional to the input signal level on the RFI/O. This output current is converted into a voltage by a 50 ohm resistor which is in turn is read by the Analog to Digital Converter (ADC) channel 0 of the microcontroller.

Whichever way these nodes are deployed or powered, the limited supply of power of each node will always be an issue. The radio transmitters and receivers of the nodes are usually the main consumers of the power supply. The two biggest current consumers are when the node transmits at maximum power (11.3 mA) or when the node

The Table-1 shows the settings used to obtain Adaptive power control in WSNs, which decides the power, according to the distance between the nodes. This research gives an Adaptive power based WSN node rather than current techniques, which supports constant output power.

The PA control is used to set the output power from the nRF24L01 power amplifier (PA). In TX mode PA control has four programmable steps, see Table1. The PA control is set by the RF_PWR bits in the RF_SETUP register.

This algorithm is developed to minimize the power consumption of the WSN node by the use of variable power and variable transmission Rate. Previous method uses either Transmission Power or rate is to be varied according to the distance [6]. But we had developed a new algorithm with variable power and transmission rate both. The Received signal strength is considered to calculate the distance between the Nodes. The received signal strength is taken from RFI/O terminal of nRF24L01. This voltage is then fed to the internal ADC of MSP430.

SPI RF-SETUP (RF_PWR)	RF Output Power	DC Current Consumption
11	0 dBm	11.3 mA
10	-6 dBm	9.0 mA
01	-12 dBm	7.5 mA
00	-18 dBm	7.0 mA

Table-1 Output power control Settings at Nordic



The air data rate is the modulated signaling rate the nRF24L01 uses when transmitting and receiving data. The air data rate can be 1Mbps or 2Mbps. The 1Mbps data rate gives 3dB better receiver sensitivity compared to 2Mbps. High air data rate means lower average current consumption and reduced probability of on-air collisions. The air data rate is set by the RF_DR bit in the RF_SETUP register.

The Data Rate is kept at 2Mbps when the node is transmitting with higher power levels (i.e. at 0dBm and -6dBm) and 1 Mbps when transmitting at low power levels (i.e. at -12dBm and -18dBm) as given in Table-2.

Distance Between Nodes (Meter)	Output Power Setting at Transmitter	Transmission Rate (Mbps)
8 to 10	0 dBm	2
6 to 8	-6 dBm	2
3 to 6	-12 dBm	1
0 to 3	-18 dBm	1

Table-2 output Transmission Rate Settings

We had tested the nodes for a distance of 10 meters. The Power consumption will change as per the distance as shown in Table-3. The flow chart for adaptive algorithm is shown Figure2. The algorithm is developed such that if the nodes are close to each other the transmission power and data rate is adjusted at lower level. As the distance increases, the transmission power and data rate goes on increasing.

4. Experimental results:-

The WSN nodes are arranged in the network as shown in Figure 3 where N1, N2, N3, N4, N5, N6 are the different Nodes. 'S' indicates the destination node which is connected to computer. The data from the network is processed and displayed by this computer. The Node lifetime depends upon the power consumption of MSP430, transmit and receive mode consumption of nRF24L01. Also it depends upon the sleep and active times i.e. duty cycle [7,8]. The node is programmed with <1% of duty cycle [9]. The Average current consumption and the node lifetime are calculated by taking the different parameters as shown in Table 4.

Distance Between Nodes (Meter)	RF Output Power	DC Current Consumption	RF Output mV	Settings At PWR_UP Register	Output Rate Adjustment (Mbps)
8 to 10	0 dBm	11.3 mA	56.5	11	2
6 to 8	-6 dBm	9.0 mA	45	10	2
3 to 6	-12 dBm	7.5 mA	37.5	01	1
0 to 3	-18 dBm	7.0 mA	35	00	1

Table-3 Output power and rate settings for Adaptive power control Algorithm

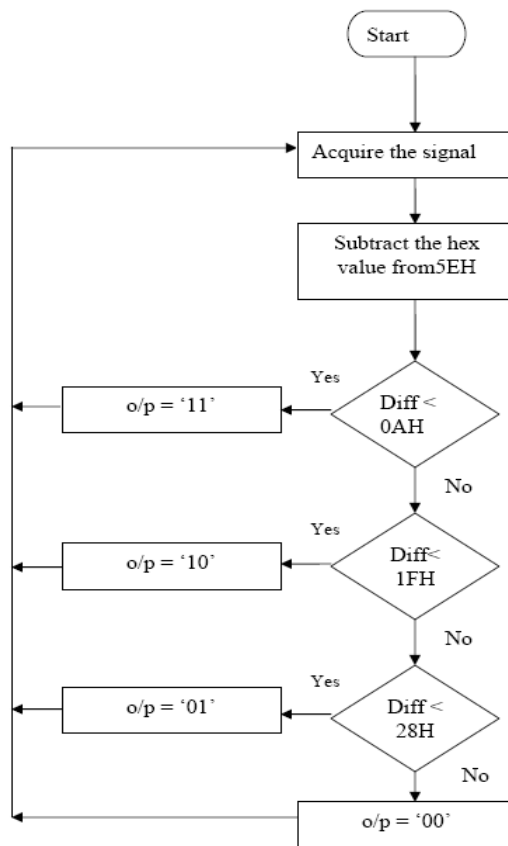

Fig. 2 Adaptive power control Algorithm Flow chart

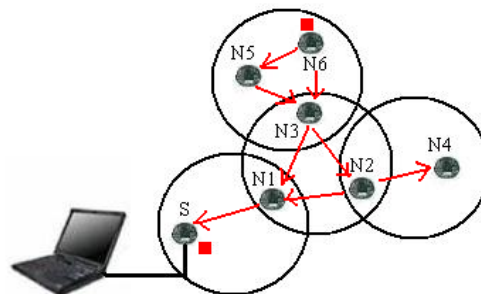

Figure 3 Intercommunication between the nodes

As Node 1 is very close to destination 'S', instead of constant power of 0 dbm the node can be set to lowest power at -18 dbm. This will increase battery lifetime from 4.2 years to 7 Years as shown in Figure 4.

This will apply to all other nodes. Each will set its power to different levels depending upon the distance between Node and destination Node 'S'.



Parameter	Settings	Unit
Overhead	65	bits
Payload length	8	bits
Packet length	73	bits
Bit rate	2000000	bits/sec
Time on air	0.3	sec
Time in RX	0.00003252	sec
MCU+TX Current	11.6	mA
MCU+RX current	12.9	mA
PLL- Lock time	0.00013	sec
PLL- Lock TX current	8	mA
PLL- Lock RX current	8.4	mA
Power_Dn current	0.0009	mA
Duty-cycle period	55.7	sec
Power_up current	0.285	mA
Power_up time	0.0015	sec
I (avg)	0.06342619	mA
Battery Rating	2450	mAh
Lifetime	38627.5768	hours
	1609.48237	days
	4.42165486	years

Table- 4 Node lifetime calculations for 0dBm power

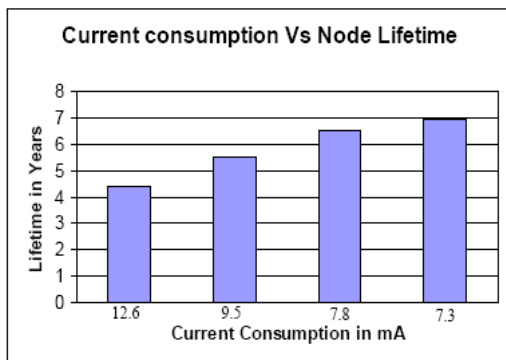

Figure 4 Node lifetime for various transmitter levels of nRF24L01

The WSN Node designed Cost Details for one Node is given in Table5:

Sr. No	Name of the Component	Cost
1.	MSP430F2013	0.5 \$
2.	nRf24L01	1.2 \$
3.	Crystal	0.1 \$
4.	Antenna & other Components	0.3 \$
5.	PCB Development	0.1 \$
6.	Battery	0.3 \$
	Total Cost	2.4 \$

Table-5 Cost Analysis of the WSN node

If we manufacture the nodes in bulk, then the cost will be reduced around 1\$. Thus we get a cost effective solution through this design for various applications in automobiles also [10].

5. Conclusion

We have designed a very compact node with maximum possible power efficiency. The node has many ports available for future expansion of the nodes. The Power management occurs as Low duty cycle is considered. We have developed our own protocol stack efficient than Zigbee with simple programming compilers like cross studio.

The adaptive algorithm saves the power to a great extent as at high power level transmission due to high data rate the transmission will be faster causing the node ON time to be reduced. The transmission time is almost half than required by 1 Mbps rate. Hence the battery life can be further increased.

6. References

- [1] Akyildiz, W. Su, Y. Sankarasubramaniam and E. Cayirci. A survey on Sensor Networks. IEEE Communications Magazine, vol. 40, Issue: 8, pp. 102-114, August 2002.
- [2] S. S. Sonavane, V. Kumar and B. P. Patil. Design Factors, Requirements and Research issues of wireless Sensor Networks. International journal of Engineering Research & Industrial Applications (IJERIA), Vol.1, No. III, pp 79-93, 2008.
- [3] <http://www.ti.com/msp430/datasheet> accessed on 20th August 2008.
- [4] <http://www.nordicsemiconductor.com/nrf24L01> accessed on 10th sept. 2008.



- [5] S. S. Sonavane, V. Kumar and B. P. Patil. Component Choice for Low Power Wireless Sensor Networks Node. International Journal of Computer, Information Technology and Engineering (IJCITAE), Vol.2, No.1, July-2008, Series Publications.
- [6] D. Estrin, D. Culler, K. Pister and G. Sukhatme. Connecting the physical world with pervasive networks. IEEE Pervasive Computing, 1(1), Jan- 2002.
- [7] S. S. Sonavane, B. P. Patil and V. Kumar. Designing Wireless Sensor Network with Low cost and Low Power. International Conferences On Networking (ICON) to be held at IIT Roorkee on 12th Dec-08.
- [8] S. S. Sonavane, B. P. Patil, V. Kumar. Energy Efficient protocols Wireless Sensor Network: an Overview. In proceedings of International Conference on Computer and Communication Engineering (ICCCE08) at Department of Electrical and Computer Engineering, International Islamic University, Malaysia (IIUM), May-2008.
- [9] Joseph Polastre, Robert Szewczyk, and David Culler. Telos: Enabling ultra-low power wireless research. The Fourth International Conference on Information Processing in Sensor Networks: Special track on Platform Tools and Design Methods for Network Embedded Sensors (IPSN/SPOTS), Los Angeles, California, April 2005.
- [10] Fred Yu, Bozena Kaminska and Pawel Gburzynski. A Wireless Sensor-Based Driving Assistant for Automobiles. ICGST-ACSE Journal, ISSN 1687-4811, Volume 8, Issue II, December 2008.



Dr. V. Kumar received Ph.D in 1980 and worked as Scientist at CMRI, Dhanbad and Visiting Scientist at CNR, Frascati, Roma, Italy during 1983-84. He has attended number of International Conferences including conferences held in USA,

Portugal, Singapore and Italy. At present, he is Associate Professor and Head of Electronic & Instrumentation Department, ISM University, Dhanbad. He has published over 100-research papers; guided 2-Ph.D. and number of M. Tech students in the areas of Opto-electronic materials and Optical Fiber Sensors.



Dr. B. P. Patil received his Ph.D. in 2000 and has more than 18 years of teaching and industrial experience. He has published 41 papers in International journals and Conferences also guiding two Ph.D. students. He is

currently working as Professor and Head of Electronics Engineering Dept. at Maharashtra Academy of Engineering (MAE), Alandi, and Pune. His area of research includes sensor network, wireless communication.

7. Biographies



Sonavane S. S. is currently pursuing his Ph.D. from Indian School of mines, Dhanbad. He is currently working as Assistant Professor in Dept. of Electronics and Telecommunication Engg. in Rajarshi Shahu College of Engineering, Pune. He has published around 18

papers in International and National journals and Conferences.

