



u-blox AG
Zürcherstrasse 68
8800 Thalwil
Switzerland
www.u-blox.com

Phone +41 44 722 7444
Fax +41 44 722 7447
info@u-blox.com

NEO-4S ANTARIS[®] 4 ROM-Based GPS Module with SuperSense[®]

Data Sheet



Abstract

Technical description of an ultra-small low-cost SuperSense ANTARIS[®]4 GPS Module with serial and USB interface, designed for use with passive and active antennas.

your position is our focus

Data Sheet

Title	NEO-4S		
Subtitle	ANTARIS® 4 ROM-Based GPS Module with SuperSense®		
Doc Type	Data Sheet		
Doc Id	GPS.G4-MS4-06107		
Revision Index	Date	Name	Status / Comments
P1	05. Oct 2006	TN	Preliminary release
-	12. Feb 2007	TG	Release

We reserve all rights to this document and the information contained therein. Reproduction, use or disclosure to third parties without express permission is strictly prohibited.

For most recent documents, please visit www.u-blox.com

Data Sheet Revisions	Identification of applicable hardware	Comments
P1	All data codes	
-	All data codes	

	<p>Products marked with this lead-free symbol on the product label comply with the "Directive 2002/95/EC of the European Parliament and the Council on the Restriction of Use of certain Hazardous Substances in Electrical and Electronic Equipment" (RoHS).</p>
---	---

Performance characteristics shown in this document are estimates only and do not constitute a warranty or guarantee of product performance. u-blox does not support any applications in connection with weapon systems. Since u-blox' products are not designed for use in life-support and commercial aviation applications they shall not be used in such products. In devices or systems whereby malfunction of these products can be expected to result in personal injury and casualties, u-blox customers using or selling these products do so at their own risk and agree to keep u-blox harmless from any consequences. u-blox reserves the right to make changes to this product, including its circuits and software, in order to improve its design and/or performance, without prior notice.

u-blox makes no warranties, neither expressed nor implied, regarding the information and specifications contained in this document. u-blox assumes no responsibility for any claims or damages arising from information contained in this document, or from the use of products and services detailed therein. This includes, but is not limited to, claims or damages based on the infringement of patents, copyrights, mask work and/or other intellectual property rights.

u-blox integrated circuits, software and designs are protected by intellectual property laws in Switzerland and abroad. u-blox, the u-blox logo, the TIM-type GPS module, Antaris, SuperSense, "your position is our focus", NavLox, u-center, AssistNow, AlmanacPlus, FixNow and EKF are (registered) trademarks of u-blox AG. This product may in whole or in part be subject to intellectual property rights protection. Please contact u-blox for any additional information. Copyright © 2007, u-blox AG.

1 Functional Description

1.1 Overview

The NEO-4S module packs high sensitivity, exceptionally low power consumption and a USB port into a miniature 12.2 x 16 mm package. Its -158 dBm tracking sensitivity extends positioning coverage and enables solutions that use smaller or covert antennas.

The NEO-4S provides an SPI interface to connect an optional external serial E²PROM to store power-up configuration settings. This novel method is much more flexible than the limited number of boot-time configuration pins used in other modules.

Its small form factor and SMT pads allow for fully automatic assembly processes with standard pick-and-place equipment and reflow soldering, enabling cost-efficient, high-volume production. This makes NEO-4S modules perfectly suited for mass-market end products with strict size, power consumption and costs requirements.

1.2 Block Diagram

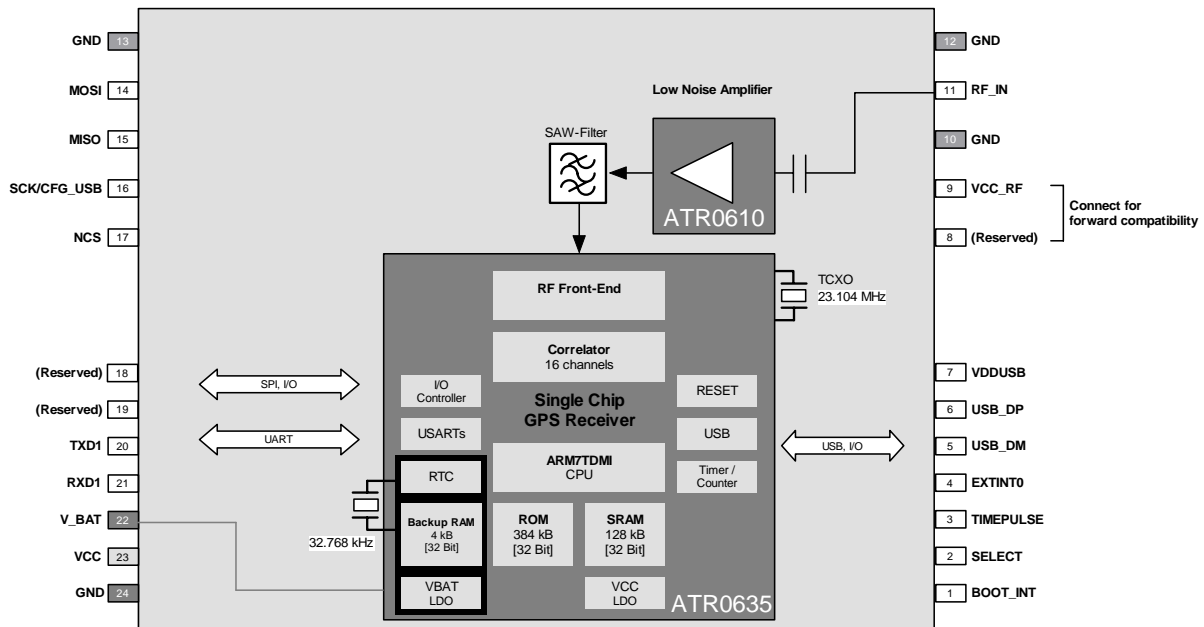

Figure 1: Block Diagram

1.3 Highlights

- **SuperSense Indoor GPS**
- **Ultra low power consumption**
- **Cost-optimized architecture (No Flash EPROM)**
- **Supports A-GPS services including AssistNow® Online**
- **4 Hz position update rate**
- **1 USB and 1 UART port**
- **Interface to optional serial E²PROM for configuration settings**

1.4 Features

- 16 channel ANTARIS®4 positioning engine
- Supports DGPS, WAAS, EGNOS and MSAS
- Power saving modes
- Supports passive and active antennas
- Power brown-out protection: No external reset hardware needed
- Operating temperature range: –40 to 85°C
- RoHS compliant (lead-free)

1.5 Operating Modes

The ANTARIS® 4 GPS Technology supports following Operating Modes:

Operating Modes	Description
Continuous Tracking Mode (CTM)	In this mode, the Autonomous Power Management (APM) automatically optimizes power consumption. It powers off parts of the receiver when they are not used. Also, the CPU speed is reduced when the CPU workload is low.
Power Saving Modes	A configurable power saving mode is available where the GPS is put into sleep mode and activated up on a selectable time interval or upon external request (signal activity on serial port or EXTINT input). This mode is ideally suited in applications with stringent power budget requirements in mobile and battery operated end products.

Table 1: Operating Modes

For more information see the *ANTARIS® 4 System Integration Manual* [1].

1.6 Protocols

The NEO-4S supports different serial protocols.

Protocol	Type	Runs on
NMEA	Input/output, ASCII, 0183, 2.3 (compatible to 3.0)	All serial ports and USB
UBX	Input/output, binary, u-blox proprietary	All serial ports and USB
RTCM	Input, message 1,2,3,9	All serial ports and USB

Table 2: Available Protocols

For specification of the various protocols see the *Protocol Specification* [2].

1.7 Antenna

This GPS receiver is designed for use with passive and active antennas.

Parameter	Specification						
Antenna Type	Active and passive antennas						
Active Antenna Recommendations	<table border="0"> <tr> <td>Minimum gain</td> <td>15 - 20 dB (to compensate signal loss in RF cable)</td> </tr> <tr> <td>Maximum noise figure</td> <td>1.5 dB</td> </tr> <tr> <td>Maximum gain</td> <td>50 dB</td> </tr> </table>	Minimum gain	15 - 20 dB (to compensate signal loss in RF cable)	Maximum noise figure	1.5 dB	Maximum gain	50 dB
Minimum gain	15 - 20 dB (to compensate signal loss in RF cable)						
Maximum noise figure	1.5 dB						
Maximum gain	50 dB						
Antenna Supply	Using VCC_RF or external voltage source						
Antenna Supervisor	No						

Table 3: Antenna Specification

1.8 Assisted GPS (A-GPS)

The ANTARIS® 4 GPS engine supports Mobile Station (MS) based A-GPS for accelerated acquisition and position computation in the GPS receiver. Supply of aiding information like ephemeris, almanac, rough last position and time and satellite status and an optional time synchronization signal will reduce time to first fix significantly. The NEO-4S supports the u-blox AssistNow® Online A-GPS service. AssistNow® Offline is not available.

1.9 External Serial E²PROM

The NEO-4S provides an SPI interface to connect an optional external serial E²PROM to store power-up configuration settings. This novel method is much more flexible than the limited number of boot-time configuration pins used in other modules. A low level at the SELECT pin will enable this feature.

For information regarding supported E²PROMs and a sample diagram please consult the document *Connecting serial EEPROM to NEO-4S* [3].

1.10 USB Configuration

When using the USB interface, the USB must be configured whether it is self-powered or bus powered. Two means are possible: With configuration pin, and with serial E²PROM.

Please refer to the *ANTARIS[®] 4 System Integration Manual* [1].

2 GPS Performance

Parameter	Specification				
Receiver Type	L1 frequency, C/A Code, 16-Channels				
Max Navigation Update Rate	4 Hz				
Accuracy	Position	2.5 m CEP ²	5.0 m SEP ³		
	Position DGPS / SBAS ¹	2.0 m CEP	3.0 m SEP		
Acquisition ^{4, 5}	GPS Mode (UBX-CFG Msg):	Fast Acquisition Mode	Normal Mode	High Sensitivity Mode	Auto Mode
	Cold Start	34 s	36 s	41 s	34 s
	Warm Start	33 s			
	Hot Start	<3.5 s			
	Reacquisition	<1 s			
Sensitivity ⁶	Tracking	-158 dBm			
	Acquisition & Reacquisition	-148 dBm			
	Cold Starts	-142dBm			
Accuracy of Timepulse Signal	RMS	50 ns			
	99%	<100 ns			
	Granularity	43 ns			
Dynamics	Strong signals	≤ 4 g			
	Weak signals	typ. 1 g			
Operational Limits	Velocity	515 m/s			

Table 4: GPS Performance

¹ Depends on accuracy of correction data of DGPS or SBAS service

² CEP = Circular Error Probability: The radius of a horizontal circle, centered at the antenna's true position, containing 50% of the fixes.

³ SEP = Spherical Error Probability. The radius of the sphere, centered at the true position, contains 50% of the fixes.

⁴ The different start-up modes like cold, warm and hot start are described in the *ANTARIS[®]4 System Integration Manual* [1]

⁵ Measured with good visibility and -125 dBm signal strength

⁶ Demonstrated with a good active antenna. Sensitivity will reduce by 2 dB when using passive antennas.

3 Mechanical Specification

3.1 Dimensions

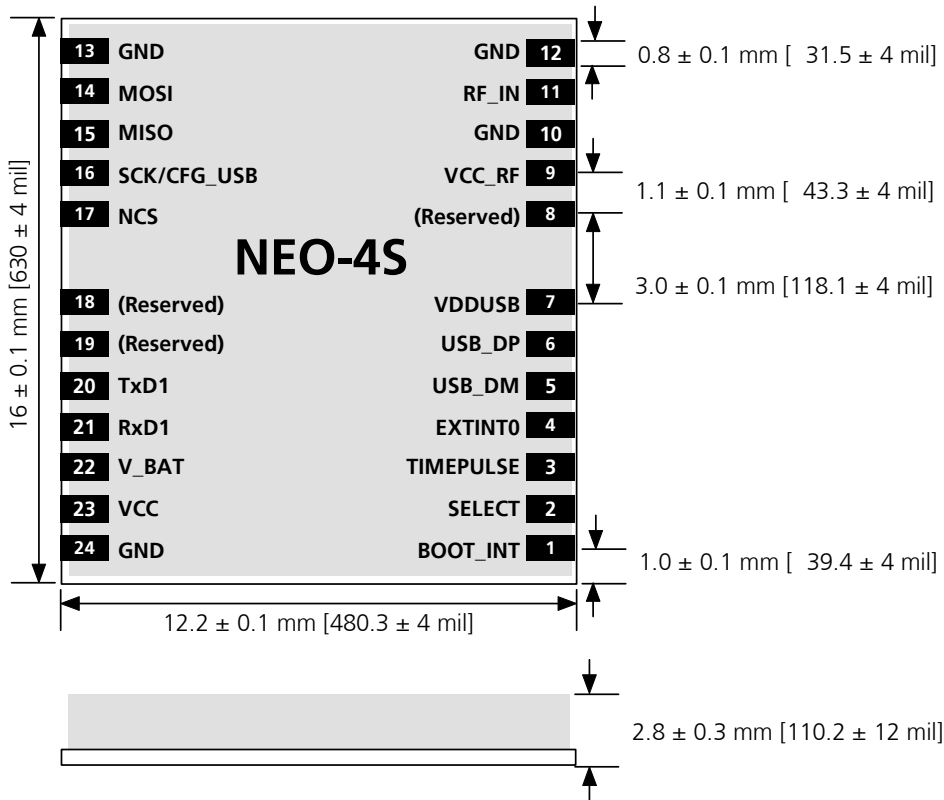

Figure 2: NEO-4S Dimensions

3.2 Specification

Parameter	Specification	Tolerance	Unit
Length	16.0	± 0.1	mm
Width	12.2	± 0.1	mm
Thickness	2.8	± 0.3	mm
Pitch RF pins	1.1	± 0.1	mm
Pitch digital pins	1.1	± 0.1	mm
Weight	1.6		g

Table 5: Mechanical Specification

3.3 Pin Assignment

Standard Function				Remarks
No	Name	I/O	Description	
1	BOOT_INT	I	Boot mode	
2	SELECT	I	Mode Selector Pin	Allows selection between default configuration and configuration storage to EEPROM. See Table 11 for details. Never leave this pin open.
3	TIMEPULSE	O	Time pulse (1PPS)	
4	EXTINT0	I	External Interrupt Pin	
5	USB_DM	I/O	USB Data	
6	USB_DP	I/O	USB Data	
7	VDDUSB	I	USB Supply	Connect to 3...3.6V when using USB Connect to GND when USB is not used Never leave this pin open
8	(Reserved)	I		Must connect pins 8 and 9 together for forward compatibility
9	VCC_RF	O	Output Voltage RF section	
10	GND	I	Ground	
11	RF_IN	I	GPS signal input	
12	GND	I	Ground	
13	GND	I	Ground	
14	MOSI	O	SPI MOSI	
15	MISO	I	SPI MISO	
16	SCK / CFG_USB	O/I	SPI Clock / USB Power Mode	Function depends on SELECT pin
17	NCS	O	SPI chip select	
18	(Reserved)	I		Must leave open for future compatibility
19	(Reserved)	I	Production test pin	Must leave open all times
20	TxD1	O	Serial Port 1	
21	RxD1	I	Serial Port 1	
22	V_BAT	I	Backup voltage supply	
23	VCC	I	Supply voltage	
24	GND	I	Ground	

Table 6: Signals and Module Interface

For more information see the *ANTARIS® 4 System Integration Manual* [1].

4 Electrical Specification

4.1 Absolute Maximum Ratings

Parameter	Symbol	Min	Max	Units
Power Supply				
Power supply voltage (VCC)	Vcc	-0.3	3.6	V
Backup battery voltage (V_BAT)	Vbat	-0.3	3.6	V
Input Pins				
Digital input pin voltage (except VDDUSB, USB_DP, USB_DM)	Vin	-0.3	5	V
Input pin voltage VDDUSB	Vin_usb	-0.3	3.6	V
Input pin voltage USB_DP, USB_DM	Vin_usbio	-1	4.6	V
Voltage Supply output for Active Antenna and RF Section				
VCC_RF output current	Iccrf		50	mA
RF Input				
Input power at RF_IN (source impedance 50Ω, continuous wave)	Prfin		-5	dBm
Environment				
Storage temperature	Tstg	-40	85	°C

Table 7: Absolute Maximum Ratings

- ! Warning** Stressing the device beyond the “Absolute Maximum Ratings” may cause permanent damage. These are stress ratings only. The product is not protected against overvoltage or reversed voltages. If necessary, voltage spikes exceeding the power supply voltage specification, given in table above, must be limited to values within the specified boundaries by using appropriate protection diodes.

4.2 Operating Conditions

Parameter ⁷	Symbol	Condition	Min	Typ	Max	Units
Power Supply						
Power supply voltage (VCC)	Vcc		2.7		3.3	V
Power supply voltage ripple	Vcc_PP				50	mV
Sustained supply current ⁸	Icc	Vcc = 3.0 V		38		mA
Peak supply current ⁹	Iccp	Vcc = 3.3 V			70	mA
Sleep mode current	Iccs	Vcc = 3.0 V		1.5		mA
Backup battery voltage	Vbat		1.5		3.6	V
Backup battery current	Ibat	Vbat = 3.3V		18		µA
UART and all I/O Signals¹⁰						
Input pin voltage range	Vin		0		5	V
Input pin low voltage	Vin_low				0.41	V
Input pin high voltage	Vin_high		1.46			V
Output pin voltage range	Vout		0		VCC	V
Output pin low voltage	Vout_low	Iout = 1.5 mA			0.4	V
Output pin high voltage	Vout_high	Iout = -1.5 mA	VCC-0.5			V
USB						
VDDUSB (Pin 24) for USB operation	Vddusb1		3.0		3.6	V
VDDUSB (Pin 24) if USB not used (low)	Vddusb0		0		2	V
USB_DM, USB_DP	VinU	Compatible with USB with 27 Ohms series resistance				
RF input						
Antenna gain	Gant				50	dB
VCC_RF voltage	Vccrf			Vcc - 0.1		V
VCC_RF output current	Iccrf				50	mA
Environment						
Operating temperature	Topr		-40		85	°C

Table 8: Operating Conditions

Running this device beyond the "Operating Conditions" is not recommended and extended exposure beyond them may affect its reliability.

⁷ All specification are at an ambient temperature of 25°C.

⁸ Average current drawn during Continuous Tracking Mode with 1 Hz update rate, using 9 channels for tracking and navigation and 3 channels for searching satellites (= acquisition). Use this figure to determine required battery capacity.

⁹ Peak current drawn during initial acquisition phase. Use this figure to dimension maximum current capability of power supply.

¹⁰ RxD1 and EXTINT0 provide internal pull-up to V_BAT18 (Battery supply regulated to 1.8V) and not VCC.

5 Environmental Specification

Detailed description of the test series:

Test		Standard
Visual inspection		IPC-A-610 "Acceptability of electronic assemblies" I.T.R.I. Publication No. 700 IPC-SM-840B Class 2.
Thermal shock	-40°C...+125°C, 100 cycles	IEC 68-2-14
Function at various temperatures	-40°C/2 hours; RT/2 hours; +85°C/2 hours; function tests at stable temperature	IEC 68-2-1 and IEC 68-2-2
Lifespan test	+85°C/1000 hours, in function	IEC 68-2-2
Vibration	10-500 Hz; 2 hours/axis; 5g	IEC 68-2-6
Shock	30g/11ms (halfsine); 3 Shock/axis; no function	IEC 68-2-27
Metallographic investigations		IPC-QE-650

Note: This specification is preliminary and yet subject to confirmation.

Table 9: Environmental Specification

6 Settings

6.1 Default Settings

Interface	Settings
Serial Port 1 Output	9600 Baud, 8 bits, no parity bit, 1 stop bit Configured to transmit both NMEA and UBX protocols, but only following NMEA and no UBX messages have been activated at start-up: GGA, GLL, GSA, GSV, RMC, VTG, ZDA, TXT
Serial Port 1 Input	9600 Baud, 8 bits, no parity bit, 1 stop bit, Autobauding disabled Automatically accepts following protocols without need of explicit configuration: UBX, NMEA, RTCM The GPS receiver supports interleaved UBX and NMEA messages.
USB Output	Same protocol and message set as via Serial Port 1 USB Power Mode: Self Powered
USB Input	Same protocol and message set as via Serial Port 1 USB Power Mode: Self Powered
TIMEPULSE	1 pulse per second, synchronized at rising edge, pulse length 100ms

Table 10: Available Protocols

Sensitivity Mode	Remark
Auto	The sensitivity mode can be changed with the CFG-RXM message.

Table 11: NEO-4S sensitivity settings

Please refer to the *ANTARIS® 4 System Integration Manual* [1] for information about further settings.

7 Product Lineup

7.1 Ordering Information

Ordering No.	Product
NEO-4S-0-000-0	NEO-4S ROM-Based GPS Module with SuperSense <u>Delivery Packing</u> 0 = Single samples 2 = Tape on reel (250 pieces)

Table 12: Ordering Information

Related Documents

- [1] ANTARIS® 4 System Integration Manual, Doc No GPS.G4-MS4-05007
- [2] ANTARIS® 4 Protocol Specification, Doc No GPS.G3-X-03002
- [3] Connecting serial EEPROM to NEO-4S, Doc No GPS.G4-MS4-06138

All these documents are available on our homepage (<http://www.u-blox.com>).

Contact

For further info, please contact us:

Headquarters

u-blox AG

Zuercherstrasse 68
CH-8800 Thalwil
Switzerland

Phone: +41 44 722 74 44
Fax: +41 44 722 74 47
E-mail: info@u-blox.com

www.u-blox.com

Sales Offices

North, Central and South America

u-blox America, Inc.

1902 Campus Commons Drive
Suite 310
Reston, VA 20191
USA

Phone: +1 (703) 483 3180
Fax: +1 (703) 483 3179
E-mail: info_us@u-blox.com

Regional Office West Coast:

8600 Lemon Ave #1
La Mesa, CA 91941
USA

Phone: +1 (619) 741 3011
Fax: +1 (619) 741 4334
E-mail: info_us@u-blox.com

Technical Support:

Phone: +1 (703) 483 3185
E-mail: support_us@u-blox.com

Europe, Middle East, Africa

u-blox AG

Zuercherstrasse 68
CH-8800 Thalwil
Switzerland

Phone: +41 44 722 74 77
Fax: +41 44 722 74 47
E-mail: info@u-blox.com

Technical Support:

Phone: +41 44 722 74 74
E-mail: support@u-blox.com

Asia, Australia, Pacific

u-blox Singapore Pte. Ltd.

435 Orchard Road
#19-02, Wisma Atria,
Singapore 238877

Phone: +65 6734 3811
Fax: +65 6736 1533
E-mail: info_ap@u-blox.com
Support: support_ap@u-blox.com

Regional Office China:

Room 716-718
No. 65 Fuxing Road
Beijing, 100036, China

Phone: +86 10 68 133 545
Fax: +86 10 68 217 890
E-mail: info_cn@u-blox.com
Support: support_cn@u-blox.com

Regional Office Korea:

1258 Ho, Shinhan MetroKhan
#1115, BisanDong
DongAn-Ku
Anyang-si
KyungKi-do, Korea

Phone: +82 31 383 2584
Fax: +82 31 386 2584
E-mail: info_kr@u-blox.com
Support: support_kr@u-blox.com

Regional Office Taiwan:

Room 305
3F, #181, ZouTze Street
Neihu Dis.
Taipei, Taiwan

Phone: +886 2 2657 1090
Fax: +886 2 2657 1097
E-mail: info_tw@u-blox.com
Support: support_tw@u-blox.com