

SIEMENS

TC35i

Siemens Cellular Engines

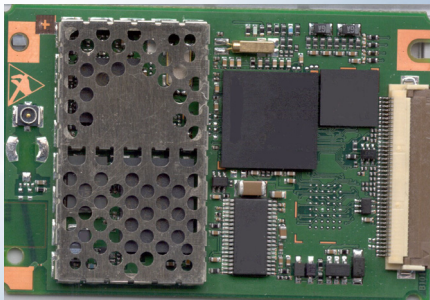

Hardware Interface Description

Version: 00.03
DocID: TC35i_HD_V00.03

Wireless Modules

Document Name: **TC35i Hardware Interface Description**
Version: **00.03**
Date: **January 22, 2003**
DocId: **TC35i_HD_V00.03**
Status: **Ready for distribution to customers**

General notes

Product is deemed accepted by Recipient and is provided without interface to Recipient's products. The Product constitutes pre-release version and code and may be changed substantially before commercial release. The Product is provided on an "as is" basis only and may contain deficiencies or inadequacies. The Product is provided without warranty of any kind, express or implied. To the maximum extent permitted by applicable law, Siemens further disclaims all warranties, including without limitation any implied warranties of merchantability, fitness for a particular purpose and noninfringement of third-party rights. The entire risk arising out of the use or performance of the Product and documentation remains with Recipient. This Product is not intended for use in life support appliances, devices or systems where a malfunction of the product can reasonably be expected to result in personal injury. Applications incorporating the described product must be designed to be in accordance with the technical specifications provided in these guidelines. Failure to comply with any of the required procedures can result in malfunctions or serious discrepancies in results. Furthermore, all safety instructions regarding the use of mobile technical systems, including GSM products, which also apply to cellular phones must be followed. Siemens AG customers using or selling this product for use in any applications do so at their own risk and agree to fully indemnify Siemens for any damages resulting from illegal use or resale. To the maximum extent permitted by applicable law, in no event shall Siemens or its suppliers be liable for any consequential, incidental, direct, indirect, punitive or other damages whatsoever (including, without limitation, damages for loss of business profits, business interruption, loss of business information or data, or other pecuniary loss) arising out the use of or inability to use the Product, even if Siemens has been advised of the possibility of such damages. Subject to change without notice at any time.

Copyright notice

Copying of this document and giving it to others and the use or communication of the contents thereof, are forbidden without express authority. Offenders are liable to the payment of damages. All rights reserved in the event of grant of a patent or the registration of a utility model or design.

Copyright © Siemens AG 2003

Trademark notice

MS Windows® is a registered trademark of Microsoft Corporation.

Contents

0	Version history	7
1	Introduction	8
1.1	Related documents	8
1.2	Terms and abbreviations.....	9
1.3	Standards	12
1.4	Safety Precautions	14
2	Product overview	16
2.1	TC35i key features at a glance	17
2.2	Circuit concept	19
3	Application Interface.....	20
3.1	Operating modes	21
3.2	Power supply	22
3.2.1	Power supply pins on the ZIF connector.....	23
3.2.2	Minimizing power losses.....	24
3.2.3	Monitoring power supply.....	24
3.3	Power up / down scenarios	25
3.3.1	Turn on the GSM engine	25
3.3.1.1	Turn on GSM engine using the ignition line IGT (Power on).....	25
3.3.1.2	Timing of the ignition process.....	26
3.3.1.3	Turn on GSM engine using the POWER lines.....	27
3.3.1.4	Turn on GSM engine using the RTC (Alarm mode).....	27
3.3.2	Turn off GSM engine.....	28
3.3.2.1	Turn off GSM engine using AT command	28
3.3.2.2	Emergency shutdown using /EMERGOFF pin.....	29
3.3.3	Automatic shutdown	30
3.3.3.1	Temperature dependent shutdown.....	30
3.3.3.2	Temperature control during emergency call	31
3.3.3.3	Monitoring the board temperature of TC35i.....	31
3.3.3.4	Shutdown in the event of undervoltage.....	32
3.3.3.5	Shutdown in the event of overvoltage.....	32
3.3.4	Battery pack	33
3.3.4.1	Recommended battery pack.....	34
3.3.4.2	Implemented charging technique.....	34
3.3.4.3	Operating modes during charging	36
3.3.4.4	Charger requirements	37
3.4	Power saving	38
3.4.1	No power saving (AT+CFUN=1).....	38
3.4.2	NON-CYCLIC SLEEP mode (AT+CFUN=0).....	38
3.4.3	CYCLIC SLEEP mode (AT+CFUN=5, 6, 7 and 8)	38
3.4.4	Timing of the /CTS signal in CYCLIC SLEEP modes	39
3.4.5	Wake up TC35i from SLEEP mode.....	41
3.4.6	Summary of state transitions (except SLEEP mode).....	42
3.5	RTC backup.....	43
3.6	Serial interface.....	45
3.7	Audio interface.....	47
3.7.1	Speech processing.....	48

3.8	SIM interface.....	49
3.8.1	Requirements for using the CCIN pin.....	50
3.8.2	Design considerations for SIM card holder.....	51
3.9	Control signals.....	52
3.9.1	Inputs.....	52
3.9.2	Outputs.....	53
3.9.2.1	Synchronization signal.....	53
3.9.2.2	Using the SYNC pin to control a status LED.....	54
3.9.2.3	Behaviour of the /RING0 line.....	55
4	RF interface.....	56
4.1	Antenna connector.....	57
5	Electrical, reliability and radio characteristics.....	60
5.1	Absolute maximum ratings.....	60
5.2	Operating conditions.....	60
5.2.1	Temperature conditions.....	60
5.3	Electrical specifications of the application interface.....	61
5.4	Power supply ratings.....	65
5.4.1	Current consumption during transmit burst.....	66
5.5	Electrical characteristics of the voiceband part.....	67
5.5.1	Setting audio parameters by AT command.....	67
5.5.2	Audio programming model.....	68
5.5.3	Characteristics of audio modes.....	69
5.5.4	Voiceband receive path.....	70
5.5.5	Voiceband transmit path.....	71
5.6	Air interface.....	72
5.7	Electrostatic discharge.....	73
5.8	Reliability characteristics.....	74
6	Mechanics.....	75
6.1	Mechanical dimensions of TC35i.....	75
6.2	Mounting TC35i onto the application platform.....	77
6.3	ZIF connector (application interface).....	78
6.3.1	FFC.....	78
6.3.2	Mechanical dimensions of Hirose FH12-40S 0.5 SH connector.....	79
7	Reference Approval.....	80
7.1	Reference Equipment.....	80
8	APPENDIX: List of parts and recommended accessories.....	81

Figures

Figure 1: Block diagram of TC35i	19
Figure 2: Block diagram of a cellular application	20
Figure 3: Power supply limits during transmit burst	24
Figure 4: Power-on by ignition signal.....	25
Figure 5: Timing of power-on process if VDDL P is not used	26
Figure 6: Timing of power-on process if VDDL P is fed from external source.....	26
Figure 7: Deactivating GSM engine by Power Down signal.....	29
Figure 8: Battery pack circuit diagram	33
Figure 9: Internal charging circuit	35
Figure 10: Charging process	35
Figure 11: Timing of /CTS signal (example for a 2.12 s paging cycle).....	39
Figure 12: Beginning of power saving if CFUN=5.....	40
Figure 13: RTC supply from capacitor	43
Figure 14: RTC supply from rechargeable battery.....	43
Figure 15: RTC supply from non-chargeable battery (e.g. a coin cell).....	43
Figure 16: Serial interface	45
Figure 17: Audio block diagram.....	47
Figure 18: SIM card holder of DSB35 Support Box	51
Figure 19: Pin numbers of Molex SIM card holder on DSB45 Support Box	51
Figure 20: TC35i output control signals	53
Figure 21: LED Circuit (Example).....	54
Figure 22: Incoming voice call	55
Figure 23: Incoming data call	55
Figure 24: URC transmission	55
Figure 25: Antenna connector circuit on TC35i.....	56
Figure 26: Mechanical dimensions of MuRata GSC connector (in mm).....	58
Figure 27: Maximum mechanical stress to the connector.....	59
Figure 28: How to use MuRata tool	59
Figure 29: Pin assignment (top view on TC35i).....	61
Figure 30: Current consumption during transmit burst.....	66
Figure 31: Current consumption during transmit burst.....	66
Figure 32: AT audio programming model	68
Figure 33: Structure of audio inputs	71
Figure 34: TC35i – top view.....	75
Figure 35: Mechanical dimensions of TC35i.....	76
Figure 36: Hirose FH12 connector	78
Figure 37: Description of Hirose FH12 connector.....	79
Figure 38: Reference equipment for approval	80

Tables

Table 1: TC35i key features	17
Table 2: Overview of operating modes	21
Table 3: Power supply pins of ZIF connector.....	23
Table 4: AT commands available in Alarm mode.....	27
Table 5: Temperature dependent behaviour.....	31
Table 6: Specifications of XWODA battery pack	34
Table 7: AT commands available in Charge-only mode.....	37
Table 8: Wake-up events in NON-CYCLIC and CYCLIC SLEEP modes.....	41
Table 9: State transitions of TC35i (except SLEEP mode)	42
Table 10: DCE-DTE wiring	45
Table 11: Signals of the SIM interface (board-to-board connector)	49
Table 12: Pin assignment of Molex SIM card holder on DSB35 Support Box.....	51
Table 13: Input control signals of the TC35i module.....	52
Table 14: TC35i synchronization signal (if SYNC pin is set to mode 0 via AT^SSYNC).....	53
Table 15: Modes of the LED and associated functions.....	54
Table 16: TC35i ring signal	55
Table 17: Return loss	56
Table 18: MuRata ordering information	57
Table 19: Ratings and characteristics of the GSC antenna connector.....	57
Table 20: Stress characteristics of the GSC antenna connector.....	59
Table 21: Absolute maximum ratings	60
Table 22: Temperature conditions.....	60
Table 23: Pin assignment and electrical description of application interface.....	62
Table 24: Power supply ratings	65
Table 25: Audio parameters adjustable by AT command	67
Table 26: Voiceband characteristics (typical), all values preliminary.....	69
Table 27: Voiceband receive path	70
Table 28: Voiceband transmit path.....	71
Table 29: Air Interface.....	72
Table 30: Local oscillator and intermediate frequencies used by TC35i	72
Table 31: Measured electrostatic values	73
Table 32: Summary of reliability test conditions.....	74
Table 33: Ordering information.....	78
Table 34: Electrical and mechanical characteristics of Hirose FH12-40S 0.5 SH connector.....	78
Table 35: List of accessories.....	81

0 Version history

Preceding document: "TC35i Hardware Interface Description" Version 00.02

New document: "TC35i Hardware Interface Description" Version **00.03**

Chapter	Page	What is new
5.4.1	66	Added Figure 30: Current consumption during transmit burst and Figure 31: Current consumption during transmit burst

Preceding document: "TC35i Hardware Interface Description" Version 00.01

New document: "TC35i Hardware Interface Description" Version **00.02**

Chapter	Page	What is new
3.3.3.3	31	Added new feature: Monitoring the board temperature of TC35i
3.3.4	33ff	Modified Chapter: Battery pack, added new Xwoda address
3.7	47	Added Table 30: Local oscillator and intermediate frequencies used by TC35i
3.8	49ff	Added information regarding CCIN pin and SIM card removal during operation. Modified Figure 18

1 Introduction

This document describes the hardware of the Siemens TC35i module that connects to the cellular device application and the air interface. As TC35i is intended to integrate with a wide range of application platforms, all functional components are described fully detailed.

So this guide covers all information you need to design and set up cellular applications incorporating the TC35i module. It helps you to quickly retrieve interface specifications, electrical and mechanical details and information on the requirements to be considered for integrating further components.

1.1 Related documents

- [1] AT Command Set for TC35i, Version 00.03
- [2] Application Note 16: Updating TC35i Firmware, (in preparation)
- [3] Release Note (in preparation)
- [4] DSB35 Support Box - Evaluation Kit for Siemens Cellular Engines
- [5] Multiplexer User's Guide
- [6] Application Note 14: Audio and Battery Parameter Download
- [7] Multiplex Driver Developer's Guide for Windows 2000 and Windows XP
- [8] Multiplexer Driver Installation Guide for Windows 2000 and Windows XP

Prior to using the GSM engine, be sure to carefully read and understand the latest product information provided in the Release Notes.

To visit the Siemens Website you can use the following link:

<http://www.siemens.com/wm>

1.2 Terms and abbreviations

Abbreviation	Description
ADC	Analog-to-Digital Converter
AFC	Automatic Frequency Control
AGC	Automatic Gain Control
ARFCN	Absolute Radio Frequency Channel Number
ARP	Antenna Reference Point
ASIC	Application Specific Integrated Circuit
BER	Bit Error Rate
BTS	Base Transceiver Station
CB or CBM	Cell Broadcast Message
CS	Coding Scheme
CSD	Circuit Switched Data
CPU	Central Processing Unit
CE	Conformité Européene (European Conformity)
DAI	Digital Audio Interface
DAC	Digital-to-Analog Converter
dBm0	Digital level, 3.14dBm0 corresponds to full scale, see ITU G.711, A-law
DCE	Data Communication Equipment (typically modems, e.g. Siemens GSM engine)
DCS 1800	Digital Cellular System, also referred to as PCN
DSB	Development Support Box
DSP	Digital Signal Processor
DSR	Data Set Ready
DTE	Data Terminal Equipment (typically computer, terminal, printer or, for example, GSM application)
DTR	Data Terminal Ready
DTX	Discontinuous Transmission
EFR	Enhanced Full Rate
EGSM	Enhanced GSM
EMC	Electromagnetic Compatibility
ESD	Electrostatic Discharge
ETS	European Telecommunication Standard
FDMA	Frequency Division Multiple Access
FFC	Flat Flexible Cable
FR	Full Rate
GMSK	Gaussian Minimum Shift Keying
GPRS	General Packet Radio Service

Abbreviation	Description
GSM	Global Standard for Mobile Communications
HiZ	High Impedance
HR	Half Rate
IC	Integrated Circuit
IMEI	International Mobile Equipment Identity
I/O	Input/Output
ISO	International Standards Organization
ITU	International Telecommunications Union
kbps	kbits per second
LED	Light Emitting Diode
Li-Ion	Lithium-Ion
Mbps	Mbits per second
MMI	Man Machine Interface
MO	Mobile Originated
MS	Mobile Station (GSM engine), also referred to as TE
MSISDN	Mobile Station International ISDN number
MT	Mobile Terminated
NTC	Negative Temperature Coefficient
PCB	Printed Circuit Board
PCL	Power Control Level
PCN	Personal Communications Network, also referred to as DCS 1800
PCS	Personal Communication System
PDU	Protocol Data Unit
PLL	Phase Locked Loop
PPP	Point-to-point protocol
PSU	Power Supply Unit
R&TTE	Radio and Telecommunication Terminal Equipment
RAM	Random Access Memory
RF	Radio Frequency
ROM	Read-only Memory
RMS	Root Mean Square (value)
RTC	Real Time Clock
Rx	Receive Direction
SAR	Specific Absorption Rate
SELV	Safety Extra Low Voltage
SIM	Subscriber Identification Module
SMS	Short Message Service

Abbreviation	Description
SRAM	Static Random Access Memory
TA	Terminal adapter (e.g. GSM engine)
TDMA	Time Division Multiple Access
TE	Terminal Equipment, also referred to as DTE
Tx	Transmit Direction
UART	Universal asynchronous receiver-transmitter
URC	Unsolicited Result Code
USSD	Unstructured Supplementary Service Data
VSWR	Voltage Standing Wave Ratio
ZIF	Zero Insertion Force
<i>Phonebook abbreviations</i>	
FD	SIM fixdialling phonebook
LD	Last dialling phonebook (list of numbers most recently dialled)
MC	Mobile Equipment list of unanswered MT calls (missed calls)
ME	Mobile Equipment phonebook
ON	Own numbers (MSISDNs)
RC	Mobile Equipment list of received calls
SM	SIM phonebook

1.3 Standards

TC35i is designed to comply with the directives and standards listed below. Please note that the product is still in a pre-release state and, therefore, type approval and testing procedures have not yet been completed.

Directives

99/05/EC	Directive of the European Parliament and of the council of 9 March 1999 on radio equipment and telecommunications terminal equipment and the mutual recognition of their conformity, in short referred to as R&TTE Directive 1999/5/EC
89/336/EC	Directive on electromagnetic compatibility
73/23/EC	Directive on electrical equipment designed for use within certain voltage limits (Low Voltage Directive)

Standards of type approval

ETS 300 607-1	Digital cellular telecommunications system (Phase 2); Mobile Station (MS) conformance specification; (equal GSM 11.10-1=>equal 3GPP TS 51.010-1)
ETSI EN 301 511	V7.0.1 (2000-12) Candidate Harmonized European Standard (Telecommunications series) Global System for Mobile communications (GSM); Harmonized standard for mobile stations in the GSM 900 and DCS 1800 bands covering essential requirements under article 3.2 of the R&TTE directive (1999/5/EC) (GSM 13.11 version 7.0.1 Release 1998)
ETSI EN 301 489-7	V1.1.1 (2000-09) Candidate Harmonized European Standard (Telecommunications series) Electro Magnetic Compatibility and Radio spectrum Matters (ERM); Electro Magnetic Compatibility (EMC) standard for radio equipment and services; Part 7: Specific conditions for mobile and portable radio and ancillary equipment of digital cellular radio telecommunications systems (GSM and DCS)
EN 60 950	Safety of information technology equipment (2000)

Requirements of quality

IEC 60068	Environmental testing
DIN EN 60529	IP codes

SAR requirements specific to handheld mobiles

Mobile phones, PDAs or other handheld transmitters and receivers incorporating a GSM module must be in accordance with the guidelines for human exposure to radio frequency energy. This requires the Specific Absorption Rate (SAR) of handheld TC35i based applications to be evaluated and approved for compliance with national and/or international regulations.

Since the SAR value varies significantly with the individual product design manufacturers are advised to submit their product for approval if designed for handheld operation. For European and US markets the relevant directives are mentioned below. It is the responsibility of the manufacturer of the final product to verify whether or not further standards, recommendations of directives are in force outside these areas.

Products intended for sale on US markets

ES 59005/ANSI C95.1 Considerations for evaluation of human exposure to Electromagnetic Fields (EMFs) from Mobile Telecommunication Equipment (MTE) in the frequency range 30MHz-6GHz

Products intended for sale on European markets

EN 50360 Product standard to demonstrate the compliance of mobile phones with the basic restrictions related to human exposure to electromagnetic fields (300 MHz - 3 GHz)

1.4 Safety Precautions

The following safety precautions must be observed during all phases of the operation, usage, service or repair of any cellular terminal or mobile incorporating TC35i. Manufacturers of the cellular terminal are advised to convey the following safety information to users and operating personnel and to incorporate these guidelines into all manuals supplied with the product. Failure to comply with these precautions violates safety standards of design, manufacture and intended use of the product. Siemens AG assumes no liability for customer failure to comply with these precautions.



When in a hospital or other health care facility, observe the restrictions on the use of mobiles. Switch the cellular terminal or mobile off, if instructed to do so by the guidelines posted in sensitive areas. Medical equipment may be sensitive to RF energy.

The operation of cardiac pacemakers, other implanted medical equipment and hearing aids can be affected by interference from cellular terminals or mobiles placed close to the device. If in doubt about potential danger, contact the physician or the manufacturer of the device to verify that the equipment is properly shielded. Pacemaker patients are advised to keep their hand-held mobile away from the pacemaker, while it is on.



Switch off the cellular terminal or mobile before boarding an aircraft. Make sure it cannot be switched on inadvertently. The operation of wireless appliances in an aircraft is forbidden to prevent interference with communications systems. Failure to observe these instructions may lead to the suspension or denial of cellular services to the offender, legal action, or both.



Do not operate the cellular terminal or mobile in the presence of flammable gases or fumes. Switch off the cellular terminal when you are near petrol stations, fuel depots, chemical plants or where blasting operations are in progress. Operation of any electrical equipment in potentially explosive atmospheres can constitute a safety hazard.



Your cellular terminal or mobile receives and transmits radio frequency energy while switched on. Remember that interference can occur if it is used close to TV sets, radios, computers or inadequately shielded equipment. Follow any special regulations and always switch off the cellular terminal or mobile wherever forbidden, or when you suspect that it may cause interference or danger.



Road safety comes first! Do not use a hand-held cellular terminal or mobile when driving a vehicle, unless it is securely mounted in a holder for handsfree operation. Before making a call with a hand-held terminal or mobile, park the vehicle.

Handsfree devices must be installed by qualified personnel. Faulty installation or operation can constitute a safety hazard.

**IMPORTANT!**

Cellular terminals or mobiles operate using radio signals and cellular networks cannot be guaranteed to connect in all conditions. Therefore, you should never rely solely upon any wireless device for essential communications, for example emergency calls.

Remember, in order to make or receive calls, the cellular terminal or mobile must be switched on and in a service area with adequate cellular signal strength.

Some networks do not allow for emergency calls if certain network services or phone features are in use (e.g. lock functions, fixed dialling etc.). You may need to deactivate those features before you can make an emergency call.

Some networks require that a valid SIM card be properly inserted in the cellular terminal or mobile.

Confidential

2 Product overview

The TC35i GSM engine operating in the GSM 900 MHz and GSM 1800 MHz frequency band is an extremely compact and super slim communication module especially designed for telemetry, telematic and telephony such as: metering, fleet management, security systems, POS terminals or vending machines. It is compatible with the predecessor engine TC35 and offers additional features such as SIM application tool kit and extended AT commands for the industrial environment. Please note that the upper voltage limit has been changed from 5.5V to 4.8V.

The physical interface to the cellular application is made through a ZIF connector. It consists of 40 pins, required for controlling the unit, transferring data and audio signals and providing power supply lines.

The cellular device application forms the Man-Machine Interface (MMI). The serial interface allows for access to the GSM engine.

For battery powered applications, TC35i features a charging control which can be used to charge a Li-Ion battery.

2.1 TC35i key features at a glance

Table 1: TC35i key features

Feature	Implementation
Power supply (typical)	Single supply voltage 3.3V – 4.8V
Power saving	Current power consumption while remaining in SLEEP mode: 3mA
Charging	TC35i comprises an internal charging circuit
GSM class	Small MS
Frequency bands	Dual Band EGSM 900 and GSM 1800 Compliant to GSM Phase 2/2+
Transmit power	Class 4 (2W) at EGSM 900 Class 1 (1W) at GSM 1800
Temperature range	Normal operation: -20°C to +55°C Restricted operation: -25°C to +70°C Auto switch-off: >+75°C and <-25°C
Temperature control	When an emergency call is in progress the automatic temperature shutdown function is deactivated
SMS	MT, MO, CB, Text and PDU mode SMS storage: SIM card and in addition 25 SMS locations in the mobile equipment
DATA	Transmission rates: 2.400, 4.800, 9.600, 14.400 bps, non-transparent, USSD
FAX	Group 3: Class 1, Class 2
SIM interface	<ul style="list-style-type: none"> Supported SIM card: 3V External SIM card reader has to be connected via interface connector (note that card reader is not part of TC35i)
Antenna interface	50 Ohm antenna connector
Audio interface	Two analog audio interfaces (balanced microphone inputs and balanced outputs)
Speech codec	Triple rate codec: <ul style="list-style-type: none"> Half Rate (ETS 06.20) Full Rate (ETS 06.10) Enhanced Full Rate (ETS 06.50 / 06.60 / 06.80) Enhanced handsfree operation with echo cancellation and noise reduction
Serial interface	<ul style="list-style-type: none"> 2.65V level bi-directional bus for commands / data using AT commands Supports RTS/CTS hardware handshake and software XON/XOFF flow control. Multiplex ability according to GSM 07.10 Multiplexer protocol Baud rates from 300bps to 230.400 bps Autobauding supports baud rates: 1.200, 2.400, 4.800, 9.600, 19.200, 38.400, 57.600, 115.200 and 230.400 bps

Feature	Implementation
Phonebook management	Supported phonebook types: SM, FD, LD, MC, RC, ON, ME
SIM Application Toolkit	Supports SAT class 3, GSM 11.14 Release 98, support of letter class "c"
Ringing tones	Offers a choice of 7 different ringing tones / melodies, easily selectable with AT commands
Real time clock	Implemented
Timer function	Programmable via AT command
Physical characteristics	Size: 54.5 x 36.0 x 3.60 mm Weight: 9g
Evaluation kit	The DSB35 support box is an evaluation kit designed to test and type approve Siemens cellular engines and provide a sample configuration for application engineering. For ordering information see Chapter 8.

2.2 Circuit concept

Figure 1 shows a block diagram of the TC35i module and illustrates the major functional components:

GSM Baseband Block:

- GSM Controller operating at 26MHz
- Power supply ASIC
- Memory
- Application interface (ZIF connector)
- Charging circuit

GSM RF section:

- RT transceiver
- RF power amplifier
- RF fronted
- Antenna connector

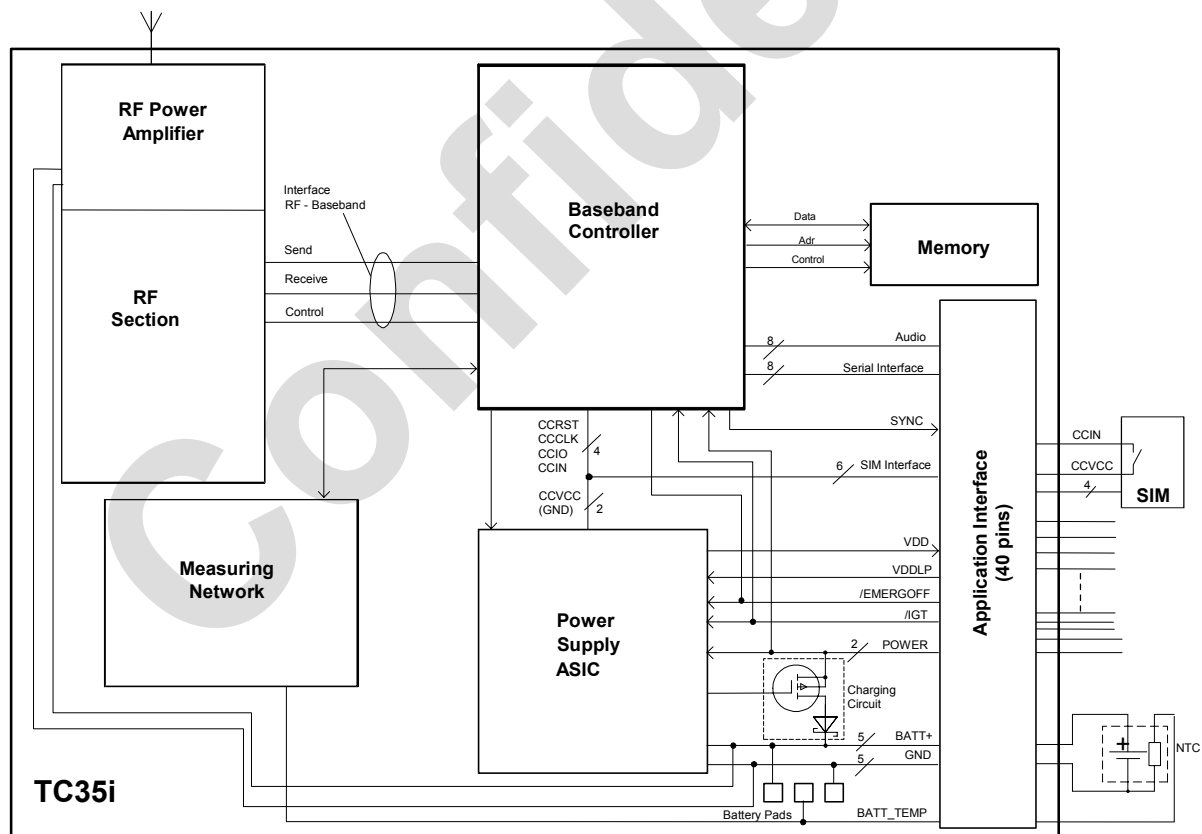

Figure 1: Block diagram of TC35i

3 Application Interface

TC35i is equipped with a 40-pin 0.5mm pitch ZIF connector that connects to the cellular application platform. The host interface incorporates several sub-interfaces described in the following chapters:

- Power supply and charging (see Chapters 3.2 and 3.3)
- Serial interface (see Chapter 3.6)
- Two audio interfaces (see Chapter 3.7)
- SIM interface (see Chapter 3.8)

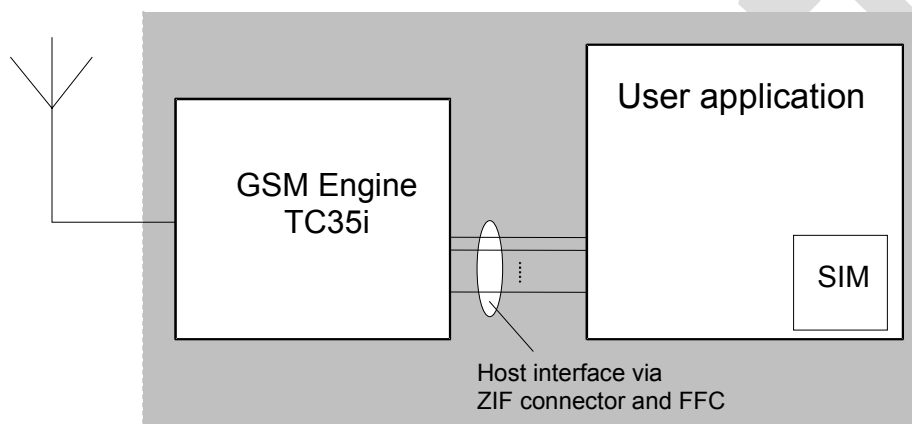

Figure 2: Block diagram of a cellular application

Electrical and mechanical characteristics of the ZIF connector are specified in Chapter 6.3. Ordering information for the ZIF connector and the required cables are listed in Chapter 8.

3.1 Operating modes

The table below briefly summarizes the various operating modes referred to in the following chapters.

Table 2: Overview of operating modes

Mode	Function
Normal operation	SLEEP Various power saving modes set with AT+CFUN command. Software is active to a minimum extent. If the module was registered to a GSM network in IDLE mode, it remains, in SLEEP mode, registered and pageable from the BTS. Power saving can be chosen at different levels. The NON_CYCLIC SLEEP mode (AT+CFUN=0) disables the AT interface. The CYCLIC SLEEP mode AT+CFUN=5, 6, 7 and 8 alternately activate and deactivate the AT interface to allow permanent access to all AT commands.
	IDLE Software is active. Once registered to the GSM network, paging with BTS is carried out. The engine is ready to send and receive.
	TALK Connection between two subscribers is in progress. Power consumption depends on network coverage individual settings, such as DTX off/on, FR/EFR/HR, hopping sequences, antenna.
Power Down	Normal shutdown after sending AT^SMSO command or emergency power off via /EMERGOFF pin. The Power Supply ASIC (PSU_ASIC) disconnects the supply voltage from the baseband part of the circuit. Only a voltage regulator in the PSU-ASIC is active for powering the RTC. Software is not active. The serial interface is not accessible. Operating voltage (connected to BATT+) remains applied
Alarm mode	Restricted operation launched by RTC alert function while GSM engine is in Power Down mode. GSM engine will not be registered to GSM network. Limited number of AT commands are accessible.
Charge-only mode	Limited operation for battery powered applications. Enables charging while engine is detached from GSM network. Limited number of AT commands is accessible. There are several ways to launch Charge-only mode: <ul style="list-style-type: none"> • From Power Down mode: Connect charger to POWER lines when engine was powered down by AT^SMSO. • From Normal mode: Connect charger to POWER lines, then enter AT^SMSO.
Charge mode during normal operation	Normal operation (SLEEP, IDLE, TALK, DATA) and charging running in parallel. Charge mode changes to Charge-only mode when GSM engine is powered down before charging has been completed.

See also Table 8 and Table 9 for the various options of waking up the GSM engine and proceeding from one mode to another.

3.2 Power supply

The power supply of the GSM engine has to be a single voltage source in the range of $V_{BATT+} = 3.3V \dots 4.8V$. It must be able to withstand a sufficient current in a transmission burst which typically rises to 2A. Beyond that, the power supply must be able to account for increased current consumption if the module is exposed to inappropriate conditions, for example antenna mismatch.

5 BATT+ pins and 5 GND pins are available on the ZIF connector. The RF power amplifier is driven directly from BATT+.

All the key functions for supplying power to the GSM engine are handled by an ASIC power supply. The ASIC provides the following features:

- Stabilizes the supply voltages for the GSM baseband processor and for the RF part using linear voltage regulators.
- Controls the module's power up and power down procedures.
- A watchdog logic implemented in the baseband processor periodically sends signals to the ASIC, allowing it to maintain the supply voltage for all TC35i components. Whenever the watchdog pulses fail to arrive constantly, the module is turned off.
- Delivers a regulated voltage of 2.9V across the VDD pin. The output voltage VDD may be used to supply your application, for example, an external LED or level shifter. However, the external circuitry must not cause any spikes or glitches on voltage VDD. This voltage is not available in POWER DOWN mode. Therefore, the VDD pin can be used to indicate whether or not TC35i is in POWER DOWN mode.
- Provides power to the SIM interface.

Please refer to Table 3 for a description of the power supply pins and their electrical specifications.

3.2.1 Power supply pins on the ZIF connector

10 pins of the ZIF connector are dedicated to connect the supply voltage (BATT+) and ground (GND). The values stated below must be measured directly at the reference points on the TC35i board (TP BATT+ and TP GND as shown in Figure 35)

The POWER pins serve as control signals for charging a Li-Ion battery. VDDL P can be used to back up the RTC.

Table 3: Power supply pins of ZIF connector

Signal name	Pin	I/O	Description	Parameter
BATT+	1-5	I/O	Positive operating voltage	3.3 V...4.8 V, $I_{tvd} \leq 2$ A during transmit burst The minimum operating voltage must not fall below 3.3 V, not even in case of voltage drop.
GND	6-10	X	Ground	0 V
POWER	11-12	I	Positive charging voltage	$I_{max} = 500$ mA (provided by external source, e.g. charger) $U = 5.5...8$ V recommended internal Pull Down $R=100k\Omega$
VDDL P	30	I/O	Buffering of RTC (see Chapter 3.3.1.4)	$U_{OUT,max} = V_{BATT+}$ $U_{IN} = 2.0$ V...5.5 V $R_i = 1k\Omega$ $I_{in,max} = 30\mu A$

3.2.2 Minimizing power losses

When designing the power supply for your application please pay specific attention to power losses. Ensure that the input voltage BATT+ never drops below 3.3 V on the TC35i board, not even in a transmit burst where current consumption can rise to typical peaks of 2A. Any voltage drops that may occur in a transmit burst should not exceed 400mV. Please note that TC35i switches off when exceeding these limits. For further details see Chapter 5.4.

Note: In order to minimize power losses, use a FFC cable as short as possible. The resistance of the power supply lines on the host board and a battery pack should also be considered.

Example: The ZIF-FFC-ZIF connection causes a resistance of 50mΩ in the BATT+ line and 50mΩ in the GND line, if the FFC reaches the maximum length of 200mm. As a result, a 2A transmit burst would add up to a total voltage drop of 200mV. In addition, if a battery pack is involved, further losses may occur due to the resistance across the battery lines.

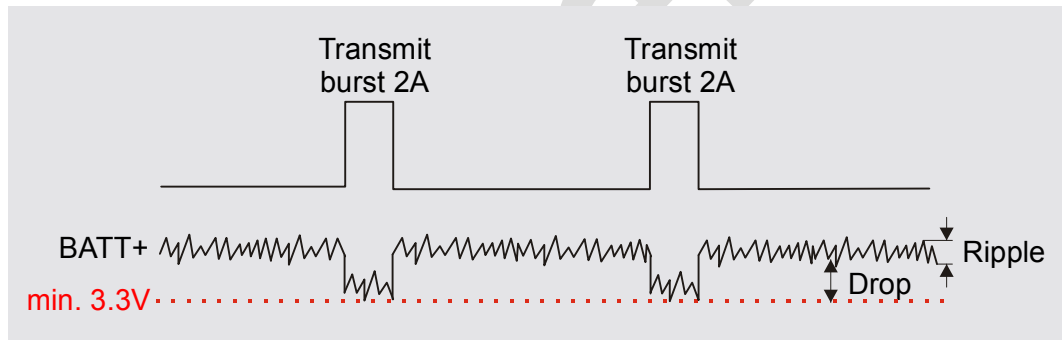

Figure 3: Power supply limits during transmit burst

The input voltage V_{BATT+} must be measured directly at the test points on the TC35i board. For detailed information see Figure 35.

3.2.3 Monitoring power supply

To help you monitor the supply voltage you can use the AT^SBV command which returns the voltage measured at TP BATT+ and GND.

The voltage is continuously measured at intervals depending on the operating mode on the RF interface. The duration of measuring ranges from 0.5s in TALK/DATA mode to 50s when TC35i is deregistered. The displayed voltage (in mV) is averaged over the last measuring period before the AT^SBV command was executed.

For details please refer to [1]

3.3 Power up / down scenarios

3.3.1 Turn on the GSM engine

Your TC35i GSM engine can be activated in a variety of ways which are described in the following chapters:

- via ignition line IGT: starts normal operating state (see Chapters 3.3.1.1 and 3.3.1.2)
- via POWER lines: starts charging algorithm (see Chapters 0 and 3.3.1.3)
- via RTC interrupt: starts Alarm mode (see Chapter 3.3.1.4)

3.3.1.1 Turn on GSM engine using the ignition line IGT (Power on)

To switch on TC35i the /IGT (Ignition) signal needs to be driven to ground level for at least 100ms. This can be accomplished using an open drain/collector driver in order to avoid current flowing into this pin.

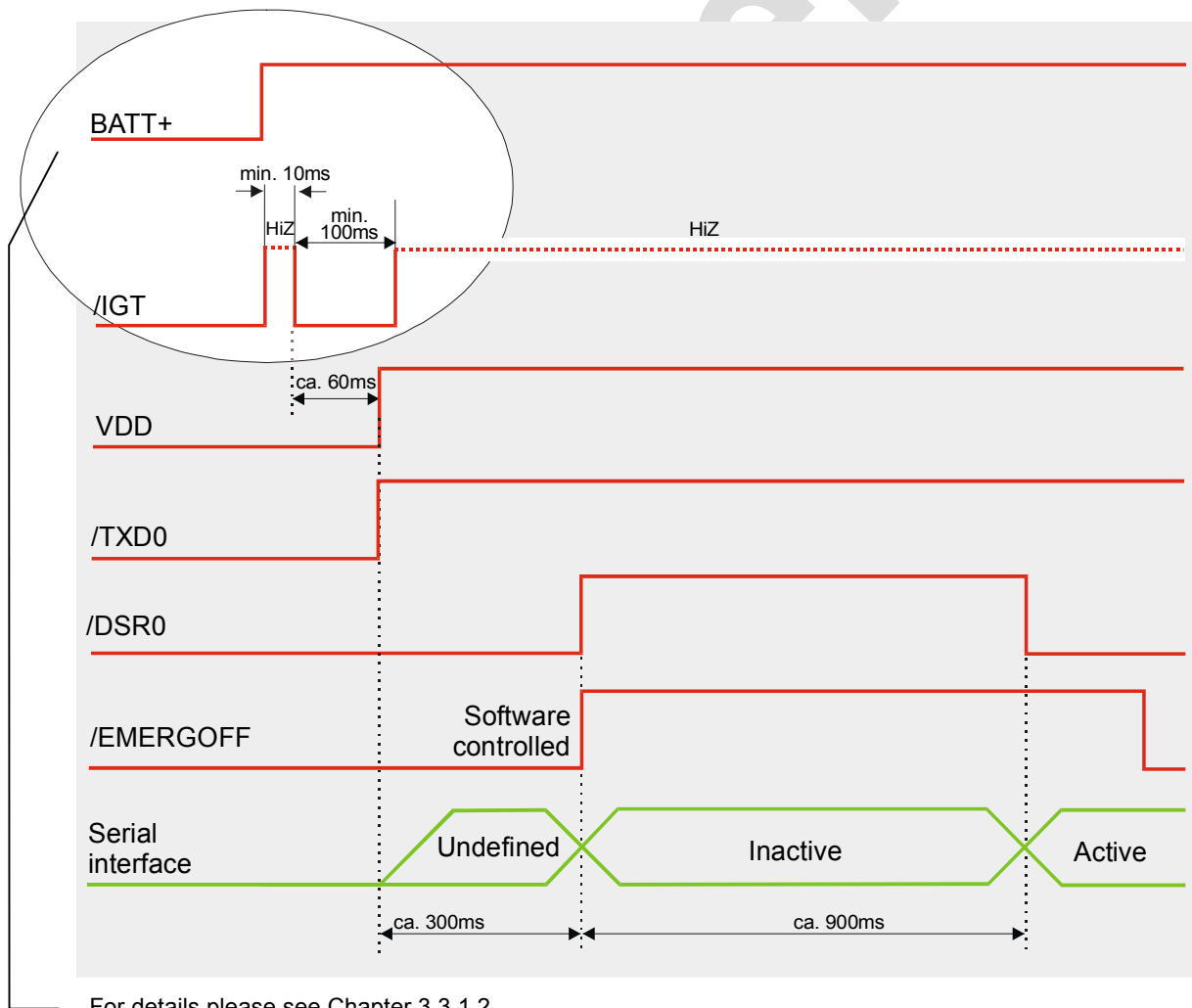

Figure 4: Power-on by ignition signal

In a battery operated TC35i application, the duration of the /IGT signal must be 1s minimum when the charger is connected and you may want to go from charging to Normal mode.

3.3.1.2 Timing of the ignition process

When designing your application platform take into account that powering up TC35i requires the following steps.

- The ignition line cannot be operated until V_{BATT+} passes the level of 3.0V.
- 10ms after V_{BATT+} has reached 3.0V the ignition line can be switched low. The duration of the falling edge must not exceed 1ms.
- Another 100ms are required to power up the module.
- Ensure that V_{BATT+} does not fall below 3.0V while the ignition line is driven. Otherwise the module cannot be activated. If the VDDL P line is fed from an external power supply, the /IGT line is HiZ before the rising edge of BATT+.
- If the VDDL P line is fed from an external power supply as explained in Chapter 3.5, the /IGT line is HiZ before the rising edge of BATT+.

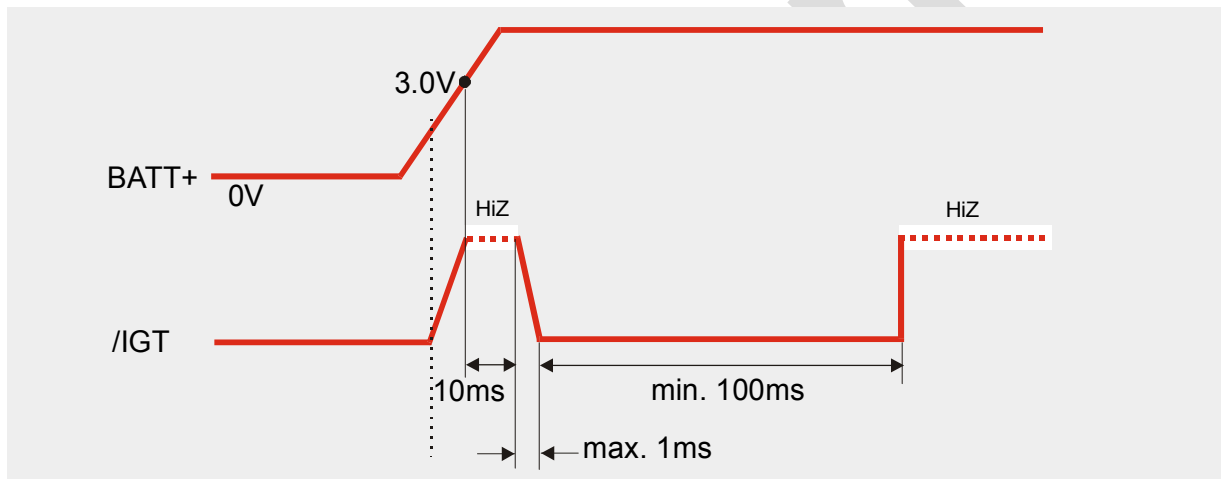

Figure 5: Timing of power-on process if VDDL P is not used

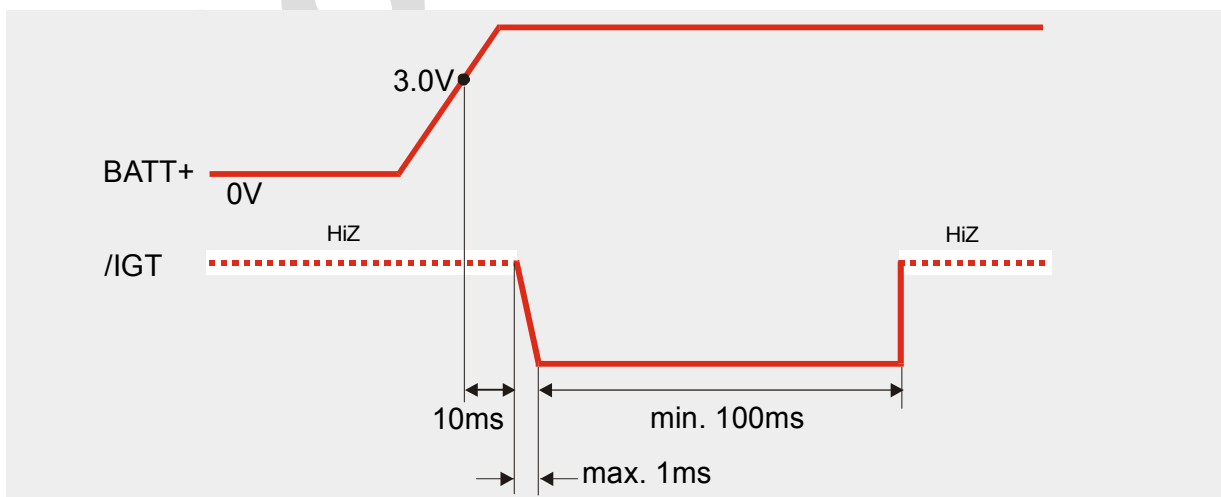

Figure 6: Timing of power-on process if VDDL P is fed from external source

3.3.1.3 Turn on GSM engine using the POWER lines

As detailed in Chapter 3.3.4.3, the charging adapter can be connected regardless of the GSM engine's operating mode (except for Alarm mode).

If the charger is connected to the POWER lines while the GSM engine is off, only the charging algorithm will be launched. TC35i enters a restricted mode, referred to as Charge-only mode where only the charging algorithm will be launched.

During the Charge-only mode the GSM engine is neither logged on to the GSM network nor is the serial interface fully accessible. When the minimum voltage of 3.2V is achieved within 60 minutes the charging process proceeds to software controlled charging. To switch to normal operation and log on to the GSM network, the IGT line needs to be activated.

3.3.1.4 Turn on GSM engine using the RTC (Alarm mode)

Another power-on approach is to use the RTC, which is constantly supplied with power from a separate voltage regulator in the power supply ASIC. The RTC provides an alert function which allows to wake TC35i while power is off. To prevent the engine from unintentionally logging into the GSM network, this procedure only enables restricted operation, referred to as Alarm mode. It must not be confused with a wake-up or alarm call that can be activated by using the same AT command, but without switching off power.

Use the *AT+CALA* command to set the alarm time. The RTC retains the alarm time if the GSM engine was powered down by *AT^SMSO*. Once the alarm is timed out and executed, TC35i enters into the Alarm mode. This is indicated by an Unsolicited Result Code (URC) which reads:

```
^SYSSTART ALARM MODE
```

In Alarm mode only a limited number of AT commands is available. For further instructions refer to the AT Command Set.

Table 4: AT commands available in Alarm mode

AT command	Use
AT+CALA	Set alarm time
AT+CCLK	Set date and time of RTC
AT^SBC	In Alarm mode, you can only query the present current consumption and check whether or not a charger is connected. The battery capacity is returned as 0, regardless of the actual voltage (since the values measured directly on the cell are not delivered to the module).
AT^SCTM	Query temperature of GSM engine
AT^SMSO	Power down GSM engine

For the GSM engine to change from the Alarm mode to full operation (normal operating mode) it is necessary to drive the ignition line to ground. This must be implemented in your host application as described in Chapter 3.3.1.1. If your application is battery powered note that charging cannot be started while the engine is in Alarm mode, i.e. charging will not begin even though the charger connects to the POWER lines. See also Chapter 3.4.6 which summarizes the various options of changing the mode of operation.

If your host application uses the SYNC pin to control a status LED as described in Chapter 3.9.2.2, please note that the LED is off while the GSM engine is in Alarm mode.

3.3.2 Turn off GSM engine

To switch the module off the following procedures may be used:

- *Normal procedure*: Software controlled by sending AT^SMSO command over the serial application interface. See Chapter 3.3.2.1.
- *Emergency shutdown*: Hardware driven by switching the /EMERGOFF line of the ZIF connector to ground = immediate shutdown of supply voltages, only applicable if the software controlled procedure fails! See Chapter 3.3.2.2.
- *Automatic shutdown*: Takes effect if undervoltage / overvoltage is detected or if battery or board (engine) temperature exceeds critical limit. See Chapter 3.3.3.

3.3.2.1 Turn off GSM engine using AT command

The best and safest approach to powering down TC35i is to issue the AT^SMSO command. This procedure lets the engine log off from the network and allows the software to enter into a secure state and to save data before disconnecting the power supply. Before switching off the device sends the result code

^SMSO: MS is OFF

In the resulted Power Down mode, no further AT command can be executed. However, the RTC is still active.

While TC35i is in POWER DOWN mode the application interface is switched off and must not be fed from any other source. Therefore, your application must be designed to avoid any current flow into any digital pins of the application interface. POWER DOWN is also signaled by the VDD pin, which in this mode, is off.

3.3.2.2 Emergency shutdown using /EMERGOFF pin

Caution: Use the /EMERGOFF pin only when, due to serious problems, the software is not responding for more than 5 seconds. Pulling the /EMERGOFF pin causes the loss of all information stored in the volatile memory since power is cut off immediately. Therefore, this procedure is intended only for use in case of emergency, e.g. if TC35i fails to shut down properly.

The /EMERGOFF signal is available on the ZIF connector. To control the /EMERGOFF line it is recommended to use an open drain / collector driver. To turn the GSM engine off, the /EMERGOFF line has to be driven to ground for ≥ 3.2 s.

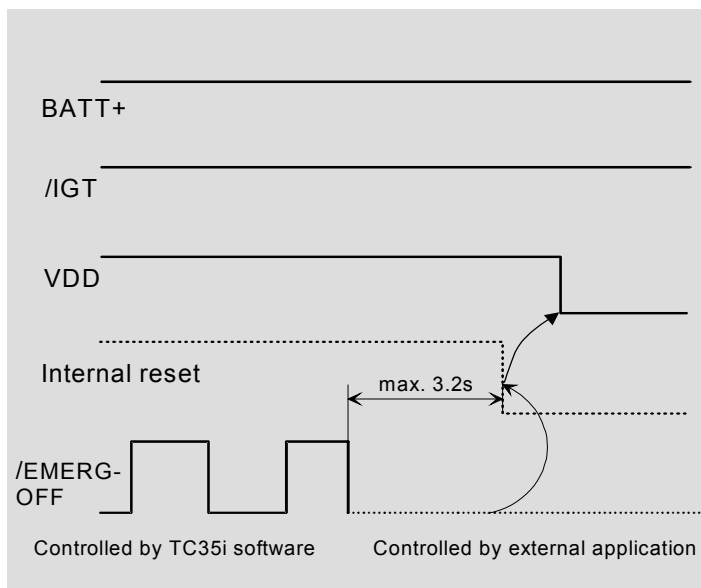

Figure 7: Deactivating GSM engine by Power Down signal

How does it work:

- Voltage V_{BATT+} is permanently applied to the module.
- The module is active while the internal reset signal is kept at high potential.

During operation, the baseband controller generates watchdog pulses at regular intervals.

When the /EMERGOFF pin is grounded these watchdog pulses are cut off from the power supply ASIC. The power supply ASIC shuts down the internal supply voltages of TC35i after max. 3.2s and the module turns off. Consequently the output voltage at VDD is switched off.

3.3.3 Automatic shutdown

Automatic shutdown takes effect if

- the TC35i board is exceeding the critical limits of overtemperature or undertemperature
- the battery is exceeding the critical limits of overtemperature or undertemperature.
- undervoltage is detected
- overvoltage is detected.

The automatic shutdown procedure is equivalent to the power-down initiated with the AT^SMSO command, i.e. TC35i logs off from the network and the software enters a secure state avoiding loss of data. When the module is in IDLE mode it takes typically one minute to deregister from the network and to switch off.

Alert messages transmitted before the device switches off are implemented as Unsolicited Result codes (URCs). For details see the following chapters and the description of the two commands AT^SCTM and AT^SBC provided in [1].

3.3.3.1 Temperature dependent shutdown

The board temperature is constantly monitored by an internal NTC resistor located on the PCB. The NTC that detects the battery temperature must be part of the battery pack circuit as described in Chapter 3.3.4. The values detected by either NTC resistor are measured directly on the board and the battery and, therefore, are not fully identical with the ambient temperature. For more detailed information please refer to Table 22.

Each time the board or battery temperature goes out of range or back to normal, TC35i instantly displays an alert (if enabled).

- URCs indicating the level "1" or "-1" allow the user to take appropriate precautions, such as protecting the module from exposure to extreme conditions. The presentation of the URCs depends on the settings selected with the AT^SCTM write command:
 - AT^SCTM=1: Presentation of URCs is always enabled.
 - AT^SCTM=0 (default): Presentation of URCs is enabled for 15 seconds time after start-up of TC35i. After 15 seconds operation, the presentation will be disabled, i.e. no alert messages can be generated.
- URCs indicating the level "2" or "-2" are instantly followed by an orderly shutdown. The presentation of these URCs is always enabled, i.e. they will be output even though the factory setting AT^SCTM=0 was never changed.

Table 5 summarizes the maximum ratings and the associated URCs.

Table 5: Temperature dependent behaviour

Sending temperature warning (15 s after TC35i start-up, otherwise only if URC presentation enabled)	
^SCTM_A: 1	Caution: T_{amb} of battery is between +56°C and +60°C.
^SCTM_B: 1	Caution: T_{amb} of board is between +55°C and +70°C.
^SCTM_A: -1	Caution: T_{amb} of battery is between -14°C and -18°C.
^SCTM_B: -1	Caution: T_{amb} of board is between -20°C and -25°C.
^SBCTM_A: 0	Battery back to uncritical temperature range.
^SBCTM_B: 0	Board back to uncritical temperature range.
Automatic shutdown (URC appears no matter whether presentation was enabled)	
^SCTM_A: 2	Alert: T_{amb} of battery $\geq 60^\circ\text{C}$. TC35i switches off.
^SCTM_B: 2	Alert: T_{amb} of board $\geq 70^\circ\text{C}$. TC35i switches off.
^SCTM_A: -2	Alert: T_{amb} of battery $< -18^\circ\text{C}$. TC35i switches off.
^SCTM_B: -2	Alert: T_{amb} of board $\leq -25^\circ\text{C}$. TC35i switches off.

The values stated in Table 5 are based on test conditions according to IEC 60068-2-2 (still air).

3.3.3.2 Temperature control during emergency call

If the temperature limit is exceeded while an emergency call is in progress the engine continues to measure the temperature and to deliver alert messages, but deactivates the shutdown functionality.

Once the call is terminated the temperature control will be resumed. If the temperature is still out of range TC35i switches off immediately.

3.3.3.3 Monitoring the board temperature of TC35i

The AT^SCTM command can also be used to check the present status of the board. Depending on the selected mode, the read command returns the current board temperature in degrees Celsius or only a value that indicates whether the board is within the safe or critical temperature range. See [1] for further instructions.

3.3.3.4 Shutdown in the event of undervoltage

Undervoltage protection is the same, regardless of whether or not an NTC connects to the BATT_TEMP terminal as described in Chapter 3.3.4.2. This means, it makes no difference whether the application is battery powered or operated from a fixed supply voltage.

Whenever the supply voltage falls below the specified value (see Table 24) TC35i will automatically send the URC

^SBC: Undervoltage

The message will be reported, for example, when the user attempts to set up a call while the voltage is close to the critical limit and further power loss may be expected during a transmit burst. To remind the user that the battery needs to be charged soon, the URC appears several times in a minute before the module performs an orderly shutdown.

If the voltage drops quickly down to a value which is 50mV below the minimum threshold, then only one URC will be presented.

This type of URC does not need to be activated by the user. It will be output automatically when fault conditions occur.

3.3.3.5 Shutdown in the event of overvoltage

Overvoltage warning and shutdown thresholds depend on a variety of factors. The major difference is whether the application is operated from a battery or a fixed supply voltage. There are two types of overvoltage URCs available that may be reported as explained below:

^SBC: Overvoltage warning

This URC type is only intended for applications which are operated from a fixed supply source (= no NTC connected to the BATT_TEMP terminal). It is an alarm indicator displayed if the voltage reaches the specified maximum value (see Table 24). The URC appears only once.

^SBC: Overvoltage shutdown

- If the application is operated from a fixed supply source (= no NTC connected to the BATT_TEMP terminal): In the event of the voltage rising above the maximum voltage (see Table 24) the module sends one URC and then performs an orderly shutdown.
- If the application is battery powered and, thus, the presence of an NTC is detected at BATT_TEMP: The shutdown threshold is determined primarily by the overcharge detection voltage of the battery pack which is $4.3V \pm TBD$ for the recommended battery (see Table 6). In the event of the voltage exceeding this threshold the module sends one URC and then performs an orderly shutdown. The same applies if, due to an error caused by a bad battery, charging is not properly terminated and overcharging needs to be prevented.

This type of URC does not need to be activated by the user. It will be output automatically when fault conditions occur.

3.3.4 Battery pack

For some applications the use of a battery pack may be required. TC35i can be powered from a Li-Ion battery pack which must be specified for a typical nominal voltage of 3.6 V and a maximum charging voltage of 4.2 V. The recommended capacity may be at least 600mAh.

It is strongly recommended that the battery pack you want to integrate into your TC35i application is compliant with these specifications. This ensures reliable operation, proper charging and, particularly, allows you to monitor the battery capacity using the AT^SBC command (see [1] for details). A battery pack especially designed to operate with TC35i is specified in Chapter 3.3.4.1.

- Since charging and discharging largely depend on the battery temperature, the battery pack should include an NTC resistor. If the NTC is not inside the battery it must be in thermal contact with the battery. The NTC resistor must be connected between BATT_TEMP and GND. Required NTC characteristics are: $10\text{k}\Omega \pm 5\% @ 25^\circ\text{C}$, $B(25/85)=3435\text{K} \pm 3\%$ (alternatively acceptable: $10\text{ k}\Omega \pm 2\% @ 25^\circ\text{C}$, $B_{25/50} = 3370\text{K} \pm 3\%$). Please note that the NTC is indispensable for proper charging, i.e. the charging process will not start if no NTC is present.
- Ensure that the pack incorporates a protection circuit capable of detecting overvoltage (protection against overcharging), undervoltage (protection against deep discharging) and overcurrent. The circuit must be insensitive to pulsed current.
- On the TC35i module, a built-in measuring circuit constantly monitors the battery voltage. In the event of undervoltage, the module performs an orderly shutdown. Undervoltage thresholds are specific to the battery pack and must be evaluated for the intended model. When you evaluate undervoltage thresholds, consider both the current consumption of TC35i and of the application circuit.
- The internal resistance of the battery and the protection should be as low as possible. It is recommended not to exceed $150\text{m}\Omega$, even in extreme conditions at low temperature.
- The battery cell must be insensitive to rupture, fire and gasing under extreme conditions of temperature and charging (voltage, current).
- The battery pack must be protected from reverse pole connection. For example, the casing should be designed to prevent the user from mounting the battery in reverse orientation.
- The battery pack must be approved to satisfy the requirements of CE conformity.

Figure 8 shows the circuit diagram of a typical battery pack design that includes the protection elements described above.

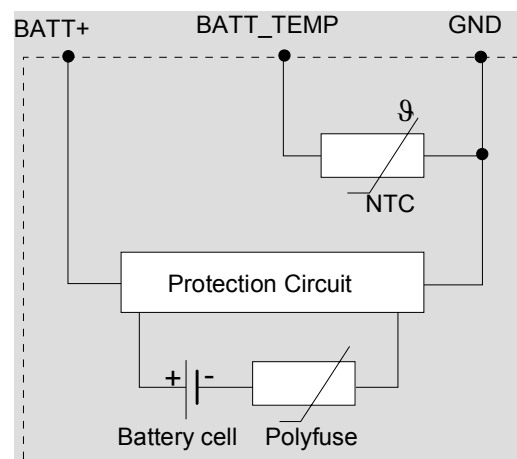

Figure 8: Battery pack circuit diagram

3.3.4.1 Recommended battery pack

The following battery pack has been especially designed to operate with TC35i modules.

Table 6: Specifications of XWODA battery pack

Product name, type	XWODA, Li-Ion, 3.6V, 850mAh
Vendor To place orders or obtain more information please contact:	Shenzhen Xwoda Electronic Co., Ltd Building C, Tongfukang Industrial Zone Shiyan Town Bao'an District Shenzhen P.R.China Contact: Wiachrad Tsui Phone: +86-755-27623789 ext. 370 Fax: +86-755-27623078 Email: waichard@xwoda.com.cn
Nominal voltage	3.6V
Capacity	850mAh
NTC	10kΩ ± 5% @ 25°C, B (25/85)=3435K ± 3%
Overcharge detection voltage	4.325 ± 0.025V
Overcharge release voltage	4.075 ± 0.025V
Overdischarge detection voltage	2.5 ± 0.05V
Overdischarge release voltage	2.9 ± 0.5V
Overcurrent detection	3 ± 0.5A
Nominal working current	<5μA
Current of low voltage detection	0.5μA
Overcurrent detection delay time	8~16ms
Short detection delay time	50μs
Overdischarge detection delay time	31~125ms
Overcharge detection delay time	1s
Internal resistance	<130mΩ

3.3.4.2 Implemented charging technique

Charging can be accomplished in a temperature range from 0°C to +45°C. The charging process supports trickle charging and processor controlled fast charging. The trickle charge current passes the 470Ω resistor path as shown in Figure 9.

For this solution, the fast charging current provided by the charger or any other external source must be limited to 500mA.

Trickle charging

- Trickle charging starts when the charger is connected to the POWER pins and if the battery is deeply discharged (<3.2V). In trickle mode, the battery is charged with a current of less than 10mA.
- Trickle charging stops when the battery voltage reaches 3.6V.

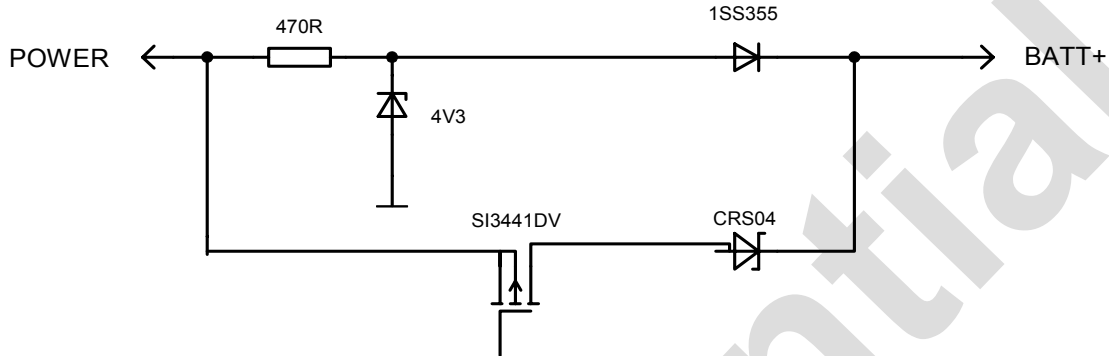

Figure 9: Internal charging circuit

Fast charging

- After trickle charging has raised the battery voltage to 3.2V within 60 minutes $\pm 10\%$ from connecting the charger, the power ASIC turns on and wakes up the baseband processor. Now, processor controlled fast charging begins. If the battery voltage was already above 3.2V, processor controlled fast charging starts just after the charger was connected to the POWER pins. Please note that the fast charging current passes the SI3441 transistor path, see Figure 9. If TC35i was in POWER DOWN mode, it turns on and enters the Charge-only mode along with fast charging (see also Chapter 3.3.1.3.). Fast charging delivers a constant current until the battery voltage reaches 4.2V and then proceeds with varying charge pulses. As shown in Figure 10, the pulse duty cycle is reduced to adjust the charging procedure and prevent the voltage from overshooting beyond 4.2V. Once the pulse width reaches the minimum of 100ms and the duty cycle does not change for 2 minutes, fast charging is completed.
- Fast charging can only be accomplished in a temperature range from 0°C to +45°C.

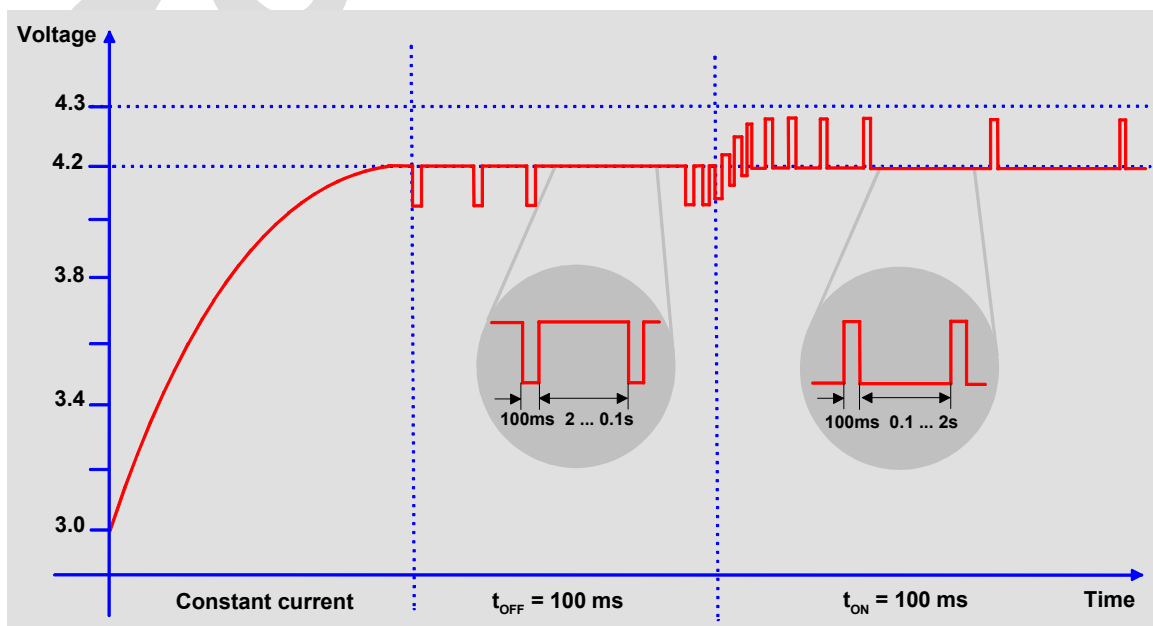

Figure 10: Charging process

Note: Do not connect the charger to the BATT+ lines. Only the POWER lines are intended as input for charging! The battery manufacturer must guarantee that the battery complies with the described charging technique

Please keep in mind that if trickle charging fails to raise the battery voltage to 3.2V within 60 minutes \pm 10%, processor controlled charging does not begin. If the voltage is still below 3.2V the internal timer switches off. Shortly disconnecting and reconnecting the charger restarts the timer and the entire charging process.

Apart from this, trickle charging continues whenever the charger connects to the POWER lines.

3.3.4.3 Operating modes during charging

Of course, the battery can be charged regardless of the engine's operating mode. When the GSM engine is in Normal mode (SLEEP, IDLE or TALK mode), it remains operational while charging is in progress (provided that sufficient voltage is applied). The charging process during the Normal mode is referred to as *Charge mode*.

If the charger is connected to the POWER lines while the engine is in Power Down mode (caused by AT^SMSO), the GSM engine goes into *Charge-only mode*.

	How to activate mode	Advantages
Charge mode	Connecting charger to the POWER lines of TC35i while TC35i engine is operating, e.g. <ul style="list-style-type: none"> in IDLE or TALK mode in SLEEP mode 	<ul style="list-style-type: none"> Battery can be charged while GSM engine remains operational and registered to the GSM network. In IDLE and TALK mode, the serial interface is accessible. AT command set can be used to full extent. In NON-CYCLIC SLEEP mode, the serial interface is not accessible at all. During the CYCLIC SLEEP mode it can be used as described in Chapter 3.4.2
Charge-only mode	Connecting charger to the POWER lines while GSM engine is <ul style="list-style-type: none"> in Power Down mode (e.g. powered down by AT^SMSO) in Normal mode: Connect charger to POWER lines, then enter AT^SMSO. If VBATT+ < 3.0V the module does not automatically go into Charge-only mode. In this case, it is necessary to activate IGT for at least 100ms. If VBATT+ > 3.0V, Charge-only mode starts up without the need to activate IGT. <p>IMPORTANT: While trickle charging is in progress, be sure that the application is switched off. If the application is fed from the trickle charge current the module might be prevented from proceeding to software controlled charging since the current would not be sufficient.</p>	<ul style="list-style-type: none"> Battery can be charged while GSM engine is deregistered from GSM network. Charging runs smoothly due to constant current consumption. The AT interface is accessible and allows to use the commands listed below.

Features of the Charge-only mode

Once the GSM engine enters the Charge-only mode, the AT command interface presents an Unsolicited Result Code which reads:

```
^SYSSTART CHARGE-ONLY MODE
```

Note that this URC will not appear when autobauding was activated (due to the missing synchronization between DTE and DCE upon start-up). Therefore, it is recommended to select a fixed baudrate before using the Charge-only mode.

While the Charge-only mode is in progress, you can take advantage of the AT commands listed in Table 7. For further instructions refer to [1].

Table 7: AT commands available in Charge-only mode

AT command	Use
AT+CALA	Set alarm time
AT+CCLK	Set date and time of RTC
AT^SBC	Monitor charging process Note: While charging is in progress, no battery parameters are available. To query the battery capacity disconnect the charger. If the charger connects <i>externally</i> to the host device no charging parameters are transferred to the module. In this case, the command cannot be used.
AT^SCTM	Query temperature of GSM engine
AT^SMSO	Power down GSM engine

To proceed from Charge-only mode to normal operation, it is necessary to drive the ignition line to ground. This must be implemented in your host application as described in Chapter 3.3.1.1. When the engine is in Alarm mode there is no direct way to start charging, i.e. charging will not begin even though the charger connects to the POWER lines. See also Chapter 3.4.6 which summarizes the various options of changing the mode of operation. If your host application uses the SYNC pin to control a status LED as described in Chapter 3.9.2.2, please note that the LED is off while the GSM engine is in Charge-only mode.

3.3.4.4 Charger requirements

The charger must be designed to meet the following requirements:

a) Simple transformer power plug

- Output voltage: 5.5V...8V (under load)
- The charge current must be limited to 500mA
- Voltage spikes that may occur while you connect or disconnect the charger must be limited to a maximum of 15V and must not exceed 1ms
- There must not be any capacitor on the secondary side of the power plug (avoidance of current spikes at the beginning of charging)

b) Supplementary requirements for a) to ensure a regulated power supply

- When current is switched off a voltage peak of 10V is allowed for a maximum 1ms
- When current is switched on a spike of 1.6A for 1ms is allowed

Note: To detect extreme thermal conditions while charging is in progress, connect an NTC (10kΩ @ 25°C, B=3435 Kelvin ±3%) from BATT_TEMP to GND.

3.4 Power saving

SLEEP mode reduces the functionality of the TC35i module to a minimum and, thus, minimizes the current consumption to the lowest level. SLEEP mode is set with the AT+CFUN command which provides the choice of the functionality levels <fun>=0, 1, 5, 6, 7 or 8, all explained below. Further instructions of how to use AT+CFUN can be found in [1].

IMPORTANT: The AT+CFUN command can be executed before or after entering PIN1. Nevertheless, please keep in mind *that power saving works only while the module is registered to the GSM network*. If you attempt to activate power saving while the module is detached, the selected <fun> level will be set, though power saving does not take effect.

To check whether power saving is on, you can query the status of AT+CFUN if you have chosen CYCLIC SLEEP mode. If available, you can take advantage of the status LED controlled by the SYNC pin. The LED stops flashing once the module starts power saving.

The wake-up procedures are quite different depending on the selected SLEEP mode. Table 8 compares the wake-up events that can occur in NON-CYCLIC SLEEP mode and in the four CYCLIC SLEEP modes.

3.4.1 No power saving (AT+CFUN=1)

The functionality level <fun>=1 is where power saving is switched off. This is the default after startup.

3.4.2 NON-CYCLIC SLEEP mode (AT+CFUN=0)

If level 0 has been selected (AT+CFUN=0), the serial interface is blocked. The module shortly deactivates power saving to listen to a paging message sent from the base station and then immediately resumes power saving. Level 0 is called NON-CYCLIC SLEEP mode, since the serial interface is not alternatingly made accessible as in CYCLIC SLEEP mode.

The first wake-up event fully activates the module, enables the serial interface and terminates the power saving mode. In short, it takes TC35i back to the highest level of functionality <fun>=1.

3.4.3 CYCLIC SLEEP mode (AT+CFUN=5, 6, 7 and 8)

The functionality levels AT+CFUN=5, AT+CFUN=6, AT+CFUN=7 and AT+CFUN=8 are referred to as CYCLIC SLEEP modes. The major benefit over the NON-CYCLIC SLEEP mode is that the serial interface is not permanently blocked and that packet switched calls may go on without terminating the selected CYCLIC SLEEP mode. This allows TC35i to become active, for example to perform a data transfer, and to resume power saving after the data transfer is completed.

The CYCLIC SLEEP modes, give you greater flexibility regarding the wake-up procedures: For example, in all CYCLIC SLEEP modes, you can enter AT+CFUN=1 to permanently wake up the module. The best choice is using CFUN=7 or 8, since in these modes TC35i automatically resumes power saving, after you have sent or received a short message or made a call. CFUN=5 and 6 do not offer this feature, and therefore, are only supported for compatibility with earlier releases. Please refer to Table 8 for a summary of all modes.

The CYCLIC SLEEP mode is a dynamic process which alternatingly enables and disables the serial interface. The application must be configured to use hardware flow control for communication with the module (RTS/CTS handshake). By setting/resetting the /CTS signal, the module indicates to the application when the UART is active. The application must wait until /CTS is set (i.e. is active low) before data can be sent to the module.

The module starts or resumes power saving two seconds (AT+CFUN=5 or AT+CFUN=7) or ten minutes (AT+CFUN=6 or AT+CFUN=8) after the last character was sent or received. It resets the /CTS signal, and after additional 5ms, deactivates the UART to save power. See Figure 12 for more details.

3.4.4 Timing of the /CTS signal in CYCLIC SLEEP modes

The /CTS signal is enabled in synchrony with the module's paging cycle. It goes active low each time when the module starts listening to a paging message block from the base station. The timing of the paging cycle varies with the base station and can be determined by the following formula:

$$4.615 \text{ ms (TDMA frame duration)} * 51 \text{ (number of frames)} * \text{DRX value.}$$

DRX (Discontinuous Reception) is a value from 2 to 9, resulting in paging intervals from 0.47 to 2.12 seconds. The DRX value of the base station is assigned by the network operator.

If $\text{DRX} \geq 3$, i.e. if paging is performed at intervals from 0.71 to 2.12 seconds, each listening period causes the /CTS signal to go active low. If DRX is 2, i.e. if paging is done every 0.47 seconds, the /CTS signal is activated with every 2nd listening period.

The /CTS signal stays active low for 20 ms. This is followed by another 5 ms UART activity. Thus, once the /CTS signal goes active low, you have 25 ms to enter characters. In the pauses between listening to paging messages, while /CTS is high, the module resumes power saving and the AT interface is not accessible. See Figure 11

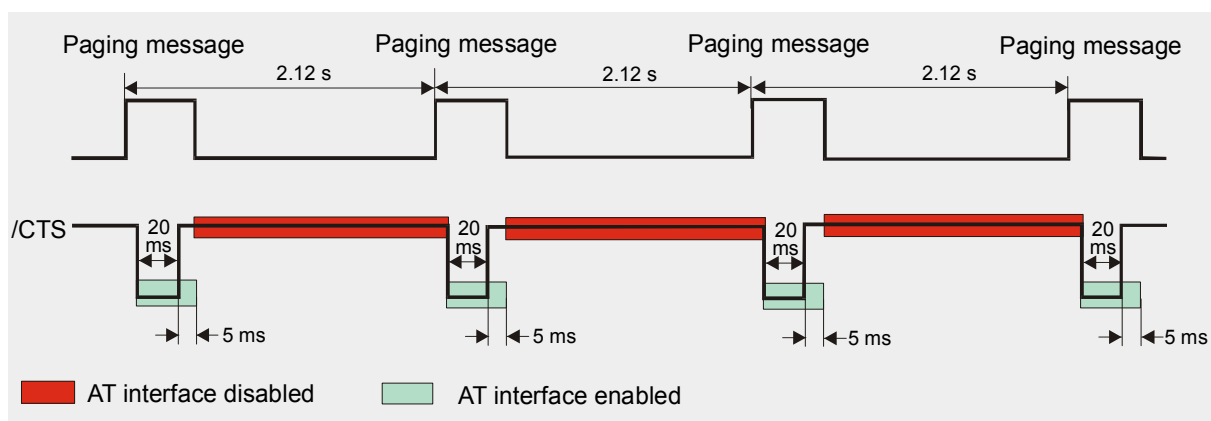

Figure 11: Timing of /CTS signal (example for a 2.12 s paging cycle)

Figure 12 illustrates the CFUN=5 mode, which resets the /CTS signal 2 seconds after the last character was sent or received. The UART is kept active for another 5 ms before power saving begins.

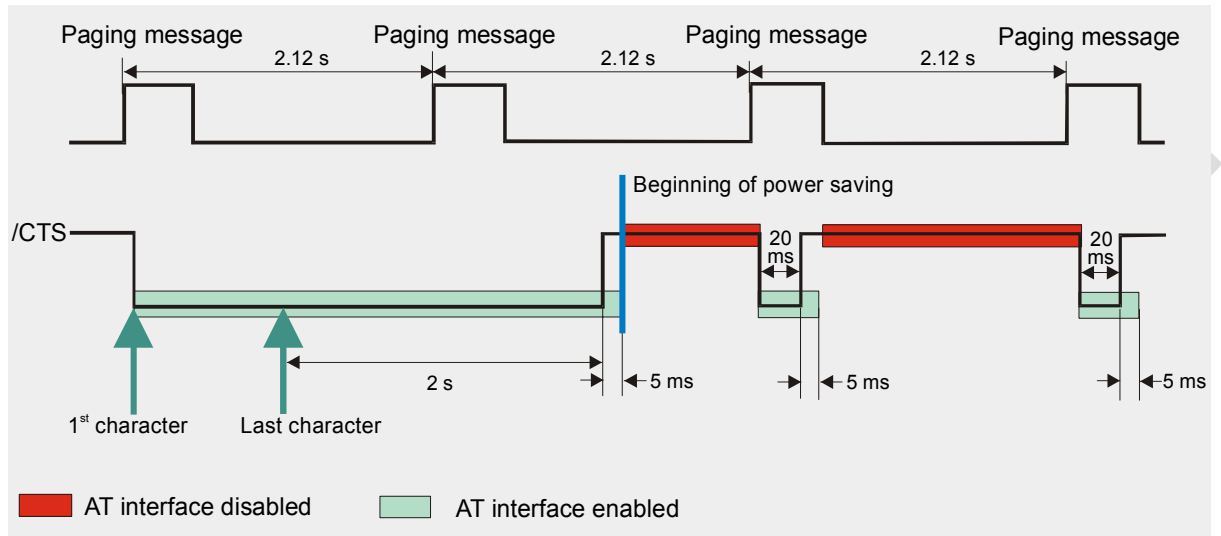

Figure 12: Beginning of power saving if CFUN=5

3.4.5 Wake up TC35i from SLEEP mode

A wake up event is any event that switches off the SLEEP mode and causes TC35i to return to full functionality. In short, it takes TC35i back to AT+CFUN=1.

Definitions of the state transitions described in Table 8:

Yes = TC35i exits SLEEP mode.

No = TC35i does not exit SLEEP mode.

Table 8: Wake-up events in NON-CYCLIC and CYCLIC SLEEP modes

Event	From SLEEP mode AT+CFUN=0 to AT+CFUN=1	From SLEEP mode AT+CFUN=5 or 6 to AT+CFUN=1	From SLEEP mode AT+CFUN=7 or 8 to AT+CFUN=1
Ignition line	No	No	No
/RTS0 or /RTS1 (falling edge)	Yes	No	No
Unsolicited Result Code (URC)	Yes	Yes	No
Incoming voice or data call	Yes	Yes	No
Any AT command (incl. outgoing voice or data call, outgoing SMS)	Not possible (UART disabled)	No	No
Incoming SMS depending on mode selected by AT+CNMI: AT+CNMI=0,0 (= default, no indication of received SMS)	No	No	No
AT+CNMI=1,1 (= displays URC upon receipt of SMS)	Yes	Yes	No
RTC alarm	Yes	Yes	No
AT+CFUN=1	Not possible (UART disabled)	Yes	Yes

Recommendation:

- In NON-CYCLIC SLEEP mode, you can set an RTC alarm to wake up TC35i and return to full functionality. This is a useful approach because, in this mode, the AT interface is not accessible.

3.4.6 Summary of state transitions (except SLEEP mode)

Table 9: State transitions of TC35i (except SLEEP mode)

The table shows how to proceed from one mode to another (gray column = present mode, white columns = intended modes)

Further mode →→→	Power Down	Normal mode ^{**)}	Charge-only mode ^{*)}	Charging in normal mode ^{**)*)}	Alarm mode
Present mode					
Power Down mode <u>without</u> charger	---	/IGT >100 ms at low level	Connect charger to POWER (high level at POWER)	No direct transition, but via "Charge-only mode" or "Normal mode"	Wake-up from Power Down mode (if activated with AT+CALA)
Power Down mode with charger (high level at POWER pins)	---	/IGT > 1 s at low level, if battery is fully charged	100ms < /IGT < 500ms at low level	/IGT >1 s at low level	Wake-up from Power Down mode (if activated with AT+CALA)
Normal mode ^{**)}	AT^SMSO or exceptionally /EMERGOFF pin > 3.2 s at low level	---	No automatic transition, but via "Power Down"	Connect charger to POWER (high level at POWER)	AT+CALA followed by AT^SMSO. TC35i enters Alarm mode when specified time is reached.
Charge-only mode ^{*)}	Disconnect charger (POWER at low level) or AT^SMSO or exceptionally /EMERGOFF >3.2 s at low level	No automatic transition, but via "Charge in Normal mode"	---	/IGT >1 s at low level	No direct transition
Charging in normal mode ^{**)*)}	Via "Charge-only mode" or exceptionally /EMERGOFF > 3.2 s at low level	Disconnect charger from POWER pins at TC35i	AT^SMSO	---	No direct transition
Alarm mode	AT^SMSO or exceptionally /EMERGOFF > 3.2 s at low level	/IGT >100 ms at low level	No transition	/IGT >100 ms at low level	---

^{*)} See Chapter 3.3.4.2 for details on the charging mode

^{**)} Normal mode covers TALK, IDLE and SLEEP modes

3.5 RTC backup

The internal Real Time Clock of TC35i is supplied from a dedicated voltage regulator in the power supply ASIC which is also active when TC35i is in POWER DOWN status. An alarm function is included that allows to wake up TC35i without logging on to the GSM network.

In addition, you can use the VDDL P pin on the ZIF connector (pin no. 30) to backup the RTC from an external capacitor or a battery (chargeable or non-chargeable). The capacitor is charged by the BATT+ line of TC35i. If the voltage supply at BATT+ is disconnected the RTC can be powered by the capacitor. The size of the capacitor determines the duration of buffering when no voltage is applied to the module, i.e. the greater capacitor the longer TC35i will save the date and time.

If you need to adjust the date and time use the AT+CCLK command. To set the alarm time enter AT+CALA. For further instructions please refer to Chapter 3.3.1.4 and to the AT Command Set.

A serial resistor placed on the board next to the VDDL P line limits the input current of an empty capacitor. This eliminates the need of adding a resistor as required in applications based on the earlier TC35 module.

The following figures show various sample configurations. The voltage applied at VDDL P can be in the range from 2 to 5.5V. Please refer to Table 23 for the parameters required.

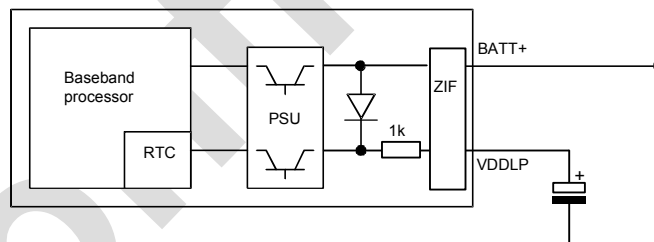

Figure 13: RTC supply from capacitor

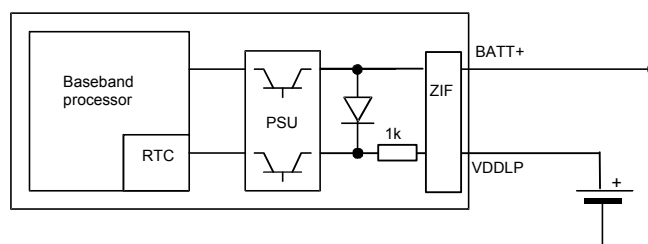

Figure 14: RTC supply from rechargeable battery

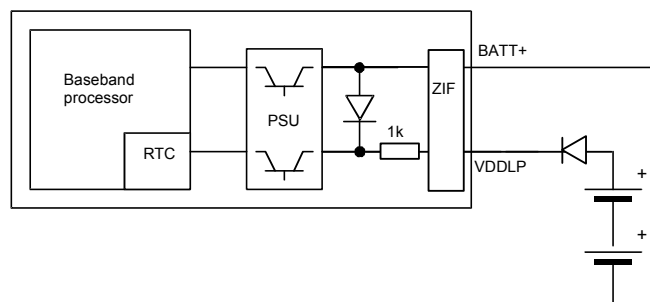

Figure 15: RTC supply from non-chargeable battery (e.g. a coin cell)

Note: In battery powered applications (Figure 14 and Figure 15), ensure that the voltage supplied from the batteries is $V_{BATTERY} \leq V_{BATT+}$.

The VDDL_P voltage should be kept below the minimum BATT+ voltage. This is significant to prevent the GSM engine from being powered over the RTC backup battery. Please refer to Chapter 5.3. for more information.

The reference voltage listed in Table 23 are values measured directly on the TC35i GSM engine. They do not apply to the accessories connected.

3.6 Serial interface

TC35i offers an 8-wire, unbalanced, asynchronous serial interface conforming to ITU-T V.24 protocol DCE signaling. The electrical characteristics do not comply with ITU-T V.28. The significant levels are 0V (for low data bit or ON condition) and 2.65V (for high data bit or OFF condition). For electrical characteristics please refer to Table 23.

TC35i is designed for use as a DCE. Based on the conventions for DCE-DTE connections it communicates with the customer application (DTE) using the following signals:

- Port /TXD @ application sends data to the module's /TXD0 signal line
- Port /RXD @ application receives data from the module's /RXD0 signal line

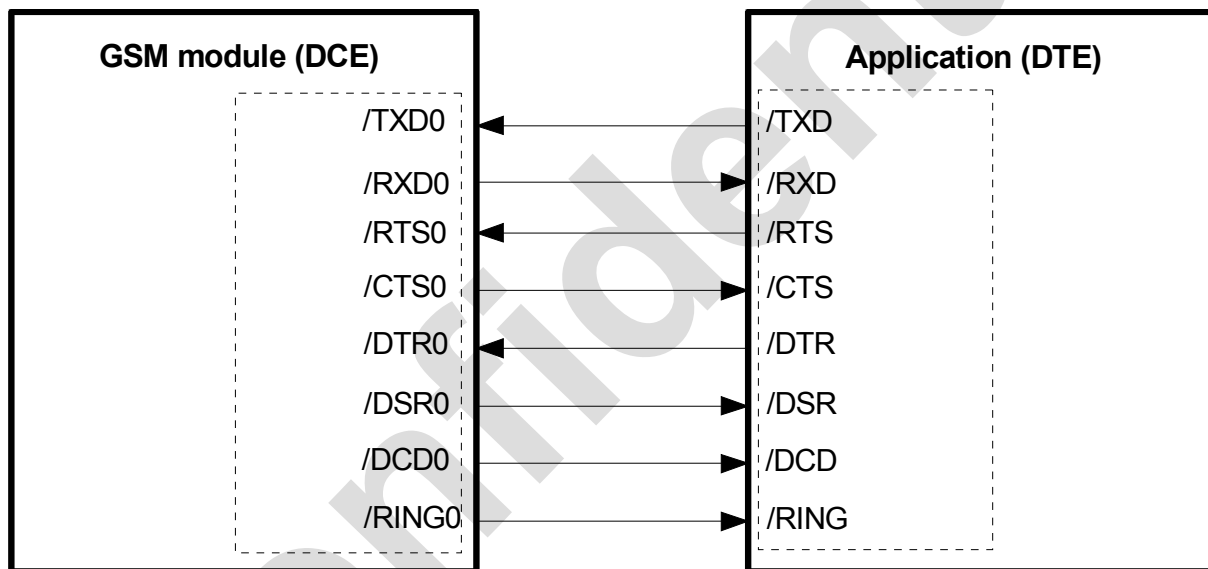

Figure 16: Serial interface

Table 10: DCE-DTE wiring

V.24 circuit	DCE		DTE	
	Pin function	Signal direction	Pin function	Signal direction
103	/TXD0	Input	/TXD	Output
104	/RXD0	Output	/RXD	Input
105	/RTS0	Input	/RTS	Output
106	/CTS0	Output	/CTS	Input
108/2	/DTR0	Input	/DTR	Output
107	/DSR0	Output	/DSR	Input
109	/DCD0	Output	/DCD	Input
125	/RING0	Output	/RING	Input

C O N F I D E N T I A L

The data interface is configured for 8 data bits, no parity and 1 stop bit, and can be operated at bitrates from 300 bps to 230.400 bps. Autobauding supports bit rates from 1.200 bps to 230.400 bps. Hardware handshake using the RTS0 / CTS0 signals and XON/XOFF software flow control are supported.

In addition, the modem control signals DTR^{*)}, DSR0, DCD0 and RING0 are available. The modem control signal RING0 (Ring Indication) can be used to indicate, to the cellular device application, that a call or Unsolicited Result Code (URC) is received. There are different modes of operation, which can be set with AT commands.

- ^{*)} **The DTR0 signal will only be polled once per second from the internal firmware of TC35i.**

3.7 Audio interface

TC35i comprises two analog audio interfaces, each with a balanced analog microphone input and a balanced analog earpiece output.

To suit several types of equipment, there are six audio modes available which can be selected with the AT^SNFS command. The electrical characteristics of the voiceband part vary with the audio mode. For example, sending and receiving amplification, sidetone paths, noise suppression etc. depend on the selected mode and can be set with AT commands (except for mode 1).

Please refer to Chapter 5.5 for specifications of the audio interface and an overview of the audio parameters. Detailed instructions on using AT commands are presented in [1]. Table 26 summarizes the characteristics of the various audio modes and shows what parameters are supported in each mode.

The first audio interface can be set to the audio modes 1 (default), 4 and 5. The default configuration is optimized for the Votronic HH-SI-30.3/V1.1/0 handset and used for type approving the Siemens reference configuration. Audio mode 1 has fix parameters which cannot be modified. In audio mode 4, you can avail of AT commands to adjust the Votronic handset as well as any individual handset.

The second audio interface is especially intended for headsets and can be configured to the audio modes 2, 3 or 6. In order to integrate a handsfree application you can take advantage of the Siemens Car Kit Portable and connect it to the second interface.

All microphone inputs and the earpiece / headset outputs are balanced. A power supply for electret microphones is implemented and can be used with in audio modes 1 to 4. If not needed, it has to be decoupled with capacitors.

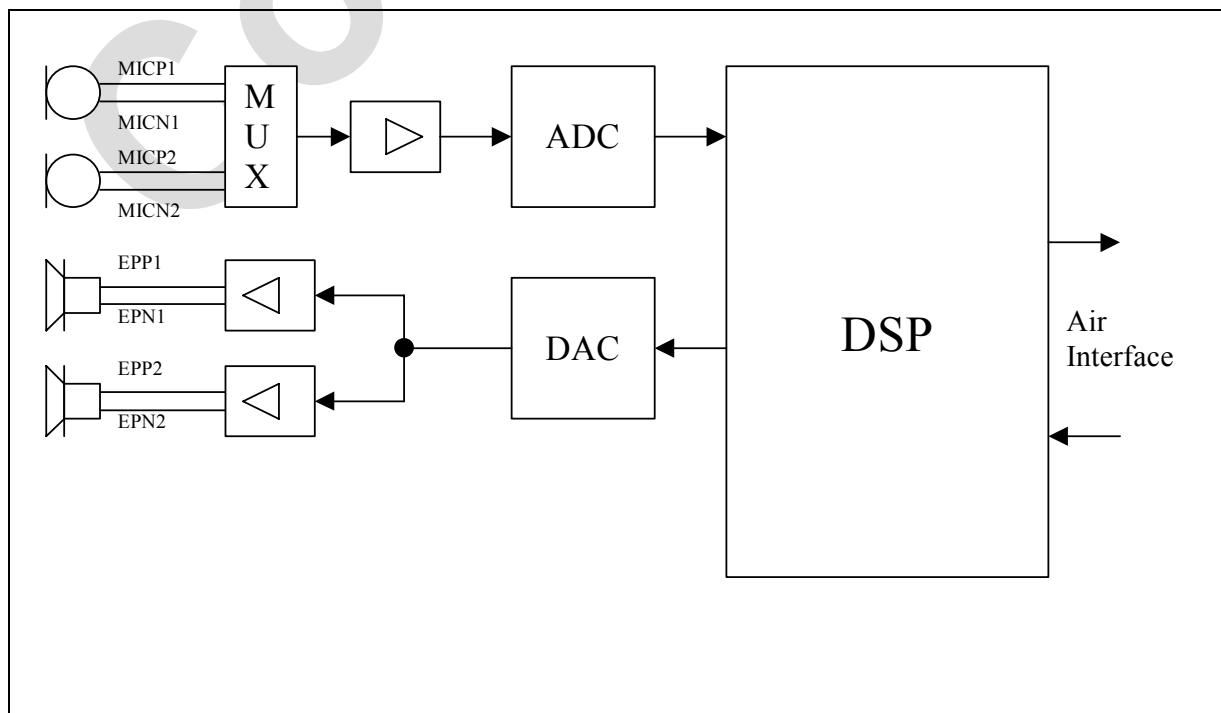

Figure 17: Audio block diagram

3.7.1 Speech processing

The speech samples from the ADC are handled by the DSP of the baseband controller to calculate e.g. amplifications, sidetone, echo cancellation or noise suppression depending on the configuration of the active audio mode. These processed samples are passed to the speech encoder. Received samples from the speech decoder are passed to the DAC after post processing (frequency response correction, adding sidetone etc.).

Full rate, half rate, enhanced full rate, speech and channel encoding including voice activity detection (VAD) and discontinuous transmission (DTX) and digital GMSK modulation are also performed on the GSM baseband processor.

Customer specific audio parameters can be evaluated by Siemens on customer request. These parameters can be downloaded to TC35i using the appropriate AT command. For further details refer to [5] or contact your local Siemens dealer.

3.8 SIM interface

The baseband processor has an integrated SIM interface compatible with the ISO 7816 IC Card standard. This is wired to the host interface (board-to-board connector) in order to be connected to an external SIM card holder. Six pins on the board-to-board connector are reserved for the SIM interface.

The CCIN pin serves to detect whether a tray (with SIM card) is present in the card holder. Using the CCIN pin is mandatory for compliance with the GSM 11.11 recommendation if the mechanical design of the host application allows the user to remove the SIM card during operation. See Chapter 3.8.1 for details.

It is recommended that the total cable length between the board-to-board connector pins on TC35i and the pins of the SIM card holder does not exceed 200 mm in order to meet the specifications of 3GPP TS 51.010-1 and to satisfy the requirements of EMC compliance.

Table 11: Signals of the SIM interface (board-to-board connector)

Signal	Description
CCGND	Separate ground connection for SIM card to improve EMC.
CCCLK	Chipcard clock, various clock rates can be set in the baseband processor.
CCVCC	SIM supply voltage from PSU-ASIC
CCIO	Serial data line, input and output.
CCRST	Chipcard reset, provided by baseband processor.
CCIN	Input on the baseband processor for detecting a SIM card tray in the holder. The CCIN pin is mandatory for applications that allow the user to remove the SIM card during operation. The CCIN pin is solely intended for use with a SIM card. It must not be used for any other purposes. Failure to comply with this requirement may invalidate the type approval of TC35i.

3.8.1 Requirements for using the CCIN pin

According to ISO/IEC 7816-3 the SIM interface must be immediately shut down once the SIM card is removed during operation. Therefore, the signal at the CCIN pin must go low *before* the SIM card contacts are mechanically detached from the SIM interface contacts. This shut-down procedure is particularly required to protect the SIM card as well as the SIM interface of TC35i from damage.

An appropriate SIM card detect switch is required on the card holder. For example, this is true for the model supplied by Molex, which has been tested to operate with TC35i and is part of the Siemens reference equipment submitted for type approval. Molex ordering number is 91228-0001, see also Chapter 81.

The module's startup procedure involves a SIM card initialization performed within 1 second after getting started. An important issue is whether the initialization procedure ends up with a high or low level of the CCIN signal:

- a) If, during startup of TC35i, the CCIN signal on the SIM interface is high, then the status of the SIM card holder can be recognized each time the card is inserted or ejected. A low level of CCIN indicates that no SIM card tray is inserted into the holder. In this case, the module keeps searching, at regular intervals, for the SIM card. Once the SIM card tray with a SIM card is inserted, CCIN is taken high again.
- b) If, during startup of TC35i, the CCIN signal is low, the module will also attempt to initialize the SIM card. In this case, the initialization will only be successful when the card is present. If the SIM card initialization has been done, but the card is no more operational or removed, then the module will never search again for a SIM card and only emergency calls can be made.

Removing and inserting the SIM card during operation requires the software to be reinitialized. Therefore, after reinserting the SIM card it is necessary to restart TC35i. It is strongly recommended to connect the contacts of the SIM card detect switch to the CCIN input and to the CCVCC output of the module as illustrated in the sample diagram in Figure 18.

Note: No guarantee can be given, nor any liability accepted, if loss of data is encountered after removing the SIM card during operation.

Also, no guarantee can be given for properly initializing any SIM card that the user inserts after having removed a SIM card during operation. In this case, the application must restart TC35i.

3.8.2 Design considerations for SIM card holder

The schematic below is a sample configuration that illustrates the Molex SIM card holder located on the DSB35 Support Box (evaluation kit used for type approval of the Siemens TC35i reference setup, see [4] for technical details). X1201 is the designation used in [4] to refer to the SIM card holder.

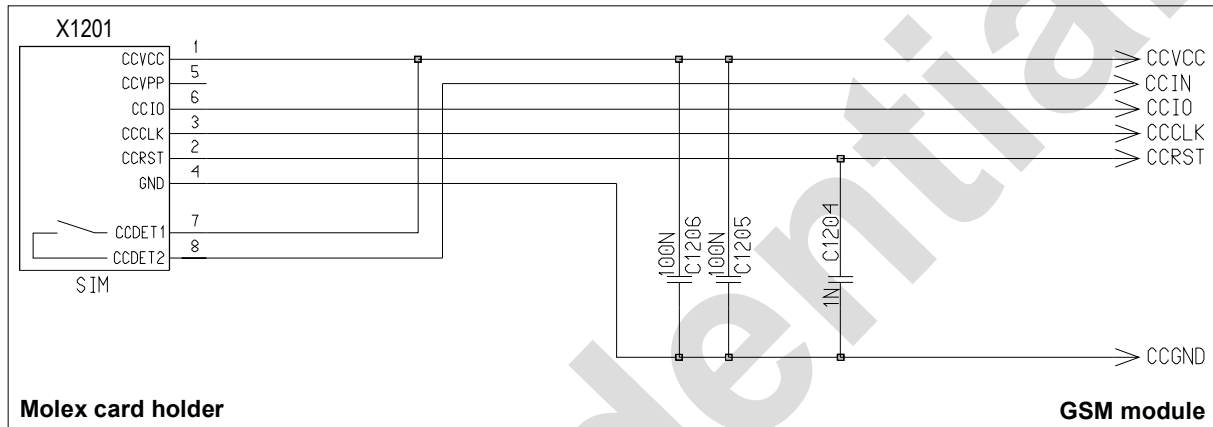

Figure 18: SIM card holder of DSB35 Support Box

Table 12: Pin assignment of Molex SIM card holder on DSB35 Support Box

Pin no.	Signal name	I/O	Function
1	CCVCC	I	Supply voltage for SIM card, generated by the GSM engine
2	CCRST	I	Chip card reset, prompted by the GSM engine
3	CCCLK	I	Chip card clock
4	CCGND	-	Individual ground line for the SIM card to improve EMC
5	CCVPP	-	Not connected
6	CCIO	I/O	Serial data line, bi-directional
7	CCDET1	-	Connect to CCVCC
8	CCDET2		Connects to the CCIN input of the GSM engine. Serves to recognize whether a SIM card is in the holder.

Pins 1 through 8 (except for 5) are the minimum requirement according to the GSM Recommendations, where pins 7 and 8 are needed for SIM card tray detection through the CCIN pin.

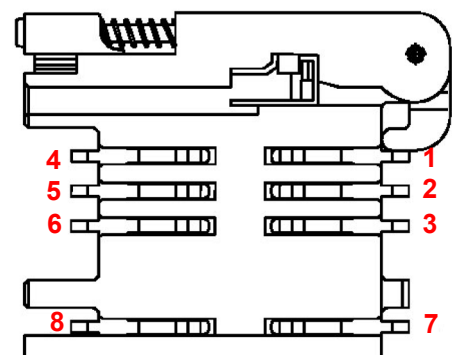

Figure 19: Pin numbers of Molex SIM card holder on DSB45 Support Box

Place the capacitors C1205 and C1206 (or instead one capacitor of 200nF) as close as possible to the pins 1 (CCVCC) and 4 (GND) of the card holder. Connect the capacitors to the pins via low resistance tracks.

3.9 Control signals

3.9.1 Inputs

Table 13: Input control signals of the TC35i module

Signal	Pin	Pin status	Function	Remarks
Ignition	/IGT	= falling edge	Power up TC35i	Active low \geq 100ms (open drain/collector driver required in cellular device application) Note: If a charger and a battery is connected to the customer application the /IGT signal must be 1s minimum.
		= 1	Hi-Z	
Emergency shutdown	/EMERG-OFF	= 0	Power down TC35i	Active low \geq 3.2s (Open drain/collector driver required in cellular device application). At the /EMERGOFF signal the watchdog signal of the GSM engine can be traced (see description in Table 23).
		= 1	Hi-Z	

(HiZ = high impedance)

3.9.2 Outputs

3.9.2.1 Synchronization signal

The synchronization signal serves to indicate growing power consumption during the transmit burst. The signal is generated by the SYNC pin (pin number 32). Please note that this pin can adopt two different operating modes which you can select by using the AT^SSYNC command (mode 0 and 1). For details refer to the "AT Command Set".

To generate the synchronization signal the pin needs to be configured to mode 0 (= default). This setting is recommended if you want your application to use the synchronization signal for better power supply control. Your platform design must be such that the incoming signal accommodates sufficient power supply to the TC35i module if required. This can be achieved by lowering the current drawn from other components installed in your application. The characteristics of the synchronization signal are explained below.

Table 14: TC35i synchronization signal (if SYNC pin is set to mode 0 via AT^SSYNC)

Function	Pin	Status	Description
Synchronization	SYNC	= 0	No operation
		= 1	Indicates increased power consumption during transmission.

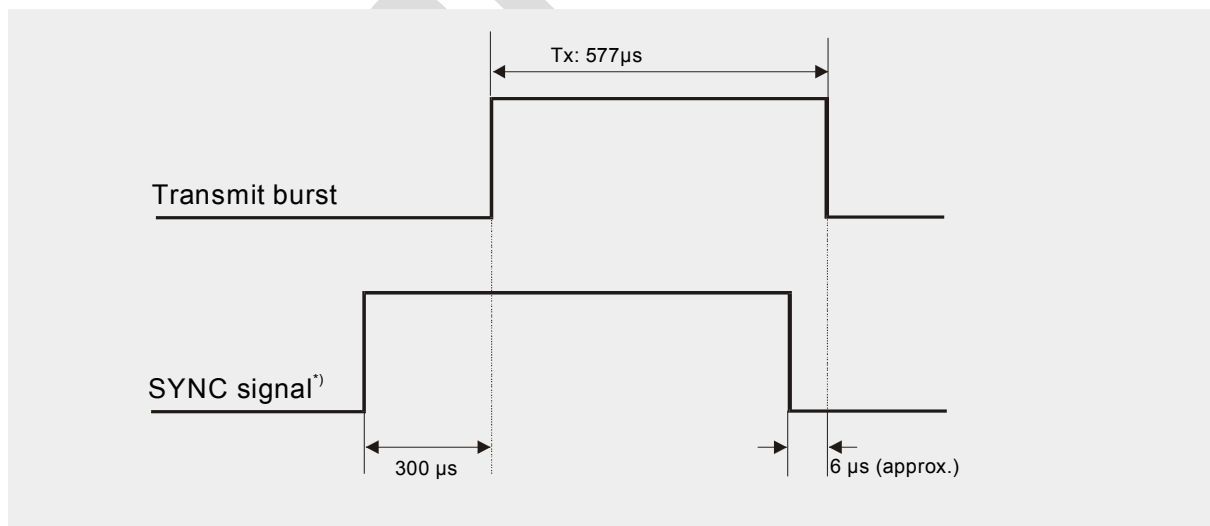

Figure 20: TC35i output control signals

^{*)} The duration of the SYNC signal is always equal, no matter whether the traffic or the access burst are active.

3.9.2.2 Using the SYNC pin to control a status LED

As an alternative to generating the synchronization signal, the SYNC pin can be used to control a status LED on your application platform.

To avail of this feature you need to set the SYNC pin to mode 1 by using the AT[^]SSYNC command. For details see [1].

When controlled from the SYNC pin the LED can display the following functions:

Table 15: Modes of the LED and associated functions

LED mode	Operating status
Off ^{*)}	TC35i is off or run in SLEEP, Alarm or Charge-only mode.
600 ms On / 600ms Off ^{*)}	No SIM card inserted or no PIN entered, or network search in progress, or ongoing user authentication, or network login in progress.
75ms On / 3s Off ^{*)}	Logged to network (monitoring control channels and user interactions). No call in progress.
On	Depending on type of call: <i>Voice call:</i> Connected to remote party. <i>Data call:</i> Connected to remote party or exchange of parameters while setting up or disconnecting a call.

^{*)} LED Off = SYNC pin low. LED On = SYNC pin high (if LED is connected as illustrated in Figure 21)

To operate the LED a buffer, e.g. a transistor or gate, must be included in your application. A sample configuration can be gathered from Figure 21. Power consumption in the LED mode is the same as for the synchronization signal mode. For details see Table 23 pin number 32.

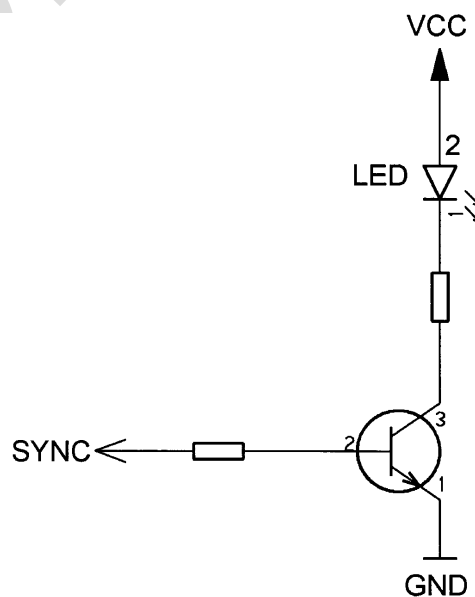

Figure 21: LED Circuit (Example)

3.9.2.3 Behaviour of the /RING0 line

The /RING0 line is available on the serial interface. Its behaviour depends on the type of the call received.

- When a *voice call* comes in the /RING0 line goes low for 1s and high for another 4s. Every 5 seconds the ring string is generated and sent over the /RXD0 line. If there is a call in progress and call waiting is activated for a connected handset or handsfree device, the /RING0 line switches to ground in order to generate acoustic signals that indicate the waiting call.

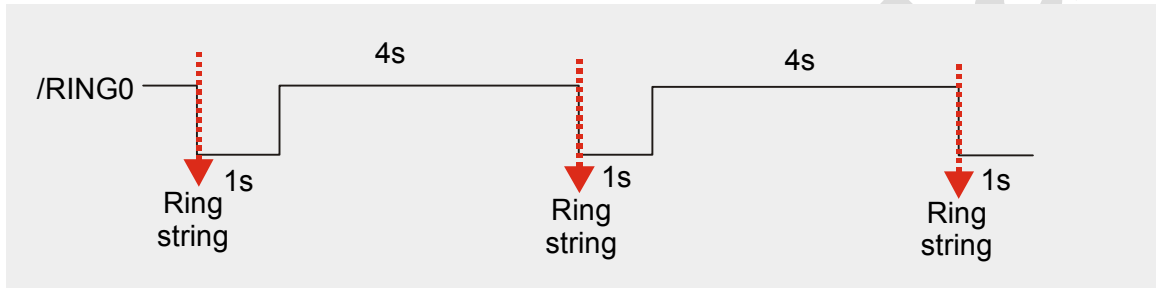

Figure 22: Incoming voice call

- Likewise, when a *Fax or data call* is received, /RING0 goes low. However, in contrast to voice calls, the line remains low. Every 5 seconds the ring string is generated and sent over the /RXD0 line.

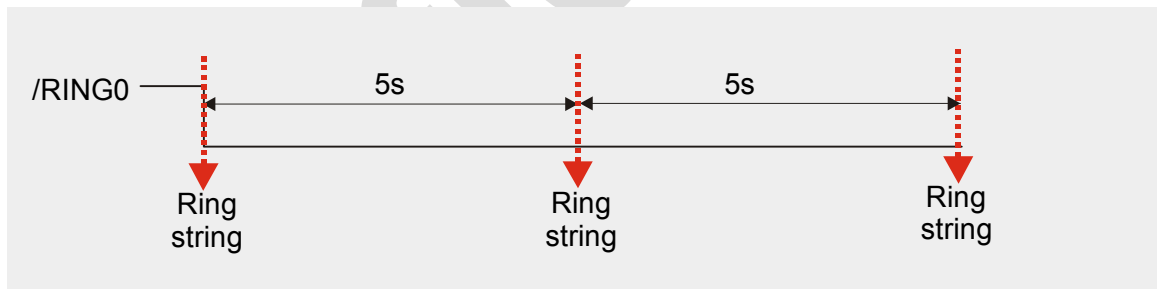

Figure 23: Incoming data call

- All types of Unsolicited Result Codes (URCs) also cause the /RING0 line to go low, however for 1 second only. For example, TC35i may be configured to output a URC upon the receipt of an SMS. As a result, if this URC type was activated with AT+CNMI=1,1, each incoming SMS causes the /RING0 line to go low. See [1] for detailed information on URCs.

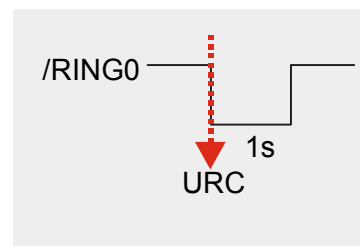

Figure 24: URC transmission

Table 16: TC35i ring signal

Function	Pin	Status	Description
Ring indication	/RING0	0	Indicates an incoming call or URC. If in NON-CYCLIC SLEEP mode CFUN=0 or CYCLIC SLEEP mode CFUN=5 or 6, the module is caused to wake up to full functionality. If CFUN=7 or 8, power saving is resumed after URC transmission or end of call.
		1	No operation

4 RF interface

The RF interface has an impedance of 50Ω. TC35i is capable of sustaining a total mismatch at the antenna connector without any damage, even when transmitting at maximum power level. The antenna jack located on the TC35i PCB is a MuRata GSC coaxial connector (see Figure 25).

The external antenna must be matched properly at least to achieve best performance regarding radiated power, DC-power consumption and harmonic suppression. Please note that the receiver is designed to use the direct conversion concept.

Regarding the return loss TC35i provides the following values.

Table 17: Return loss

State of module	Return loss of module	Recommended return loss of application
Receive	≥ 8dB	≥ 12dB
Transmit	not applicable	≥ 12dB
Idle	≤ 5dB	not applicable

A 27nH inductor to ground provides additional ESD protection for the antenna connector. To protect the inductor from damage no DC voltage must be applied to the antenna circuit.

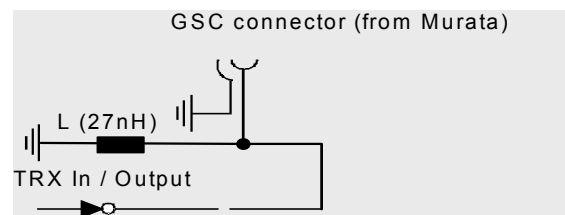

Figure 25: Antenna connector circuit on TC35i

4.1 Antenna connector

TC35i uses a GSC connector to establish the RF connection to the host application. Below please find brief ordering information to help you retrieve further details from the manufacturer MuRata, e.g. under <http://www.murata.com>.

Table 18: MuRata ordering information

Description	MuRata part number
Male connector mounted on TC35i	MM9329-2700
Matching female connectors suited for individual cable assembly <ul style="list-style-type: none"> • Right-angle flexible cable • Right-angle flexible cable • Right-angle semirigid cable 	MXTK88xxxx MXTK92xxxx MXTK91xxxx

The physical dimensions and maximum mechanical stress limits can be gathered from the table and the figures below. To securely fasten or remove the antenna cable MuRata recommends to use the P/N M22001 engagement/disengagement tool.

Table 19: Ratings and characteristics of the GSC antenna connector

Item	Specification				
Frequency range	DC to 6GHz				
VSWR	1.2 max. (DC to 3 GHz), 1.3 max. 3GHz to 6GHz)				
Nominal impedance	50Ω				
Temperature range	-40°C to +90°C				
Contact resistance	15mΩ max.				
Withstanding voltage	AC300V				
Insulation resistance	500MΩ min.				
Material and finish <ul style="list-style-type: none"> • Center contact: • Outer contact: • Insulator: 	<table style="width: 100%; border: none;"> <tr> <td style="width: 33%;">Material:</td> <td style="width: 33%;">Finish:</td> </tr> <tr> <td> <ul style="list-style-type: none"> • Copper alloy • Copper alloy • Engineering plastic </td> <td> <ul style="list-style-type: none"> Gold plated Silver plated None </td> </tr> </table>	Material:	Finish:	<ul style="list-style-type: none"> • Copper alloy • Copper alloy • Engineering plastic 	<ul style="list-style-type: none"> Gold plated Silver plated None
Material:	Finish:				
<ul style="list-style-type: none"> • Copper alloy • Copper alloy • Engineering plastic 	<ul style="list-style-type: none"> Gold plated Silver plated None 				

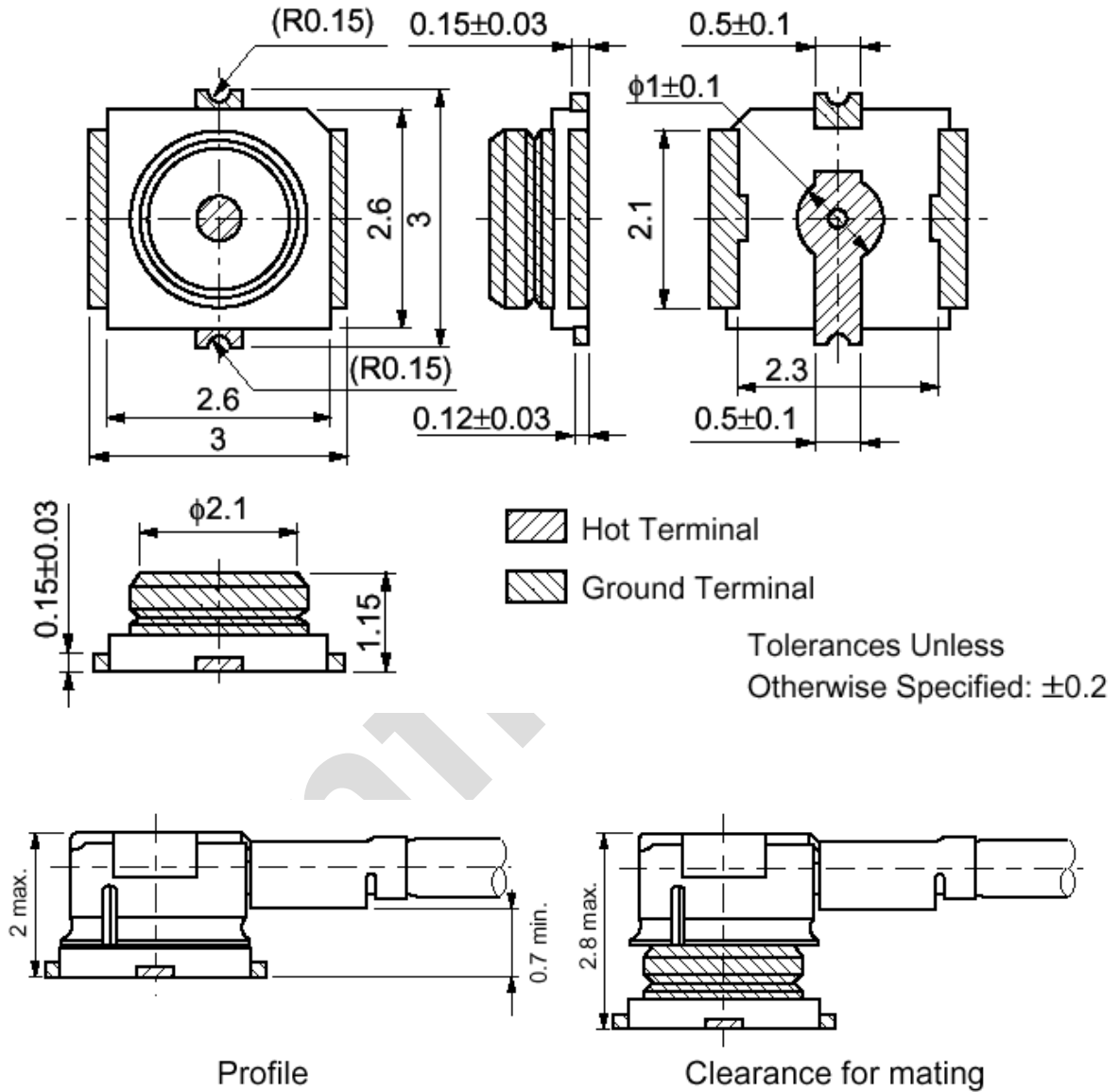

Figure 26: Mechanical dimensions of MuRata GSC connector (in mm)

Table 20: Stress characteristics of the GSC antenna connector

Parameter	Specification
Connector durability	100 cycles of mating and withdrawal with a jig at 12 cycles/minute maximum
Engage force	30N max
Disengage force	3N min, 30N max
Angle of engagement	15 degree max
Mechanical stress to connector	See Table 19 for details
<ul style="list-style-type: none"> Stress to the housing: Stress to outer sleeve: Cable pull strength: 	A and B: 4.9N max. C: 2.94N max and D: 1.96N max E: 4.9N max

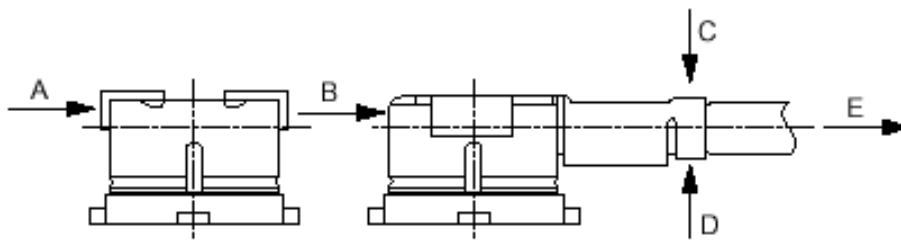

Figure 27: Maximum mechanical stress to the connector

The following figure illustrates the engagement/disengagement tool type P/N M22001 recommended by MuRata and provides instructions for proper use.

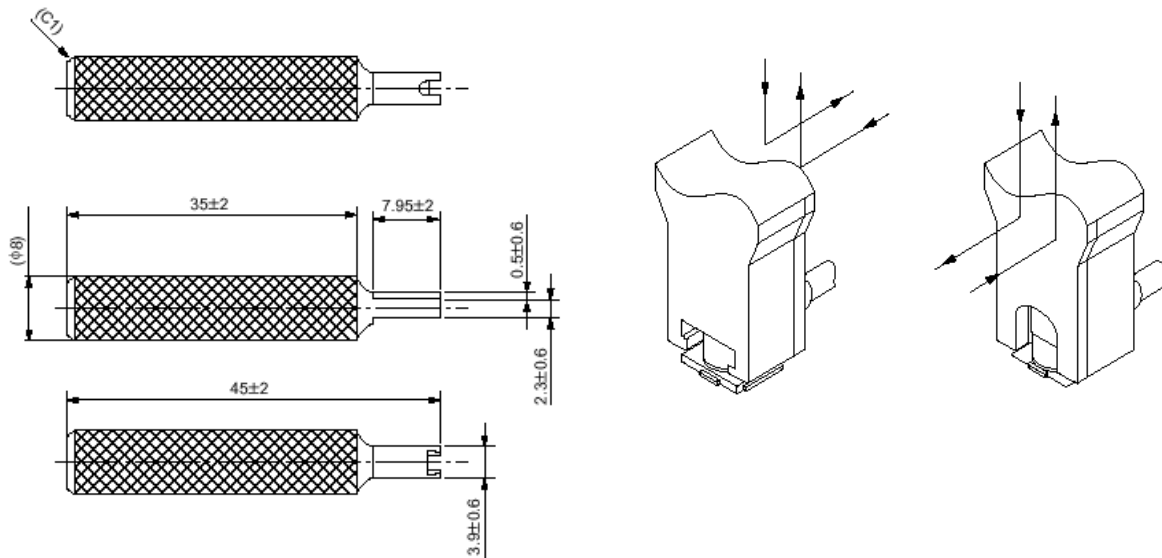

Figure 28: How to use MuRata tool

5 Electrical, reliability and radio characteristics

5.1 Absolute maximum ratings

Absolute maximum ratings for supply voltage and voltages on digital and analog pins of TC35i are listed in Table 21. Exceeding these values will cause permanent damage to the GSM Engine. The supply current must be limited accordingly. The safety status of the power supply is subject to SELV (as defined by EN60950)

Table 21: Absolute maximum ratings

Parameter	Min	Max	Unit
Voltage at digital pins	-0.3	3.3	V
Voltage at analog pins	-0.3	3.0	V
Voltage at POWER pins		20	V
Current at POWER pins		800	mA
Voltage at digital / analog pins in POWER DOWN mode	-0.25	+0.25	V
BATT+	-0.3	5.5	V

5.2 Operating conditions

5.2.1 Temperature conditions

Test conditions were specified in accordance with IEC 60068-2 (still air). The values stated below are in compliance with GSM recommendation TS 51.010-1.

Table 22: Temperature conditions

Parameter	Min	Typ	Max	Unit
Ambient temperature (according to GSM 11.10)	-20	25	55	°C
Restricted operation ^{*)}	-25 to -20		55 to 70	°C
Automatic shutdown: if application is not battery powered if application is battery powered	≤-25		≥70 ^{**)}	°C
	≤-18		≥60 ^{**)}	°C
Charging temperature (software controlled fast charging)	0		+45	°C

^{*)} TC35i works, but deviations from the GSM specification may occur.

^{**)} Limited performance if $V_{BATT+ \max} \leq 4.0V$ and PCL5 is required at $T_{amb \max} = 70^{\circ}C$

Please note that the reference voltages listed below are the values measured directly on the TC35i module. They do not apply to the accessories connected.

5.3 Electrical specifications of the application interface

Please note that the reference voltages listed in Table 23 are the values measured directly on the TC35i module. They do not apply to the accessories connected.

If an input pin is specified for $V_{i,h \max}=3.3V$, ensure never to exceed the stated voltage. The value 3.3V is an absolute maximum rating.

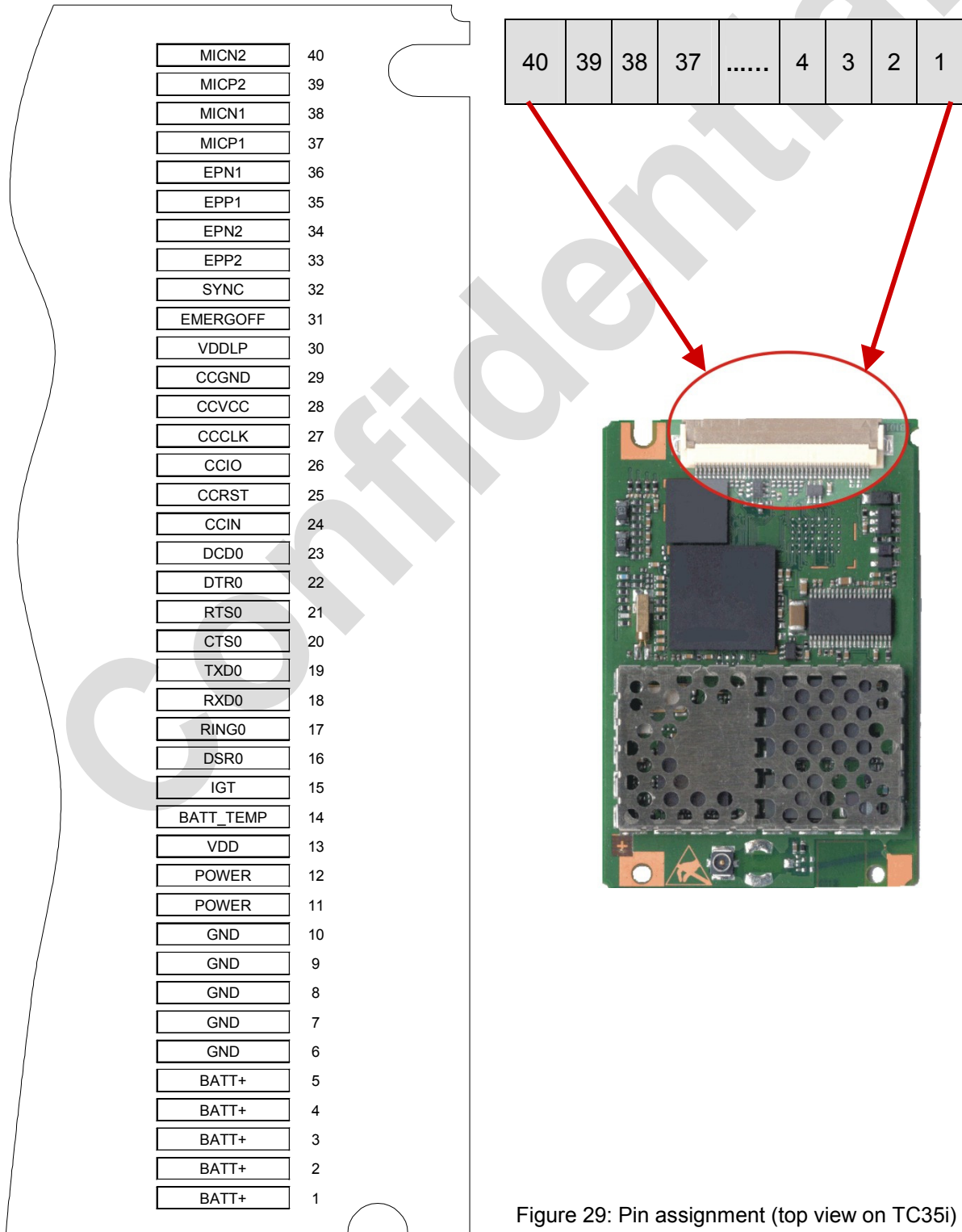

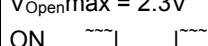

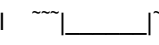

Figure 29: Pin assignment (top view on TC35i)

CONFIDENTIAL

The reference voltages listed in Table 23 are the values measured directly on the TC35i GSM engine. They do not apply to the accessories connected.

Table 23: Pin assignment and electrical description of application interface

Function	Signal name	IO	Signal form and level	Comment
Power supply	BATT+	I	$V_I = 3.3V$ to $4.8V$ $V_{I,typ} = 4.2V$ $I_{nom} \approx 2A$, in Burst  1 Tx, Peak current $577\mu s$ every $4.616ms$	Five pins of BATT+ and GND must be switched in parallel for supply purposes because peaks of up to 3A occur.
Power supply	GND		Ground	Application Ground
Charge Interface	POWER	I	$V_{Imin} = 3.0V$ $V_{Imax} = 15V$ $I_{max} = 500mA$	This line signalizes to the processor that the charger is connected. If unused keep pin open.
	BATT_TEMP	I	Connect NTC with $R_{NTC} \approx 10k\Omega @ 25^\circ C$ to ground.	Battery temperature measurement via NTC resistance. NTC should be installed inside or near battery pack to enable the charging algorithm and deliver temperature values. If unused keep pin open.
External supply voltage	VDD	O	IDLE / TALK mode: $V_{out} = 2.9V; \pm 3\% @ 70mA; V_{BATT+} = 4.2V$ and $T_{amb,typ} = 25^\circ C$ $V_{out} = 2.9V; \pm 3\% @ 20mA;$ $V_{BATT+} = 4.8V$ and $T_{amb,typ} = 25^\circ C$ $I_{max} = 70mA$ Power Down mode: $V_{out} = 0V$ $C_{load,max,extern} = 1\mu F$	Can be used, for example, to connect a level converter or a pull-up resistor. Not recommended for components operated by pulse current. If unused keep pin open. Not available in power down mode. The external digital logic must not cause any spikes or glitches on voltage VDD. VDD signals "ON" state of module. Voltage is applied ca. 60ms after IGT was driven low
Ignition	/IGT	I	$R_I \approx 100k\Omega, C_I \approx 1nF$ $V_{IL,max} = 0.5V$ at $I_{max} = -20\mu A$ $V_{Openmax} = 2.3V$ ON  Active Low $\geq 100ms$	This signal switches the mobile ON. This line must be driven low by an Open Drain or Open Collector driver.

Function	Signal name	IO	Signal form and level	Comment
Emergency shutdown	/EMERGOFF	I	$R_I \approx 22k\Omega$ $V_{ILmax} = 0.45V$ at $I_{max} = -100\mu A$ $V_{Openmax} = 2.25V$ Signal  Active Low $\geq 3.2s$ Watchdog: $V_{OLmax} = 0.35V$ at $I = 10\mu A$ $V_{OHmin} = 2.25V$ at $I = -10\mu A$ $f_{Omin} = 0.16Hz$ $f_{Omax} = 1.55Hz$	This line must be driven by an Open Drain or Open Collector driver. Emergency shutdown deactivates the modules power supply. A reset can be done with a following IGT. For mobile switching off use AT command AT^SMSO. EMERGOFF also indicates the internal watchdog function. If unused keep pin open.
Synchroni- zation	SYNC	O	$V_{OLmax} = 0.3V$ at $I = 0.1mA$ $V_{OHmin} = 2.25V$ at $I = -0.1mA$ $V_{OHmax} = 2.73V$  1 Tx, 877µs impulse each 4.616ms, with 300µs forward time.	Indication of increased current consumption during uplink transmission burst, however, the timing is different during handover. Alternatively used to control status LED. If unused keep pin open.
SIM Interface	CCIN	I	$R_I \approx 100k\Omega$ $V_{ILmax} = 0.5V$ $V_{IHmin} = 2.15V$ at $I = 20\mu A$, $V_{IHmax} = 3.3V$ at $I = 30\mu A$	CCIN = high, SIM card holder closed (no card recognition) Maximum cable length or copper track 200mm to SIM card holder. All signals of SIM interface are protected against ESD with a special diode array. Usage of CCGND is mandatory.
	CCRST	O	$R_O \approx 47\Omega$ $V_{OLmax} = 0.25V$ at $I = 1mA$ $V_{OHmin} = 2.3V$ at $I = -1mA$ $V_{OHmax} = 2.73V$	
	CCIO	IO	$R_I \approx 10k\Omega$ $V_{ILmax} = 0.5V$ $V_{IHmin} = 1.95V$, $V_{IHmax} = 3.3V$ $R_O \approx 220\Omega$ $V_{OLmax} = 0.4V$ at $I = 1mA$ $V_{OHmin} = 2.15V$ at $I = -1mA$ $V_{OHmin} = 2.55V$ at $I = -20\mu A$ $V_{OHmax} = 2.96V$	
	CCCLK	O	$R_O \approx 220\Omega$ $V_{OLmax} = 0.4V$ at $I = 1mA$ $V_{OHmin} = 2.15V$ at $I = -1mA$ $V_{OHmax} = 2.73V$	
	CCVCC	O	$R_{Omax} = 5\Omega$ $CCVCCmin = 2.84V$, $CCVCCmax = 2.96V$ $I_{max} = 20mA$	
	CCGND		Ground	
RTC backup	VDDL	I/O	IDLE / TALK / DATA / Power down mode if BATT+ connected: $V_{out} < BATT+$ $R_i = 1k\Omega$ (serial resistor) PD mode if BATT+ disconnected $V_{in} = 2.0V \dots 5.5V$ $I_{in,max} = 30 \mu A$	If unused, keep pin open.

Function	Signal name	IO	Signal form and level	Comment	
Serial interface	/RXD0	O	$V_{OLmax} = 0.3V @ I = 0.1mA$ $V_{OHmin} = 2.25V @ I = -0.1mA$ $V_{OHmax} = 2.73V$ $V_{IImax} = 0.4V$ $V_{IHmin} = 1.95V, V_{IHmax} = 3.45V$ RTS0, DTR0: $I_{max} = -90\mu A @ V_{IN} = 0V$ TXD0: $I_{max} = -30\mu A @ V_{IN} = 0V$ $V_{IL} = 0.25V$	Serial interface for AT-Commands or Data stream. If lines are unused keep pins open.	
	/TXD0	I			
	/CTS0	O			
	/RTS0	I			
	/DTR0	I			
	/DCD0	O			
	/DSR0	O			
	/RING0	O			
Analog Audio interface	EPP2	I	$R_i \approx 15\Omega$, (30k Ω if not active) gain range -18...0dB in 6 dB steps Max. output differential DC offset 100mV $V_{Out} = 3.7V_{pp}$ typical, $V_{Out} = 3.07V_{pp}$ max, $V_{Out} = 3.03V_{pp}$ min, measurement conditions: sine signal, 3.14 dBm0, 1024Hz, load resistance = 200k Ω audio mode = 5, outBbcGain = 0, outCalibrate = 16384	The audio output is balanced and can directly operate an earpiece. If unused keep pins open. Short circuit may damage the outputs.	
	EPN2	O			
	EPP1	I	$R_i \approx 15\Omega$, (30k Ω if not active) gain range -18...0dB in 6 dB steps Max. output differential DC offset 100mV $V_{Out} = 3.7V_{pp}$ typical, $V_{Out} = 4.07V_{pp}$ max, $V_{Out} = 3.03V_{pp}$ min, @ measurement conditions: sine signal, 3.14 dBm0, 1024Hz, load resistance = 200k Ω audio mode = 6, outBbcGain = 0, outCalibrate = 16384		The audio output is balanced and can directly operate an earpiece. If unused keep pins open. Short circuit may damage the outputs
	EPN1	I			
	MICP1	O	$R_i = 2k\Omega$ differential $V_{I,max} = 1.03V_{pp}$ $V_{supply} = 2.65V$ at $R_{supply} = 4k\Omega$ analog amplification range = 0...42dB in 6dB steps		This microphone input is balanced and can feed an active microphone. If unused keep pins open.
	MICN1	O			
	MICP2	O	$R_i = 2k\Omega$ differential $V_{I,max} = 1.03V_{pp}$ $V_{supply} = 2.65V$ at $R_{supply} = 4k\Omega$ analog amplification range = 0...42dB in 6dB steps		This microphone input is balanced and can feed an active microphone. If unused keep pins open.
	MICN2	I			

Explanation of signal names:
 P = positive, N = negative

5.4 Power supply ratings

Table 24: Power supply ratings

Parameter	Description	Conditions	Min	Typ	Max	Unit
V _{BATT+}	Supply voltage	Directly measured at the reference point VBATT+ Voltage must stay within the min/max values, including voltage drop, ripple, spikes.	3.3	4.2	4.8	V
	Voltage drop during transmit burst ¹⁾	Normal condition, power control level for P _{out max}			400	mV
	Voltage ripple ¹⁾	Normal condition, power control level for P _{out max} @ f<200kHz @ f>200kHz			50 2	mV
I _{BATT+}	Average supply current	Power Down mode		50	100	μA
		SLEEP mode		3		mA
		IDLE mode GSM		25		mA
		TALK mode GSM		300	400	mA
	Peak supply current (during 577μs transmission slot every 4.6ms)	Power control level for P _{out max} I _{max}		2	3.5	A
I _{CHARGE}	Charging current	Li-Ion battery pack			500	mA
	Trickle charging ²⁾	U _{battery} 0...3.6V			9.0	mA

¹⁾ see Chapter 3.2.2

²⁾ see Chapter 0

5.4.1 Current consumption during transmit burst

The diagrams in Figure 30 through Figure 31 illustrate the peak current consumption of the application caused during a transmit burst. The peak current is shown vs. the power level for GSM900/1800 and vs. the return loss of the antenna. All measurements have been performed at 25°C and different supply voltages (reference points used on module: test points on ZIF connector). Changing the conditions, e.g. in terms of temperature or voltage, will cause different results. The current will be maximized when the maximum supply voltage is used together with a total reflection at the RF interface. Using a supply voltage higher than 4.3V at PCL5 GSM 900 lets the peak current rise by about 150mA, due to higher RF output power.

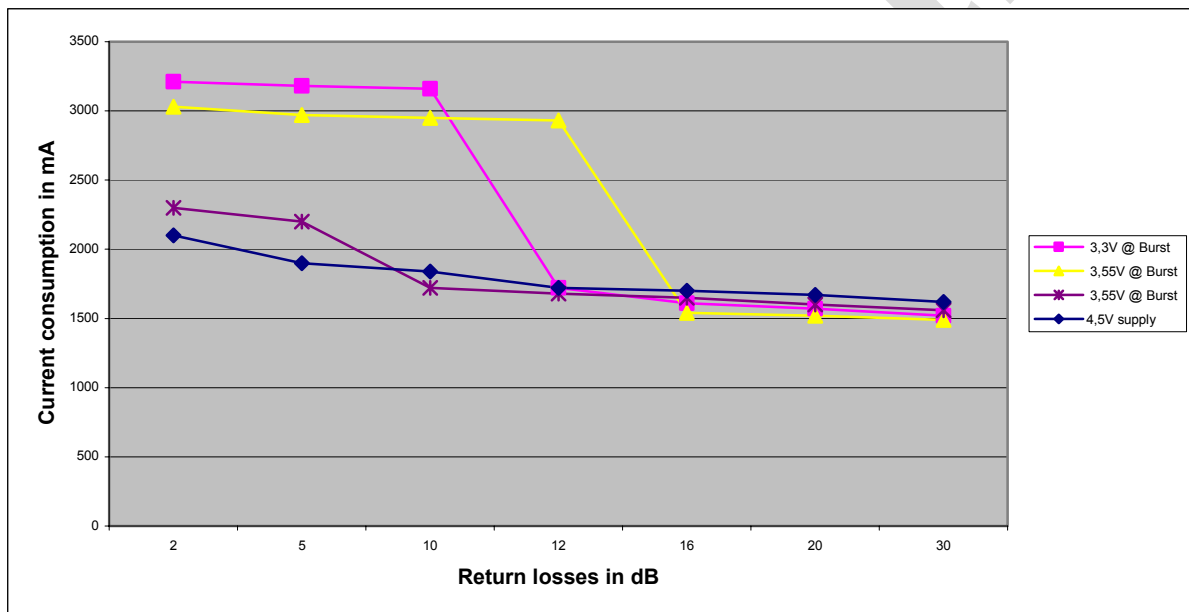

Conditions: $T_{amb} = 25^{\circ}\text{C}$; ARFCN = mid range

Figure 30: Current consumption during transmit burst

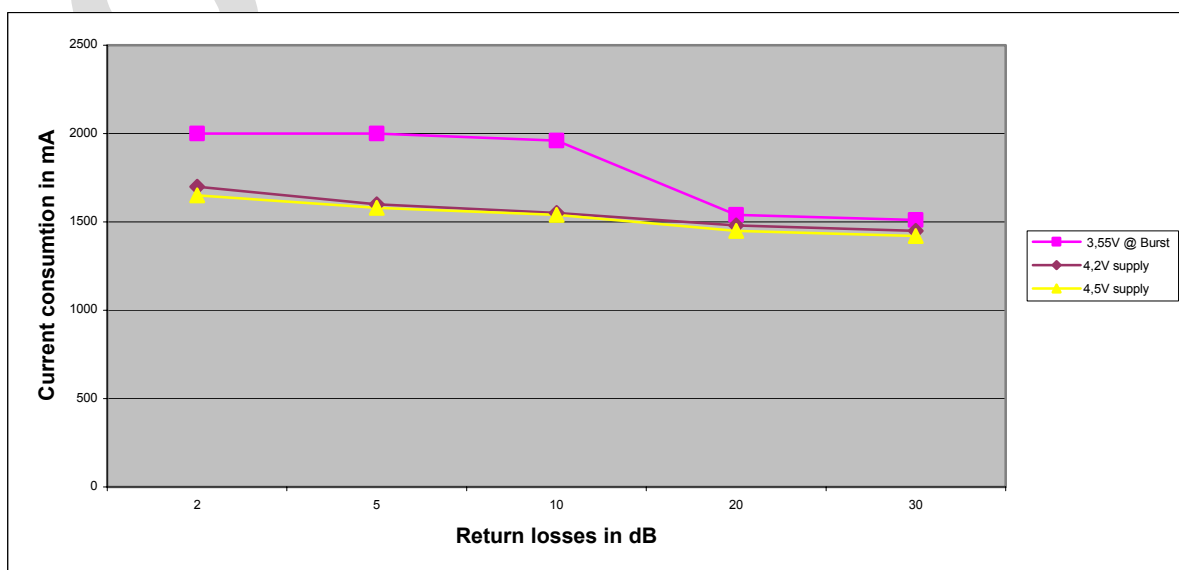

Conditions: $T_{amb} = 25^{\circ}\text{C}$; ARFCN = mid range

Figure 31: Current consumption during transmit burst

5.5 Electrical characteristics of the voiceband part

5.5.1 Setting audio parameters by AT command

The audio modes 2 and 6 can be adjusted according to the parameters listed below. Each audio mode is assigned a separate set of parameters.

Table 25: Audio parameters adjustable by AT command

Parameter	Influence to	Range	Gain range	Calculation
inBbcGain	MICP/MICN analogue amplifier gain of baseband controller before ADC	0...7	0...42dB	6dB steps
inCalibrate	digital attenuation of input signal after ADC	0...32767	-∞...0dB	$20 * \log(\text{inCalibrate}/32768)$
outBbcGain	EPP/EPN analogue output gain of baseband controller after DAC	0...3	0...-18dB	6dB steps
outCalibrate[n] n = 0...4	digital attenuation of output signal after speech decoder, before summation of sidetone and DAC present for each volume step[n]	0...32767	-∞...+6dB	$20 * \log(2 * \text{outCalibrate}[n]/32768)$
sideTone	digital attenuation of sidetone is corrected internally by outBbcGain to obtain a constant sidetone independent of output volume	0...32767	-∞...0dB	$20 * \log(\text{sideTone}/32768)$

Note: The parameters inCalibrate, outCalibrate and sideTone accept also values from 32768 to 65535. These values are internally truncated to 32767.

5.5.2 Audio programming model

The audio programming model shows how the signal path can be influenced by varying the AT command parameters. The parameters *inBbcGain* and *inCalibrate* can be set with AT^SNFI. All the other parameters are adjustable with AT^SNFO.

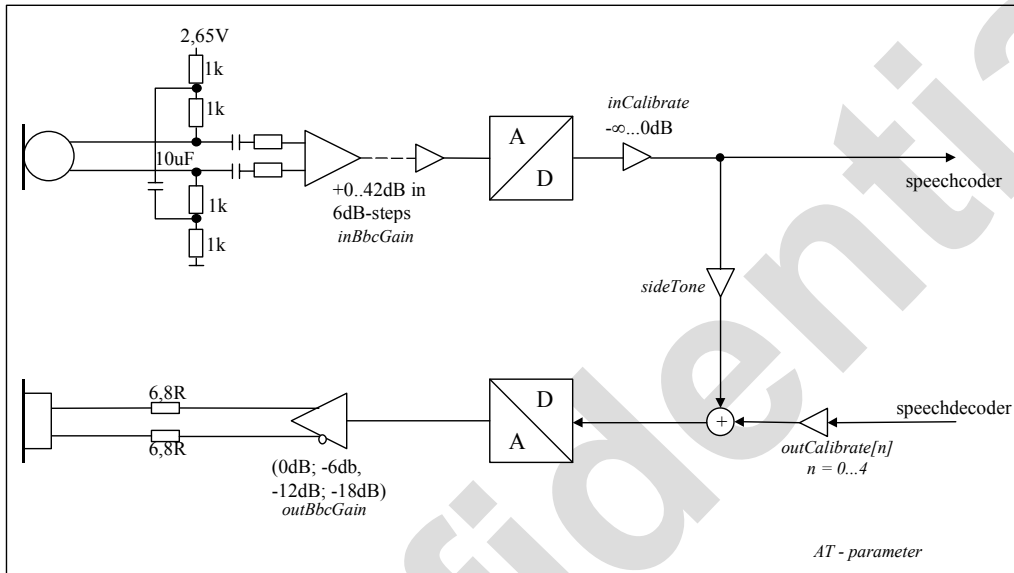

Figure 32: AT audio programming model

5.5.3 Characteristics of audio modes

The electrical characteristics of the voiceband part depend on the current audio mode set with the AT[^]SNFS command.

Table 26: Voiceband characteristics (typical), all values preliminary

Audio mode no. AT [^] SNFS=	1 (Default settings, not adjustable)	2	3	4	5	6
Name	Default Handset	Basic Handsfree	Headset	User Handset	Plain Codec 1	Plain Codec 2
Purpose	DSB with Votronic handset	Siemens Car Kit Portable	Siemens Headset	DSB with individual handset	Direct access to speech coder	Direct access to speech coder
Gain setting via AT command. Defaults:	Fix	Adjustable	Adjustable	Adjustable	Adjustable	Adjustable
inBbcGain	5 (30dB)	1 (6dB)	4 (24dB)	5 (30dB)	0 (0dB)	0 (0dB)
outBbcGain	1 (-6dB)	1 (-6dB)	2 (-12dB)	1 (-6dB)	0 (0dB)	0 (0dB)
MICPn/MICNn EPPn/EPNn	n=1	n=2	n=2	n=1	n=1	n=2
Power supply	ON	ON	ON	ON	OFF	OFF
Sidetone	ON	---	Adjustable	Adjustable	Adjustable	Adjustable
Volume control	OFF	Adjustable	Adjustable	Adjustable	Adjustable	Adjustable
Limiter (receive)	ON	ON	ON	ON	---	---
Compressor (receive)	---	ON ¹⁾	---	---	---	---
AGC (send)	OFF	---	ON	---	---	---
Echo control (send)	Suppression	Cancellation + suppression	---	Suppression	---	---
Noise suppression ²⁾	---	up to 10dB	10dB	---	---	---
MIC input signal for 0dBm0 @ 1024 Hz (default gain)	12.5mV	98mV	11mV @ -3dBm0 due to AGC	12.5mV	315mV	315mV
EP output signal in mV rms. @ 0dBm0, 1024 Hz, no load (default gain); @ 3.14 dBm0	275mV	120 mV default @ max volume	270mV default @ max volume	275 mV default @ max volume	880mV	880mV
					3.7 Vpp	3.7 Vpp
Sidetone gain at default settings	27.7dB	-∞ dB	Affected by AGC, 9.3dB @ 11mV (MIC)	27.7 dB	-2.7dB @ sideTone = 8192 ³⁾	-2.7dB @ sideTone = 8192 ³⁾

¹⁾ Adaptive, receive volume increases with higher ambient noise level.

²⁾ In audio modes with noise reduction, the microphone input signal for 0dBm0 shall be measured with a sine burst signal for a tone duration of 5 seconds and a pause of 2 sec. The sine signal appears as noise and, after approx. 12 sec, is attenuated by the noise reduction by up to 10dB.

³⁾ See AT[^]SNFO command in [1].

Note: With regard to acoustic shock, the cellular application must be designed to avoid sending false AT commands that might increase amplification, e.g. for a high sensitive earpiece. A protection circuit should be implemented in the cellular application.

5.5.4 Voiceband receive path

The values specified below were tested to 1kHz and 0dB gain stage, unless otherwise stated.

gs = 0dB means audio mode = 5 for EPP1 to EPN1 and 6 for EPP2 to EPN2, inBbcGain= 0, inCalibrate = 32767, outBbcGain = 0, OutCalibrate = 16384, sideTone = 0.

Table 27: Voiceband receive path

Parameter	Min	Typ	Max	Unit	Test condition / remark
Differential output voltage (peak to peak)	3.33	3.7	4.07	V	from EPPx to EPNx gs = 0dB @ 3.14 dBm0
Differential output gain settings (gs) at 6dB stages (outBbcGain)	-18		0	dB	
fine scaling by DSP (outCalibrate)	$-\infty$		0	dB	
Output differential DC offset			100	mV	gs = 0dB, outBbcGain = 0 and -6dB
Differential output resistance	13	15		Ω	from EPPx to EPNx
Absolute gain accuracy			0.8	dB	Variation due to change in VDD, temperature and life time
Attenuation distortion			1	dB	for 300...3900Hz, @ EPPx/EPNx (333Hz) / @ EPPx/EPNx (3.66kHz)
Out-of-band discrimination	60			dB	for $f > 4$ kHz with in-band test signal @ 1kHz and 1kHz RBW

gs = gain setting

5.5.5 Voiceband transmit path

The values specified below were tested to 1kHz and 0dB gain stage, unless otherwise stated.

Audio mode = 5 for MICP1 to MICN1 and 6 for MICP2 to MICN2, inBbcGain= 0, inCalibrate = 32767, outBbcGain = 0, OutCalibrate = 16384, sideTone = 0

Table 28: Voiceband transmit path

Parameter	Min	Typ	Max	Unit	Test condition/Remark
Input voltage (peak to peak) MICP1 to MICN1, MICP2 to MICN2			1.03	V	
Input amplifier gain in 6dB steps (inBbcGain)	0		42	dB	
fine scaling by DSP (inCalibrate)	$-\infty$		0	dB	
Input impedance		2.0		k Ω	
Microphone supply voltage ON Ri = 4k Ω	2.57 2.17 1.77	2.65 2.25 1.85	2.73 2.33 1.93	V V V	no supply current @ 100 μ A @ 200 μ A
Microphone supply voltage OFF Ri = 4k Ω		0		V	
Microphone supply in power down mode					see Figure 33

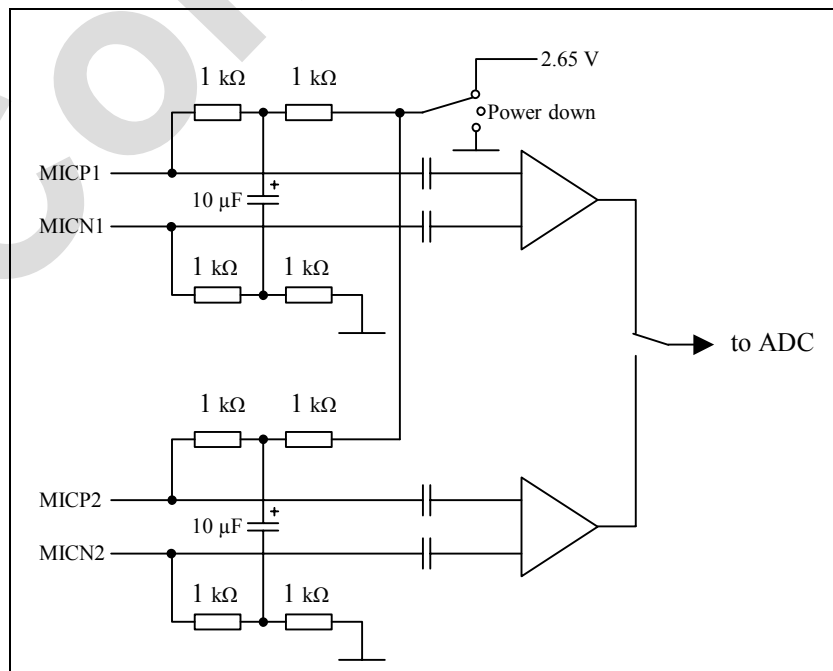

Figure 33: Structure of audio inputs

5.6 Air interface

Table 29: Air Interface

Parameter		Min	Typ	Max	Unit
Frequency range Uplink (MS → BTS)	E-GSM 900	880		915	MHz
	GSM 1800	1710		1785	MHz
Frequency range Downlink (BTS → MS)	E-GSM 900	925		960	MHz
	GSM 1800	1805		1880	MHz
RF power @ ARP with 50Ω load	E-GSM 900 ¹⁾	31	33		dBm
	GSM 1800 ²⁾	28	30		dBm
Number of carriers	E-GSM 900		174		
	GSM 1800		374		
Duplex spacing	E-GSM 900		45		MHz
	GSM 1800		95		MHz
Carrier spacing			200		kHz
Multiplex, Duplex	TDMA / FDMA, FDD				
Time slots per TDMA frame			8		
Frame duration			4.615		ms
Time slot duration			577		µs
Modulation	GMSK				
Receiver input sensitivity @ ARP	E-GSM 900	- 104	-105		dBm
BER Class II < 2.4%	GSM 1800	- 102	-105		dBm

¹⁾ at power level 5

²⁾ at power level 0

Table 30: Local oscillator and intermediate frequencies used by TC35i

All frequencies in MHz		Frequency Band	Local Oscillator	Intermediate Frequency
E-GSM 900	TX	880 - 915	1470 - 1550	90 - 115
	RX	925 - 960	1385 - 1440	0
PCN 1800	TX	1710 - 1785	1350 - 1415	90 - 115
	RX	1805 - 1880	1350 - 1415	0

5.7 Electrostatic discharge

The GSM engine is not protected against Electrostatic Discharge (ESD) in general. Consequently, it is subject to ESD handling precautions that typically apply to ESD sensitive components. Proper ESD handling and packaging procedures must be applied throughout the processing, handling and operation of any application that incorporates a TC35i module.

Despite of this, the antenna port, the SIM interface, the BATT_TEMP port, the POWER port and the Battery lines are equipped with spark gaps and clamp diodes to protect these lines from overvoltage. For all the other ports, ESD protection must be implemented on the application platform that incorporates the GSM engine.

TC35i has been tested and found to comply with the EN 61000-4-2 directive. The measured values verified for the Siemens reference configuration can be gathered from the following table.

Table 31: Measured electrostatic values

Specification / Requirements	Contact discharge	Air discharge
ETSI EN 301 489-7		
ESD at SIM port	± 4kV	± 8kV
ESD at antenna port	± 4kV	± 8kV
ESD at power pins BATT+, GND, POWER	± 4kV	± 8kV
ESD at BATT_TEMP	± 4kV	± 8kV
Human Body Model (test conditions: 1.5 kΩ, 100 pF)		
ESD at the module	± 1kV	

Please note that the values may vary with the individual application design. For example, it matters whether or not the application platform is grounded over external devices like a computer or other equipment, such as the Siemens reference application described in Chapter 7.

5.8 Reliability characteristics

The test conditions stated below are an extract of the complete test specifications.

Table 32: Summary of reliability test conditions

Type of test	Conditions	Standard
Vibration	Frequency range: 10-20 Hz; acceleration: 3.1mm amplitude Frequency range: 20-500 Hz; acceleration: 5g Duration: 2h per axis = 10 cycles; 3 axes	DIN IEC 68-2-6
Shock half-sinus	Acceleration: 500g Shock duration: 1msec 1 shock per axis 6 positions (\pm x, y and z)	DIN IEC 68-2-27
Dry heat	Temperature: $+70 \pm 2^{\circ}\text{C}$ Test duration: 16 h Humidity in the test chamber: $< 50\%$	EN 60068-2-2 Bb ETS 300019-2-7
Temperature change (shock)	Low temperature: $-40^{\circ}\text{C} \pm 2^{\circ}\text{C}$ High temperature: $+85^{\circ}\text{C} \pm 2^{\circ}\text{C}$ Changeover time: $< 30\text{s}$ (dual chamber system) Test duration: 1 h Number of repetitions: 100	DIN IEC 68-2-14 Na ETS 300019-2-7
Damp heat cyclic	High temperature: $+55^{\circ}\text{C} \pm 2^{\circ}\text{C}$ Low temperature: $+25^{\circ}\text{C} \pm 2^{\circ}\text{C}$ Humidity: $93\% \pm 3\%$ Number of repetitions: 6 Test duration: 12h + 12h	DIN IEC 68-2-30 Db ETS 300019-2-5
Cold (constant exposure)	Temperature: $-40 \pm 2^{\circ}\text{C}$ Test duration: 16 h	DIN IEC 68-2-1

6 Mechanics

6.1 Mechanical dimensions of TC35i

Figure 34 shows the RF part of TC35i and provides an overview of the board's mechanical dimensions. For further details see Figure 35.

Size: $54.5 \pm 0.2 \times 36 \pm 0.2 \times 3.6 \pm 0.2$ mm (height of antenna connector not considered)
Weight: 9g

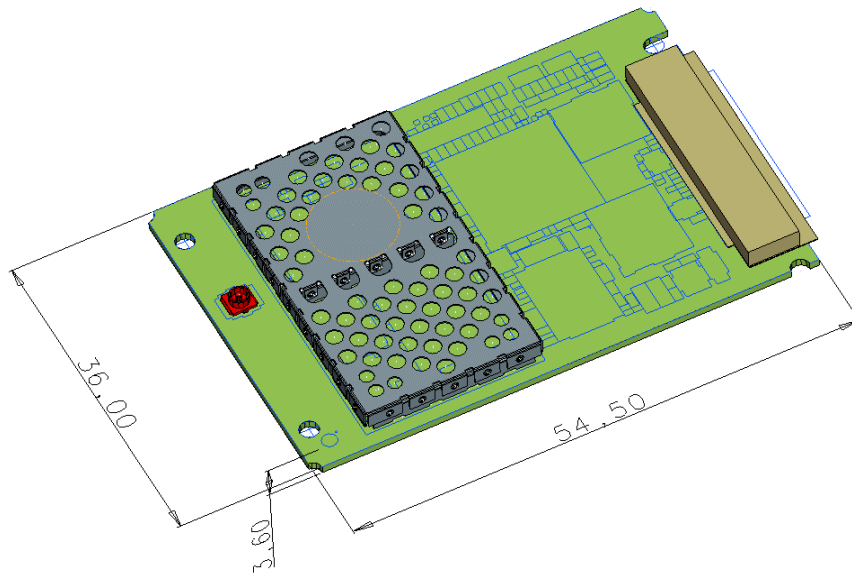
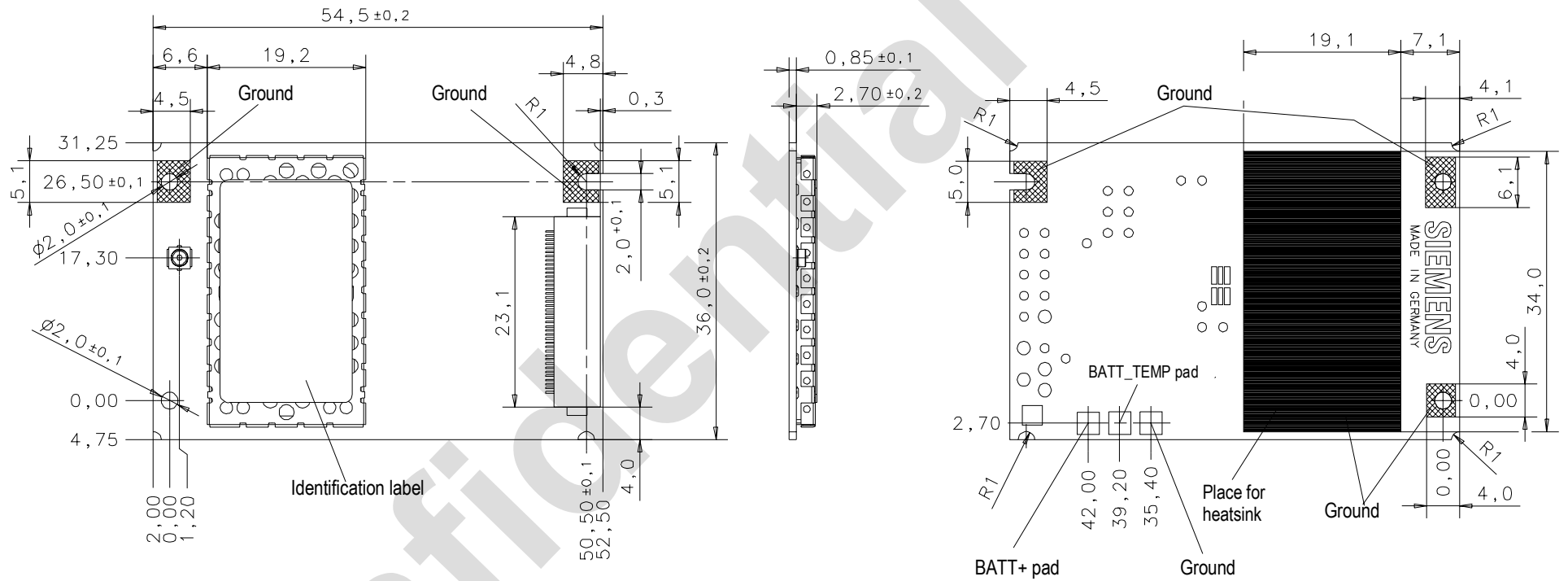

Figure 34: TC35i – top view



All dimensions in millimeter

Figure 35: Mechanical dimensions of TC35i

6.2 Mounting TC35i onto the application platform

For the cellular application to operate reliably it is essential that the GSM engine is securely attached to the host housing.

The TC35i board provides three mounting holes. To properly mount it to the host device you can use M1.6 or M1.8 screws plus suitable washers. The maximum diameter of the screw head incl. the washer must not exceed 4 mm.

To prevent mechanical damage, be careful not to force, bend or twist the GSM engine. Be sure it is positioned flat against the host device.

Avoid placing the TC35i board tightly to the host device. Instead, it is recommended to set spacers between the module and the host device. If your design approach does not allow for spacers make sure the host device provides an opening for the RF part.

Avoid exerting any pressure on the shielding covers. Contact springs or other components must not be fastened to the covers. In extreme conditions, you run the risk of short-circuit if the cover was damaged or distorted due to pressure. Furthermore, the covers must not be used to apply any solder joints.

6.3 ZIF connector (application interface)

This chapter provides specifications for the 40-pin ZIF connector which serves as physical interface to the host application. The connector assembled on the TC35i PCB is type Hirose FH12-40S 0.5 SH.

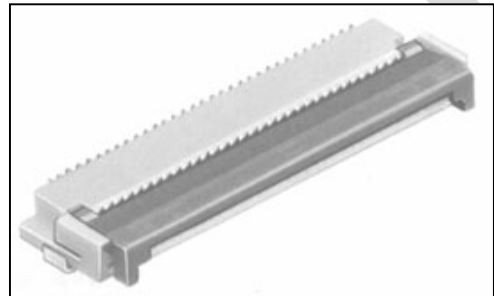

Figure 36: Hirose FH12 connector

The ZIF (zero insertion force) design allows to easily fasten or remove the cable without the need for special tools. Simply insert the FFC into the open socket without using any pressure. Then carefully close the socket lid until the contacts of the socket grip the cable contacts.

Table 33: Ordering information

Item	Part number	Pitch (mm)	HRS number
ZIF connector	FH12-40S 0.5 SH	0.5	CL586-0527-7

Table 34: Electrical and mechanical characteristics of Hirose FH12-40S 0.5 SH connector

Parameter	Specification (40 pin ZIF connector)
Number of Contacts	40
Quantity delivered	2000 Connectors per Tape & Reel
Voltage	50V
Current Rating	0.4A max per contact
Resistance	0.05 Ohm per contact
Dielectric Withstanding Voltage	150V RMS AC for 1min
Operating Temperature	-40°C...+85°C
Contact Material	phosphor bronze finish: solder plating
Insulator Material	PPS, deep brown / Polyamide, beige
FFC/FPC Thickness	0.3mm ±0.05mm (0.012" ±0.002")
Maximum connection cycles	20 (@ 50mOhm max)
Cable	FFC (Flat Flexible Cable), max. length 200mm from SIM interface

6.3.1 FFC

As stated in Chapter 3.8 the total cable length between the ZIF connector pins on TC35i and the pins of the SIM card holder must not exceed 200 mm in order to meet the specifications of 3GPP TS 51.010-1 and to satisfy the requirements of EMC compliance.

7 Reference Approval

7.1 Reference Equipment

The Siemens reference setup that will be submitted to type approve TC35i consists of the following components:

- Siemens TC35i cellular engine
- Development Support Box (DSB35)
- FFC from ZIF connector on TC35i to application interface on DSB35.
- SIM card holder integrated on the DSB35
- Handset type Votronic HH-SI-30.3/V1.1/0
- PC as MMI

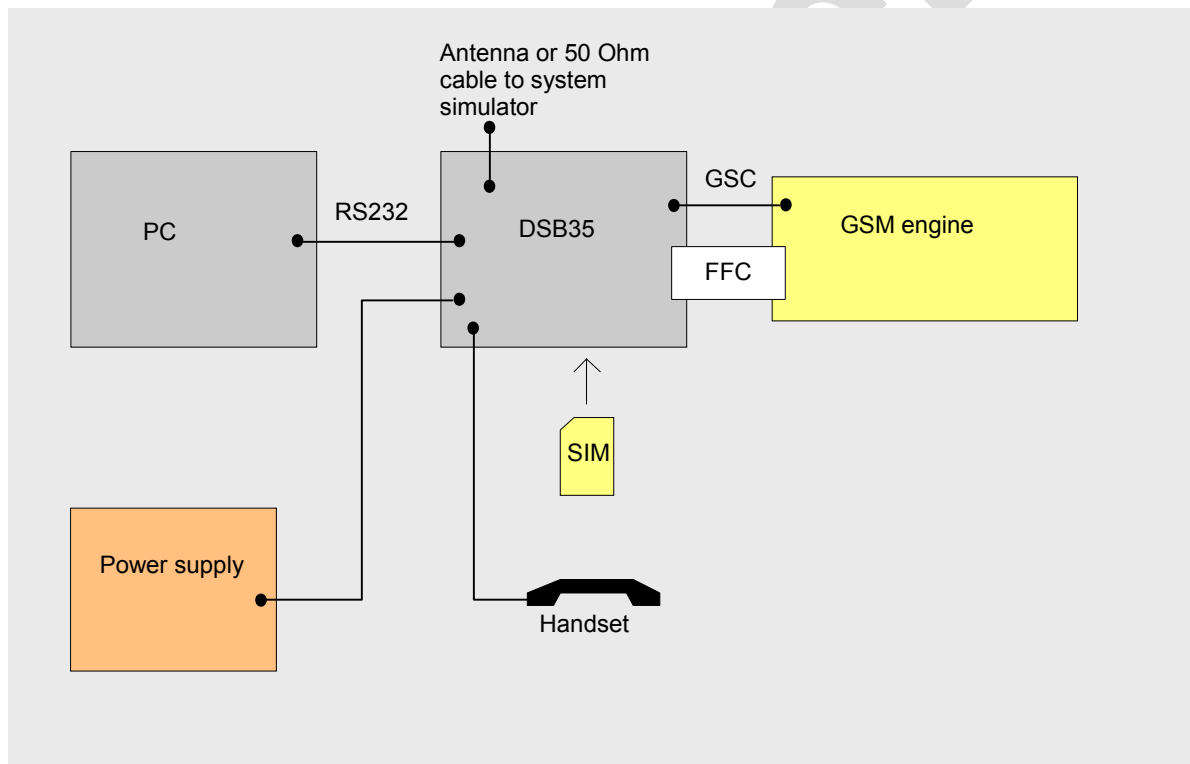

Figure 38: Reference equipment for approval

For the Siemens TC35i, an IMEI number contingent has been reserved for the basic approval of the reference configuration. It will also apply to later approvals of customer configurations incorporating the GSM engine.

Approved Siemens TC35i configurations are recorded in the approval documentation. Later enhancements and modifications beyond the certified configuration require extra approvals. Each supplementary approval process includes submittal of the technical documentation as well as testing of the changes made. The relevant test applications for supplementary approvals should be agreed upon with Siemens.

8 APPENDIX: List of parts and recommended accessories

Table 35: List of accessories

Description	Supplier	Ordering information
TC35i engine	Siemens	Siemens ordering number L36880-N8110-A200
SIM card holder incl. push button ejector and slide-in tray	Molex	Ordering numbers: 91228 91236 Molex Deutschland GmbH Felix-Wankel-Str. 11 D-74078 Heilbronn-Biberach Phone: +49(7066)9555 0 Fax: +49(7066)9555 29 Email: mxgermany@molex.com Web site: http://www.molex.com/ American Headquarters Lisle, Illinois 60532 U.S.A. Phone: 1-800-78MOLEX Fax: 630-969-1352 Far East Headquarters Yamato, Kanagawa, Japan Phone: 81-462-65-2324 Fax: 81-462 Far East Headquarters Jurong, Singapore Phone: 65-268-6868 Fax: 65-265-6044
ZIF connector	Hirose	See Chapter 6.3 for specifications of FH12-40S 0.5 SH connector and mating cables http://www.hirose.com
Flat cable for ZIF connector cable 160 mm cable 80 mm	Axon	Ordering numbers: FFC 0.50 A 40 / 0160 K4.0-4.0-08.0-08.0SABB FFC 0.50 A 40 / 0080 K4.0-4.0-08.0-08.0SABB
RF cable GSC-GSC cable 50 mm cable 100 mm	MuRata	Ordering numbers: MXTK 88 TK 0500 MXTK 88 TK 1000
GSC connector	MuRata	MM9329-2700 TB2
P/N M22001 tool (recommended for GSC antenna installation)	MuRata	Please use product name: P/N M22001

Description	Supplier	Ordering information
Battery cell XWODA	Shenzhen Xwoda Electronic Co., Ltd	<p>To place orders or obtain more information please contact:</p> <p>Shenzhen Xwoda Electronic Co., Ltd Building C, Tongfukang Industrial Zone Shiyang Town Bao'an District Shenzhen P.R.China</p> <p>Contact: Waichard Tsui Phone: +86-755-27623789 ext. 370 Fax: +86-755-27623078 Email: waichard@xwoda.com.cn</p> <p>Info: Http://xwoda.com.cn</p>
Handset	Votronic	HH-SI-30.3/V1.1/0
Siemens Car Kit Portable	Siemens	Siemens ordering number L36880-N3015-A117
DSB35 Support Box	Siemens	Siemens ordering number L36880-N8101-A100-3
BB35 Bootbox	Siemens	Siemens ordering number L36880-N8102-A100-1