

WISMO Quik Q2400-C series

Q2406-C and Q2426-C Product Specification

Reference: **WM_PRJ_Q2400-C_PTS_001**

Revision: **004**

Date: **8th October 2003**



Document Information

Revision	Date	History of the evolution	
001	24 Oct 02	Creation (Preliminary version) based on WM_PRJ_Q2400_PTS_002, Rev. 001 for WISMO Quik Q2406	
002	2 April 2003	Extract of Design guidelines information. General update. Remove of RF antenna pad connection.	
003	1 st September 2003	<ul style="list-style-type: none">• §2.9 / §3.1: I/O type changed for GPO2 and GPO3• §2.10 / §3.1: I/O type and description changed for FLASH LED signal• §3.3.2: Mechanical drawings updated	
004	8 th October 2003	§3.3.2 - : Mechanical drawings updated Increase of the length tolerances of the module for V-scoring tolerances integration	

Contents

Document Information.....	2
Contents.....	3
Caution.....	6
Trademarks	6
Overview	7
Reference Documents	8
1 General description.....	9
1.1 General information.....	9
1.2 Functional description	10
1.2.1 RF functionalities	11
1.2.2 Baseband functionalities.....	11
1.3 Firmware.....	11
2 Interfaces	12
2.1 General Purpose Connector (GPC)	12
2.2 Power supply	13
2.2.1 General description.....	13
2.2.2 Power consumption	14
2.3 Electrical information for digital I/O.....	16
2.4 SPI bus.....	17
2.5 SPI Auxiliary bus	17
2.6 Keyboard interface.....	18
2.7 Main serial link (UART1).....	19
2.8 SIM interface.....	21
2.8.1 General Description	21
2.8.2 SIM 3/5V management.....	22
2.9 General Purpose Input/Output	23
2.10 Activity status indication	24
2.11 Analog to Digital Converter (ADC)	25

2.12	Audio interface	26
2.12.1	Microphone inputs	26
2.12.1.1	Common microphone inputs characteristics	26
2.12.1.2	Main Microphone Inputs (MIC2)	28
2.12.1.3	Auxiliary Microphone Inputs (MIC1)	28
2.12.2	Speaker outputs	28
2.12.2.1	Common speaker outputs characteristics	28
2.12.2.2	Speaker 2 Outputs	29
2.12.2.3	Speaker 1 Outputs	30
2.12.3	Buzzer Output	30
2.13	Battery charging interface	30
2.13.1	Hardware description	30
2.13.2	Li-ion charging procedure	32
2.14	ON / ~OFF	33
2.14.1	General description	33
2.14.2	Operating sequences	34
2.14.2.1	Power ON	34
2.14.2.2	Power OFF	35
2.15	BOOT (optional)	35
2.16	Reset signal (~RST)	36
2.16.1	General description	36
2.16.2	Reset sequence	37
2.17	External Interrupt (~INTR)	37
2.18	VCC output	38
2.19	Real Time Clock Supply (VCC_RTC)	38
2.20	RF interface	39
2.20.1	RF performances	39
2.20.2	Antenna specifications	40
3	Technical specifications	41
3.1	General Purpose Connector pin out description	41
3.2	Environmental Specifications	45
3.2.1	Operational conditions of functioning	45
3.2.2	Environmental qualification	46
3.3	Mechanical specifications	47
3.3.1	Physical characteristics	47
3.3.2	Mechanical drawings	47
4	Appendix	49
4.1	Wavecom acceptance test	49
4.2	GSM Standard and Recommendations	49
4.3	Safety recommendations (for information only)	52
4.3.1	RF safety	52
4.3.1.1	General	52
4.3.1.2	Exposure to RF energy	52
4.3.1.3	Efficient terminal operation	52

4.3.1.4	Antenna care and replacement	53
4.3.2	General safety.....	53
4.3.2.1	Driving.....	53
4.3.2.2	Electronic devices	53
4.3.2.3	Vehicle electronic equipment	53
4.3.2.4	Medical electronic equipment	53
4.3.2.5	Aircraft	54
4.3.2.6	Children	54
4.3.2.7	Blasting areas.....	54
4.3.2.8	Potentially explosive atmospheres	54
4.4	General Purpose Connector data sheet.....	55
4.5	MMS Connector data sheet.....	62

Caution

Information furnished herein by Wavecom are accurate and reliable. However no responsibility is assumed for its use. Please read carefully the safety precautions for a terminal based on WISMO Quik Q24x6-C sub-series.

General information about Wavecom and its range of products is available at the following internet address: <http://www.wavecom.com>

Trademarks

Some mentioned products are registered trademarks of their respective companies.

Overview

This document defines and specifies the WISMO QUIK Q24x6-C Series, available under two GSM/GPRS Class 10 dual band versions:

- **Q2406A-C**: E-GSM/GPRS **900/1800** MHz version with **16** Mbits of Flash memory and **2** Mbits of SRAM (16/2)
- **Q2406B-C**: E-GSM/GPRS **900/1800** MHz version with **32** Mbits of Flash memory and **4** Mbits of SRAM (32/4)
- **Q2426A-C**: GSM/GPRS **850/1900** MHz version with **16** Mbits of Flash memory and **2** Mbits of SRAM (16/2)
- **Q2426B-C**: GSM/GPRS **850/1900** MHz version with **32** Mbits of Flash memory and **4** Mbits of SRAM (32/4)

This product is dedicated to Automotive applications, driven by AT commands.

Reference Documents

- [1] Automotive Environmental Control Plan For Wismo Quik Q2400-C series
Ref. WM_POA_Q2400-C_DCP_001
- [2] AT Commands Interface Guide
Ref. WM_ASW_OAT_UGD_004
- [3] WISMO Quik Q2400-C Series Customer design Guidelines
Ref: WM_PRJ_Q2400-C_PTS_002
- [4] WISMO Quik Q2400-C Series Manufacturing Guide
Ref: WM_PRJ_Q2400-C_PTS_003

1 General description

1.1 General information

WISMO Quik Q24x6-C sub-series is a range of self-contained E-GSM/GSM-GPRS 900/1800 or 850/1900 dual-band modules including the following features:

- 58.4 x 32.2 x 6.2 mm.
- 2 Watts E-GSM 900/GSM 850 radio section running under 3.6 Volts.
- 1 Watt GSM1800/1900 radio section running under 3.6 Volts.
- Digital section running under 2.8 Volts.
- 3V only SIM interface (for 5 V SIM interface with external adaptation, refer to document [3]).
- Real Time Clock with calendar.
- Battery charge management.
- Echo Cancellation + noise reduction.
- Full GSM or GSM/GPRS software stack.
- Hardware GPRS class 10 capable.
- Complete shielding.
- Complete interfacing through a 60-pin connector:
 - Power supply,
 - Serial link,
 - Audio,
 - SIM card interface,
 - Keyboard.

WISMO Quik Q24x6-C Sub-series has two external connections:

- MMS type RF connector (to the antenna),
- 60-pin General Purpose Connector (GPC) to Digital, Keyboard, Audio and Supply.

WISMO Quik Q24x6-C Sub-series is designed to fit in very small terminals and only some custom functions have to be added to make a complete dual-band solution:

- Keypad,
- Earpiece and Microphone,
- Battery,
- Antenna switch,
- SIM connector.

1.2 Functional description

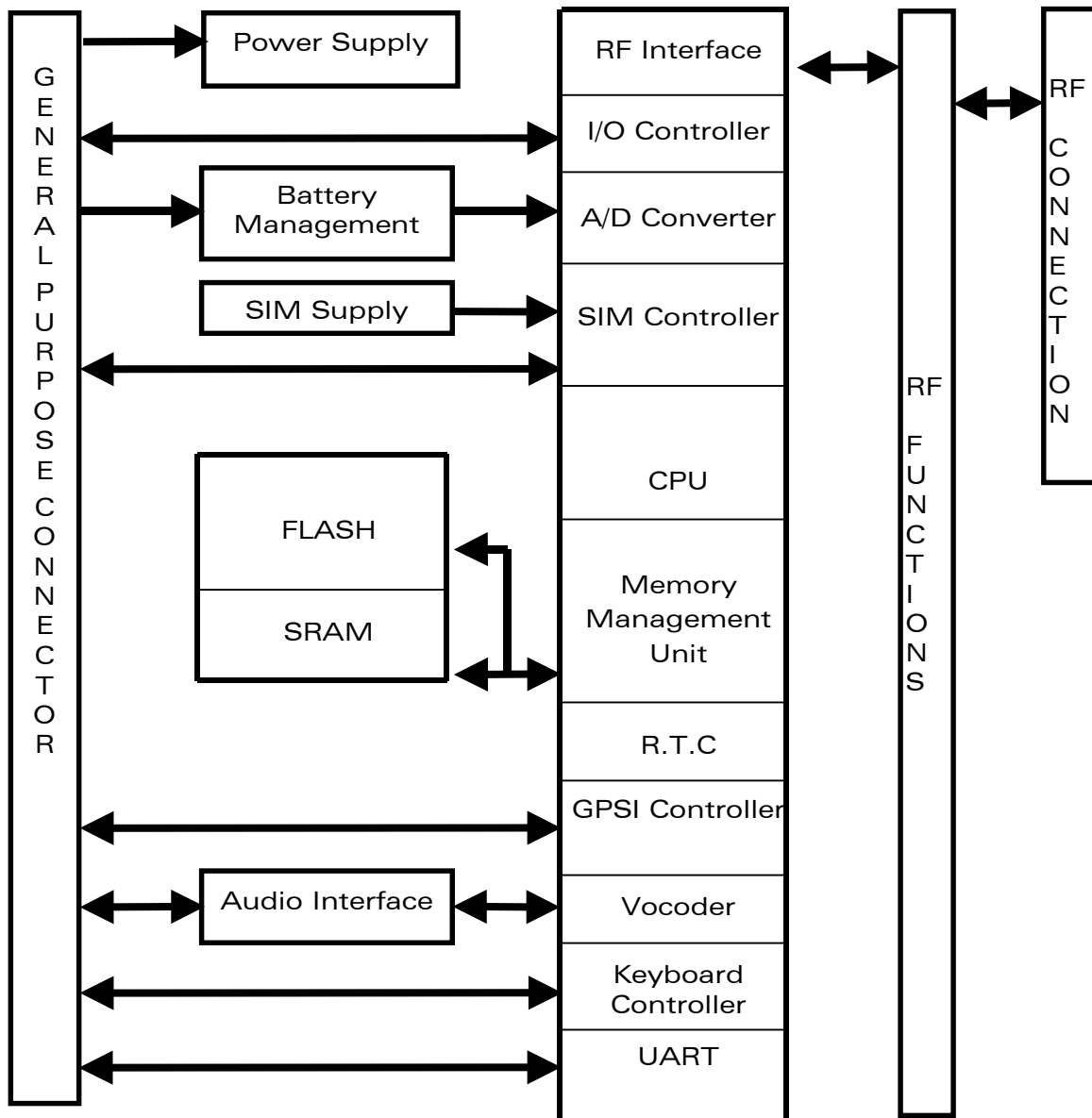

Figure1 : Functional architecture

1.2.1 RF functionalities

The Radio Frequency (RF) functionalities comply with the Phase II E-GSM 900/DCS 1800 and GSM 850/PCS 1900 recommendation.

The frequencies are:

Q2406-C

- Rx (E-GSM 900): 925 to 960 MHz.
- Rx (DCS 1800): 1805 to 1880 MHz.
- Tx (E-GSM 900): 880 to 915 MHz.
- Tx (DCS 1800): 1710 to 1785 MHz.

Q2426-C

- Rx (GSM 850): 869 to 894 MHz.
- Rx (PCS 1900): 1930 to 1990 MHz.
- Tx (GSM 850): 824 to 849 MHz.
- Tx (PCS 1900) : 1850 to 1910 MHz.

The Radio Frequency (RF) part is based on a specific dual band chip including:

- Low-IF Receiver,
- Dual RF (Radio Frequency) synthesizer,
- Digital IF to Baseband Converter,
- Offset PLL (Phase Lock Loop) transmitter,
- 1 (logarithmic) Power Amplifier (PA) controller,
- Dual band Power Amplifier (PA) module.

1.2.2 Baseband functionalities

The digital part of the WISMO Quik Q24x6-C Sub-series is based on a PHILIPS-VLSI chip (ONE C GSM/GPRS Kernel).

This chipset is using a 0.25 μ m mixed technology CMOS, which allows massive integration as well as low current consumption.

1.3 Firmware

WISMO Quik Q24x6-C Sub-series is designed to be integrated into Automotive applications.

For Automotive applications, the firmware offers a set of AT commands to control the module.

2 Interfaces

Note:

Some of the WISMO interface signals are multiplexed in order to limit number of pins but this architecture implies some limitation.

For example, in case of using the SPI auxiliary bus, the General Purpose outputs GPO0 and GPO3 cannot be used.

 **Warning:**

All external signals must be inactive when the WISMO module is OFF to avoid any damage when starting and allow WISMO module to start correctly.

2.1 General Purpose Connector (GPC)

A 60-pin connector, with 0.5 mm pitch, is provided to interface the WISMO Quik Q24x6-C sub-series with a board containing either a keyboard, or a SIM connector, or a battery connection...

The interfaces available on the GPC are described in the next paragraphs.

The GPC is made by KYOCERA / AVX group with the following reference:

14 5087 060 930 861.

The matting connector has the following reference:

24 5087 060 X00 861.

For further details, refer to paragraph 4.4 General Purpose Connector data sheet.

2.2 Power supply

2.2.1 General description

The power supply is one of the key issues in the design of a GSM terminal. Due to the bursted emission in GSM / GPRS, the power supply must be able to deliver high current peaks in a short time. During these peaks the ripple (U_{ripp}) on the supply voltage must not exceed the limits specified in table "Power Supply Voltage" hereafter.

In communication mode, a GSM/GPRS class 2 terminal emits 577 μ s radio bursts every 4.615 ms.

In communication mode, a GPRS class 10 terminal emits 1154 μ s radio bursts every 4.615 ms.

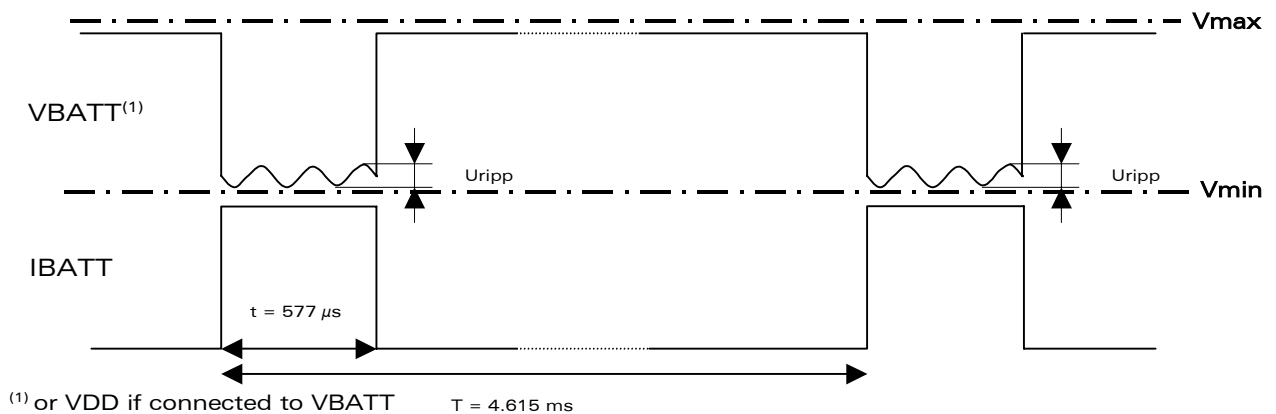

Figure 2: Typical power supply voltage in GSM mode

Two different inputs are provided for the power supply:

- the first one, VBATT, is used to supply the RF part,
- the second one, VDD, is used to supply the baseband part.

Notes:

- It is possible to connect VBATT to VDD.
- In case of separate power supplies, they have to be in the same state i.e both active or inactive at the same time.

VBATT: supplies directly the RF components with 3.6 V. It is essential to keep a minimum voltage ripple at this connection in order to avoid any phase error. The RF Power Amplifier current (2.0 A peak in GSM /GPRS mode with a 50 Ohms RF output) flows with a ratio of:

- 1/8 of the time (around 577 μ s every 4.615 ms for GSM/GPRS class 2),
- 2/8 of the time (around 1154 μ s every 4.615 ms for GSM/GPRS class 10).

The rising time is around 10 μ s.

VDD: supplies the +2.8 V ballast regulators of the WISMO QUIK Q24x6-C modules. It is essential to keep the voltage over 3.1 volts. The WISMO QUIK Q24x6-C Sub-series shielding case is the grounding. The ground has to be connected on the mother board through a complete layer on the PCB.

Power Supply Voltage

	V _{MIN}	V _{NOM}	V _{MAX}	Ripple max (U _{ripp})
VBATT	3.3 V (*)	3.6 V	4.5 V (**)	50 mVpp for freq<200 kHz 500 µVpp for freq>200 kHz
VDD	3.1 V		4.5 V	100 mVpp

(*): This value has to be guaranteed during the burst (with 2.0 A Peak in GSM or GPRS mode)

(**): Max operating Voltage Stationary Wave Ratio (VSWR) 2:1

Warning:

In case of power supply out of range, some "dysfunctions" can appear, then the module must be reset.

When supplying the module with a battery, the total impedance (battery+contacts+protections+PCB) should be < 150 mOhms to limit voltage drop-out within emission burst.

Refer to document [3] for further information about power supply design.

2.2.2 Power consumption

The following information is given assuming a 50 Ω RF output.

Power consumption in OFF mode (module supplied, OFF state, no software running)

	Conditions	I _{NOM}	I _{MAX}
Overall consumption VBATT + VDD	Off	5 µA	10 µA

**Power consumption
in E-GSM/GPRS 900 MHz and GSM/GPRS 850 MHz mode class 10**

	Conditions	I _{NOM}	I _{MAX}
VBATT	During TX bursts @Pcl5	1.6 A peak	1.8 A peak
VBATT	During RX bursts	110 mA peak	115 mA peak
VBATT	Average 1Rx/1Tx @Pcl5	250 mA	300 mA
VBATT	Average 1Rx/1Tx @Pcl8	190 mA	200 mA
VBATT	Average Idle mode	100 μ A	300 μ A
VBATT	Average GPRS CI 10 (3Rx/2Tx) @Pcl5	400 mA	510 mA
VBATT	Average GPRS CI 10 (3Rx/2Tx) @Pcl8	260 mA	300 mA
VDD	Average Idle mode	3 mA	7 mA

Power Control Level: Pcl5=2 W typ. ; Pcl8=0.5 W typ.

**Power consumption
in GSM/GPRS 1800 MHz and GSM/GPRS 1900 MHz mode class 10**

	Conditions	I _{NOM}	I _{MAX}
VBATT	During TX bursts @Pcl0	1 A peak	1.5 A peak
VBATT	During RX bursts	130 mA peak	140 mA peak
VBATT	Average 1Rx/1Tx @Pcl0	190 mA	235 mA
VBATT	Average 1Rx/1Tx @Pcl3	150 mA	180 mA
VBATT	Average Idle mode	100 μ A	300 μ A
VBATT	Average GPRS CI 10 (3Rx/2Tx) @Pcl0	320 mA	410 mA
VBATT	Average GPRS CI 10 (3Rx/2Tx) @Pcl3	240 mA	270 mA
VDD	Average Idle mode	2 mA	6.5 mA

Power Control Level: Pcl0=1 W typ.; Pcl3=0.25 W typ.

Power Supply Pinout

Signal	Pin number
+VBATT	55, 57, 58, 59 60
VDD	11
GND	Shielding

The ground connection is done through the shielding ⇒ the four legs have to be soldered to the ground plane.

2.3 Electrical information for digital I/O

All digital I/O comply with 3 Volts CMOS.

Operating conditions

Parameter	I/O type	Min	Max	Condition
V_{IL}	CMOS	-0.5 V	0.8 V	
V_{IH}	CMOS	2.1 V	3.0 V	
V_{OL}	1X		0.2 V	$I_{OL} = -1 \text{ mA}$
	2X		0.2 V	$I_{OL} = -2 \text{ mA}$
	3X		0.2 V	$I_{OL} = -3 \text{ mA}$
V_{OH}	1X	2.6 V		$I_{OH} = 1 \text{ mA}$
	2X	2.6 V		$I_{OH} = 2 \text{ mA}$
	3X	2.6 V		$I_{OH} = 3 \text{ mA}$

2.4 SPI bus

The SPI bus includes a clock signal (SPI_CLK), an I/O signal (SPI_IO) and an Enable signal (SPI_EN) complying with SPI bus standard.

Pin description

Signal	Pin number	I/O	I/O type	Description
SPI_CLK	10	O	1X	SPI Serial Clock
SPI_IO	8	I/O	CMOS / 1X	SPI Data
SPI_EN *	28	O	1X	SPI Enable

* Multiplexed with GPO3.

2.5 SPI Auxiliary bus

A second SPI Chip Enable (called SPI_AUX) has to be used to add a SPI peripheral to the WISMO Quik Q24x6-C Sub-series.

Pin description

Signal	Pin number	I/O	I/O type	Description
SPI_CLK	10	O	1X	SPI Serial Clock
SPI_IO	8	I/O	CMOS / 1X	SPI Data
SPI_AUX *	26	O	1X	SPI Aux. Enable

* Multiplexed with GPO0.

2.6 Keyboard interface

Warning :

This interface is not FULLY available with AT commands:

An AT command allows to get the input key code (see AT+CMER command description). This code has then to be processed by the application.

This interface provides 10 connections:

- 5 rows (ROW0 to ROW4),
- 5 columns (COL0 to COL4).

The scanning is a digital one, and the debouncing is done in the WISMO module. No discrete components like R, C (Resistor, Capacitor) are needed.

Pin description

Signal	Pin number	I/O	I/O type	Description
ROW0	13	I/O	CMOS / 1X	Row scan
ROW1	15	I/O	CMOS / 1X	Row scan
ROW2	17	I/O	CMOS / 1X	Row scan
ROW3	19	I/O	CMOS / 1X	Row scan
ROW4	21	I/O	CMOS / 1X	Row scan
COL0	23	I/O	CMOS / 1X	Column scan
COL1	25	I/O	CMOS / 1X	Column scan
COL2	27	I/O	CMOS / 1X	Column scan
COL3	29	I/O	CMOS / 1X	Column scan
COL4	31	I/O	CMOS / 1X	Column scan

2.7 Main serial link (UART1)

A flexible 6-wire serial interface is available complying with V24 protocol signaling but not with V28 (electrical interface) due to a 2.8 Volts interface.

The signals are:

- TX data (CT103/TX),
- RX data (CT104/RX),
- Request To Send (CT105/RTS),
- Clear To Send (CT106/CTS),
- Data Terminal Ready (CT108-2/DTR),
- Data Set Ready (CT107/DSR).

The 2 additional signals are Data Carrier Detect (CT109/DCD) and Ring Indicator (CT125/RI).

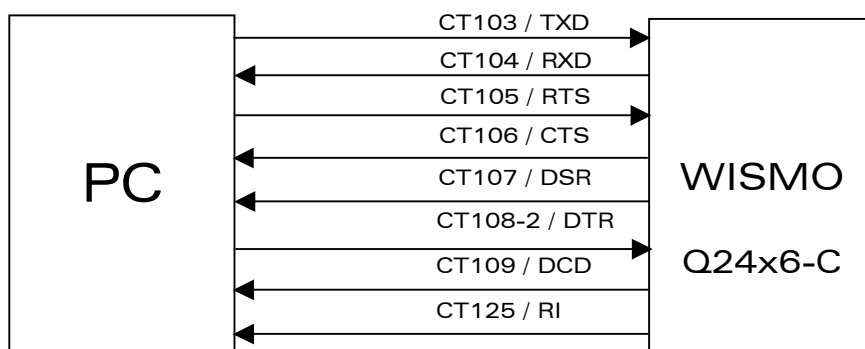

Figure 3: Serial Link signals for UART1

The set of serial link signals can be required for GSM DATA services application and is generated by the general purpose I/O provided by the WISMO module.

Note: the WISMO Quik Q24x6-C module is a DCE (Data Communication Equipment).

The Q24x6-C sub-series has been designed to allow a certain flexibility in the use of the serial interface signals. However, the use of TX, RX, CTS and RTS signals is mandatory which is not the case for DTR, DSR, DCD and RI signals which can be left disconnected if not used.

Pin description

Signal	Pin number	I/O	I/O type	Description
CT103/TXD1	39	I	CMOS	Transmit serial data
CT104/RXD1	32	O	1X	Receive serial data
CT105/RTS1	30	I	CMOS	Request To Send
CT106/CTS1	37	O	1X	Clear To Send
CT107/DSR1	36	O	1X	Data Set Ready
CT108-2/DTR1	34	I	CMOS	Data Terminal Ready
CT109/DCD1 *	51	O	CMOS / 2X	Data Carrier Detect
CT125/RI1 **	54	O	CMOS / 2X	Ring Indicator
CT102/GND	Shielding legs	-	-	Ground

* Multiplexed with GPIO3

** Multiplexed with GPIO2.

The rising time and falling time of the reception signals (mainly CT103) have to be less than 200 ns.

The Q24x6-C Sub-series have been designed to be operated using all the serial interface signals. In particular, it is necessary to use RTS and CTS signals for hardware flow control in order to avoid data corruption during transmission.

2.8 SIM interface

2.8.1 General Description

5 signals are available:

- SIM_VCC: SIM power supply.
- SIM_RST: reset.
- SIM_CLK: clock.
- SIM_DATA: I/O port.
- SIM_PRES: SIM card detect.

The SIM interface controls a 3 V SIM card (and a 5 V SIM card through an external SIM driver, refer to document [3] for more details).

This interface is fully compliant with GSM 11.11 recommendations concerning SIM functions.

Pin description

Signal	Pin number	I/O	I/O type	Description
SIM_CLK	3	O	2X	SIM Clock
SIM_RST	5	O	2X	SIM Reset
SIM_DATA	7	I/O	CMOS / 3X	SIM Data
SIM_VCC	9	O		SIM Power Supply
SIM_PRES	50	I	CMOS	SIM Card Detect

Electrical Characteristics

Parameter	Conditions	Min	Typ	Max	Unit
SIM_DATA V_{IH}	$I_{IH} = \pm 20 \mu A$	$0.7 \times SIM_VCC$			V
SIM_DATA V_{IL}	$I_{IL} = 1 \text{ mA}$			$0.3 \times SIM_VCC$	V
SIM_RST, SIM_DATA SIM_CLK V_{OH}	Source current = $20 \mu A$	$SIM_VCC - 0.1V$			V
SIM_RST, SIM_DATA SIM_CLK V_{OL}	Sink current = $-200 \mu A$			0.1	V
SIM_VCC* Output Voltage	$I_{SIMVCC} \leq 6 \text{ mA}$	2.70	2.80	2.85	V
SIM_CLK Rise/Fall Time	Loaded with 30 pF			50	ns
SIM_RST, SIM_DATA Rise/Fall Time	Loaded with 30 pF			1	μs
SIM_CLK Frequency	Loaded with 30 pF			3.25	MHz

(*): Given for a 3 V interface. An external SIM driver is needed to handle 5 V SIMs.

Note for SIM_PRES connection:

- When not used **SIM_PRES** has to be tied to VCC.
- When used, a low to high transition means that the SIM card is inserted and a high to low transition means that the SIM card is removed.

2.8.2 SIM 3/5V management

The WISMO Quik Q24x6-C Sub-series module is designed to interface with 3V SIMs only¹.

Nevertheless, it is possible to manage 3V and 5V SIMs using an external level shifter (refer to customer design guidelines [3]). In this case, depending on the type of SIM detected, the module firmware triggers the GPO0 output signal (pin #26) in order to properly set the external SIM driver level (3V or 5V).

¹ Most of the GSM operators have been providing 3V SIMs since 1998.

2.9 General Purpose Input/Output

The WISMO Quik Q24x6-C sub-series provides:

- 6 General Purpose I/O,
- 4 General Purpose Outputs,
- 1 General Purpose Input.

They are used to control any external devices.

Pin description

Signal	Pin number	I/O	I/O type	Description	Multiplexed with
GPI00	24	I/O	CMOS / 2X	General Purpose I/O	
GPI04	53	I/O	CMOS / 2X	General Purpose I/O	
GPI05	35	I/O	CMOS / 2X	General Purpose I/O	
GPO0	26	O	3X	General Purpose O	SPI_AUX
GPO1	22	O	3X	General Purpose O	
GPO2	20	O	3X	General Purpose O	
GPO3	28	O	3X	General Purpose O	SPI_EN
GPI	18	I	CMOS	General Purpose I	

2.10 Activity status indication

The activity status indication signal can be used to drive a LED through an open-collector transistor according to the module activity status.

LED status	WISMO Quik Q24x6-C Sub-series status	
OFF	Module in download mode or module OFF	
ON	Permanent	Module switched ON, not registered on the network
	Slow flash LED ON for 200 ms, OFF for 2 s	Module switched ON, registered on the network
	Quick flash LED ON for 200 ms, OFF for 600 ms	Module switched ON, registered on the network, communication in progress

Signal	Pin number	I/O	I/O type	Description
FLASH LED	52	O	2X	Activity status indication

2.11 Analog to Digital Converter (ADC)

Analog to Digital Converter is provided by the WISMO module. This converter is a 10-bit resolution, ranging from 0 to 2.8V.

Pin description

Signal	Pin number	I/O	I/O type	Description
AUXV0	33	I	Analog	A/D converter

Electrical Characteristics

Parameter	Min	Max	Unit
Resolution	10		bits
Sampling rate	90.3		Ksps/s
Input signal range	0	2.8V	V
ADC Reference Accuracy	0.75	2	%
Integral Accuracy	+/- 1	-	LSB
Differential Accuracy	+/- 1	-	LSB
Input Impedance (R)	10	-	MΩ
Input Impedance (C)	-	100	nF

2.12 Audio interface

Two different microphone inputs and two different speaker outputs are supported.

The WISMO Quik Q24x6-C Sub-series also includes an echo cancellation feature which allows hands-free function.

In some cases, ESD protection must be added on the audio interface lines.

2.12.1 Microphone inputs

The MIC2 inputs already include the biasing for an electret microphone allowing an easy connection to a handset.

The MIC1 inputs do not include an internal bias. MIC1/SPK1 is then appropriate for a hands-free system or a handset with biasing external to the module.

2.12.1.1 Common microphone inputs characteristics

The connection can be either differential or single-ended but using a differential connection in order to reject common mode noise and TDMA noise is strongly recommended.

When using a single-ended connection, be sure to have a very good ground plane, a very good filtering as well as shielding in order to avoid any disturbance on the audio path.

Internal audio filter characteristics

Frequency	Gain
0-150 Hz	< -22 dB
150-180 Hz	< -11 dB
180-200 Hz	< -3dB
200-3700 Hz	0 dB
>4000 Hz	< -60 dB

The gain of MIC inputs is internally adjusted and can be tuned from 30 dB to 51 dB using an AT command (refer to AT commands documentation [2]).

Microphone gain vs Max input voltage (using controller 1*)

Transmit Gain (dB)	Max Vin (mVrms)
+30	43.80
+33	31.01
+36	21.95
+39	15.54
+42	11
+45	7.79
+48	5.51
+51	3.9

(*) for more details, refer to AT commands documentation [2]

Microphone gain vs Max input voltage (using controller 2*)

Transmit Gain (dB)	Max Vin (mVrms)
- 6.5	3031
-6.0	2861
...	...
0.0	1434
...	...
+9.5	480
+10.0	454
+ 30.3	43.80
+ 30.8	41.36
...	...
+ 50.8	4.14
+ 51.3	3.90

(*) for more details, refer to AT commands documentation [2]

2.12.1.2 Main Microphone Inputs (MIC2)

The MIC2 inputs are differential ones. They already include the convenient biasing for an electret microphone (0.5 mA and 2 Volts). This electret microphone can be directly connected on these inputs.

The impedance of the microphone 2 has to be around 2 k Ω . These inputs are the standard ones for an handset design while MIC1 inputs can be connected to an external headset or a hands-free kit.

AC coupling is already embedded in the module.

Pin description

Signal	Pin #	I/O	I/O type	Description
MIC2P	46	I	Analog	Microphone 2 positive input
MIC2N	48	I	Analog	Microphone 2 negative input

2.12.1.3 Auxiliary Microphone Inputs (MIC1)

The MIC1 inputs are differential and do not include internal bias. To use these inputs with an electret microphone, bias has to be generated outside the WISMO Quik Q24x6-C Sub-series module according to the characteristics of this electret microphone. These inputs are the standard ones used for an external headset or a hands-free kit.

AC coupling is already embedded in the module.

Pin description

Signal	Pin #	I/O	I/O type	Description
MIC1P	42	I	Analog	Microphone 1 positive input
MIC1N	44	I	Analog	Microphone 1 negative input

2.12.2 Speaker outputs

2.12.2.1 Common speaker outputs characteristics

The connection can be differential or single-ended but using a differential connection to reject common mode noise and TDMA noise is strongly recommended. Moreover in single-ended mode, 1/2 of the power is lost. When using a single-ended connection, be sure to have a very good ground plane, a very good filtering as well as shielding in order to avoid any disturbance on the audio path.

Speaker outputs SPK1 and SPK2 are push-pull amplifiers and can be loaded down to 150 Ohms and up to 1 nF (see details in table *Speaker gain vs Max output voltage*).

Impedance of the speaker amplifier output in differential mode is:

$$R \leq 1\Omega \text{ +/-} 10\%$$

These outputs are differential and the output power can be adjusted by step of 2 dB. The output can be directly connected to a speaker.

Using a single-ended connection also includes losing half of the output power compared to a differential connection.

The gain of the speaker outputs is internally adjusted and can be tuned using an AT command (refer to AT commands documentation [2]).

Speaker gain vs Max output voltage

Receive Gain (dB) (*)	Max output level (Vrms)	Max.speaker load (Ω)
+2	1.74	150
0	1.38	50
-2	1.099	32
-4	0.873	32
-6	0.693	32
-8	0.551	32
-10	0.437	32
-12	0.347	32
-14	0.276	32
-16	0.219	32
-18	0.174	32
-20	0.138	32
-22	0.110	32
-24	0.087	32
-26	0.069	32

(*) analog gain: might not be significant

2.12.2.2 Speaker 2 Outputs

Pin description

Signal	Pin #	I/O	I/O type	Description
SPK2P	45	O	Analog	Speaker 2 positive output
SPK2N	47	O	Analog	Speaker 2 negative output

2.12.2.3 Speaker 1 Outputs

Pin description

Signal	Pin #	I/O	I/O type	Description
SPK1P	41	O	Analog	Speaker 1 positive output
SPK1N	43	O	Analog	Speaker 1 negative output

2.12.3 Buzzer Output

The buzzer output (BUZ) is a digital one. A buzzer can be directly connected between this output and VBATT. The maximum current is 80 mA (PEAK).

Pin description

Signal	Pin #	I/O	I/O type	Description
BUZ	49	O	Analog (open collector)	Buzzer output

Operating conditions

Parameter	Condition	Min	Max	Unit
V_{OL}	$I_{AVERAGE} = 40 \text{ mA}$		0.6	V
I_{PEAK}	$VBATT = VBATT_{max}$		80	mA
$I_{AVERAGE}$	$VBATT = VBATT_{max}$		40	mA

2.13 Battery charging interface

2.13.1 Hardware description

The WISMO module supports one battery charging circuit for Li-Ion batteries.

This circuit uses an interface which consists of a current source inputs (CHG_IN) where the constant current has to flow in order to charge the battery.

This current value depends on the battery capacity. It is recommended to provide a current equal to the value of the capacity plus 50 mA. For a 550 mA battery the current will be 600 mA. The maximum current is 800 mA.

A specific AT command (**AT+WBCM**), available from 4.3 level, allows to manage the battery charge (start and stop the charge, enable or disable unsolicited Battery Charge Indications and set the battery charge parameters).

The WISMO module monitors the battery voltage to detect the end of the charge.

The WISMO module also monitors the temperature of the battery through the BAT_TEMP pin which has to be connected to a temperature sensor inside the battery (a NTC resistor for instance).

Pin description

Signal	Pin number	I/O	I/O type	Description
CHG_IN	1, 2, 4	I	Supply	Current source input
BAT_TEMP	38	I	Analog	A/D converter

Electrical Characteristics

Parameter	Min	Max	Typ	Unit
BAT_TEMP resolution	10			bits
BAT_TEMP sampling rate	90.3			Ksps/s
BAT_TEMP Input Impedance (R)	4.7			k Ω
BAT_TEMP Input Impedance (C)		100		nF
CHG_IN Voltage (for I=I _{max})	5.1*	5.5		V
CHG_IN Current		800		mA
BAT_TEMP Input signal range			2.8	V _{pp}

* To be parametrized as per battery manufacturer

2.13.2 Li-ion charging procedure

A constant current source has to be provided through **CHG_IN** inputs in order to charge the Li-ion battery, and **BAT_TEMP** input has to be connected to a battery temperature sensor. During this procedure the voltage of the battery is accurately monitored.

The Li-ion charging involves two phases:

- During the first phase, the battery is charged with a constant current until its voltage reaches 4.1 V* ,
- During the second phase, the constant current is pulsed by the module. The width and the frequency of the pulse change during this phase in order to ensure a safety charge.

The battery is considered as fully charged when, after a pulse, the voltage remains at a 4.1 V* during more than 10 s.

The Li-ion battery must have an included safety circuit to avoid any discharge or overcharge. This circuit is delivered by the manufacturer inside the battery pack. The impedance of this safety circuit has to be the lowest possible in order to reduce the drop-out of the voltage. This drop-out is due to the RF Power Amplifier current (up to 2.0 A). A maximum of 150 mΩ is required.

(*): To be parametrized as per battery manufacturer

2.14 ON / ~OFF

2.14.1 General description

This input is used to switch ON or OFF the WISMO module.

A high level signal has to be provided on the pin ON/~OFF to switch ON the module.

The level of the voltage of this signal has to be maintained between 2.4 V and VDD during a minimum of 1 s.

This signal can be left at high level until switch OFF.

To be able to switch OFF the module, the pin ON/~OFF has to be released. Through the firmware, the module can be switched OFF (using the AT+CPOF command).

Pin description

Signal	Pin number	I/O	I/O type	Description
ON/~OFF	6	I	CMOS	Module Power ON/OFF

Electrical Characteristics

Parameter	Min	Max	Unit
Input Impedance (R)	10		k Ω
Input Impedance (C)		50	pF

Operating conditions

Parameter	I/O type	Min	Max	Unit
V _{IL}		0 V	0.6 V	V
V _{IH}		2.4 V	VDD+0.5 V	V

2.14.2 Operating sequences

2.14.2.1 Power ON

Once the module is supplied by the power source, the application must set the ON/~OFF signal to high to start the module power ON sequence.

The ON/~OFF signal must be held for 1 s minimum. After this time, an internal mechanism keeps it on hold. During the power ON sequence, an internal reset is automatically performed by the module for 240 ms (typical). During this phase, any external reset should be avoided.

Once the initialisation is complete (timing is SIM and network dependent) the AT interface answers « OK » to the application². For further details, please refer to the AT commands documentation (AT+WIND, AT+WAIP)

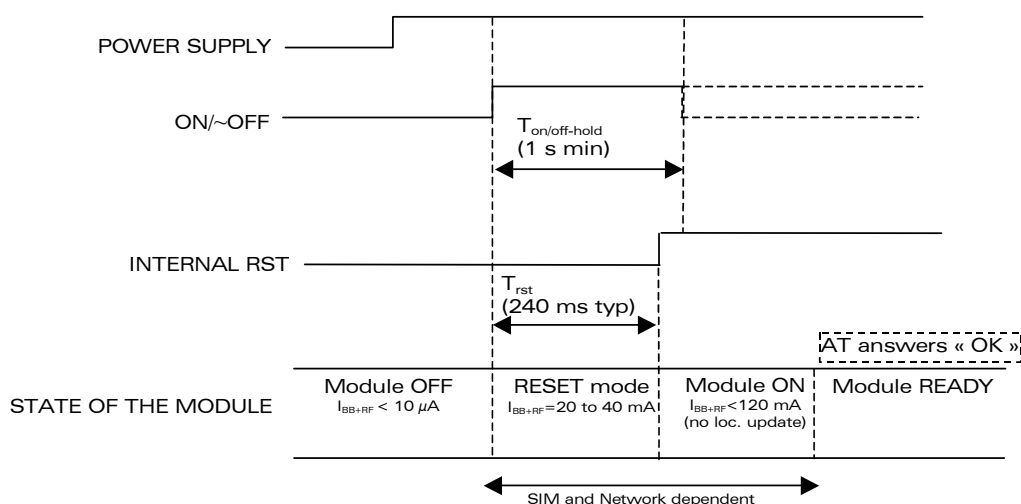

I_{BB+RF} = overall current consumption (Base Band + RF part)

Figure 4: Power-ON sequence diagram (no PIN code activated)

² For this, the application has to send AT.J. If the application manages hardware flow control, the AT command can be sent during the initialisation phase. Another solution is to use the AT+WIND command to get an unsolicited status from the module.

2.14.2.2 Power OFF

To properly power OFF the module, the application must set the ON/~OFF signal to low and then send the AT+CPOF command to de-register from the network and switch off the module. Once the « OK » response is issued by the module, the power supply can be switched off.

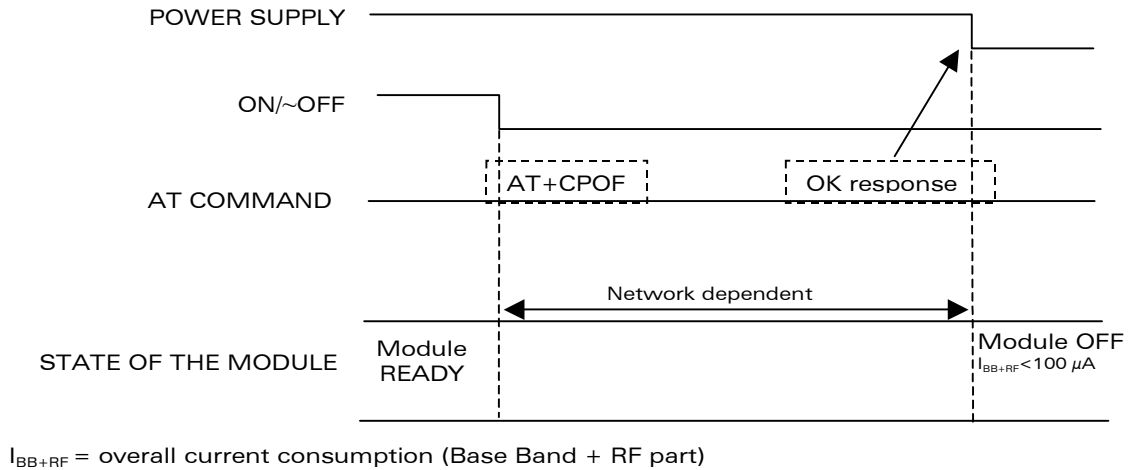

Figure 5: Power-OFF sequence diagram

2.15 BOOT (optional)

This input can be used to download a software in the Flash memory of the WISMO module.

For the applications based on AT commands, this is a backup download procedure only (refer to document [3] Customer Design Guidelines).

The internal boot procedure is started when this pin is low during the reset of the module.

In normal mode this pin has to be left open. In Internal boot mode, low level has to be set through a 1 kΩ resistor. If used, this input has to be driven by an open collector or an open drain output:

- BOOT pin 12 = 0, for download mode,
- BOOT pin 12 = 1, for normal mode.

Pin description

Signal	Pin number	I/O	I/O type	Description
BOOT	12	I	CMOS	Flash Downloading

Note: The nominal firmware download procedure is using the X-modem.

2.16 Reset signal (~RST)

2.16.1 General description

This signal is used to force a reset procedure by providing low level during at least 500 μ s.

This signal has to be considered as an emergency reset only. A reset procedure is automatically driven by an internal hardware during the power-up sequence.

This signal can also be used to provide a reset to an external device. It then behaves as an output. If no external reset is necessary this input can be left open. If used (emergency reset), it has to be driven by an open collector or an open drain output:

- ~RST pin 14 = 0, for Module Reset,
- ~RST pin 14 = 1, for normal mode.

Pin description

Signal	Pin number	I/O	I/O type	Description
~RST	14	I/O	SCHMITT	Module Reset

Electrical Characteristics

Parameter	Min	Max	Unit
Input Impedance (R)	4.7		k Ω
Input Impedance (C)		10	nF

Operating conditions

Parameter	Min	Max	Condition
*V _{T-}	1.1 V	1.2 V	
*V _{T+}	1.7 V	1.9 V	
V _{OL}		0.4 V	I _{OL} = -50 μ A
V _{OH}	2.0 V		I _{OH} = 50 μ A

* V_{T-}, V_{T+}: Hysteresis thresholds

Additional comments on RESET:

The RESET process is activated either by the external ~RST signal or by an internal signal (coming from a RESET generator). This automatic reset is activated at Power-up.

The module remains in RESET mode as long as the ~RST signal is held low.

This signal should be used only for "emergency" resets.

A software reset is always preferred to a hardware reset.

2.16.2 Reset sequence

To activate the « emergency » reset sequence, the ~RST signal has to be set to low for 500 μs minimum.

As soon as the reset is complete, the AT interface answers « OK » to the application. For this, the application has to send AT↵. If the application manages hardware flow control, the AT command can be sent during the initialisation phase. Another solution is to use the AT+WIND command to get an unsolicited status from the module.

For further details, refer to AT commands documentation [2].

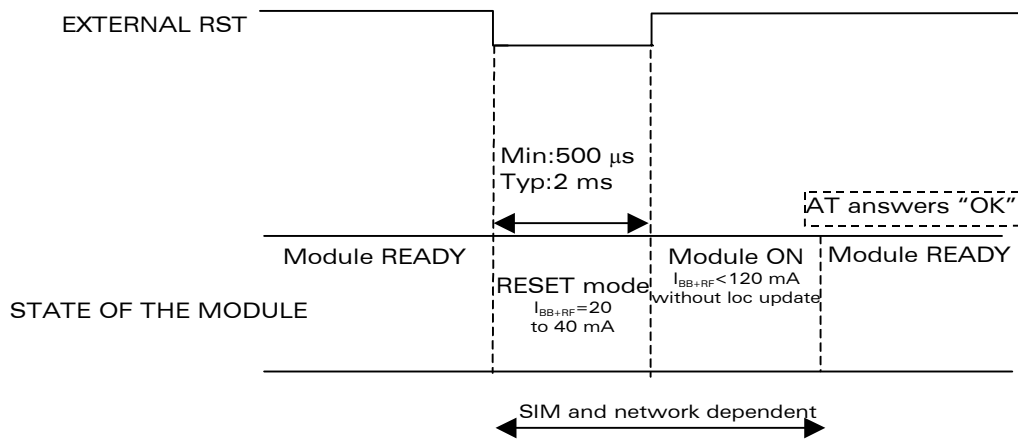

Figure 6: Reset sequence diagram

2.17 External Interrupt (~INTR)

The WISMO module provides an external interrupt input ~INTR. This input is very sensitive and an interrupt is activated on high to low edge. If this signal is not used, it can be left open. If used, this input has to be driven by an open collector or an open drain output.

This input is used for instance to power OFF automatically the module.

Pin description

Signal	Pin number	I/O	I/O type	Description
~INTR	16	I	CMOS	External Interrupt

Electrical characteristics

Parameter	Min	Max	Unit
V _{IL}	-0.5	0.7	Volt
V _{IH}	2.2	3.0	Volt

2.18 VCC output

This output can be used to power some external functions. VCC has to be used as a digital power supply. This power supply is available when the module is ON.

Pin description

Signal	Pin number	I/O	I/O type	Description
VCC	40	O	Supply	Digital supply

Operating conditions

Parameter	Condition	Min	Max	Unit
Output voltage	I = 10 mA	2.74	2.86	V
Output Current			10	mA

2.19 Real Time Clock Supply (VCC_RTC)

VCC_RTC input is used to provide a back-up power supply for the internal Real Time Clock. The RTC is supported by the module when powered on but a back-up power supply is needed to save date and time information when the module is switched off.

If the RTC is not used, this pin can be left open.

Pin description

Signal	Pin number	I/O	I/O type	Description
VCC_RTC	56	I/O	Supply	RTC Back-up supply

Operating conditions

Parameter	Condition	Min	Max	Unit
Input voltage		2	2.75	V
Input Current	VCC=0 V; t° = +25 °C VCC_RTC=2.5 V		3	μA
Input Current	VCC=0 V; t°:-20 °C / +55 °C VCC_RTC=2.5 V		10	μA
Output voltage		2.4	2.75	V
Output current			2	mA

2.20 RF interface

The impedance is 50 Ohms nominal and the DC impedance is 0 Ohm.

The RF connection between the WISMO Quik Q24x6-C sub-series module and the customer application is made by the RADIALL coaxial connector type MMS.

The MMS connector stands on three pliable legs.

This design guarantees the receptacle stability after the placement.

The MMS snap-on mating system ensures a correct positive connection each time.

Multi-sourcing cable assemblies are available (refer to part references and suppliers in document [3]).

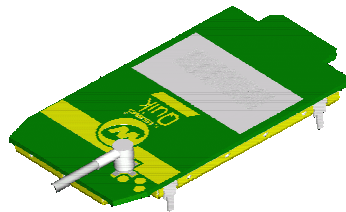

Notes:

- The WISMO Quik Q24x6-C Sub-series does not include any antenna switch for a car kit but this function can be implemented externally and it can be driven using a GPIO.
- The antenna cable and connector should be chosen in order to minimize losses in the frequency bands used for GSM 850/E-GSM 900 MHz and DCS1800/PCS 1900 MHz.
- 0.5 dB can be considered as a maximum value for loss between the module and an external connector.

2.20.1 RF performances

RF performances are compliant with the ETSI recommendation GSM 05.05.

The main parameters for Receiver are:

- GSM850 Reference Sensitivity (Q2426-C) = -104 dBm Static & TUHigh
- E-GSM900 Reference Sensitivity (Q2406-C) = -104 dBm Static & TUHigh
- DCS1800 Reference Sensitivity (Q2406-C) = -104 dBm Static & TUHigh
- PCS1900 Reference Sensitivity (Q2426-C) = -104 dBm Static & TUHigh
- Selectivity @ 200 kHz: > +9 dBc
- Selectivity @ 400 kHz: > +41 dBc
- Linear dynamic range: 63 dB
- Co-channel rejection: >= 9 dBc

And for Transmitter:

- Maximum output power (E-GSM900 & GSM850): 33 dBm +/- 2 dB at ambient temperature.

- Maximum output power (DCS1800 & PCS1900): 30 dBm +/- 2 dB at ambient temperature.
- Minimum output power (E-GSM900 & GSM850): 5 dBm +/- 5 dB at ambient temperature.
- Minimum output power (DCS1800 & PCS1900): 0 dBm +/- 5 dB at ambient temperature.

2.20.2 Antenna specifications

The antenna must fulfill the following requirements.

Frequency depends on application. A dual-band antenna shall work in these frequency bands and have the following characteristics:

Characteristic	Q2406-C		Q2426-C	
	E-GSM 900	DCS 1800	GSM 850	PCS 1900
Frequency TX	880 to 915 MHz	1710 to 1785 MHz	824 to 849 MHz	1850 to 1910 MHz
Frequency RX	925 to 960 MHz	1805 to 1880 MHz	869 to 894 MHz	1930 to 1990 MHz
Impedance	50 Ohms			
VSWR	Rx max	1.5 : 1		
	Tx max	1.5 : 1		
Typical radiated gain	0 dBi in one direction at least			

Note: Wavecom recommends a VSWR max. of 1.5:1 for the Rx and the Tx. All aspects of this specification will be fulfilled even with a VSWR max. of 2:1 for the Rx and the Tx.

3 Technical specifications

3.1 General Purpose Connector pin out description

Pin #	Name	I/O	I/O type	Description	Comment
1	CHG_IN	I	Supply	Supply for battery charging	High current
2	CHG_IN	I	Supply	Supply for battery charging	High current
3	SIM_CLK	O	2 X	Clock for SIM interface	
4	CHG_IN	I	Supply	Supply for battery charging	High current
5	SIM_RST	O	2 X	Reset for SIM interface	
6	ON/~OFF	I	CMOS	Power ON/OFF control	
7	SIM_DATA	I/O	CMOS / 3X	I/O for SIM interface	
8	SDA/SPI_IO	I/O	CMOS/1X	Wire interface or SPI Serial Data	
9	SIM_VCC	O	Supply	SIM card supply	6 mA max
10	SCL/SPI_CLK	O	1X	Wire interface or SPI Serial clock	
11	VDD	I	Supply	Low power supply	3.1 V minimum or connected to VBATT
12	BOOT	I	CMOS	BOOT	Pull down through 1 K Ω for Flash downloading
13	ROW0	I/O	CMOS/1X	Keyboard Row	
14	~RST	I/O	SCHMITT	Module Reset	Active low
15	ROW1	I/O	CMOS/1X	Keyboard Row	
16	~INTR	I	CMOS	External interrupt	Active low. 100 k Ω Pull-up inside
17	ROW2	I/O	CMOS/1X	Keyboard Row	
18	GPI	I	CMOS	General Purpose Input	100 k Ω Pull-down inside

Pin #	Name	I/O	I/O type	Description	Comment
19	ROW3	I/O	CMOS/1X	Keyboard Row	
20	GPO2	O	3X	General Purpose Output	
21	ROW4	I/O	CMOS/1X	Keyboard Row	
22	GPO1	O	3X	General Purpose Output	
23	COL0	I/O	CMOS/1X	Keyboard Column	
24	GPIO0	I/O	CMOS/2X	General Purpose I/O	
25	COL1	I/O	CMOS/1X	Keyboard Column	
26	GPO0 or SPI_AUX	O	3X	General Purpose Output or SPI Aux Or SIM 3V / 5V	Multiplexed
27	COL2	I/O	CMOS/1X	Keyboard Column	
28	SPI_EN or GPO3	O	3X	SPI enable or General Purpose Output	Multiplexed
29	COL3	I/O	CMOS/1X	Keyboard Column	
30	CT105/RTS1	I	CMOS	Serial link interface Request To Send (UART1)	Pull up to VCC with 100 k Ω when not used
31	COL4	I/O	CMOS/1X	Keyboard Column	
32	CT104/RXD1	O	1X	Serial link interface Receive (UART1)	
33	AUXV0	I	Analog	Auxiliary ADC input 0	Can be tied to GND if not used
34	CT108-2/DTR1	I	CMOS	Serial link interface Data Terminal Ready (UART1)	Pull up to VCC with 100 k Ω when not used
35	GPIO5	I/O	CMOS / 2X	General Purpose I/O	
36	CT107/DSR1	O	1X	Serial link interface Data Set Ready (UART1)	
37	CT106/CTS1	O	1X	Serial link interface Clear To Send (UART1)	
38	BAT_TEMP	I	Analog	ADC input for battery temperature measurement	Can be tied to GND if not used

Pin #	Name	I/O	I/O type	Description	Comment
39	CT103/TXD1	I	CMOS	Serial link interface Transmit (UART1)	Pull up to VCC with 100 k Ω when not used
40	VCC	O	Supply	2.8 V digital supply output	10 mA max.
41	SPK1P	O	Analog	Speaker 1 positive output	
42	MIC1P	I	Analog	Microphone 1 positive input	
43	SPK1N	O	Analog	Speaker 1 negative output	
44	MIC1N	I	Analog	Microphone 1 negative input	
45	SPK2P	O	Analog	Speaker 2 positive output	
46	MIC2P	I	Analog	Microphone 2 positive input	
47	SPK2N	O	Analog	Speaker 2 negative output	
48	MIC2N	I	Analog	Microphone 2 negative input	
49	BUZ	O	Analog	Buzzer output	80 mA max
50	SIM_PRES	I	CMOS	SIM Card Detect	
51	CT109/DCD1	O	CMOS/2X	Serial interface Data Carrier Detect (UART1)	
52	FLASH LED	O	2X	Activity status indication	
53	GPIO4	I/O	CMOS/2X	General Purpose I/O	
54	CT125 / RI1	O	CMOS/2X	Serial interface Ring Indicator (UART1)	
55	+VBATT		Supply	Battery Input	High current
56	VCC_RTC	I/O	Supply	RTC back-up supply	
57	+VBATT		Supply	Battery Input	High current
58	+VBATT		Supply	Battery Input	High current
59	+VBATT		Supply	Battery Input	High current
60	+VBATT		Supply	Battery Input	High current

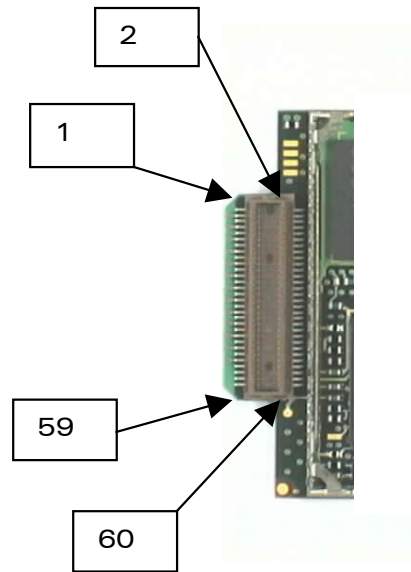

Figure 7: WISMO Quik Q24x6-C sub-series pin position (bottom view)

3.2 Environmental Specifications

3.2.1 Operational conditions of functioning

Conditions	Temperature range
Operating / Class A	-20 °C to +55 °C for GSM 850 / 900 -10 °C to +55 °C for GSM 1800 / 1900
Operating / Class B	-30 °C to +70 °C
Operating / Class C	-40 °C to +85 °C
Storage	-40 °C to +85 °C

Function Status Classification:

- Class A:** The module shall have full function during and after an external influence. The GSM performance shall meet the minimum ETSI requirements.
- Class B:** Any functions can be out of specified tolerances. All the functions will be going back to normal tolerances automatically after that the external influence has been removed. Performance is allowed to go outside of the minimum ETSI requirements, but It must be possible to connect a call and send a SMS.
- Class C:** The functional requirements will not be fulfilled during external influence, but will return to full function automatically after that the external influence has been removed.

3.2.2 Environmental qualification

Test Designation	Standards	Definition / Severities
Resistance to Heat	IEC 60068-2-2	Temperature: +85°C Duration: 504 h
Resistance to cold test	IEC 60068-2-30 Db	Storage temperature: -40±2 °C Storage time: 72 h
Cooking Test	-	Temperature: +70 ±2°C Duration: 100 days
Damp heat test	IEC 60068-2-3	Storage temperature: +40±2°C Storage humidity: 95±3% Storage time: 21 days
Damp heat cycle test	IEC 60068-2-30 Db	Upper temperature: +55±2°C Number of cycles: 10
Temperature change	IEC 60068-2-14 Nb	Low temperature: -40±2°C High temperature: +85±2°C Total duration: 11 days
Thermal Shock	IEC 60068-2-14	Low temperature: -40±2°C High temperature: +85±2°C Total duration: 200 hours
Resistance to sinusoidal vibration	IEC 60068-2-6 Fc	[10 Hz to 16 Hz]: ±5 mm (peak) [16 Hz to 62 Hz]: 5 g (peak) [62 Hz to 200Hz]: 3g (peak) [200 Hz to 1000 Hz] 1g (peak) Test duration: 20 cycles Sweep directions: X / Y / Z
Resistance to random vibration	IEC 60068-2-64	Frequency range: 10 Hz - 2000 Hz Spectrum level: 0.1 g ² /Hz at 10 Hz 0.01 g ² /Hz at 250 Hz 0.0005 g ² /Hz at 1000 Hz 0.0005 g ² /Hz at 2000 Hz Duration: 16 h Vibration axis: X / Y / Z
Resistance to mechanical shock	IEC 68-2-27	Peak acceleration: 30g / 100g / 200g Direction: ±X, ±Y, ±Z
ESD Test	IEC 1000-4-2	1 kV contact discharge on 60-pin connector 2 kV contact discharge on RF connector

For more details refer to document [1]:
 "Automotive Environmental Control Plan For Wismo Quik Q24XX-C"

3.3 Mechanical specifications

3.3.1 Physical characteristics

The WISMO Quik Q24x6-C Series module has a complete self-contained shield.

- Dimensions: 58.4 x 32.2 x 6.2 external dimensions (except shielding pins and RF connector)
- Weight: <12 g

3.3.2 Mechanical drawings

The next page gives the mechanical specifications of WISMO Quik Q24x6-C Series.

MAXIMUM BULK OCCUPIED ON THE MOTHER BOARD

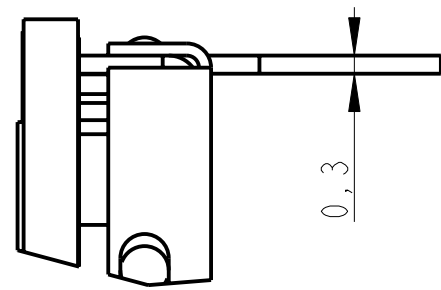
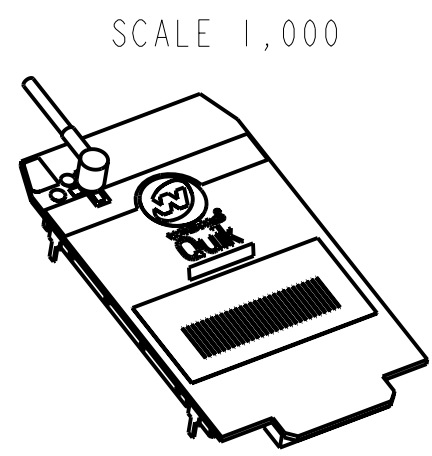

9,1±0,5
3,9^{+0,35}_{-0,20}
5,2±0,2(TBC)

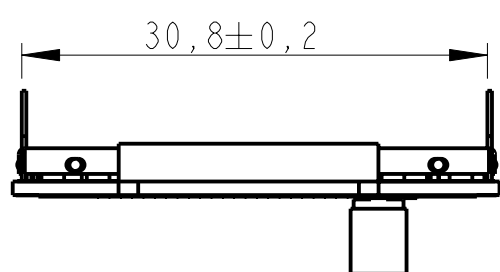
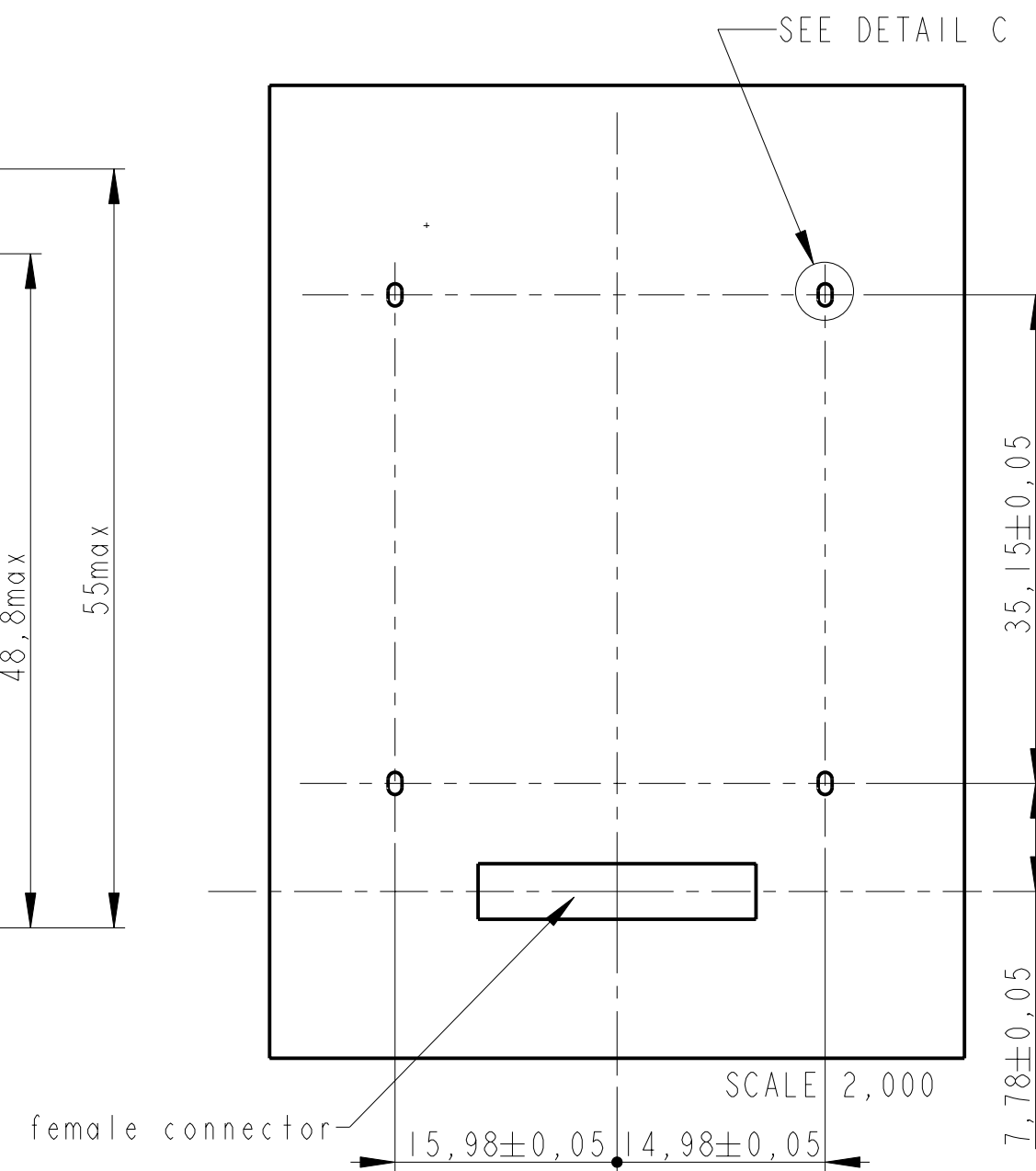
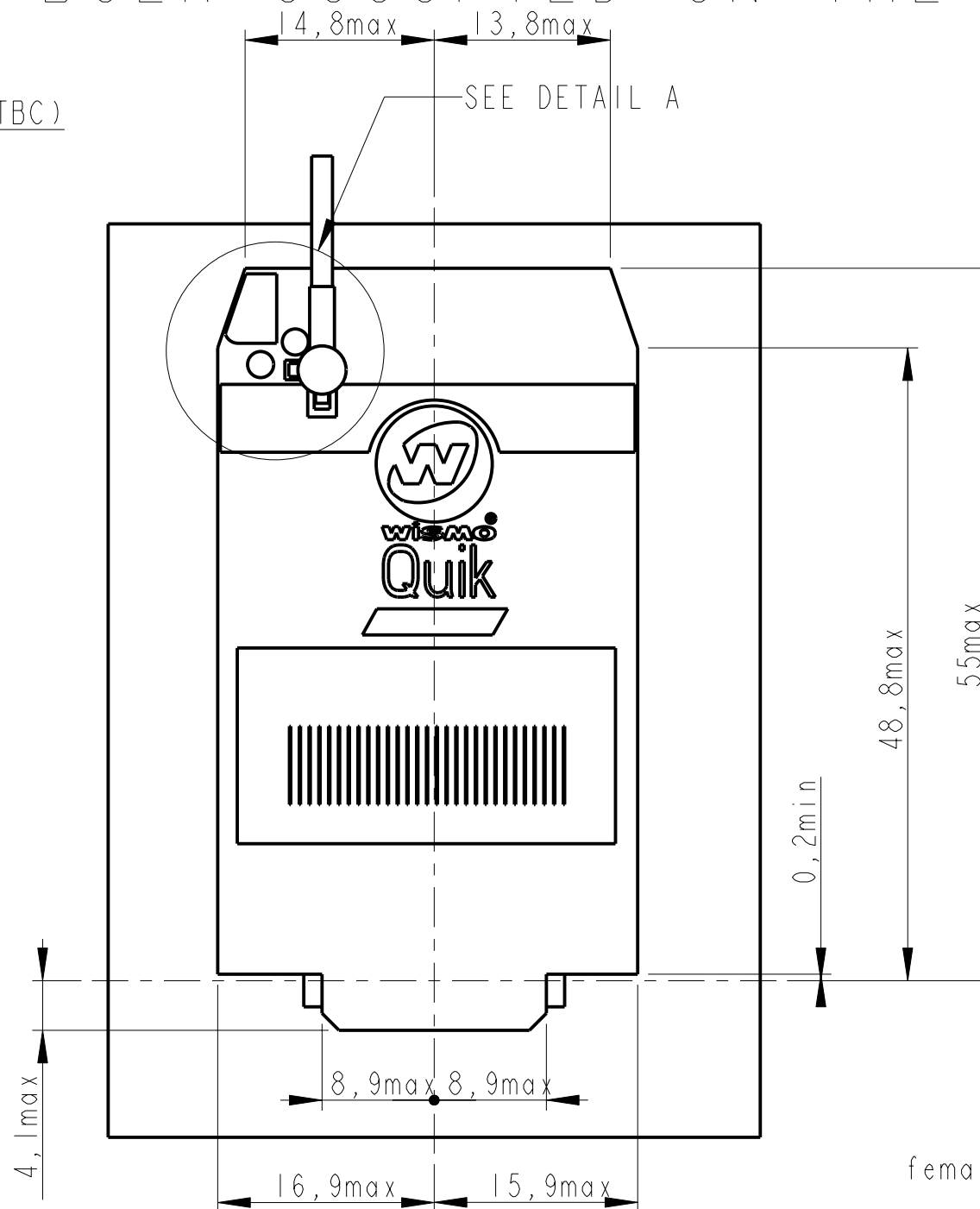
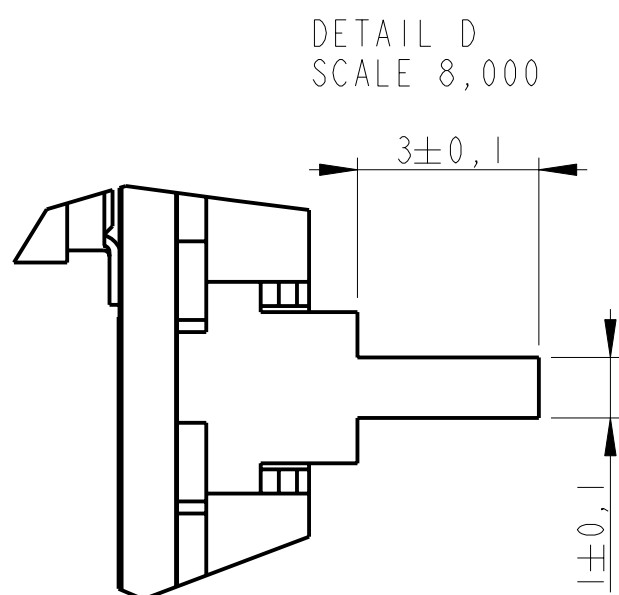
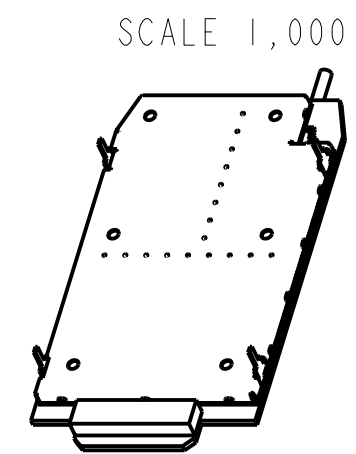

30,1±0,2
28±0,2
SEE DETAIL B

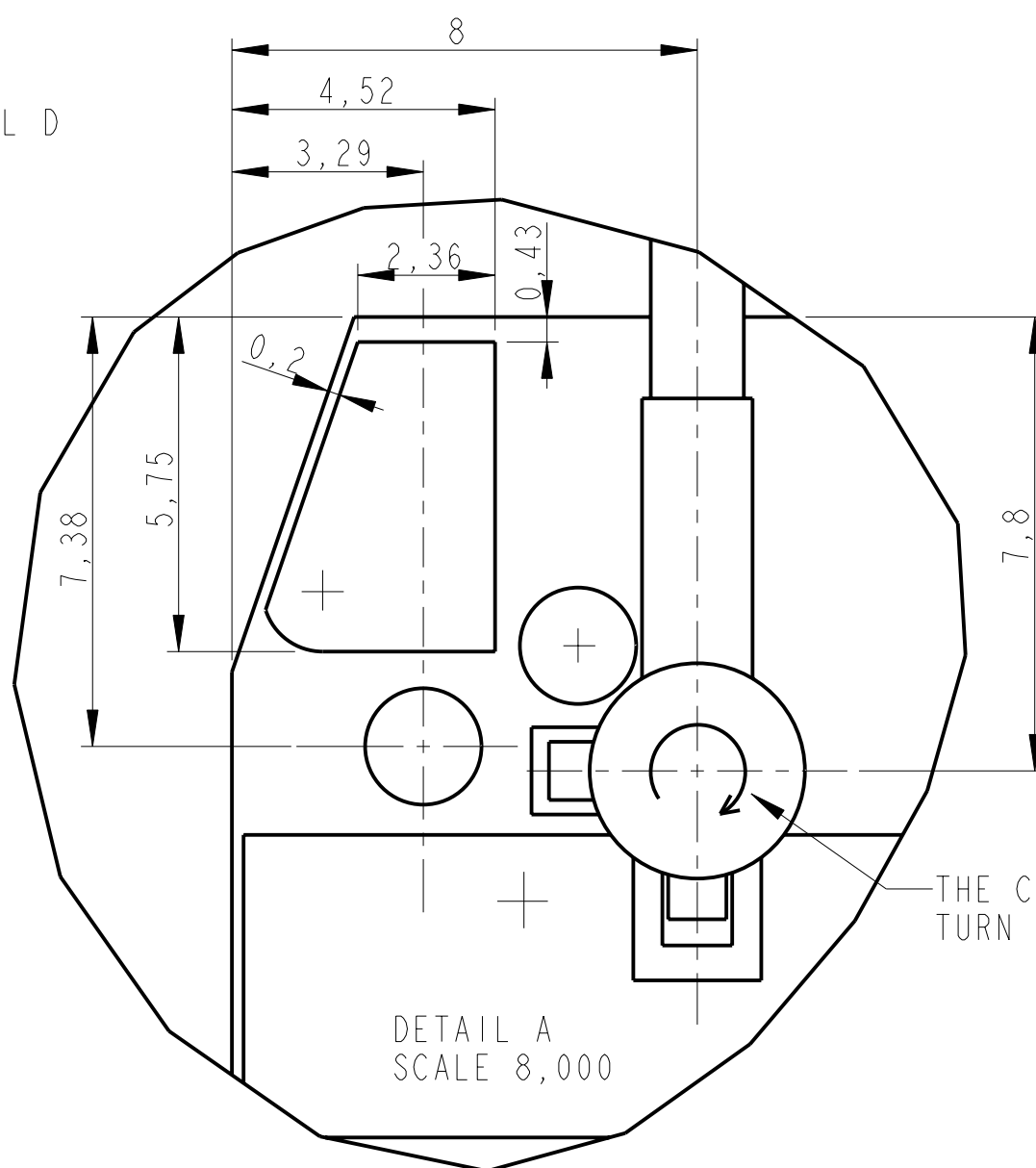
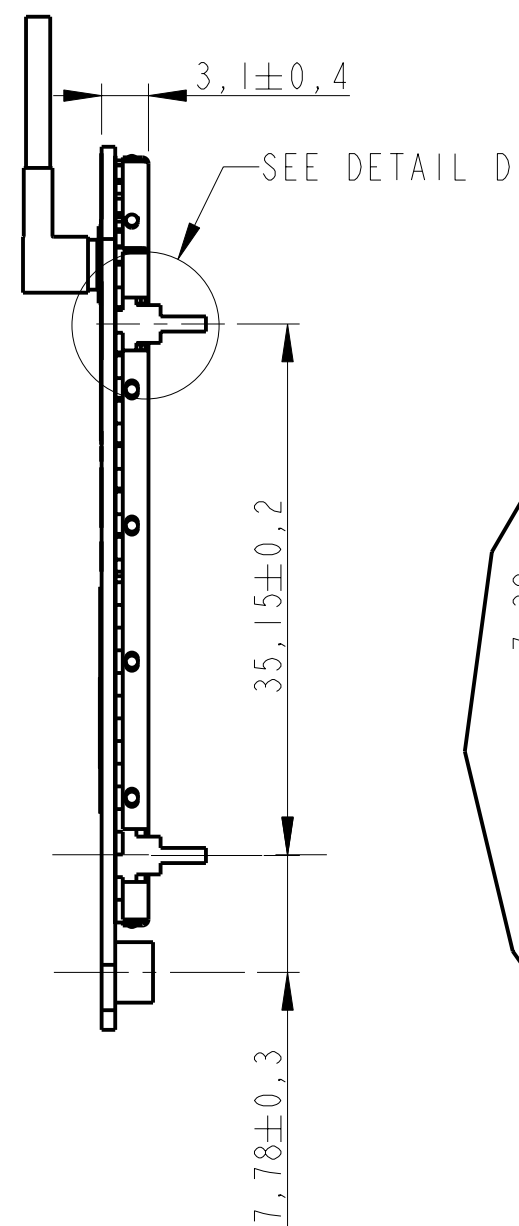
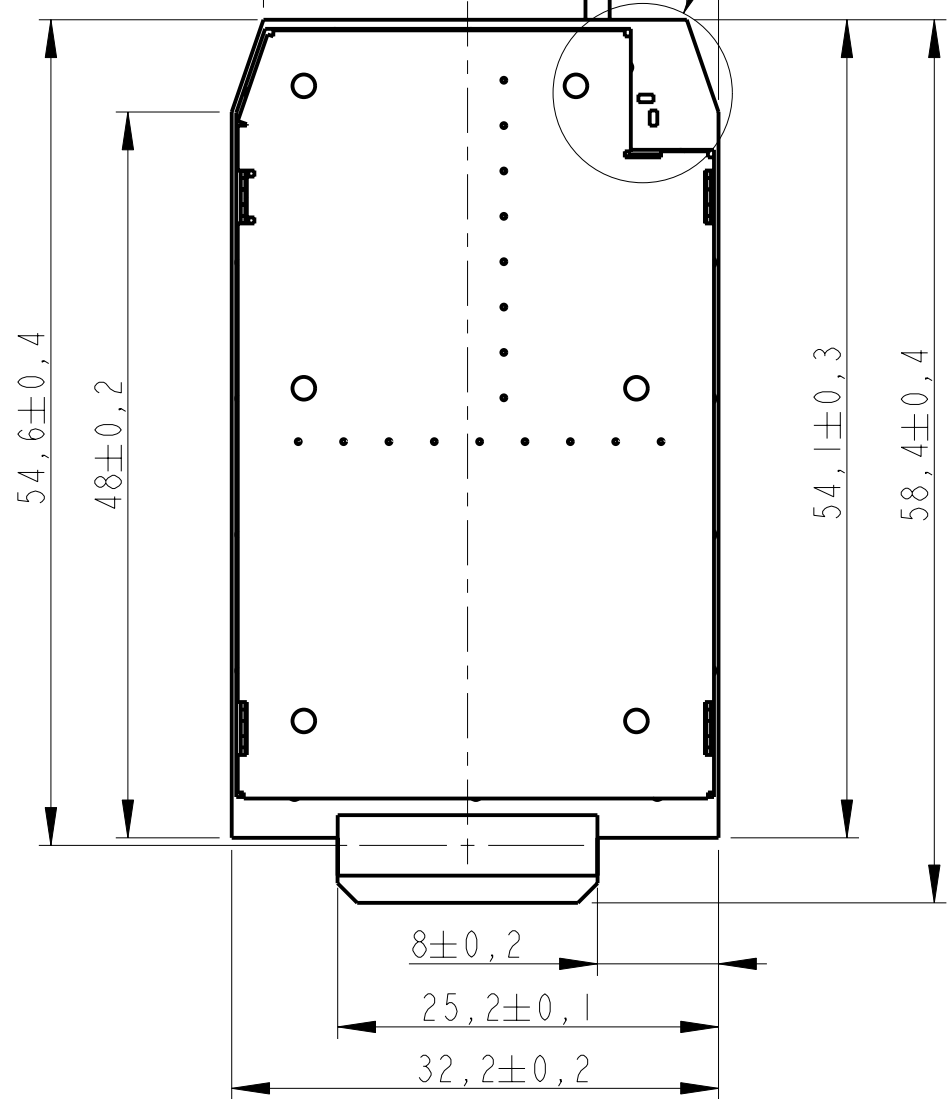

THE CABLE CAN TURN ON 360 DEGREES

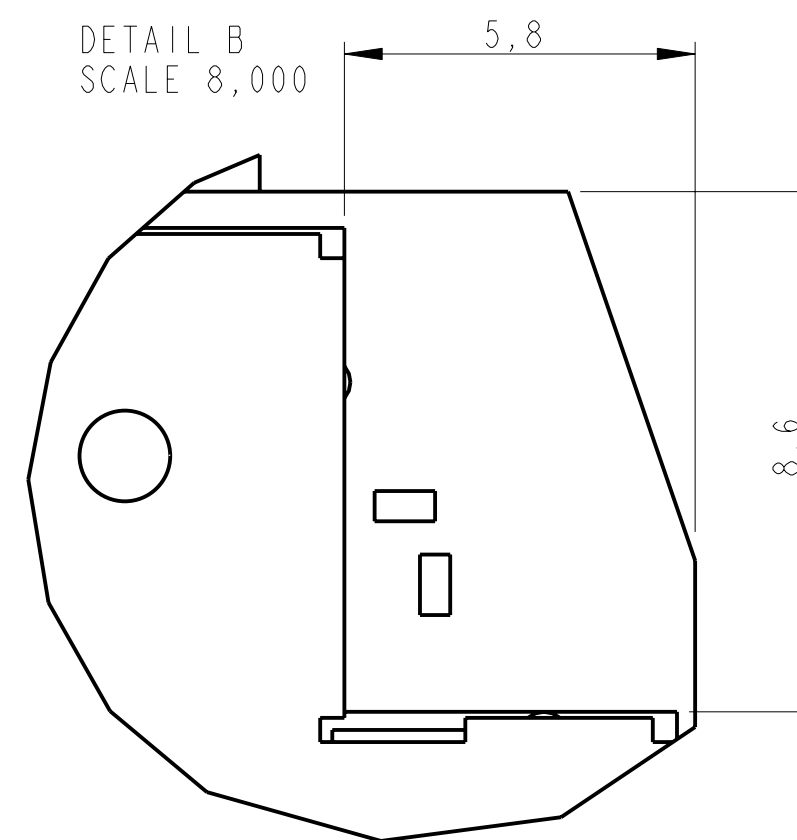

Tol. modif.	07/10/03	JPM	HER	Prototypes	04
gnd modif.	07/07/03	JPM	HER	Prototypes	03
Tol. update	24/04/03	JPM	HER	Prototypes	02
Creation	26/11/02	JPM	JJO	Prototypes	01
MODIFICATION	DATE	AUTHOR	RESP.	STATUS	IND

Wismo 2D10-C		TOL.GEN.: ±0,2	SCALE 2,000
MODULE DIMENSIONS		FOLIO: 1/1	FORMAT: A2
wavecom		WM-2-2173-V-001-A	
PRO/ENGINEER		AUTEUR: JPM	04
WM2D10C_DIMENSIONS		RESPONS: HER	IND.

4 Appendix

4.1 Wavecom acceptance test

The WISMO Quik Q24x6-C sub-series complies with Wavecom standard acceptance test plan (Refer to document [1]).

4.2 GSM Standard and Recommendations

The WISMO Quik Q24x6-C sub-series is compliant with the following GSM ETSI, 3GPP, GCF and NAPRD03 recommendations for Phase II.

Specification Reference	Title
3GPP TS 45.005 v5.5.0 (2002-08) Release 5	Technical Specification Group GSM/EDGE. Radio Access Network; Radio transmission and reception
GSM 02.07 V8.0.0 (1999-07)	Digital cellular telecommunications system (Phase 2+); Mobile Stations (MS) features (GSM 02.07 version 8.0.0 Release 1999)
GSM 02.60 V8.1.0 (1999-07)	Digital cellular telecommunications system (Phase 2+); General Packet Radio Service (GPRS); Service description, Stage 1 (GSM 02.60 version 8.1.0 Release 1999)
GSM 03.60 V7.9.0 (2002-09)	Technical Specification Group Services and System Aspects; Digital cellular telecommunications system (Phase 2+); General Packet Radio Service (GPRS); Service description; Stage 2 (Release 1998)
3GPP TS 43.064 V5.0.0 (2002-04)	Technical Specification Group GERAN; Digital cellular telecommunications system (Phase 2+); General Packet Radio Service (GPRS); Overall description of the GPRS radio interface; Stage 2 (Release 5)
3GPP TS 03.22 V8.7.0 (2002-08)	Technical Specification Group GSM/EDGE. Radio Access Network; Functions related to Mobile Station (MS) in idle mode and group receive mode; (Release 1999)
3GPP TS 03.40 V7.5.0 (2001-12)	Technical Specification Group Terminals; Technical realization of the Short Message Service (SMS) (Release 1998)
3GPP TS 03.41 V7.4.0	Technical Specification Group Terminals; Technical

Specification Reference	Title
(2000-09)	realization of Cell Broadcast Service (CBS) (Release 1998)
ETSI EN 300 903 V8.1.1 (2000-11)	Digital cellular telecommunications system (Phase 2+); Transmission planning aspects of the speech service in the GSM Public Land Mobile Network (PLMN) system (GSM 03.50 version 8.1.1 Release 1999)
3GPP TS 04.06 V8.2.1 (2002-05)	Technical Specification Group GSM/EDGE Radio Access Network; Mobile Station - Base Station System (MS - BSS) interface; Data Link (DL) layer specification (Release 1999)
3GPP TS 04.08 V7.18.0 (2002-09)	Technical Specification Group Core Network; Digital cellular telecommunications system (Phase 2+); Mobile radio interface layer 3 specification (Release 1998)
3GPP TS 04.10 V7.1.0 (2001-12)	Technical Specification Group Core Networks; Mobile radio interface layer 3 Supplementary services specification; General aspects (Release 1998)
3GPP TS 04.11 V7.1.0 (2000-09)	Technical Specification Group Core Network; Digital cellular telecommunications system (Phase 2+); Point-to-Point (PP) Short Message Service (SMS) support on mobile radio interface (Release 1998)
3GPP TS 45.005 v5.5.0 (2002-08)	Technical Specification Group GSM/EDGE. Radio Access Network; Radio transmission and reception (Release 5)
3GPP TS 45.008 V5.8.0 (2002-08)	Technical Specification Group GSM/EDGE Radio Access Network; Radio subsystem link control (Release 5)
3GPP TS 45.010 V5.1.0 (2002-08)	Technical Specification Group GSM/EDGE Radio Access Network; Radio subsystem synchronization (Release 5)
3GPP TS 46.010 V5.0.0 (2002-06)	Technical Specification Group Services and System Aspects; Full rate speech; Transcoding (Release 5)
3GPP TS 46.011 V5.0.0 (2002-06)	Technical Specification Group Services and System Aspects; Full rate speech; Substitution and muting of lost frames for full rate speech channels (Release 5)
3GPP TS 46.012 V5.0.0	Technical Specification Group Services and System

Specification Reference	Title
(2002-06)	Aspects; Full rate speech; Comfort noise aspect for full rate speech traffic channels (Release 5)
3GPP TS 46.031 V5.0.0 (2002-06)	Technical Specification Group Services and System Aspects; Full rate speech; Discontinuous Transmission (DTX) for full rate speech traffic channels (Release 5)
3GPP TS 46.032 V5.0.0 (2002-06)	Technical Specification Group Services and System Aspects; Full rate speech; Voice Activity Detector (VAD) for full rate speech traffic channels (Release 5)
TS 100 913V8.0.0 (1999-08)	Digital cellular telecommunications system (Phase 2+); General on Terminal Adaptation Functions (TAF) for Mobile Stations (MS) (GSM 07.01 version 8.0.0 Release 1999)
GSM 09.07 V8.0.0 (1999-08)	Digital cellular telecommunications system (Phase 2+); General requirements on interworking between the Public Land Mobile Network (PLMN) and the Integrated Services Digital Network (ISDN) or Public Switched Telephone Network (PSTN) (GSM 09.07 version 8.0.0 Release 1999)
3GPP TS 51.010-1 v5.0.0 (2002-09)	Technical Specification Group GSM/EDGE ; Radio Access Network ;Digital cellular telecommunications system (Phase 2+);Mobile Station (MS) conformance specification; Part 1: Conformance specification (Release 5)
3GPP TS 51.011 V5.0.0 (2001-12)	Technical Specification Group Terminals; Specification of the Subscriber Identity Module - Mobile Equipment (SIM - ME) interface (Release 5)
ETS 300 641 (1998-03)	Digital cellular telecommunications system (Phase 2); Specification of the 3 Volt Subscriber Identity Module - Mobile Equipment (SIM-ME) interface (GSM 11.12 version 4.3.1)
GCF-CC V3.7.1 (2002-08)	Global Certification Forum – Certification criteria
NAPRD03 V2.6.0 (2002-06)	North America Permanent Reference Document for PTCRB tests

4.3 Safety recommendations (for information only)

IMPORTANT
FOR THE EFFICIENT AND SAFE OPERATION OF
YOUR GSM APPLICATION BASED ON WISMO Quik Q24x6-C sub-series
PLEASE READ THIS INFORMATION CAREFULLY

4.3.1 RF safety

4.3.1.1 General

Your application using the WISMO Quik Q24x6-C module is based on the GSM standard for cellular technology. The GSM standard is spread all over the world. It covers Europe, Asia and some parts of America and Africa. This is the most used telecommunication standard.

Your GSM terminal is actually a low power radio transmitter and receiver. It sends out and receives radio frequency energy. When you use your GSM application, the cellular system which handles your calls controls both the radio frequency and the power level of your cellular modem.

4.3.1.2 Exposure to RF energy

There has been some public concern about possible health effects of using GSM terminals.

Although research on health effects from RF energy has focused on the current RF technology for many years, scientists have begun research regarding newer radio technologies, such as GSM.

After existing research had been reviewed, and after compliance to all applicable safety standards had been tested, it has been concluded that the product was fitted for use.

If you are concerned about exposure to RF energy there are things you can do to minimize exposure. Obviously, limiting the duration of your calls will reduce your exposure to RF energy. In addition, you can reduce RF exposure by operating your cellular terminal efficiently by following the below guidelines.

4.3.1.3 Efficient terminal operation

For your GSM terminal to operate at the lowest power level, consistent with satisfactory call quality:

- If your terminal has an extendible antenna, extend it fully. Some models allow you to place a call with the antenna retracted. However your GSM terminal operates more efficiently with the antenna fully extended.
- Do not hold the antenna when the terminal is « IN USE ». Holding the antenna affects call quality and may cause the modem to operate at a higher power level than needed.

4.3.1.4 Antenna care and replacement

Do not use the GSM terminal with a damaged antenna. If a damaged antenna comes into contact with the skin, a minor burn may result. Replace a damaged antenna immediately. Consult your manual to see if you may change the antenna yourself. If so, use only a manufacturer-approved antenna. Otherwise, have your antenna repaired by a qualified technician.

Use only the supplied or approved antenna. Unauthorized antennas, modifications or attachments could damage the terminal and may contravene local RF emission regulations or invalidate type approval.

4.3.2 General safety

4.3.2.1 Driving

Check the laws and the regulations regarding the use of cellular devices in the area where you have to drive as you always have to comply with them. When using your GSM terminal while driving, please:

- give full attention to driving,
- pull off the road and park before making or answering a call if driving conditions so require.

4.3.2.2 Electronic devices

Most electronic equipment, for example in hospitals and motor vehicles, is shielded from RF energy. However RF energy may affect some improperly shielded electronic equipment.

4.3.2.3 Vehicle electronic equipment

Check your vehicle manufacturer representative to determine if any on-board electronic equipment is adequately shielded from RF energy.

4.3.2.4 Medical electronic equipment

Consult the manufacturer of any personal medical devices (such as pacemakers, hearing aids, etc...) to determine if they are adequately shielded from external RF energy.

Turn your terminal **OFF** in health care facilities when any regulations posted in the area instruct you to do so. Hospitals or health care facilities may be using RF monitoring equipment.

4.3.2.5 Aircraft

Turn your terminal OFF before boarding any aircraft.

Use it on the ground only with crew permission.

Do not use it in the air.

To prevent possible interference with aircraft systems, Federal Aviation Administration (FAA) regulations require you to have permission from a crew member to use your terminal while the aircraft is on the ground. To prevent interference with cellular systems, local RF regulations prohibit using your modem while airborne.

4.3.2.6 Children

Do not allow children to play with your GSM terminal. It is not a toy. Children could hurt themselves or others (by poking themselves or others in the eye with the antenna, for example). Children could damage the modem, or make calls that increase your modem bills.

4.3.2.7 Blasting areas

To avoid interfering with blasting operations, turn your unit OFF when in a « blasting area » or in areas posted: « turn off two-way radio ». Construction crew often use remote control RF devices to set off explosives.

4.3.2.8 Potentially explosive atmospheres

Turn your terminal **OFF** when in any area with a potentially explosive atmosphere. It is rare, but your modem or its accessories could generate sparks. Sparks in such areas could cause an explosion or fire resulting in bodily injuries or even death.

Areas with a potentially explosive atmosphere are often, but not always, clearly marked. They include fuelling areas such as petrol stations; below decks on boats; fuel or chemical transfer or storage facilities; and areas where the air contains chemicals or particles, such as grain, dust, or metal powders.

Do not transport or store flammable gas, liquid, or explosives, in the compartment of your vehicle which contains your terminal or accessories.

Before using your terminal in a vehicle powered by liquefied petroleum gas (such as propane or butane) ensure that the vehicle complies with the relevant fire and safety regulations of the country in which the vehicle is to be used.

4.4 General Purpose Connector data sheet

The next 6 pages are the KYOCERA/ELCO data sheets for the GPC (also available from <http://www.avxcorp.com> .

0,5 mm Spacing

SERIES 5087

Surface Mount Vertical Plug

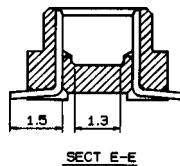
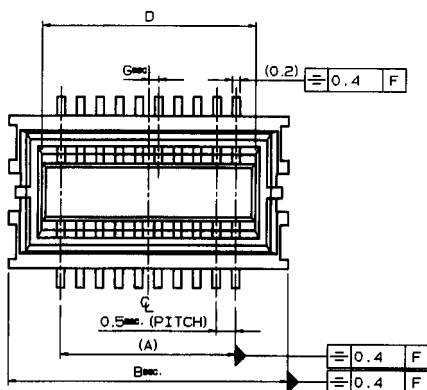

Specifications:

- 1000 per Tape and Reel
- Voltage - 50 V
- Current Rating - 0.4 A
- Dielectric Withstanding Voltage - 500 V
- Operating Temperature - (-25°C ~ +85°C)
- Contact Material - phosphor bronze
- Insulator Material - PPS (UL 94 V-0)

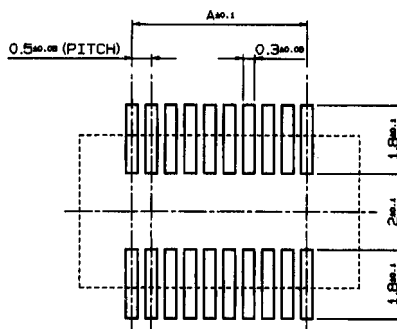
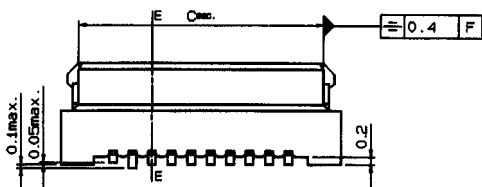

MOUNTING LAYOUT

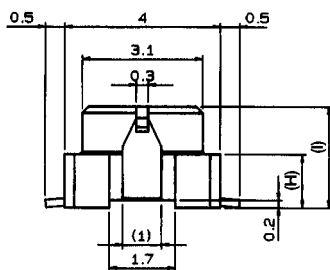

No. of Pos.	P/N	A	B	C	D	G
20	10 5087 020 XX0 861	4.5/.177	7.2/.283	6.2/.244	5.5/.217	0.25/.0098
30	10 5087 030 XX0 861	7.0/.276	9.7/.382	8.7/.343	8.0/.315	0.50/.0196
36	10 5087 036 XX0 861	8.5/.335	11.2/.441	10.2/.402	9.5/.374	0.25/.0098
40	10 5087 040 XX0 861	9.5/.374	12.2/.480	11.2/.441	10.5/.414	0.25/.0098
50	10 5087 050 XX0 861	12.0/.472	14.7/.579	13.7/.539	13.0/.512	0.50/.0196
60	10 5087 060 XX0 861	14.5/.571	17.2/.677	16.2/.638	15.5/.610	0.25/.0098

Dimensions millimeters/inches

ORDERING CODE

Typical Example

14

5087

0XX

2XX

861

14: PLUG - Tape and Reel

NUMBER OF CONTACTS:

40, 60 : 3.0mm Stack

36, 40, 50 : 3.5mm Stack

20, 30, 36,

50, 60 : 4.0mm Stack

2: Without Adhesive Tape

9: Adhesive Cover Tape

VARIATION CODE:

30 H .9 I 2.15

35 1.4 2.7

40 1.9 3.2

PLATING VARIATION:

861: 15 microinches of gold with gold flash tails

Consult factory for other sizes

Surface Mount Vertical Receptacle

Specifications:

- 1000 per Tape and Reel
- Voltage - 50 V
- Current Rating - 0.4 A
- Dielectric Withstanding Voltage - 500 V
- Operating Temperature - (-25°C ~ +85°C)
- Contact Material - phosphor bronze
- Insulator Material - PPS (UL 94 V-0)

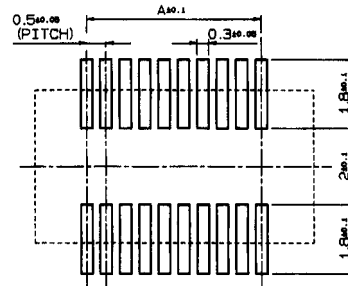
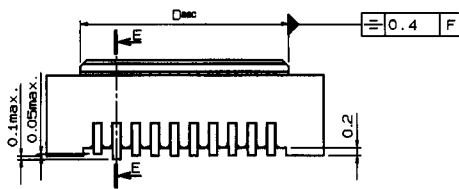
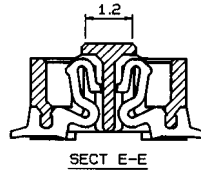
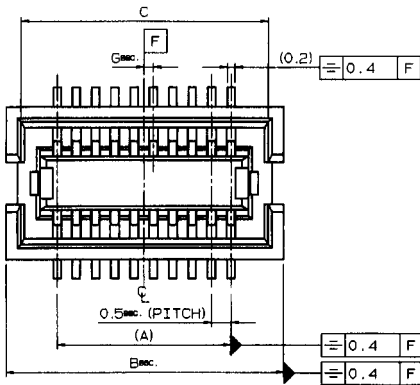

MOUNTING LAYOUT

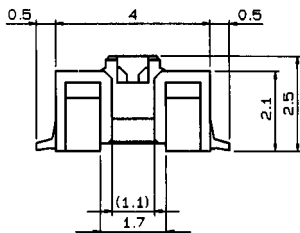

No. of Pos.	P/N	A	B	C	D	G
20	20 5087 020 x00 861	4.5/.177	7.2/.283	6.4/.252	5.4/.213	0.25/.0098
30	20 5087 030 x00 861	7.0/.276	9.7/.382	8.9/.350	7.9/.311	0.50/.0196
36	20 5087 036 x00 861	8.5/.335	11.2/.441	10.4/.409	9.4/.370	0.25/.0098
40	20 5087 040 x00 861	9.5/.374	12.2/.480	11.4/.449	10.4/.409	0.25/.0098
50	20 5087 050 x00 861	12.0/.472	14.7/.579	13.9/.547	12.9/.508	0.50/.0196
60	20 5087 060 x00 861	14.5/.570	17.2/.677	16.4/.646	15.4/.606	0.25/.0098

Dimensions millimeters/inches

ORDERING CODE

Typical Example

24

5087

0XX

200

861

24: Receptacle - Tape and Reel

NUMBER OF CONTACTS:

20, 30, 36, 40, 50, 60

2: Without Adhesive Tape

9: Adhesive Cover Tape

PLATING VARIATION:

861: 15 microinches of gold with gold flash tails

Consult factory for other sizes

0,5 mm Spacing

Applications

	P/N	Stacking Height
PLUG	10 5087 xxx x30 861	3.0
RECE.	20 5087 xxx x00 861	
PLUG	10 5087 xxx x35 861	3.5
RECE.	20 5087 xxx x00 861	
PLUG	10 5087 xxx x40 861	4.0
RECE.	20 5087 xxx x00 861	

No. of Pos.	A
20	7.2/283
30	9.7/382
36	11.2/441
40	12.2/480
50	14.7/579
60	17.2/677

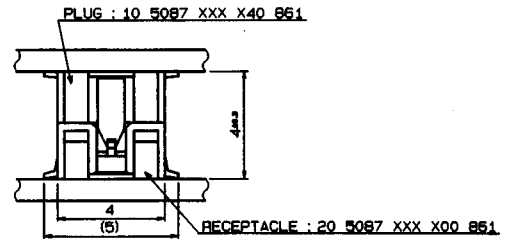
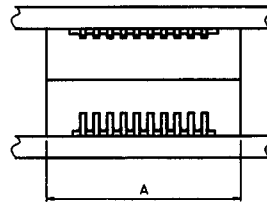
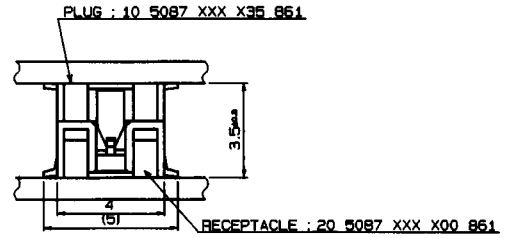
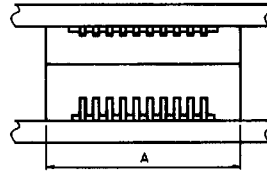
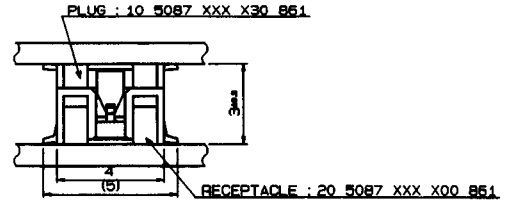
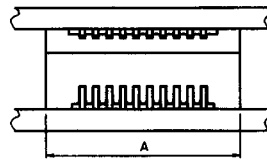

0,5 mm Spacing

Tape and Reel

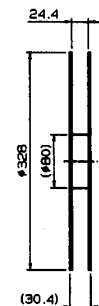
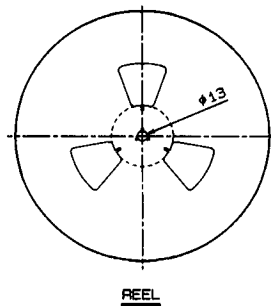
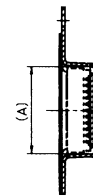
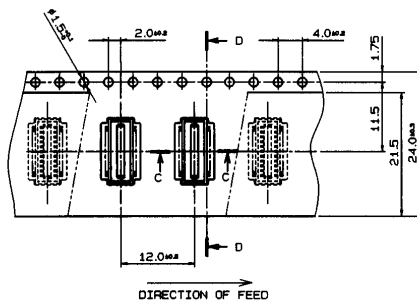

Super Micro Connectors 0.5mm Pitch

Series 5087 Plug

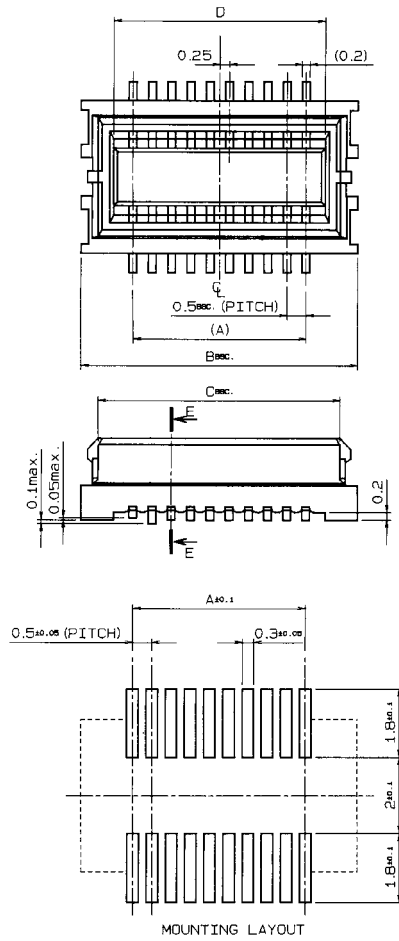

ORDERING CODE

14 5087 0XX X XX 8XX

- FINISH
 - 861 = Ni Under Coated
1.25µm min.
Gold-Mating Area
Au 0.38µm min.
 - 829 = Ni Under Coated
1.25µm min.
Gold-Mating Area
Au 0.1µm min.
- VARIATION
 - 30 : H = 3.0mm
 - 35 : H = 3.5mm
 - 40 : H = 4.0mm
- TYPE
 - 0 = without Boss with Retention Clip
 - 2 = without Boss, Retention Clip
 - 9 = without Boss, Retention Clip, with Adhesive Tape
- NUMBER OF POSITIONS (20, 30, 32, 36, 40, 50, 60)
- SERIES
- TAPE AND REEL
14 = Plug

H = 3.0mm Type

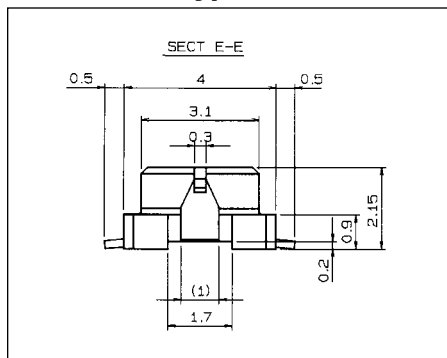

H = 3.5mm Type

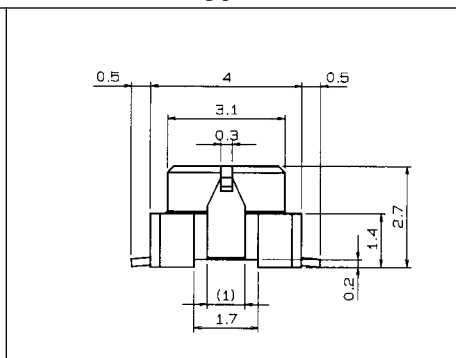

H = 4.0mm Type

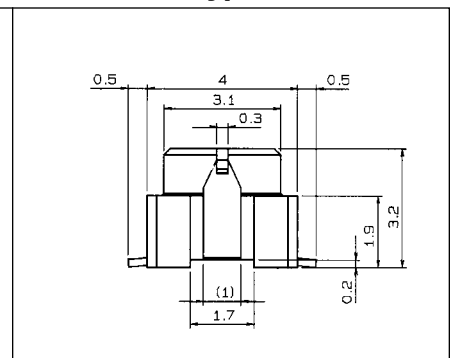

Additional information on this product is available from AVX's catalog or AVX's FAX Service. Call 1-800-879-1613 and request document #269. Visit our website <http://www.avxcorp.com>

ELCO

Super Micro Connectors 0.5mm Pitch

Series 5087 Receptacle H = 3.0 ~ 4.0mm Type

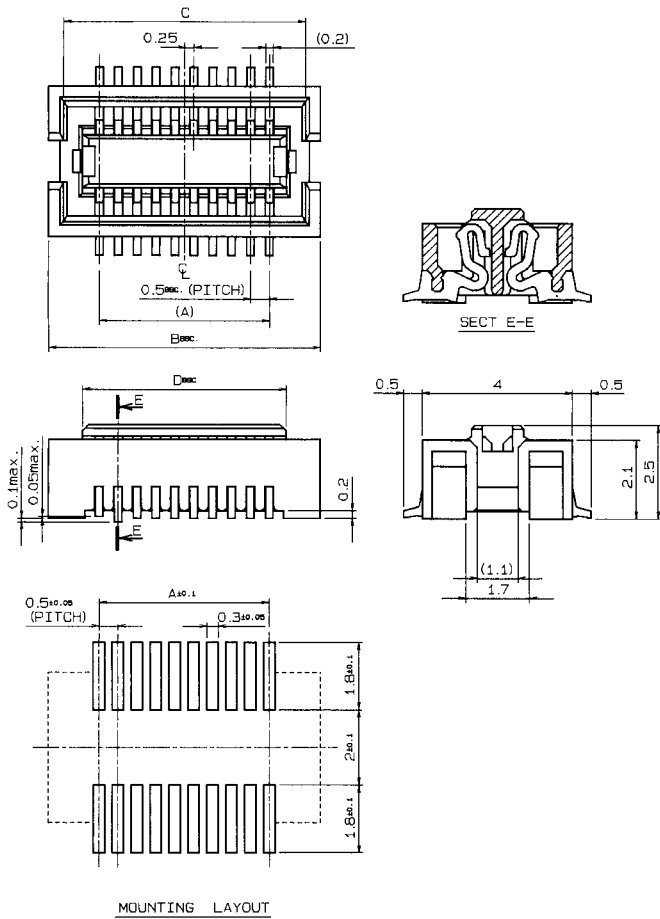

ORDERING CODE

24 **5087** **0XX** **X** **00** **8XX**
 — FINISH
 861 = Ni Under Coated
 1.25µm min.
 Gold-Mating Area
 Au 0.38µm min.
 829 = Ni Under Coated
 1.25µm min.
 Gold-Mating Area
 Au 0.1µm min.
 — VARIATION
 H = 3.0 ~ 4.0mm
 — TYPE 0 = without Boss with Retention Clip
 2 = without Boss, Retention Clip
 9 = without Boss, Retention Clip, with Adhesive Tape
 — NUMBER OF POSITIONS
 (20, 30, 32, 36, 40, 50, 60)
 — SERIES
 — TAPE AND REEL
 24 = Receptacle

A = 0.5 (± -1)
 B = A + 2.7
 C = A + 1.9
 D = A + 0.9

Additional information on this product is available from AVX's catalog or AVX's FAX Service. Call 1-800-879-1613 and request document #270. Visit our website <http://www.avxcorp.com>

Super Micro Connectors 0.5mm Pitch

Series 5087 Plug

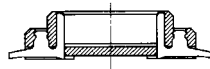
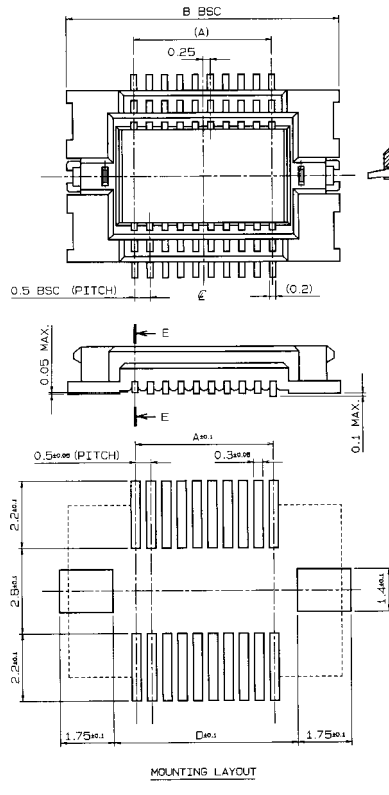

H = 2.0mm Type

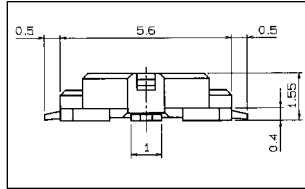

H = 2.5mm Type

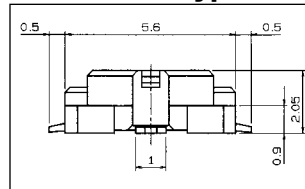

A = 0.5 (±0.1)
 B = 0.5 (±0.1)+4.4
 D = 0.5 (±0.1)+1.5

ORDERING CODE

14 5087 0XX X XX 8XX

FINISH
 861 = Ni Under Coated
 1.25µm min.
 Gold-Mating Area
 Au 0.38µm min.
 829 = Ni Under Coated
 1.25µm min.
 Gold-Mating Area
 Au 0.1µm min.

VARIATION
 20 : H = 2.0mm
 25 : H = 2.5mm

TYPE 0 = without Boss with Retention Clip
 2 = without Boss, Retention Clip
 9 = without Boss, Retention Clip, with Adhesive Tape

NUMBER OF POSITIONS
 (10*, 20, 30, 40, 50, 60) *2.0mm H only

SERIES
 TAPE AND REEL
 14 = Plug

Series 5087 Receptacle H = 2.0 ~ 2.5mm Type

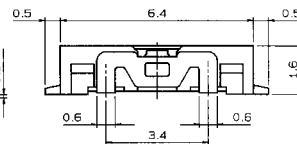
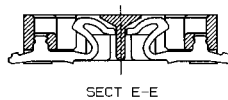
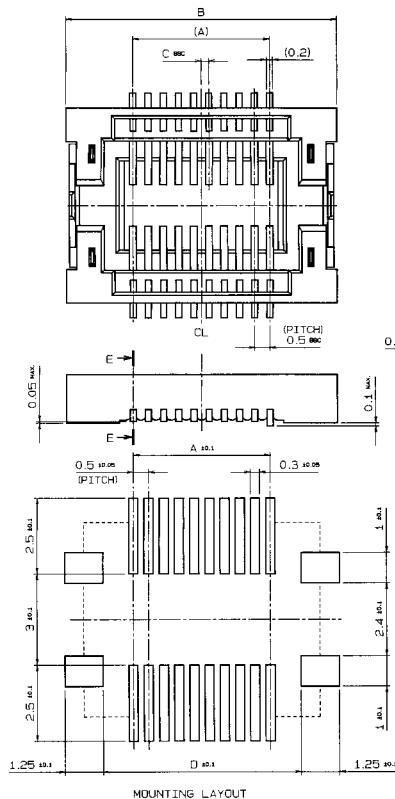

ORDERING CODE

24 5087 0XX X 01 8XX

FINISH
 861 = Ni Under Coated
 1.25µm min.
 Gold-Mating Area
 Au 0.38µm min.
 829 = Ni Under Coated
 1.25µm min.
 Gold-Mating Area
 Au 0.1µm min.

VARIATION
 H = 2.0 ~ 2.5mm

TYPE 0 = without Boss with Retention Clip
 2 = without Boss, Retention Clip
 9 = without Boss, Retention Clip, with Adhesive Tape

NUMBER OF POSITIONS
 (10, 20, 30, 40, 50, 60)

SERIES
 TAPE AND REEL
 24 = Receptacle

Additional information on this product is available from AVX's catalog or AVX's FAX Service.
 Call 1-800-879-1613 and request document #271. Visit our website <http://www.avxcorp.com>

ELCO

4.5 MMS Connector data sheet

The 3 next pages are the RADIALL data sheets for the MMS connector (also available from <http://www.radiall.com/>).

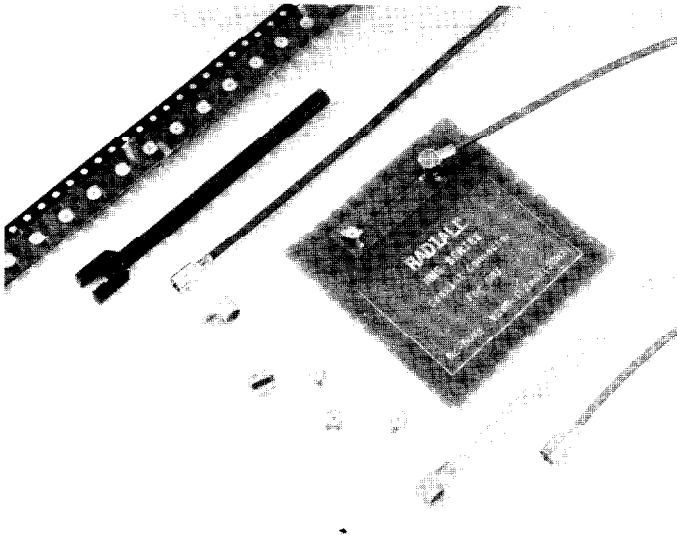

50 Ω	DC - 6 GHz
75 Ω	DC - 1 GHz

GENERAL

- Low profile coaxial connectors
- Surface-mount receptacle (SMT)
- Fully compatible with automated pick and place machines
- Snap-on mating
- High RF performance :
 - VSWR : 1.05 at 1 GHz / 1.15 at 2.5 GHz
 - RF leakage : -40 dB at 2 GHz
- Competitive pricing

APPLICATIONS

- Base stations and hand-sets for :
 - cellular telephones
 - cordless telephones
- Satellite reception terminals (GPS, ...)
- Instrumentation
- Wireless datacom networks
- Automated payment systems
- Videocommunications
- Other general electronics

PROFILE

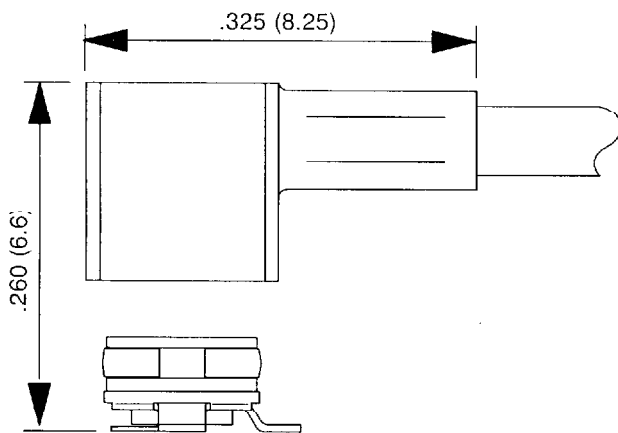

Unmated

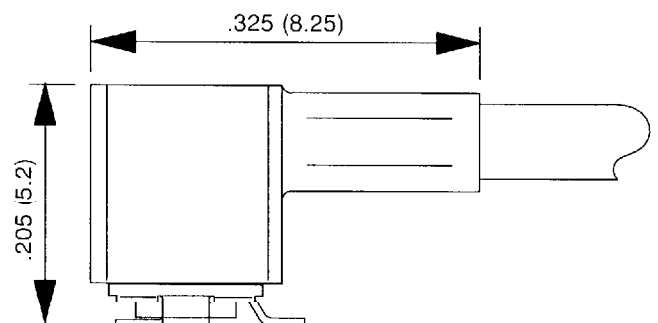

Mated

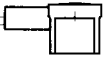

	TEST STANDARD	RESULTS
--	---------------	---------

ELECTRICAL CHARACTERISTICS

Impedance	Frequency range	50 Ω	75 Ω
		DC-6 GHz	DC-1 GHz
V.S.W.R. (mated pair)	IEC 1169-1	1.05 at 1 GHz 1.15 at 2.5 GHz 1.35 at 6 GHz	
Insertion loss	IEC 1169-1	0.2 dB at 2 GHz	
RF leakage (mated pair)	MIL STD 1344 method 3008	-50 dB at 500 MHz -45 dB at 1 GHz -40 dB at 2 GHz	
Outer contact resistance	NF-C 93050 (I = 40 mA peak)	5m Ω max	
Center contact resistance	NF-C 93050 (I = 40 mA peak)	15m Ω max	
Insulation resistance	IEC 1169-1	500 MΩ min (under 250 V RMS)	
Working voltage		50 V RMS	
Testing voltage (V RMS)	IEC 1169-1	Ø 1 mm : 250 ; Ø 2 mm : 500	
Maximum admissible power		40 W at 1 GHz / 20°C / V.S.W.R. = 1	

MECHANICAL CHARACTERISTICS

Durability	IEC 1169-1	50 matings
Force to engage	IEC 1169-1	7 N avg
Force to disengage	IEC 1169-1	5.5 N avg
Shocks (drop test)	IEC 68-2-27	50 g/11 ms ; 3 shocks/axis/way
Random vibrations	Général Motors spec.	Sine waves 5 to 1000 Hz 3 to 30g - 1 H/axis
Bumps (mechanical shocks)	IEC 68-2-29	25 g/6 ms 1000 bumps/axis/way
Cable retention force	IEC 1169-1	Ø 1 mm : 20 N ; Ø 2 mm : 35 N
Solderability	IEC 68-2-54	Passed

ENVIRONMENTAL CHARACTERISTICS

Temperature range		-40°C / +90°C
Climatic cycles	GAM I 13	48 H at 70°C - 24 H at 40°C/93% -36 H at -25°C

MATERIALS

Bodies plugs / in series adapters	Die cast zinc / brass
Bodies receptacles	Phosphor bronze
Center contact male	Brass
Center contact female	Beryllium copper
Insulator	PTFE

PLATING

Bodies plugs, in series adapters	Nickel
Bodies receptacles	Gold
Center contact male	Nickel
Center contact female	Gold

POWER RATING

All dimensions are given in mm.

Example : P = 23 W at F= 1.8 GHz, T = 40°C, V.S.W.R. = 1.1

For any further information about the power handled, please see our power application guide (**D1 033 DE**).

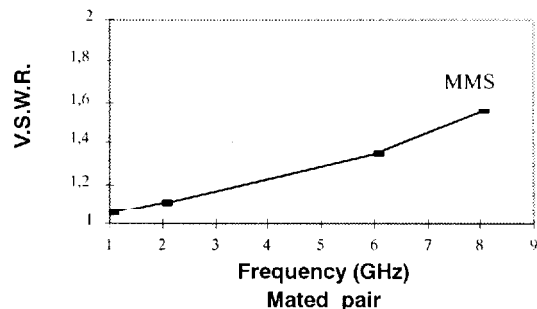
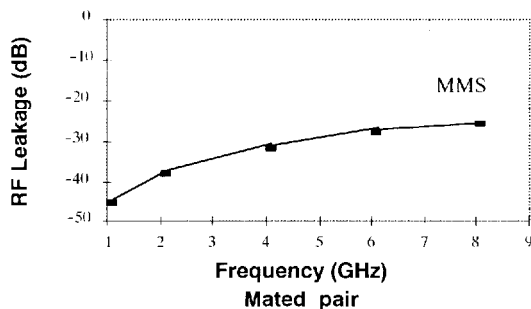

MMS PIGTAILS

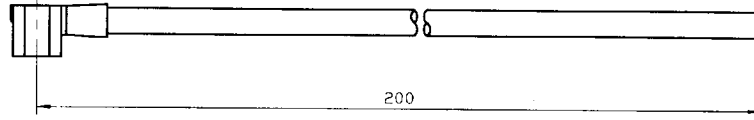
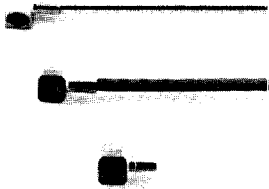

cable group	part number	composition
1 /50/ S	R285 001 001	R209 351 020 + C291 050 066
2 /50/ S	R285 001 021	R209 353 000 + C291 145 060
2 /50/ D	R285 001 031	R209 355 000+ C291 146 087
2 /75/ S	R285 001 041	R209 353 000 + C291 305 000

MMS CABLE ASSEMBLIES

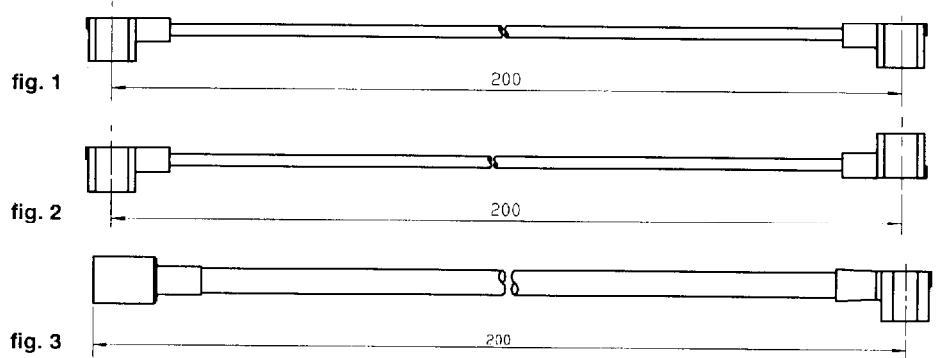

cable group	part number	fig.	composition
1 /50/ S	R285 004 001	1	R209 351 020 + C291 050 066 + R209 351 020
1 /50/ S	R285 005 001	2	R209 351 020 + C291 050 066 + R209 351 020
2 /50/ S	R285 004 221	1	R209 353 000 + C291 145 060 + R209 353 000
2 /50/ S	R285 005 221	2	R209 353 000 + C291 145 060 + R209 353 000
2 /50/ S	R285 003 221	3	R209 080 000 + C291 145 060 + R209 353 000

BETWEEN SERIES CABLE ASSEMBLIES

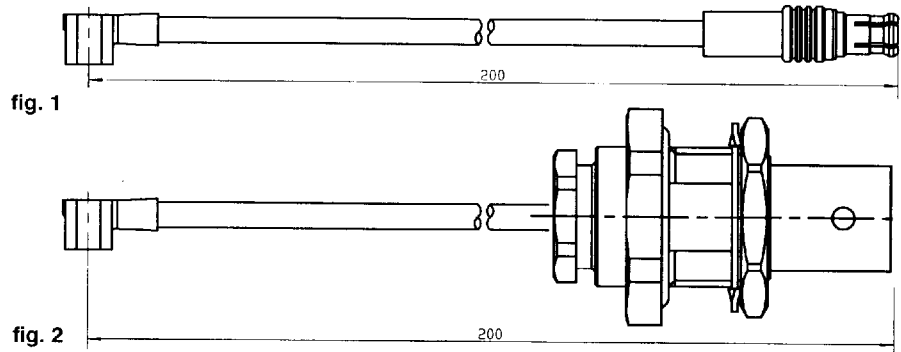
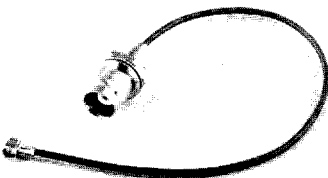

cable group	part number	fig.	composition	series
2 /50/ S	R285 017 221	1	R209 353 000 + C291 145 060 + R113 081 020	MMS/MCX
2 /50/ S	R285 031 221	2	R209 353 000 + C291 145 060 + R141 323 000	MMS/BNC