



GainSpan GS1011M Low Power Wi-Fi[®] Module Family



PRODUCT OVERVIEW

The GS1011M family of fully certified modules offers a quick, easy and cost effective way for device and appliances manufacturers to add Wi-Fi capabilities to their products. The module provides multiple serial UART or SPI interfaces, enabling connection to any embedded design utilizing a 8/16/32-bit microcontroller via simple commands. The GS1011Mx is an ideal solution for organizations with limited or no Wi-Fi or RF expertise, as it not only dramatically reduces RF design time but also removes the burden of testing and certification, allowing customers to focus on their core application, product or expertise. The module supports data rates up to 11 Mbps, is compliant with 802.11b and meets regulatory and Wi-Fi Alliance requirements.

Multiple software configurations are available for the stack running on the module. For applications utilizing a small 8 bit microcontroller host, the module supports a serial to Wi-Fi function and runs the full Wi-Fi and TCP/IP networking stacks, completely offloading the host. For applications utilizing more powerful microcontrollers, the networking stack and services can reside on the host while the module provides the IP to Wi-Fi functionality. In addition, it supports WEP/WPA/WPA2 security, Adhoc as well as Wi-Fi Protected Setup (WPS) for ease of provisioning.

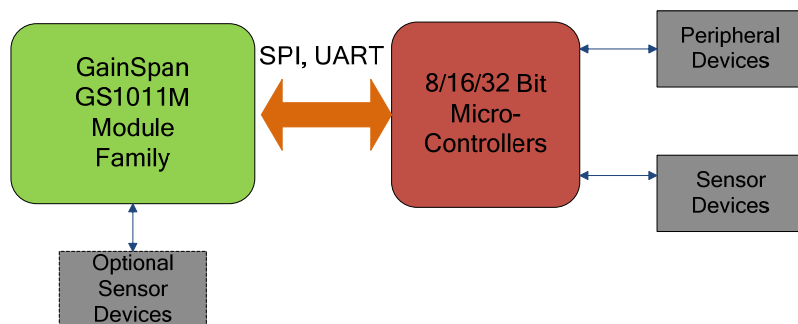

GS1011M based Embedded Design

The module family consists of four different SKU's for antenna configuration and output power. The module SKU's are single sided, pin compatible with castellation on the edges for I/O connection so module can be soldered down on customer application base-board.

SKUs	Power Amplifier	Antenna Option
GS1011MIP	Internal PA	PCB Trace Antenna
GS1011MIE	Internal PA	External Antenna (u.FL)
GS1011MEP	External PA	PCB Trace Antenna
GS1011MEE	External PA	External Antenna (u.FL)

BENEFITS:

- Brings Wi-Fi and web connectivity to any device with a microcontroller and serial HOST interface (UART or SPI)
- Reduces development time, testing and certification burden, accelerating time to market
- Fully contained solution minimizes host processor loading when needed
- Easy device provisioning through ad-hoc or Wi-Fi Protected Set-up (WPS)
- Ultra low power consumption through dynamic power management

FEATURES:

- Operates with standard 802.11 b/g/n access points at speed up to 11 Mbps (802.11b)
 - Infrastructure or Adhoc mode
- Multiple UART and SPI interfaces
 - Supports SPI Master and Slave Modes
 - Up to 11 Mbps in SPI Master Mode
 - Up to 3 Mbps in SPI Slave Mode
 - Up to 921.6 kbps on UART
- Full Wi-Fi stack including WPS and optional networking stack and services
- 802.11i Security
 - WEP, WPA, WPA2-PSK, Enterprise

MODULE HIGHLIGHTS

- Single power source of 3.3V
- Certified Modules (FCC/IC, Wi-Fi)
- Rich I/O interfaces : SPI, UART, GPIO, I2C, ADC, JTAG



GS1011M MODULE SPECIFICATIONS

Radio Protocol	IEEE 802.11b/g/n Compatible
RF Output Power (Typical)	9 dBm (Internal PA) 18 dBm (External PA)
RF Operating Frequency	2.4 - 2.497 GHz
Supported Data Rates	11, 5.5, 2, 1 Mbps (802.11b)
Antenna Options	PCB Trace and U.FL connector for external antenna
Operating Temperature	Industrial (-40° to +85°C)
Security Protocols	WEP, WPA/WPA2 – PSK, Enterprise, EAP-FAST, EAP-TLS, EAP-TTLS, PEAP
Networking Protocols	UDP, TCP/IP (IPv4), DHCP, ARP, DNS, HTTP/HTTPS Client and Server
Certifications and Compliance	Wi-Fi, FCC, IC, Japan, ETSI, RoHS
I/O Interface	UART (2), SPI (2), I2C, ADC (2), WAKE, ALARM (2), GPIOs, PWM, JTAG
Dimensions	Internal PA = 1.28 in X 0.9 in External PA = 1.45 in X 0.9 in
Power Source	3.3V
Power Consumption (Typical)	Standby = <5uA Receive = TBD Transmit = TBD (Internal PA) Transmit =TBD (External PA)

GS1011M BLOCK DIAGRAM

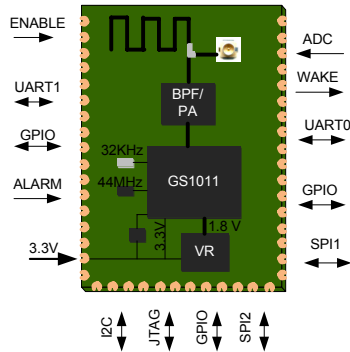

TARGET APPLICATIONS

GainSpan's GS1011 module is easily designed into embedded systems, allowing customers to develop a broad array of devices and appliances that will connect to the Internet. In applications such as healthcare and fitness, smart energy, industrial controls, commercial/building automation, and consumer electronics.

