

SC Analyser 2005

Semiconductor Device Tester

Michel Waleczek

Almost every electronic circuit contains bipolar transistors, FETs or diodes. Most electronics hobbyists have a supply of such components removed from old circuit boards. A tester that can be used to sort out the leads and measure the characteristics is thus a handy tool.



If the markings on the device can still be read, it's usually possible to look up its technical characteristics in a data book. But if the markings are vague or completely missing, you can only guess. Using this particularly handy tester, you can quickly identify the most commonly used types of semiconductor devices (bipolar transistors, JFETs, MOSFETs and diodes), including SMD components. Besides identifying the leads, the tester calculates various parameters, such as H_{FE} for bipolar transistors, V_{TH} , I_{DSS} and $R_{DS(on)}$ for JFETs, the threshold voltage for MOSFETs, and the forward current/voltage and leakage current for diodes. All of this information is clearly displayed on an LCD (compatible) screen.

Operating principle

Each of the three leads of the unknown device is connected to ground or +5 V via resistors with known values. The following resistance values can be used: 100 Ω , 1 k Ω , 5.6 k Ω , and 100 k Ω . For each configuration, three voltages are measured using a PIC16F876 microcontroller.

The microcontroller always starts with a quick, rough measurement to determine whether the device is a bipolar transistor. This is done by connecting two of the three transistor leads to ground while the third lead is connected to +5 V via a 5.6-k Ω resistor. The microcontroller measures the voltage across the resistor and stores the measured value. Two more measurements of this sort are made with different lead sequences, with each measurement being made at the junction of the 5.6-k Ω resistor and the transistor. This yields three values that have a specific relationship to the transistor type.

Table 1 shows the values that should theoretically be measured for NPN and PNP transistors. Here the minus sign corresponds to a connection to ground via a 100- Ω resistor, and the plus sign stands for a connection to +5 V via a 5.6-k Ω resistor. An NPN transistor gives two values of approximately 5 V and one of approximately 0.7 V, while a PNP transistor gives a single value of 5 V and two values of 0.7 V.

The first test is also sufficient to identify the base lead of the transistor, since it is the lead whose value differs from the values for the other two leads. Once

Table 1. Initial measurements				
Type	E	B	C	measured value
NPN	-	-	+	5 V
	+	-	-	5 V
	-	+	-	0.7 V
PNP	-	-	+	0.7 V
	+	-	-	0.7 V
	-	+	-	5 V

the transistor has been identified in this manner, it is tested for current gain. As the positions of the emitter and collector are not known, the current gain is measured for each of the two possible combinations. The ultimate value is taken to be the greater of the two measured values.

If the measured voltages do not match any of the combinations in Table 1, the device is subjected to special tests for other types of components (MOSFET, diode and JFET). To test whether the device is a MOSFET, the current gain is measured in a similar manner for all six of the possible lead arrangements. However, some bipolar transistors also yield results that differ from those shown in Table 1. This primarily occurs with transistors having a protection diode between the collector and the emitter. For such transistors, the current gain is also measured for all six of the possible arrangements.

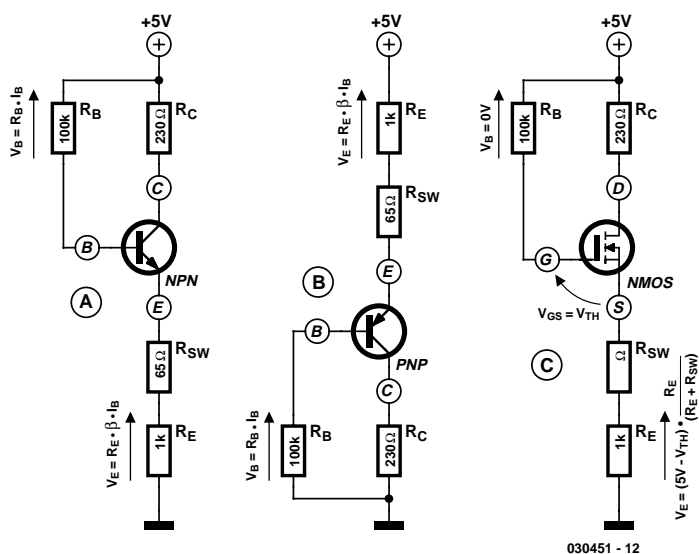

Figure 1. Configurations for measuring the value of β for a transistor and the threshold voltage of a MOSFET.

Limitations

To avoid possible misunderstandings, we must say up front that the SC Analyser 2005 cannot be used to measure thyristors or Darlington transistors.

Measuring current gain for bipolar transistors

The measurements described above have identified the base lead of the transistor, and now the other two leads are identified by connecting the transistor in a common-collector configuration if it is a bipolar transistor, or in a source-follower configuration if it is a MOSFET (see Figure 1).

The gain of the transistor is determined by measuring V_B and V_E . The formulas for this parameter are:

$$V_E = R_E \times (\beta + 1) \times (V_B \div R_B)$$

$$\beta = [(V_E \times R_B) \div (V_B \times R_E)] - 1$$

The circuit can measure gain values over a range of 5 to 999. An N-channel MOSFET (Figure 1c) can be distinguished from a bipolar transistor by the fact that its gate current is practically zero. In this case, the threshold voltage corresponds to the voltage $V_{CC} - V_E$ (for an N-channel type). To be properly identified by the tester, the MOSFET must have a threshold voltage less than 4.5 V, and it must be an enhancement type (which is almost always the case). The other type of MOSFET, which is

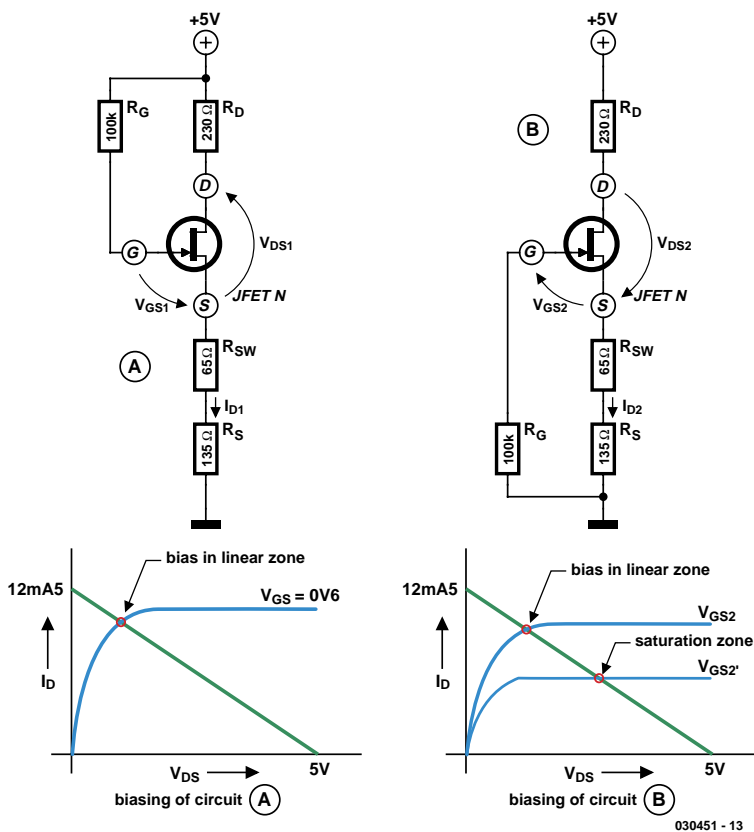

Figure 2. Configuration for measuring JFET parameters.

called a depletion type, is scarcely used any more.

Measuring FET parameters

Field-effect transistors (FETs) can be characterised by a certain number of parameters, but here we are only inter-

ested in three of them: V_{TH} (gate-source threshold voltage), I_{DSS} (drain saturation current), and R_{DSON} (resistance in the full 'on' state). Determining these parameters is more complicated than simply measuring the current gain of a bipolar transistor. The topology of the circuit is hardly suitable for making direct measure-

ments, so an indirect method based on a mathematical model of the FET (the Schichman-Hodges model) is used to determine the values of the above-mentioned three parameters by calculation. Of the three principal parameters of this static model, which is primarily used in Spice simulation, it turns out that only two are actually necessary here, since the third parameter (λ) has hardly any effect on the ultimate calculation (see inset).

In order to determine the values of these two parameters, it's necessary to examine two specific operating points in order to obtain a set of two equations. In the first case, the FET is biased in its linear operating region (Figure 2a) by using resistor R_G to force V_{GS1} to approximately 0.6 V. Some FETs with low saturation currents can be biased into their saturation region in this configuration, and in such cases a variation on the circuit shown in Figure 2 is used, but this is not described any further here. The first configuration yields the first set of values for V_{DS1} , V_{GS1} and I_{D1} . The second operating point is obtained by configuring the transistor to operate as a current source (Figure 2b), which yields a second set of values (V_{DS2} , V_{GS2} and I_{D2}).

Now things become a bit more complicated, because the second operating point can lie in the linear region or the saturation region. The operating region cannot be determined until the threshold voltage V_{TH} is known. There's thus no other choice than to calculate the value of V_{TH} for each type of operating region and then choose the proper value from the two results by checking the corresponding operating regions. The resistances R_{SW} of the analogue switches are shown in the schematic diagram in Figure 3. They have a value of approximately 65 Ω . The exact values are determined using an automatic calibration procedure. The drain resistance, which is approximately 230 Ω , consists of a 100- Ω resistor, the resistance of the analogue switch (65 Ω), and the output resistance of the micro-processor (65 Ω).

Another factor that must be borne in mind is that most FETs are symmetric, which means that the drain and source are interchangeable. It is thus impossible to tell these two leads apart, so the tester can only actually identify the gate lead. The drain and source leads are indicated according to the configuration used for calculating the transistor parameters. Interchanging the

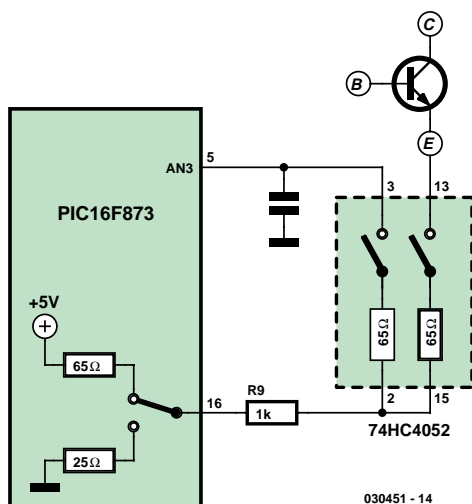

Figure 3. The Kelvin circuit avoids errors due to the internal resistance of the 74HC4052.

source and drain leads will not change the information shown on the display of the SC Analyser 2005, but the results of the calculation always correspond to indicated lead arrangement.

Schematic diagram

The complete schematic diagram of the circuit is shown in **Figure 4**. The circuit draws approximately 6 mA (except for the backlight, which needs around 20 mA), and it is powered by a 9-V battery. A 78L05 voltage regulator

combined with three decoupling capacitors reduces the voltage to exactly 5 V in order to power the PIC16F876, the LCD (with backlight), and the three 74HC4502 multiplexers. The display module communicates with the microcontroller in 4-bit mode via five Port C leads and lead RA5 of Port A. The PIC16F876 is clocked at approximately 1 MHz by the R10/C4 network. The PIC16F876 differs from the 'classic' 16F84 by having an on-board A/D converter, which is used in this circuit. The Reset pin can be tied

directly to +5 V, since the microcontroller has an automatic reset function. The three control signals for the transistor being tested come from RC4, RC5 and RC6 in Port C. These signals, which have levels of 0 V or 5 V, are routed to the three test terminals via three analogue multiplexers in order to insert resistors with specific values between the microcontroller outputs and each of the test terminals. The resistance values are determined by selection signal pairs RB4 and RB5 for the right-hand signal (J1), RA2 and

Measuring FETs with the Schichman-Hodges model

The static characteristics of a JFET can be represented by a set of formulas that express the drain current as a function of the voltages V_{GS} and V_{DS} of the FET. There are two different formulas, since the model distinguishes between the linear region $0 \leq V_{DS} \leq (V_{GS} - V_{TH})$ and the saturated region $V_{DS} \geq (V_{GS} - V_{TH})$, where V_{TH} is the threshold voltage of the FET.

The full model employs three parameters: β , λ , and V_{TH} . Parameter β is related to the saturation current and the threshold voltage, while parameter λ represents the channel-length modulation factor and is neglected in our calculations ($\lambda = 0$). The mathematical model that we use thus appears as follows:

For the linear region, defined as $0 \leq V_{DS} \leq (V_{GS} - V_{TH})$, the following formula applies:

$$I_D = \beta \cdot V_{DS} \cdot [2 \cdot (V_{GS} - V_{TH}) - V_{DS}] \cdot (1 + \lambda \cdot V_{DS})$$

For the saturation region, defined as $V_{DS} \geq (V_{GS} - V_{TH})$, the following formula applies:

$$I_D = \beta \cdot (V_{GS} - V_{TH})^2 \cdot (1 + \lambda \cdot V_{DS})$$

As we have seen, in the first configuration the FET is in the linear region with an adequately large I_{DSS} , so the first formula becomes:

$$I_{D1} = \beta \cdot V_{DS1} \cdot [2 \cdot (V_{GS1} - V_{TH}) - V_{DS1}] \quad [1]$$

In the second configuration, the FET can be in the linear mode with:

$$I_{D2} = \beta \cdot V_{DS2} \cdot [2 \cdot (V_{GS2} - V_{TH}) - V_{DS2}] \quad [2]$$

or it can be in the saturated mode with:

$$I_{D2} = \beta \cdot (V_{GS2} - V_{TH})^2 \quad [3]$$

In this manner, we obtain a set of two equations in which V_{TH} and β are the unknowns. Depending on the operating region of the FET, we must use either formula [2] or formula [3].

If we assume that the FET is operating in the linear region, formulas [1] and [2] yield:

$$V_{THLIN} = C - (V_{GS2} - V_{DS2})^2 / (V_{DS2} - V_K) \quad [4]$$

where

$$V_K = (I_{D2} \div I_{D1}) \cdot V_{DS1}$$

and

$$C = V_{GS2}^2 + V_K \cdot (V_{DS1} - 2 \cdot V_{GS1}) \quad [5]$$

Consequently, we can calculate the constant B as follows:

$$B = 2 \cdot (V_K - V_{GS2}) \quad [6]$$

If the operating point of the FET is in the saturated region, formulas (1) and [3] yield a second-order equation:

$$V_{TH}^2 + B \cdot V_{TH} + C = 0$$

We now have two solutions for V_{TH} :

$$V_{TH1} = -B + \sqrt{B^2 - 4 \cdot (C \div 2)} \quad [7]$$

and

$$V_{TH2} = V_{THSAT} = -B - \sqrt{B^2 - 4 \cdot (C \div 2)} \quad [8]$$

Only one of these solutions is physically possible, and this is determined by evaluating the two expressions. All that's left to do now is to determine V_1 and V_2 in order to figure out the actual operating region of the FET in the second configuration:

$$V_1 = V_{GS2} - V_{THLIN} - V_{DS2}$$

$$V_2 = V_{GS2} - V_{THSAT} - V_{DS2}$$

If $V_1 > 0$ and $V_2 < 0$, the FET is operating in the linear region and $V_{TH} = V_{THLIN}$.

If $V_1 < 0$ and $V_2 > 0$, the FET is operating in the saturated region and $V_{TH} = V_{THSAT}$.

If the FET is operating in the saturated region, the I_{DSS} parameter corresponds to the drain current for $V_{GS} = 0$. For V_{DS} , we take the value corresponding to the boundary of the saturation region, which is $V_{DS} = V_{GS} - V_{TH} = -V_{TH}$.

Substituting for V_{DS} in equation [2] or [3] yields:

$$I_{DSS} = \beta \cdot V_{TH}^2$$

The value of can be easily calculated by rearranging formula [1] as follows:

$$\beta = I_{D1} \div \{ V_{DS1} \cdot [2 \cdot (V_{GS1} - V_{TH}) - V_{DS1}] \}$$

The resistance R_{DSON} corresponds to the slope at the origin of the characteristic curve:

$$V_{DS} = f(I_D) \text{ if } V_{GS} = 0$$

Finally, formula [1] yields the following results when V_{DS} approaches 0 V:

$$I_D = -2 \cdot \beta \cdot V_{DS} \cdot V_{TH}$$

$$R_{DSON} = dV_{DS} / dI_D = -[1 \div (2 \cdot \beta \cdot V_{TH})]$$

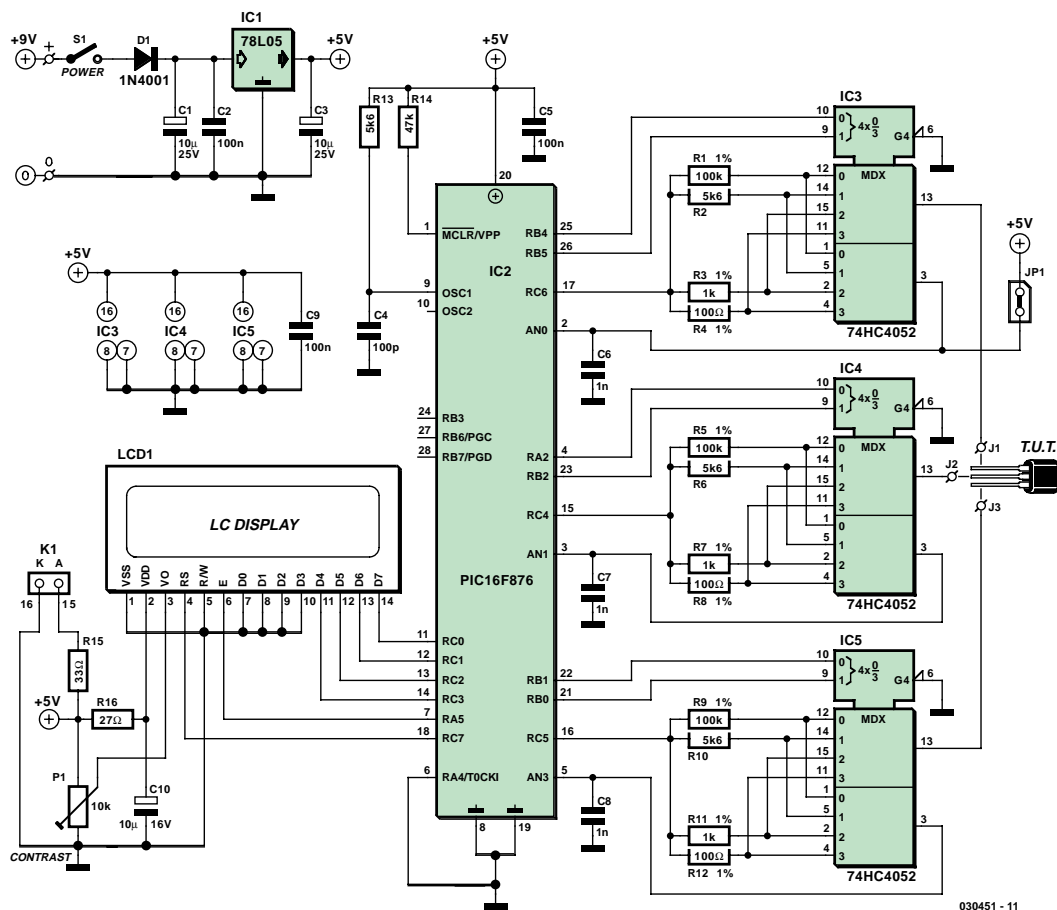

Figure 4. Complete schematic diagram of the SC Analyser 2005.

RB2 for the centre signal (J2), and RB1 and RB2 for the left-hand signal (J3). The voltages present on the test terminals are measured by the PIC15F876 via analogue inputs AN0, AN1 and AN3.

In order to compensate for the effects of the internal resistances of the analogue switches when making current measurements, these measurements are made using a second switch in each 74HC4052 instead of directly at the leads of the unknown transistor. The operation of this arrangement is shown schematically in **Figure 3** with resistor R9 connected in the circuit. The internal resistance of the microcontroller output, which is around 30 Ω, must also be taken into account. Finally, three 1-nF capacitors provide a certain amount of filtering for the measured signals.

Software

The software is written entirely in assembly language and fills a large chunk of the memory space of the PIC16F876. Approximately half of the

occupied space is used for calculating parameter values for FETs. If you would like to program your own microcontroller, you can download the necessary hex code from the *Elektor Electronics* website (www.elektor-electronics.co.uk). The file is found with the pdf download for this article (April 2005). For those of you without Internet access it is also available on floppy disk from Reader Services, the order code is **0304051-11**. Naturally, you can also order a fully programmed microcontroller from Reader Services (order no. **030451-41**).

Construction

The PCB layout and component layout are shown in **Figure 5**. Ensure that the IC sockets, electrolytic capacitors, 5-V regulator and the four ICs are fitted the right way around.

The 1% resistors can be replaced by 5% metal-film resistors carefully selected using an accurate and reliable multimeter. The analogue switches must be 74HC types, since the internal resistance of the normal 4000 series is too

large for this application.

The display module can be fitted on the copper side of the circuit board. To make it easy to connect the display, there is a single-row 16-way pinheader (male) on the circuit board, which mates with a corresponding 16-way female connector on the display circuit board. Here we chose to use a modern type of display called 'PLED' (see the 'OLED and PLED' inset), but you can also use any desired LCD module based on (or compatible with) the Hitachi HD44780, although the pin arrangement may differ from the arrangement for the display used here. Note that the pin arrangement of the display used here is rather unusual, with pins 15 and 16 for the backlight being located next to pin 1.

Beside the test leads with alligator clips, there is also a special test circuit board that is connected to the main circuit board and can be used to simplify testing SMD devices (diodes and transistors). Use three short, flexible leads to connect the SMD holder to the main circuit board, and ensure that the proper lead sequence is maintained (as

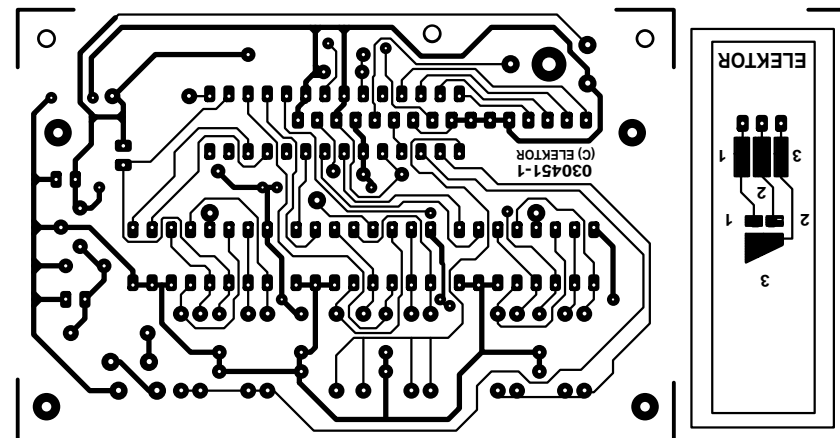
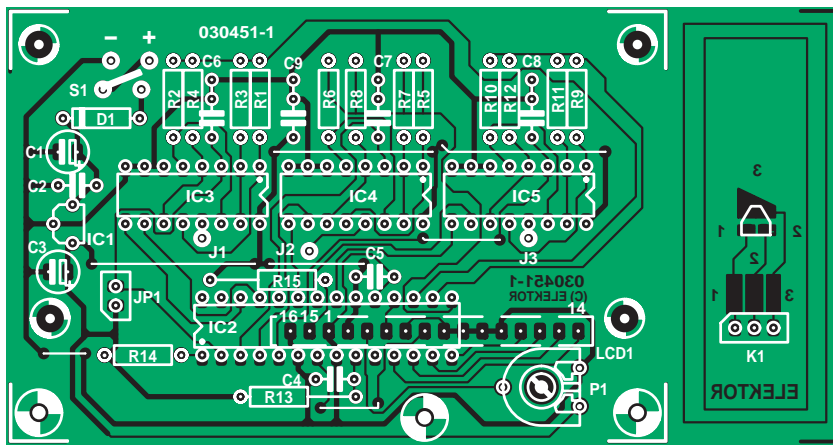

Figure 5. Track and component layouts for the associated printed circuit board. SMD components can be conveniently tested using the small circuit board.

seen from above: contact 1 to J1, contact 2 (middle) to J2, and contact 3 to J3). Although this hardly matters for the measurements, it is important for

identifying the leads. **The middle contact must always be connected to J2.** Naturally, you can also use flexible leads with miniclips. The circuit board

is designed to fit in a standard enclosure with a 9-V battery compartment.

Calibration

After the tester is switched on, a welcome message appears and displays the software version (*SC-Analyser 2005 Elektor Rev. 1.0e*). If you don't see this message, try adjusting contrast control P1 to improve the situation.

The first thing you should do is to calibrate the internal resistances of the analogue switches. If these values are known as exactly as possible, the measurements of the various transistor parameters will be more accurate. If this calibration is not performed, a default value of $65\ \Omega$ is used for each switch. Each time the tester is switched on, the software checks to see whether the calibration has taken place, and if it hasn't, the message 'Cal error' is displayed for approximately one second.

The calibration procedure is easy and runs automatically. To perform the procedure, fit a jumper in position JP1 while the tester is switched off and short all three test leads together, and then switch the tester on. The message 'Cal Remove jumper' will be displayed on the tester. Now you should remove the jumper, and the calibration procedure will start. Three resistances are measured one after the other, and their values are displayed successively. Next, the message 'Short $R_{SH}\ XX\ \Omega$ ' will appear. After this you can disconnect the three test leads from each

COMPONENTS LIST

Resistors:

R1, R5, R9 = $100\text{k}\Omega$, 1%
 R2, R6, R10, R13 = $5\text{k}\Omega$
 R3, R7, R11 = $1\text{k}\Omega$, 1%
 R4, R8, R12 = $100\ \Omega$, 1%
 R14 = $47\text{k}\Omega$
 R15 = $33\ \Omega$
 R16 = $27\ \Omega$
 P1 = $10\text{k}\Omega$ preset

Capacitors:

C1, C3 = $10\ \mu\text{F}$ 25V radial
 C2, C5, C9 = 100nF
 C4 = 100pF
 C6, C7, C8 = 1nF MKT
 C10 = $10\ \mu\text{F}$ 16V radial

Semiconductors:

D1 = 1N4001
 IC1 = 78L05
 IC2 = PIC16F876-20/SP (programmed,

order code **040409-41**)
 IC3, IC4, IC5 = 74HC4052 (HC only!)

Miscellaneous:

S1 = on/off slide switch
 LCD1 = standard LCD with 2×16 characters, e.g., ASI-G-162FS-GF-EWS/W (with backlight) or LCD 162C BL (P-LED with active backlight)
 16-way SIL pinheader with mating connector, or flatcable for connection to display
 JP1 = 2-way pinheader with jumper
 3 mini croc clips*
 3 DIL16 IC sockets
 1 DIL28 IC socket
 Enclosure, e.g., Hammond 1591BTBU
 9-V battery with clip-on leads
 5 wire links
 PCB, order code **030451-1** (see Readers services or www.elektor-electronics.co.uk)
 Disk, PIC hex code, order code **030451-11** or free download from www.elektor-electronics.co.uk

* see text

μC configuration

The microcontroller must be configured with the following options:

- oscillator in RC mode
- watchdog timer (WDT) disabled
- 'timer reset on power on' enabled
- brownout reset disabled
- EEPROM protection disabled
- writing to Flash memory disabled
- debug mode disabled
- code protection disabled

other, and the tester will automatically change to the test mode and display the message 'No component *-*-*'. Calibration can be performed whenever desired by repeating the above procedure (switch off the power, fit the jumper, and switch the power on again).

If you experience any problems, check that the five wire bridges are in fact properly fitted and soldered in place. Also check to make sure that the supply voltage is present at the IC sockets.

Operation

After the welcome message showing the software version (*SC-Analyser 2005 Elektor Rev. 1.0e*), the display should show the following information (**Photo 1**).

The first line shows the transistor type and the value of one of the characteristic parameters. The second line shows the lead arrangement of the transistor and, if relevant, the value of a second parameter.

Bipolar transistor

The first line of the display shows the polarity of the transistor (PNP or NPN), the type of semiconductor material (silicon or germanium), and the parameter H_{FE} . The second line shows the lead arrangement of the transistor and the collector current. The current has a value of approximately 1.5 to 4 mA, depending on the current gain. The SC Analyser 2005 displays the type of semiconductor material ('Ge' for germanium or 'Si' for silicon) according to the measured value of V_{BE} (**Photo 2**).

If the transistor is partially or completely shorted, the associated leads are marked with an 'X' by the SC Analyser 2005. A short is considered to be present if the resistance measured between two leads is less than 50Ω (**Photo 3**).

FETs

The values of the parameters V_{TH} , I_{DSS} and $R_{DS(ON)}$ are shown approximately every two seconds. The drain and source leads are determined arbitrarily by the SC Analyser 2005, but they do correspond to the configuration actually used to determine the parameters. If you swap the drain and source leads of the transistor under test (TUT), you can obtain the values for the reverse configuration, but since field effect transistors have symmetric structures,

OLED and PLED

Organic LED (OLED) and polymeric LED (PLED) are recent developments in LED technology. The OLED effect was discovered in the early 1980s by Eastman Kodak, but it has only recently been put to practical use in commercial applications such as PDAs and MP3 players. The Kodak LS633 digital camera was one of the first devices to be fitted with an OLED screen. Some of the MP3 players from Packard Bell also have an especially nice OLED display.

OLEDs are based on LCD technology. A sandwich formed of several layers of organic film is located between two charged electrodes: a metal cathode and a transparent anode. There are four organic films in total: a hole injection layer, a hole transport layer, an emission layer and an electron transport layer. As soon as a voltage is applied, the positive and negative charges combine in the emission layer to generate electroluminescent light. In contrast to LCDs, which need an external source of light (backlight), OLEDs actively emit light.

An even more recent development is the PLED, in which an undoped polymer is sandwiched between two electrodes. The polymer lights up when a voltage is applied. This device can produce a full range of colours and is relatively inexpensive compared with other technologies, such as LCD and OLED.

The advantages of PLEDs are that they require only a small amount of power for high brightness, they are relatively light, robust and fast, and they operate over a relatively large temperature range.

Comment from our design staff:

As you have probably realised, we are quite enthusiastic about the visual properties of the PLED display used in this project. However, we are highly disappointed with the inadequate design of this display. It generates huge current spikes with amplitudes up to several hundred milliamperes, which create a lot of noise on the 5-V supply line. In our opinion, this is caused by a poor hardware design for the display (Version A), with inadequate attention being given to the switching times required by the display drivers. Due to this problem, we were forced to include an extra RC network

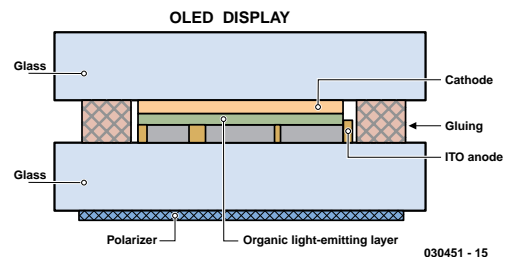

Cross-section of an OLED display.
The structure of a PLED is similar.

in the +5-V supply.

We do not (yet) know whether PLED displays from other manufacturers suffer from the same shortcoming. If you can get your hands on a different brand of PLED display, it would be interesting to just measure what sort of current pulses it draws.



there shouldn't be any large differences in the measured values.

Considering the method used to make the measurements, the accuracy of the values provided by the SC Analyser 2005 is more than adequate. For I_{DSS} it is $\pm 5\%$, and for $R_{DS(on)}$ it is $\pm 5\%$. However, the measured value of the threshold voltage can differ from the true value by 0.5 V for certain transistors, although in general an accuracy of 50 mV is achieved. A particular type of FET from one manufacturer may yield a value that is very close to the true value, while the same type from a different manufacturer yields a value that differs by several hundred millivolts. In practice, the accuracy is related to the accuracy of the Schichman-Hodges model and reveals the limitations of this model (refer to the inset on this subject).

Threshold voltage

The threshold voltage is negative for N-channel FETs and positive for P-channel FETs. The maximum value is limited to ± 20 V by the software. The resolution is 10 mV for values up to ± 9.99 V and 100 mV for larger values (Photo 4).

Saturation current

The saturation current (with the gate shorted to the source) is shown here. The value of the saturation current ranges from 0 to 99.9 mA. The resolution is 10 μ A for currents up to 10 mA and 100 μ A for currents up to 100 mA (Photo 5).

Drain-source resistance

This is the drain-source resistance when the FET is fully 'on' with $V_{GS} = 0$ V. The measurement has a range of 0–999 Ω (Photo 6).

MOSFETs

The displayed voltage corresponds to the threshold voltage of the MOSFET for a drain current of approximately 2 mA. The measurement range is 0–4.5 V, with a resolution of 10 mV. For proper identification of the device as a MOSFET, the gate leakage current must not exceed 0.5 μ A (Photo 7).

Diodes

Diodes can be connected between the left-hand and right-hand terminals of the tester. The SC Analyser 2005 indicates the positions of the anode and cathode. Three screens are displayed in sequence at an interval of approximately 2 seconds. The first screen

shows the voltage and the current through the diode via a resistance of approximately 400 Ω . The maximum current is thus limited to around 12 mA (Photo 8).

The second screen shows the same information, but this time with a resistance of approximately 5.9 k Ω , which causes the maximum current to be limited to approximately 800 μ A (Photo 9).

The third screen shows the current in the reverse direction and the test voltage. The resolution is 100 nA (Photo 10).

SMDs

You've probably been wondering how to use the SMD portion of the tester. The leads of the component to be tested must make contact with the corresponding copper areas on the circuit board. SMD diodes must be connected between area 1 and area 3. A small plastic rod can be used to properly press an SMD device against the circuit board so that its leads make good contact.

Conclusion

The SC Analyser 2005 is a handy, easily constructed instrument with a large number of features, which can be a quite valuable aid to electronics hobbyists and professionals. A brief list of its possible applications includes searching for an equivalent type, testing device operation, sorting devices, measuring unmarked transistors, and simply determining the lead arrangement without thumbing through a data book. Time to warm up your soldering iron!

(030451-1)

Internet links

Author's website:
www.mwinstruments.com

FAQ site:
www.mwinstruments.com/SCA2005/sca2005.html

Author's e-mail address:
m.waleczek@mwinstruments.com

Microchip:
www.microchip.com/download/lit/pline/picmicro/families/16f87x/30292c.pdf

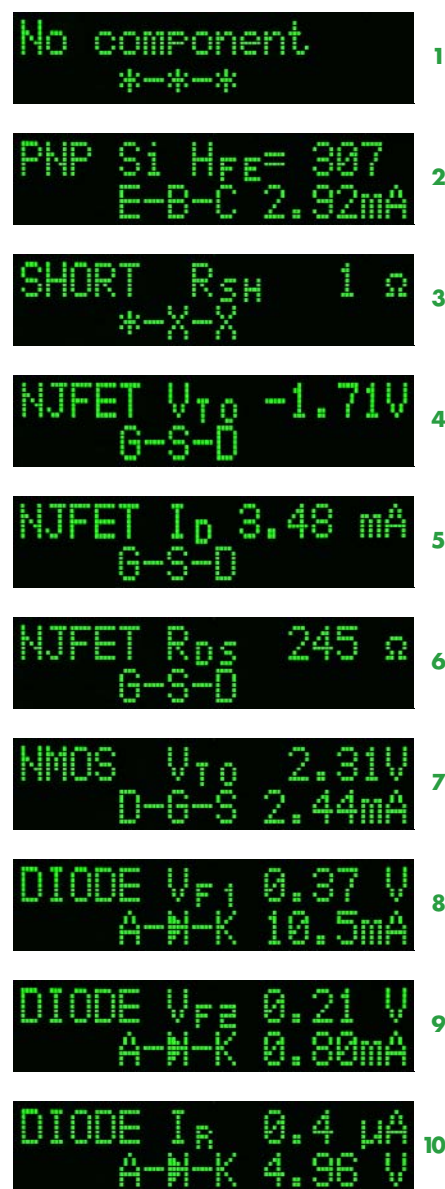

About the author

The author was born in 1965 and studied at the École Nationale Supérieure d'Électronique et de Radioélectricité de Grenoble (ENSERG) in France. He worked as an engineer for seven years in the research department of a large French manufacturer of weighing equipment. Following this he changed to the French branch of Hameg, where he holds the position of Director of Development. Between his travels to the other side of the globe, he manages to find a bit of time to design measurement instruments for electronic hobbyists.

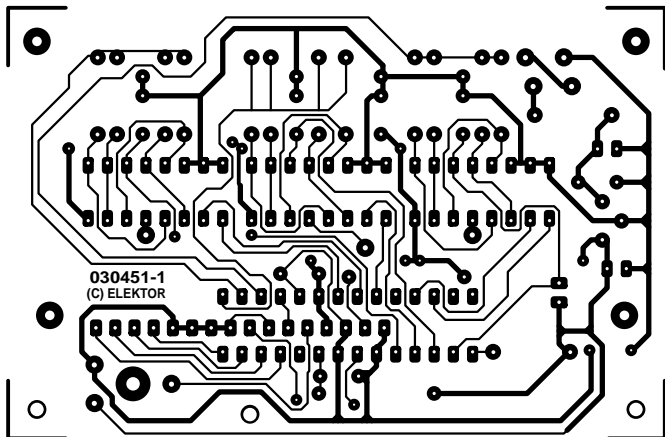
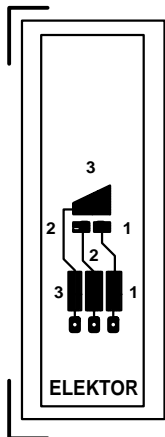

non reflected

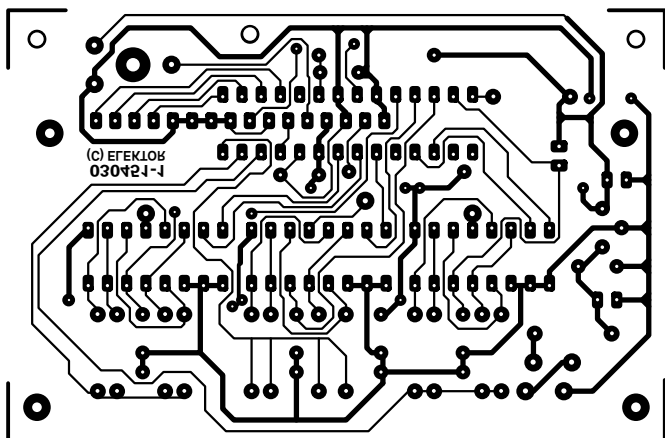
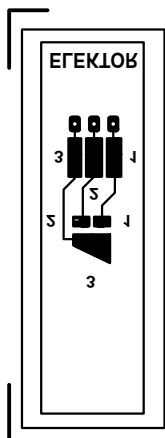

reflected