

TOSHIBA BIPOLAR LINEAR INTEGRATED CIRCUIT SILICON MONOLITHIC

# TA7257P

## BRIDGE DRIVER

The TA7257P is a Full Bridge Driver for brushed DC Motor Rotation control.

Forward Rotation, Reverse Rotation, Stop and Braking operations are available.

It's designed for Loading and Reel Motor driver for VTR and Tape Deck, and any other consumer and industrial applications.

TA7257P have Operation Supply Voltage terminal and Motor Driving Supply Voltage terminal independently therefore Servo control operation is applicable.

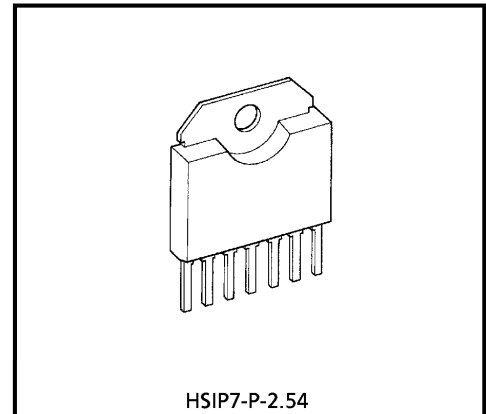

HSIP7-P-2.54

Weight : 1.88 g (Typ.)

### FEATURES

- Output Current Up to 1.5 A (AVE.), and 4.5 A (PEAK).
- 4 Function Modes (CW, CCW, STOP and Brake) are Controlled by 2 Logic Signals Fed Into 2 Input Terminals.
- Build in Over Current Protector and Thermal Shut Down Circuit.
- Operating Voltage Range :  $V_{CC(opr.)} = 6\sim 18V$ ,  $V_S(opr.) = 0\sim 18V$

### BLOCK DIAGRAM

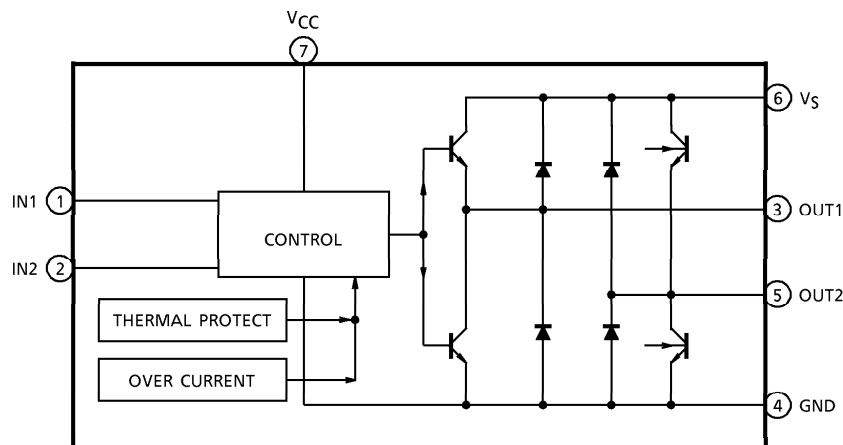

980910EBA1

- TOSHIBA is continually working to improve the quality and the reliability of its products. Nevertheless, semiconductor devices in general can malfunction or fail due to their inherent electrical sensitivity and vulnerability to physical stress. It is the responsibility of the buyer, when utilizing TOSHIBA products, to observe standards of safety, and to avoid situations in which a malfunction or failure of a TOSHIBA product could cause loss of human life, bodily injury or damage to property. In developing your designs, please ensure that TOSHIBA products are used within specified operating ranges as set forth in the most recent products specifications. Also, please keep in mind the precautions and conditions set forth in the TOSHIBA Semiconductor Reliability Handbook.
- The products described in this document are subject to the foreign exchange and foreign trade laws.
- The information contained herein is presented only as a guide for the applications of our products. No responsibility is assumed by TOSHIBA CORPORATION for any infringements of intellectual property or other rights of the third parties which may result from its use. No license is granted by implication or otherwise under any intellectual property or other rights of TOSHIBA CORPORATION or others.
- The information contained herein is subject to change without notice.

## PIN FUNCTION

PIN No.	SYMBOL	FUNCTIONAL DESCRIPTION
1	IN1	Input terminal
2	IN2	Input terminal
3	OUT1	Output terminal
4	GND	GND terminal
5	OUT2	Output terminal
6	V <sub>S</sub>	Supply voltage terminal for Motor drive
7	V <sub>CC</sub>	Supply voltage terminal for Logic

## FUNCTION

IN1	IN2	OUT1	OUT2	MODE
1	1	L	L	Brake
0	1	L	H	CW / CCW
1	0	H	L	CCW / CW
0	0			Stop

## MAXIMUM RATINGS (Ta = 25°C)

CHARACTERISTIC		SYMBOL	RATING	UNIT
Peak Supply Voltage	Peak	V <sub>CC</sub> (MAX.)	25	V
	Operate	V <sub>CC</sub> (opr.)	18	
Output Current	PEAK	I <sub>O</sub> (PEAK)	4.5	A
	AVE.	I <sub>O</sub> (AVE.)	1.5	
Power Dissipation		P <sub>D</sub>	12.5 (Note)	W
Operating Temperature		T <sub>opr</sub>	-30~75	°C
Storage Temperature		T <sub>stg</sub>	-55~150	°C

(Note) T<sub>c</sub> = 75°C

**ELECTRICAL CHARACTERISTICS (Ta = 25°C)**

CHARACTERISTIC	SYMBOL	TEST CIRCUIT	TEST CONDITION	MIN.	TYP.	MAX.	UNIT
Supply Current	I <sub>CC1</sub>	—	V <sub>CC</sub> = 18 V Output OFF stop mode	—	6.5	13	mA
	I <sub>CC2</sub>		V <sub>CC</sub> = 18 V Output OFF CW/CCW mode	—	10	20	
Saturation Voltage	Upper	V <sub>S1U</sub>	V <sub>CC</sub> = 18 V, I <sub>O</sub> = 0.1 A	—	0.7	1.0	V
	Lower	V <sub>S1L</sub>		—	0.6	0.9	
	Upper	V <sub>S2U</sub>	V <sub>CC</sub> = 18 V, I <sub>O</sub> = 1.1 A	—	1.0	1.4	
	Lower	V <sub>S2L</sub>		—	0.9	1.3	
Output Transistor Leakage Current	Upper	I <sub>L</sub> U	V <sub>S</sub> = 18 V	—	—	100	μA
	Lower	I <sub>L</sub> L		—	—	100	
Input Voltage 1, 2	V <sub>IN</sub> (H)	—	T <sub>j</sub> = 25°C, pin ① and pin ②	3.0	—	—	V
	V <sub>IN</sub> (L)			—	—	0.8	
Diode Forward Voltage	V <sub>F</sub> U	—	I <sub>F</sub> = 1.0 A	—	2.0	—	V
	V <sub>F</sub> L			—	1.25	—	
Limiting Current	I <sub>SC</sub>	—	—	—	3.5	—	A
Input Current	I <sub>IN</sub>	—	—	—	1	10	μA

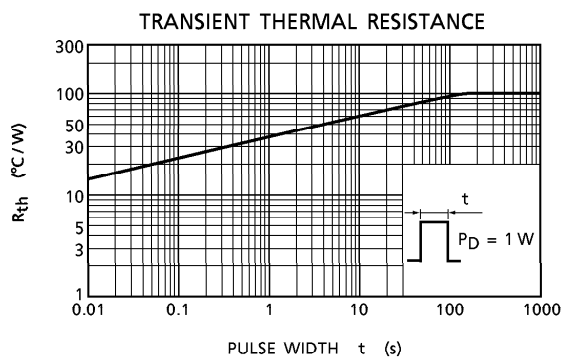
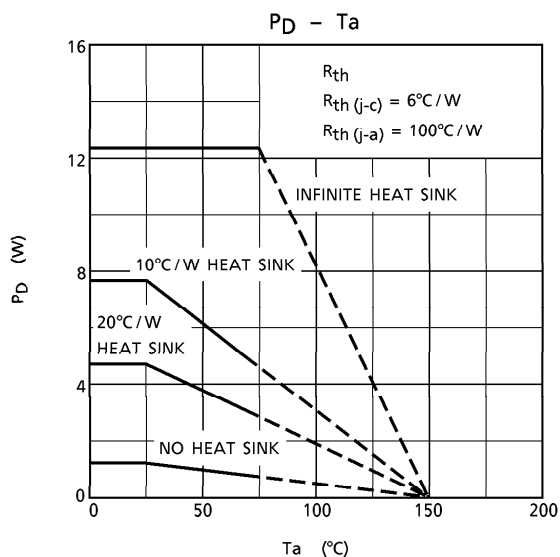

**APPLICATION NOTE**

(1) Input circuit

Input circuit is shown in Fig.1. It's a "Low active" type voltage comparator that's one input connect to Input terminal (pin ①, or ②) and the other to built-in temperature compensated voltage reference ( $V_{TH} = 1.4V$  Typ.)

If a voltage above  $V_{IN(H)}$  fed into the Input Terminal that means "Logic 1" and less than  $V_{IN(L)}$  or connect to GND means "Logic 0".

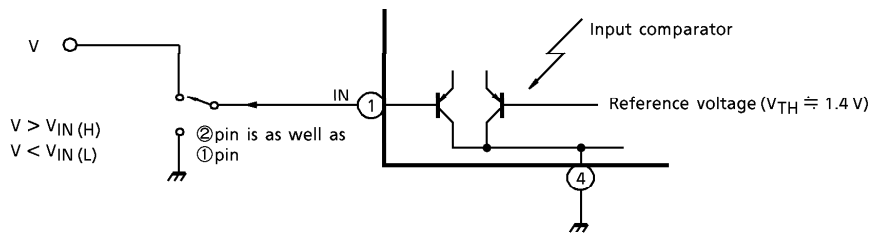

Fig.1

(2) Basic application circuit

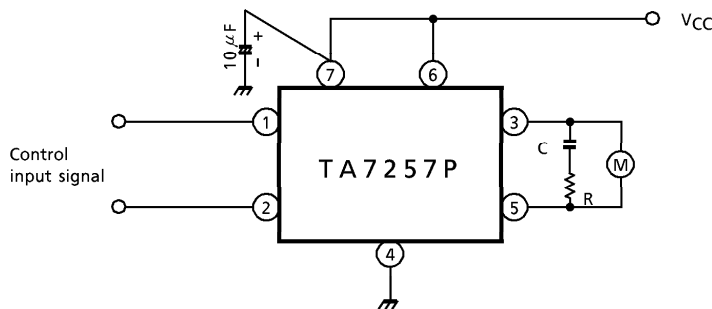

Fig.2

- (Note 1) Fig.2 shows the basic application circuit. Optimum values of the C, R depend on the inherent constant of a motor and parasitic C, R values around the circuit. Normally, recommended to use 0.1  $\mu F$  and 33  $\Omega$ .
- (Note 2) Utmost care is necessary in the design of the output line,  $V_S$ ,  $V_{CC}$  and GND line since IC may be destroyed due to short-circuit between outputs, air contamination fault, or fault by improper grounding.
- (Note 3) Be careful when switching the input because rush current may occur. When switching, stop mode should be entered or current limitation resistor R should be inserted.
- (Note 4) The IC functions cannot be guaranteed when turning power on of off. Before using the IC for application, check that there are no problems.

## (3) Additional diode

- i) If the braking operation is so loose, connect a additional diode between each output to GND, (See Fig.3)
- ii) If the back electromotive pulse generated in output coil is so strong. Internally connected back electromotive suppression diode may be damaged by this pulse. In such a case connect a additional diode between each output to  $V_{CC}$ . (See Fig.4)
- iii) In case of mounted on radiators, do not use silicon rubber.

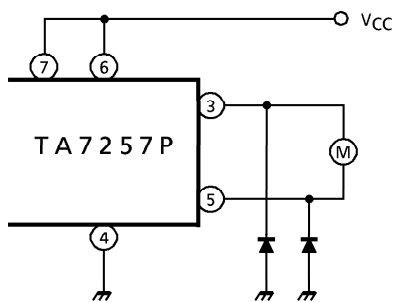

Fig.3

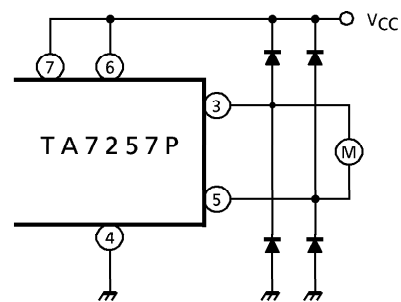
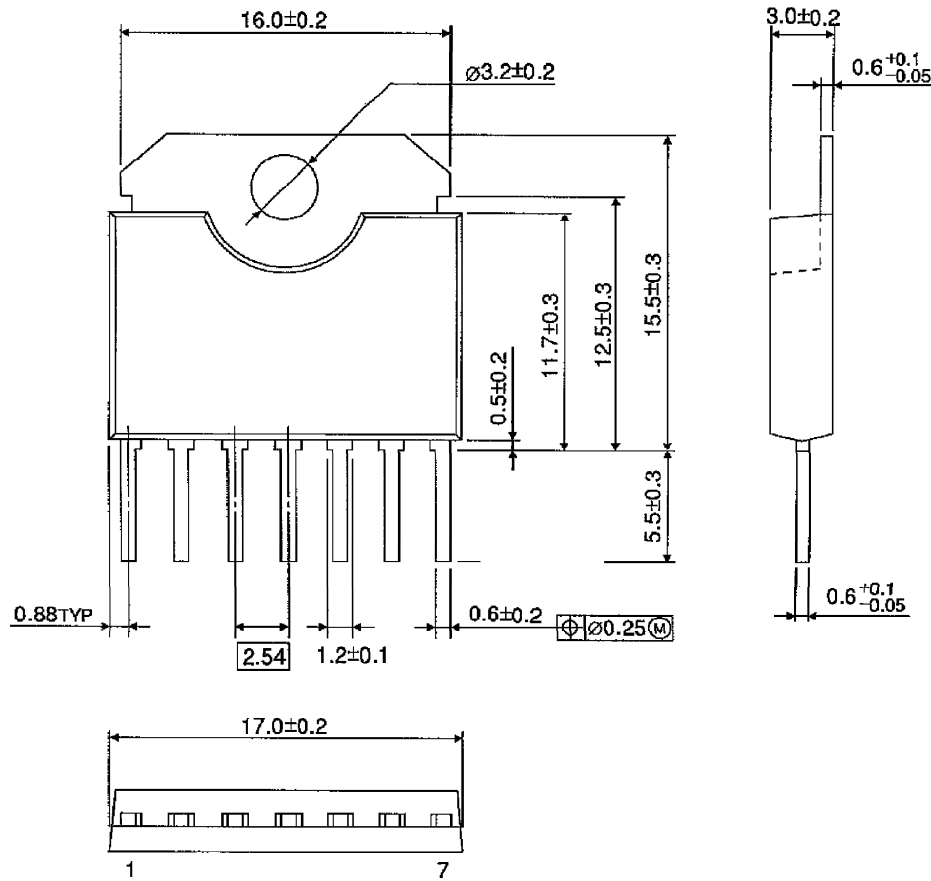

Fig.4

**OUTLINE DRAWING**  
HSIP7-P-2.54

Unit : mm



Weight : 1.88 g (Typ.)