

---

# nRF24L01 Evaluation System nRF24L01-EVSYSTEM

---

## INTRODUCTION

This document describes the nRF24L01 EVSYSTEM and its use with the Nordic Semiconductor nRF24L01 REFMOD.

## GETTING STARTED

The nRF24L01 EVSYSTEM consists of two boards; a Basic Feature Board (BFB) and a Micro Controller Unit (MCU) module. The BFB contains power supply, connectors, battery holder, LEDs and buttons in order to supply the EVSYSTEM with commonly used features. The MCU module is connected to the BFB through a 40 pin dual in line socket. The MCU module contains a C8051F320 MCU which runs the firmware that comes with the nRF24L01 EVKIT.

The nRF24L01 EVSYSTEM must be connected to a PC running the nRF24L01EC software in order to be configured. A description of test setups with the nRF24L01 EVSYSTEM is described in the “nRF24L01 Test Setup” document.

The schematics of the BFB and MCU module are shown in appendix 1.

## nRF24L01 EVSYSTEM DESCRIPTION

The nRF24L01 REFMOD can be plugged into the nRF24L01 EVSYSTEM as shown in Figure 1. The nRF24L01 Evaluation and Configuration software that is required to run the nRF24L01 EVSYSTEM is documented in the nRF24L01EC user guide.

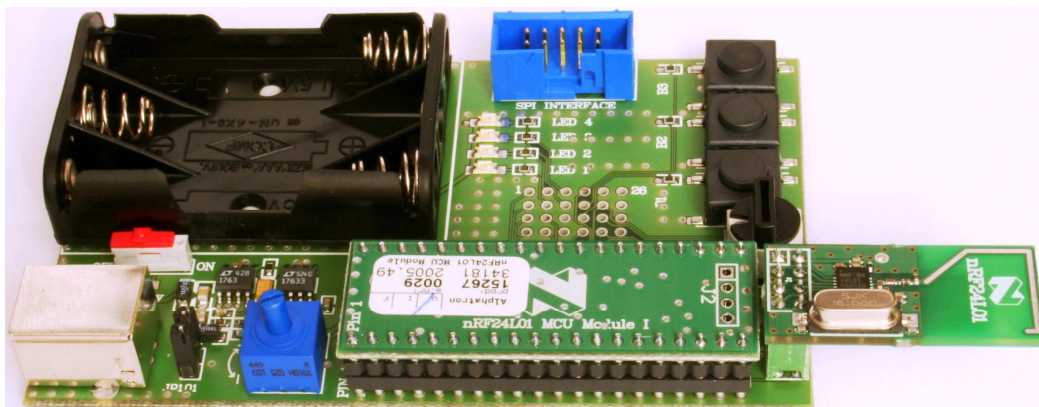

Figure 1: nRF24L01 EVSYSTEM with nRF24L01 REFMOD connected



This board is meant as an aid in the early stages of evaluation and protocol testing. It facilitates device configuration, ShockBurst™ and Enhanced ShockBurst communication.

### Features of the BFB

#### Power supply:

The nRF24L01 EVSYSTEM BFB has two power supply options:

1. Through the USB cable
2. From the 3x AAA battery pack.

The switch close to the battery pack must be set to “ON” to enable supply from the battery. If the USB cable is connected, the power will be sourced from the USB even if the battery switch is set to “ON”.

The nRF24L01 EVSYSTEM BFB has two power regulators, one fixed at 3.0 Volts and one adjustable. The fixed regulator supplies the MCU module and the adjustable supplies the nRF24L01 REFMOD. The adjustable regulator output voltage can be varied from 1.9V to 3.6V with the potential meter. It is possible to measure the voltage over pin 1 and 2 on J2 or with the nRF24L01EC software.

#### LED:

There are four yellow LEDs on the nRF24L01 EVSYSTEM BFB. These LEDs are connected to the MCU module and used to indicate status. Please refer to Table 3 for connection details. The usage of these LEDs is described in the “nRF24L01 Test Setup” document.

The green LED on the nRF24L01 EVSYSTEM BFB indicates the state of the battery switch. If it is lit, the battery switch is on.

#### Buttons:

There are three buttons on the nRF24L01 EVSYSTEM BFB that are connected to the MCU module. Please refer to Table 3 for connection details. These are used to give input to the MCU during tests. How to use them are described in the “nRF24L01 Test Setup” document.

#### Rotary Switch:

The rotary switch is used to set an unique USB identifier on the nRF24L01 EVSYSTEM. This identifier is used to distinguish between different nRF24L01 EVSYSTEM boards connected to the same PC. If multiple nRF24L01 EVSYSTEM boards are going to be connected to the same PC at the same time, ensure that each board has its rotary switch set to a value different from the other boards.

#### SPI Interface:

This connector can be used to connect a logic analyzer to the same SPI bus as the nRF24L01 REFMOD is connected to. It will then be possible to monitor the SPI traffic and control signal handling between the nRF24L01 and the MCU. The pin out of this connector is shown in Table 1.



Pin Number	Signal name	Description
1	RF_VDD	Supply voltage to nRF24L01
2		Not used
3	CE	Chip Enable signal to nRF24L01
4	CSN	SPI CSN
5	MISO	SPI MISO
6	IRQ	IRQ signal from nRF24L01
7	MOSI	SPI MOSI
8	SCK	SPI SCK
9		Not used
10	GND	Common ground

Table 1: Pin out of the SPI interface connector

**JP101:**

The JP101 is a jumper in series with the supply voltage to the nRF24L01 REFMOD. By replacing this jumper with an ampere meter it is possible to measure the current drawn by the nRF24L01 in any operating mode.

**MCU module connector:**

A 40 pin dual in line socket is used to connect a MCU module to the nRF24L01 EVSYSTEM. The pin out for this connector is given in Table 2.

Pin Number	Signal name	Description	Connected to
1	GND	Common ground	
2	P1.0	GPIO	LED 1
3	P1.1	GPIO	LED 2
4	P1.2	GPIO	LED 3
5	P1.3	GPIO	LED 4
6	P1.4	GPIO	
7	P1.5	GPIO	
8	P1.6	GPIO	
9	P0.6	GPIO	
10	GND	Common ground	
11	P2.0	GPIO	
12	P2.1	GPIO	Button B1
13	P2.2	GPIO	Button B2
14	P2.3	GPIO	Button B3
15	P2.4	GPIO	Rotary switch
16	P2.5	GPIO	Rotary switch
17	P2.6	GPIO	Rotary switch
18	P2.7	GPIO	Rotary switch
19	GND	Common ground	
20	SPARE 6	Not used	
21	SPARE 5	Not used	
22	SPARE 4	Not used	
23	SPARE 3	Not used	
24	SPARE 2	Not used	
25	SPARE 1	Not used	
26	GND	Common ground	



Pin Number	Signal name	Description	Connected to
27	VBUS	USB supply voltage input	USB Connector
28	VDD	Regulated voltage input	Output of fixed reg.
29	GND	Common ground	
30	D-	USB D- signal	USB Connector
31	D+	USB D+ signal	USB Connector
32	GND	Common ground	
33	SCK	SPI SCK	
34	MISO	SPI MISO	
35	MOSI	SPI MOSI	
36	CSN	SPI CSN	
37	CE	nRF24L01 CE	
38	IRQ	nRF24L01 IRQ	
39	VDD REG RF	Regulated VDD to nRF24L01	Output of variable reg.
40	P0.7	GPIO	Battery Switch

Table 2: MCU connector pin out

It is possible to replace the supplied MCU module with a proprietary MCU module. The proprietary MCU module must follow the pin out shown in Table 2. The power to the MCU module can be drawn from the “VDD” or “VBUS.”

**Signal grid**

The signal grid is a grid of 5 x 6 trough-hole pads. All signals that is present on the BFB are routed trough this grid. The pin out is shown in Table 3.

Pin Number	Signal name	Description	Connected to
1	P0.7		Battery Switch
2	VDD_REG_RF	Regulated VDD to nRF24L01	Output of variable reg.
3	IRQ	nRF24L01 IRQ	
4	CE	nRF24L01 CE	
5	CSN	SPI CSN	
6	P1.1	GPIO	LED 2
7	P1.0	GPIO	LED 1
8	SCK	SPI SCK	
9	MISO	SPI MISO	
10	MOSI	SPI MOSI	
11	P1.2	GPIO	LED 3
12	P1.3	GPIO	LED 4
13	P1.6	GPIO	
14	P1.5	GPIO	
15	P1.4	GPIO	
16	P2.3	GPIO	Button B3
17	P2.2	GPIO	Button B2
18	P2.1	GPIO	Button B1
19	P2.0	GPIO	
20	P0.6	GPIO	
21	SPARE 6	Not used	
22	P2.7	GPIO	Rotary switch
23	P2.6	GPIO	Rotary switch
24	P2.5	GPIO	Rotary switch
25	P2.4	GPIO	Rotary switch
26	SPARE 5	Not used	
27	SPARE 4	Not used	



Pin Number	Signal name	Description	Connected to
28	SPARE 3	Not used	
29	SPARE 2	Not used	
30	SPARE 1	Not used	

Table 3: Pin out of the signal grid

**nRF24L01 Connector (J2)**

This is the connector where the nRF24L01 REFMOD must be connected. The pin out of this connector is shown in Table 4.

Pin Number	Signal name	Description
1	GND	Common ground
2	RF_VDD	Supply voltage to nRF24L01
3	CE	Chip Enable signal to nRF24L01
4	CSN	SPI CSN
5	SCK	SPI SCK
6	MOSI	SPI MOSI
7	MISO	SPI MISO
8	IRQ	IRQ signal from nRF24L01

Table 4: Pin out of J2

**MCU Module**

The supplied MCU module is equipped with a C8051F320 MCU from Silicon Laboratories. This MCU has both a SPI interface and a USB interface. It runs the firmware for the nRF24L01 EVKIT.

It is possible to replace the firmware in the MCU with two methods:

1. Firmware upgrade in the nRF24L01EC software. This should only be done when receiving a new version of the firmware from Nordic Semiconductor ASA.
2. By using the programming interface, “J2,” on the MCU module. This can be desired when developing a proprietary application. The programming interface is compatible with the C8051F320DK from Silicon Laboratories.



APPENDIX 1

Basic Feature Board

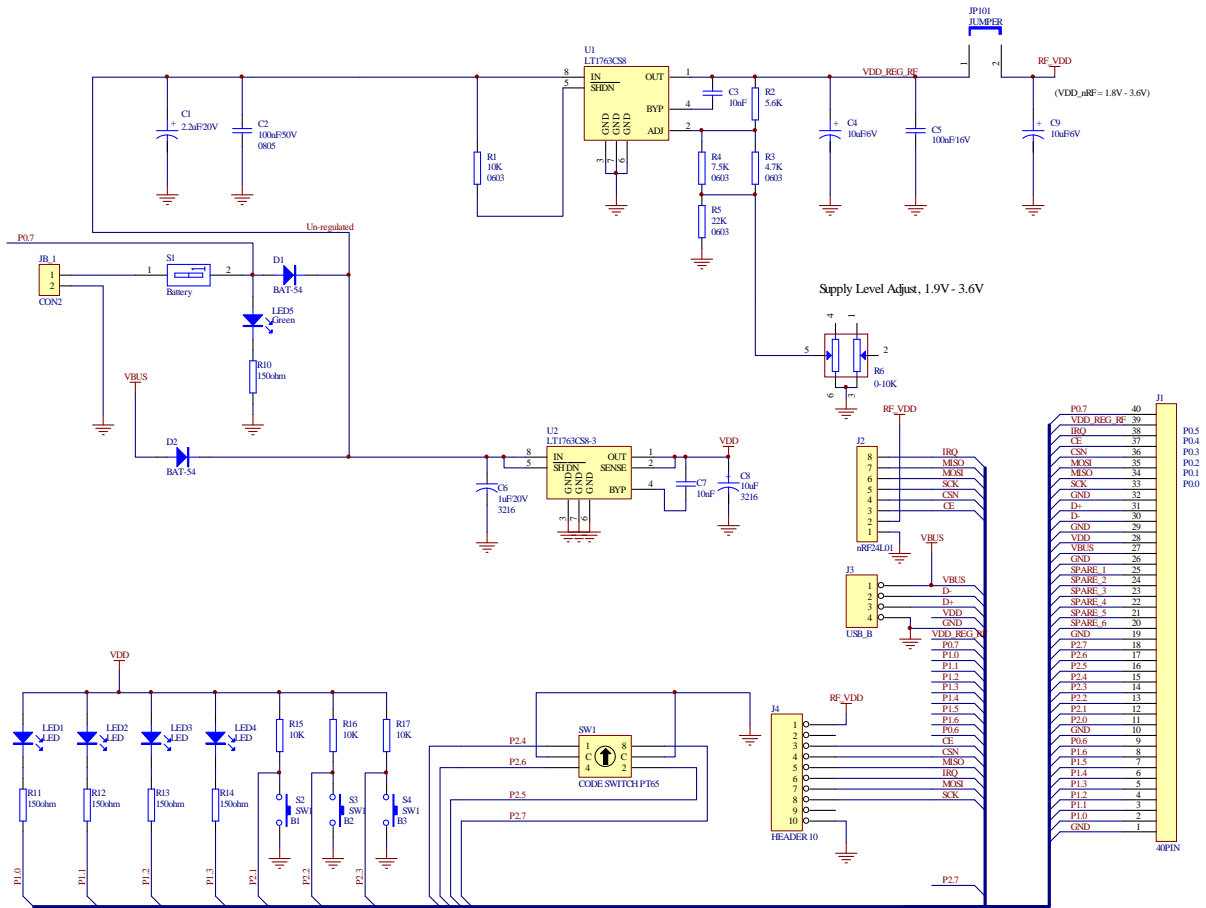

Figure 2: Schematics of the nRF24L01 EVSYSTEM Basic Feature Board



MCU module

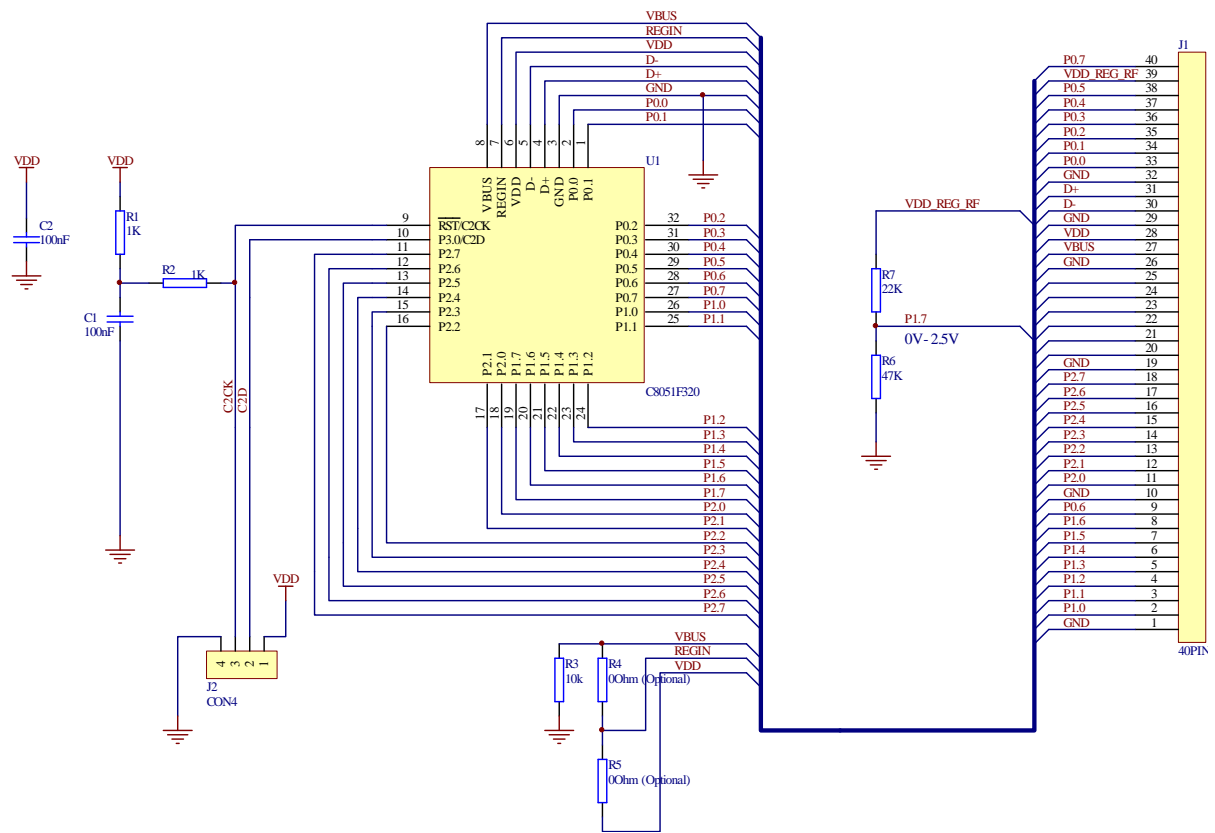

Figure 3: Schematics of the MCU module in the nRF24L01 EVSYSTEM



### **LIABILITY DISCLAIMER**

Nordic Semiconductor ASA reserves the right to make changes without further notice to the product to improve reliability, function or design. Nordic Semiconductor does not assume any liability arising out of the application or use of any product or circuits described herein.

### **LIFE SUPPORT APPLICATIONS**

These products are not designed for use in life support appliances, devices, or systems where malfunction of these products can reasonably be expected to result in personal injury. Nordic Semiconductor ASA customers using or selling these products for use in such applications do so at their own risk and agree to fully indemnify Nordic Semiconductor ASA for any damages resulting from such improper use or sale.

All rights reserved ®. Reproduction in whole or in part is prohibited without the prior written permission of the copyright holder.





**YOUR NOTES**



**Nordic Semiconductor ASA – World Wide Distributors**

**For Your nearest dealer, please see <http://www.nordicsemi.no>**



**Main Office:**

Vestre Rosten 81, N-7075 Tiller, Norway  
Phone: +47 72 89 89 00, Fax: +47 72 89 89 89

**Visit the Nordic Semiconductor ASA website at <http://www.nordicsemi.no>**

---

