

High Speed CAN (HSC) for Vehicle Applications at 125 Kbps

Foreword—The objective of SAE J2284-1 is to define a level of standardization in the implementation of a 125 Kbps vehicle communication network using the Controller Area Network (CAN) protocol. The goal is to achieve a standard Electronic Control Unit (ECU) Physical Layer, Data Link Layer and media design criteria which will allow ECU and tool manufacturers to satisfy the needs of multiple end users with minimum modification to a basic design. Likewise, end users will benefit in lower ECU cost achieved from the high volumes of the basic design.

TABLE OF CONTENTS

1.	Scope	3
2.	References	3
2.1	Applicable Publications	3
2.2	Related Publications	4
3.	Definitions.....	4
4.	Acronyms	5
5.	System Level Attributes of the Network.....	5
5.1	Message Format	5
5.2	125 Kbps Communication Rate.....	5
5.3	Communication Among 32 ECUs.....	5
5.4	Topology and Termination.....	5
5.5	Unshielded Media	5
5.6	Communication/Survivability Under Faulted Conditions.....	6
5.7	EMC Criteria	6
6.	ECU Requirements.....	6
6.1	Absolute Maximum Ratings.....	6
6.1.1	Direct Voltage Connection.....	6
6.1.2	Unpowered Storage Temperature	6
6.2	DC Operating Parameters.....	7
6.2.1	DC Parameters - Recessive Bus State - Bus Disconnected	7
6.2.2	DC Parameters - Dominant Bus State - Bus Disconnected	7
6.2.3	DC Parameters - Recessive Bus State - Bus Connected.....	7
6.2.4	DC Parameters - Dominant Bus State - Bus Connected.....	8

SAE Technical Standards Board Rules provide that: "This report is published by SAE to advance the state of technical and engineering sciences. The use of this report is entirely voluntary, and its applicability and suitability for any particular use, including any patent infringement arising therefrom, is the sole responsibility of the user."

SAE reviews each technical report at least every five years at which time it may be reaffirmed, revised, or cancelled. SAE invites your written comments and suggestions.

TO PLACE A DOCUMENT ORDER: +1 (724) 776-4970 FAX: +1 (724) 776-0790
SAE WEB ADDRESS <http://www.sae.org>

SAE SAE J2284-1 Issued MAR2002

6.3	ECU Internal Capacitance	8
6.4	Physical Media Parameters	8
6.5	Termination	8
6.6	Connector Parameters	8
6.7	Topology Requirements.....	9
6.7.1	Multiple On-Board ECU Configuration.....	9
6.7.2	Single On-Board ECU Configuration	10
6.8	Off-Board Tool Requirements.....	10
6.8.1	Off-Board Tool Capacitive Load	11
6.8.2	Off-Board Tool Propagation Delay.....	12
6.9	Off-Board Tool Cable Requirements	12
6.9.1	Cable Length	12
6.9.2	Cable Propagation Delay	12
6.9.3	Cable Configuration	12
6.10	Bit Timing Requirements	13
6.10.1	Nominal Bit Time (t_{BIT}).....	13
6.10.2	Time Quantum (t_Q)	13
6.10.3	Synchronization Segment (t_{SYNC_SEG}).....	13
6.10.4	TSEG1 (t_{SEG1})	13
6.10.5	TSEG2 (t_{SEG2})	13
6.10.6	Synchronization Jump Width (t_{SJW}).....	13
6.10.7	Data Sample Point (t_{SAMPLE}).....	13
6.10.8	Data Sample Mode	13
6.10.9	Media Delay (t_{BUS}).....	14
6.10.10	ECU Delay (t_{ECU}).....	14
6.10.11	Propagation Delay (t_{PROP}).....	14
6.10.12	Bit Timing Requirements	14
6.11	ElectroMagnetic Compatibility (EMC).....	15
Table 1	Fault Behavior	6
Table 2	Absolute Maximum Bus Wire Voltage	6
Table 3	DC Parameters -- Recessive Bus State -- Bus Disconnected	7
Table 4	DC Parameters -- Dominant Bus State -- Bus Connected	7
Table 5	DC Parameters -- Recessive Bus State -- Bus Connected.....	7
Table 6	DC Parameters -- Dominant Bus State -- Bus Connected	8
Table 7	Internal Capacitance -- ECU Disconnected	8
Table 8	Physical Media Parameters for Unshielded Twisted Pair	8
Table 9	Termination Characteristics	8
Table 10	Connector Characteristics	8
Table 11	Multiple On-Board ECU Topology Requirements	9
Table 12	Single On-Board ECU Topology Requirements.....	10
Table 13	Off-Board Tool Capacitive Load (without Cable Load)	11
Table 14	Off-Board Tool Propagation Delay (Loop Delay without Cable Delay)	12
Table 15	Off-Board Tool Cable Length.....	12
Table 16	Off-Board Tool Cable Propagation Delay (One-Way Delay without Off-Board Tool Delay)	12
Table 17	CAN Bit Timing -- Min/Max	14
Table 18	CAN Register Settings for Standard Time Quanta	15
Table 19	ECU Parameters Related to Emissions.....	16
Figure 1	Multiple On-Board ECU Configuration.....	9
Figure 2	Single On-Board ECU Configuration	10
Figure 3	Off-Board Tool Parameters	11

1. **Scope**—This document will define the Physical Layer and portions of the Data Link Layer of the ISO model for a 125 Kbps High Speed CAN (HSC) protocol implementation. Both ECU and media design requirements for networks will be specified. Requirements will primarily address the CAN physical layer implementation.

Requirements will focus on a minimum standard level of performance from the High Speed CAN (HSC) implementation. All ECUs and media shall be designed to meet certain component level requirements in order to ensure the HSC implementation system level performance at 125 Kbps. The minimum performance level shall be specified by system level performance requirements or characteristics described in detail in Section 6 of this document.

This document is designed such that if the Electronic Control Unit requirements defined in Section 6 are met, then the system level attributes should be obtainable.

This document will address only requirements which may be tested at the ECU and media level. No requirements which apply to the testing of the HSC implementation as integrated into a vehicle are contained in this document. However, compliance with all ECU and media requirements will increase the possibility of communication compatibility between separately procured components and will greatly simplify the task of successfully integrating a HSC communication system in a vehicle.

2. **References**—This specification takes precedence over all conflicts in the documents cited in this section.

- 2.1 **Applicable Publications**—The following publications form a part of the specification to the extent specified herein. Unless otherwise indicated, the latest revision of SAE publications shall apply.

- 2.1.1 SAE PUBLICATIONS—Available from SAE, 400 Commonwealth Drive, Warrendale, Pa. 15096-0001

SAE J551-4—Test Limits and Methods of Measurement of Radio Disturbance Characteristics of Vehicles and Devices, Broadband and Narrowband, 150 kHz to 1000 MHz

SAE J551-11—Vehicle Electromagnetic Immunity—Off-Vehicle Source

SAE J551-15 —Vehicle Electromagnetic Immunity—Electrostatic Discharge (ESD)

SAE J1113-13—Electromagnetic Compatibility Measurement Procedure for Vehicle Components—Part 13: Immunity to Electrostatic Discharge

SAE J1113-21—Electromagnetic Compatibility Measurement Procedure for Vehicle Components—Part 21: Immunity to Electromagnetic Fields, 10 kHz to 18 GHz, Absorber-Lined Chamber

SAE J1113-41—Limits and Methods of Measurement of Radio Disturbance Characteristics of Components and Modules for the Protection of Receivers used On Board Vehicles

SAE J1213-1—Glossary of Vehicle Networks for Multiplexing and Data Communications

- 2.1.2 ISO PUBLICATIONS—Available from ANSI, 25 West 43rd Street, New York, NY 10036-8002.

ISO 11898:1993/Amd.1:1995(E)—Road Vehicles, Interchange of Digital Information, Controller Area Network (CAN) or High Speed Communication

- 2.1.3 OTHER PUBLICATIONS

Bosch - CAN Specification 2.0, Part A and B

2.2 Related Publications—The following publications are for information purposes only and are not a required part of this specification.

2.2.1 SAE PUBLICATIONS—Available from SAE, 400 Commonwealth Drive, Warrendale, Pa. 15096-0001

SAE J1930—Electrical/Electronic Systems Diagnostic Terms, Definitions, Abbreviations and Acronyms
SAE J2190—Enhanced Diagnostic Test Modes
SAE 970295—CAN Bit Timing Requirements

2.2.2 ISO PUBLICATIONS—Available from ANSI, 25 West 43rd Street, New York, NY 10036-8002.

ISO 7498—Data processing systems, Open systems interconnection standard reference manual
ISO 7637/1—Road vehicles, Electrical disturbance by conduction and coupling
ISO 14229—Road vehicles, Diagnostic systems, Specification of diagnostic services

2.2.3 OTHER PUBLICATIONS

CISPR 25 - Limits & Methods of Measurement of Radio Disturbance Characteristics for the Protection of Receivers Used On-Board Vehicles

3. Definitions—The definitions provided in SAE J1213-1 apply to this document. Additional or modified definitions, acronyms, and abbreviations included in this document or relevant to the communication of information in a vehicle are catalogued in this section.

3.1 CAN_H—The CAN_H bus wire is fixed to a mean voltage level during the recessive state and is driven in a positive voltage direction during the dominant bit state.

3.2 CAN_L—The CAN_L bus wire is fixed to a mean voltage level during the recessive state and is driven in a negative voltage direction during the dominant bit state.

3.3 Data Link Layer—Provides the reliable transfer of information across the Physical Layer. This includes message qualification and error control.

3.4 Data Link Connector (DLC)—Provides the electrical connection between Off-Board and On-Board ECUs. For some vehicles, the DLC is the SAE J1962 connector.

3.5 Dominant State—The dominant state is represented by a differential voltage greater than a minimum threshold between the CAN_L and CAN_H bus wires. The dominant state overwrites the recessive state and represents a logic “0” bit value.

3.6 Electronic Control Unit (ECU)—A On- or Off-vehicle electronic assembly from which CAN SAE J2284-1 messages may be sent and/or received.

3.7 Media—The physical entity which conveys the electrical (or equivalent means of communication) transmission between ECUs on the network. (e.g., unshielded twisted pair wires)

3.8 Physical Layer—Concerns the transmission of an unstructured bit stream over physical media: deals with the mechanical, electrical, functional and procedural characteristics to access the physical media.

3.9 Protocol—Formal set of conventions or rules for the exchange of information between ECUs. This includes the specification of frame administration, frame transfer and physical layer.

3.10 Radiated Emissions—Radiated Emissions consists of energy that emanate from the CAN bus wires. Electric field strength in dbmV/m is the typical measure of radiated emissions.

3.11 Radiated Immunity—A property that ensures that the CAN bus wires will not suffer degraded functional operation within its intended electromagnetic environment .

3.12 Recessive State—The recessive state is represented by an inactive state differential voltage that is approximately 0. The recessive state represents a logic “1” bit value.

4. Acronyms

CAN	Controller Area Network
DLC	Data Link Connector
EMC	ElectroMagnetic Compatibility
ESD	ElectroStatic Discharge
HSC	High Speed CAN
Kbps	Kilobits per second
ISO	International Standards Organization
OBD-II	On Board Diagnostics (level 2)
SAE	Society of Automotive Engineers

5. System Level Attributes of the Network—This section describes System Level performance attributes of a 125 Kbps HSC network for automotive vehicle applications. This HSC network is based on ISO 11898:1993 and Amendment 1:1995 with the modifications and additions described as follows.

5.1 Message Format—All ECU CAN interfaces shall, at a minimum, conform to the Bosch “CAN Specification 2.0 Part A” dated September, 1991. In particular, all CAN chips shall implement “enhanced timing” as specified in section 9.1 of the Bosch document.

All ECUs that utilize the 11-bit standard frame identifier shall be, at a minimum, passive to the 29-bit extended message identifier. All SAE J2284-1 compliant ECUs that support OBD-II requirements shall fully support a 29bit extended message identifier.

The encoding of the 11-bit identifier field shall be manufacturer specific. The CAN requirement (see Bosch CAN 2.0 and ISO 11898 CAN documents) specifying that, “the 7 most significant bits (ID-10 - ID-4) must not be all recessive,” shall not be enforced in hardware by SAE J2284-1.

The maximum message frame shall consist of the CAN identifier (CANID) plus 8 data bytes.

5.2 125 Kbps Communication Rate—The network shall operate at a single communication rate of 125 Kbps.

5.3 Communication Among 32 ECUs—The network system shall support the transfer of information among as many as 32 ECUs, and as few as two ECUs.

5.4 Topology and Termination—The wiring topology of this network shall support a linear structure, including daisy chain configurations. Termination shall always be located at each end of the bus. The topology details are specified in 6.7.

5.5 Unshielded Media—The network shall operate using a shielded or unshielded twisted wire pair.

5.6 Communication/Survivability Under Faulted Conditions—See Table 1.

TABLE 1—FAULT BEHAVIOR

Description of Failure	Communication Behavior
One non-terminating ECU becomes disconnected from the bus	Remaining ECUs continue to communicate with no degradation. (exception = daisy chained network)
ECU loss of power or ground (includes low battery condition)	Remaining ECUs continue to communicate with no degradation.
CPU goes into reset, while its physical layer and IC is still powered	Remaining ECUs continue to communicate with no degradation.
CAN_H wire open	Data communication between ECUs on opposite sides of an interruption is not required. Data communication between ECUs on the same side of an interruption may be possible with reduced signal to noise ratio.
CAN_L wire open	Data communication between ECUs on opposite sides of an interruption is not required. Data communication between ECUs on the same side of an interruption may be possible with reduced signal to noise ratio.
CAN_H shorted to battery	Data communication is not required if V _{batt} is greater than the maximum allowed common mode voltage.
CAN_L shorted to battery	Data communication is not required.
CAN_H shorted to ground	Data communication is not required.
CAN_L shorted to ground	Data communication may be possible with reduced signal to noise ratio.
CAN_H shorted to CAN_L	Data communication is not required.
Loss of one termination	Data communication may be possible with reduced signal to noise ratio.

5.7 EMC Criteria—The ECU EMC requirements as specified in 6.11 are intended to satisfy vehicle level EMC compliance when tested in accordance with SAE J551-4, SAE J551-11, and SAE J551-15.

6. ECU Requirements—This section describes the electrical requirements for an ECU on an HSC network. The requirements described are designed to support the design goals described in Section 5 System Level Attributes.

6.1 Absolute Maximum Ratings—The ECU shall not be guaranteed to perform network communication under these conditions. However, network related electrical components within the ECU shall not suffer permanent damage.

6.1.1 DIRECT VOLTAGE CONNECTION—The limits given in Table 2 are the absolute maximum and minimum DC voltages which can be connected to the bus wires without damage to the ECU.

TABLE 2—ABSOLUTE MAXIMUM BUS WIRE VOLTAGE

Symbol	Minimum	Maximum	Units	Conditions
CAN_L	-3.0	+16.0	VOLTS	12 Volt System
CAN_H	-3.0	+16.0	VOLTS	12 Volt System

6.1.2 UNPOWERED STORAGE TEMPERATURE—The SAE J2284-1 electrical components within the ECU shall not suffer permanent damage if subjected to storage temperatures between -40 °C and +150 °C.

6.2 DC Operating Parameters—DC parameters shall be within the defined ranges for four unique conditions:

- a. Recessive Bus State, ECU disconnected from CAN Bus
- b. Dominant Bus State, ECU disconnected from CAN Bus
- c. Recessive Bus State, ECU connected to maximum CAN Bus
- d. Dominant Bus State, ECU connected to maximum CAN Bus

Compliance with the defined voltage ranges shall insure that ECUs will operate in a vehicle network application which guarantees a maximum of 2 volts DC ground offset between any two ECUs. Compliance shall be maintained over the following ECU operating ranges:

High Temperature –40 °C to +125 °C
 Low Temperature –40 °C to +85 °C

6.2.1 DC PARAMETERS - RECESSIVE BUS STATE - BUS DISCONNECTED—See Table 3.

TABLE 3—DC PARAMETERS—RECESSIVE BUS STATE—BUS DISCONNECTED

Symbol	Minimum	Nominal	Maximum	Units	Conditions
CAN_H	2.0	2.5	3.0	Volts	no load
CAN_L	2.0	2.5	3.0	Volts	no load
V _{OUT-DIFF(H-L)}	-500		50	Millivolts	no load
R _{DIFF}	10		100	KΩ	no load ⁽¹⁾
R _{IN}	5		50	KΩ	no load
V _{IN-DIFF(H-L)}	-1.0		0.5	Volts	⁽²⁾

- 1. For termination ECUs this value is measured with the termination depopulated.
- 2. The equivalent of two 120 Ω terminating resistors in parallel is connected between CAN_H and AN_L (=600 Ω).

6.2.2 DC PARAMETERS - DOMINANT BUS STATE - BUS DISCONNECTED—See Table 4.

TABLE 4—DC PARAMETERS—DOMINANT BUS STATE—BUS CONNECTED

Symbol	Minimum	Nominal	Maximum	Units	Conditions
CAN_H	2.75	3.5	4.5	Volts	⁽¹⁾
CAN_L	0.5	1.5	2.25	Volts	
V _{OUT-DIFF(H-L)}	1.5	2.0	3.0	Volts	⁽¹⁾
V _{IN-DIFF(H-L)}	0.9		5.0	Volts	⁽¹⁾

- 1. The equivalent of two 120 Ω terminating resistors in parallel is connected between CAN_H and CAN_L (=60 Ω).

6.2.3 DC PARAMETERS - RECESSIVE BUS STATE - BUS CONNECTED—See Table 5.

TABLE 5—DC PARAMETERS—RECESSIVE BUS STATE—BUS CONNECTED

Symbol	Minimum	Nominal	Maximum	Units	Conditions
CAN_H		2.5	7.0	Volts	Reference ECU Gnd
CAN_L	-2.0	2.5		Volts	Reference ECU Gnd
V _{OUT-DIFF(H-L)}	-120	0	12	mV	Reference ECU Gnd

6.2.4 DC PARAMETERS - DOMINANT BUS STATE - BUS CONNECTED—See Table 6.

TABLE 6—DC PARAMETERS—DOMINANT BUS STATE—BUS CONNECTED

Symbol	Minimum	Nominal	Maximum	Units	Conditions
CAN_H		3.5	7.0	Volts	Reference ECU Gnd
CAN_L	-2.0	1.5		Volts	Reference ECU Gnd
V _{OUT-DIFF(H-L)}	1.2	2.0	3.0	Volts	

6.3 ECU Internal Capacitance—See Table 7.

TABLE 7—INTERNAL CAPACITANCE—ECU DISCONNECTED

Symbol	Minimum	Nominal	Maximum	Units	Conditions
CAN_H			100	Picofarads	
CAN_L			100	Picofarads	
C _{DIFF}			50	Picofarads	

6.4 Physical Media Parameters—See Table 8.

TABLE 8—PHYSICAL MEDIA PARAMETERS FOR UNSHIELDED TWISTED PAIR

Symbol	Minimum	Nominal	Maximum	Units	Conditions
Z	108	120	132	Ω	
R _{LENGTH}			70	mΩ/meter	
t _{DELAY}			5.5	ns/meter	
RATE _{TWIST}	33		50	Twists/meter	

6.5 Termination—The bus shall be terminated with an appropriate resistance to provide correct loading impedance for the CAN_H and CAN_L wires. This termination resistance shall be connected between the CAN_H and CAN_L conductors. Each of two termination resistors is required to meet the requirements. Location of the termination resistance on the CAN bus shall be as specified in 6.7 and 6.8.

TABLE 9—TERMINATION CHARACTERISTICS

Symbol	Minimum	Nominal	Maximum	Units	Conditions
R _L	118	120	132	Ω	each termination resistor ⁽¹⁾
PWR _L	220			Milliwatts	each termination resistor

1. Split termination implementations are allowed.

6.6 Connector Parameters—The characteristic impedance of the CAN_H and CAN_L connector pins should match the impedance of the wire (see Table 8). Additional requirements for all connectors conveying the CAN signals are shown in Table 10:

TABLE 10—CONNECTOR CHARACTERISTICS

Parameter	Symbol	Minimum	Nominal	Maximum	Units
Voltage	CAN_H, CAN_L			+16.0	Volts
Current	I		25	80	mA
Peak Current	I _{peak}			500	mA
Contact Resistance	R _t		70	100 ⁽¹⁾	mΩ

1. See also ISO 11898 Sections 10.5.2 and 10.5.3.

6.7 Topology Requirements—The wiring topology of this network supports a linear structure. The supporting topology requirements are shown as follows. Note that the connection to an Off-Board Tool is optional.

6.7.1 MULTIPLE ON-BOARD ECU CONFIGURATION—The topology requirements for a network containing more than one ECU On-Board the vehicle and a single Off-Board Tool are specified in Figure 1 and Table 11:

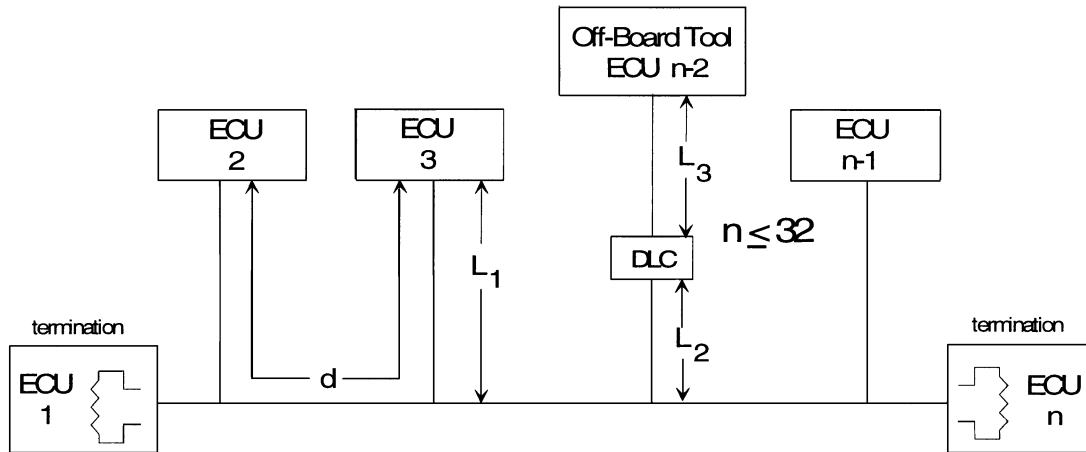

FIGURE 1—MULTIPLE ON-BOARD ECU CONFIGURATION

TABLE 11—MULTIPLE ON-BOARD ECU TOPOLOGY REQUIREMENTS

Parameter	Symbol	Minimum	Nominal	Maximum	Unit	Comments
ECU Cable Stub length	L_1	0		1	meter	Minimum of 0 allows for daisy chain configurations.
In-Vehicle DLC Cable Stub Length	L_2	0		1	meter	Minimum of 0 allows for daisy chain configurations.
Off-Board DLC Cable Stub Length	L_3	0		5	meter	See also 6.8
ECU Distance	d	0		50	meter	Distance between any two ECUs on the bus. Including cable stubs and an Off-Board Tool. See also 6.8

Additional Requirements:

- a. To minimize standing waves, ECUs should not be placed equally spaced on the network and cable tail lengths should not all be the same length. The dimensional requirements of the network are shown in Table 11.
- b. The terminations may be placed within modules. Terminations shall be placed adjacent to, or within, the two On-Board ECUs which are located at the greatest bus distance from each other.
- c. Non-terminated ECUs can be optional connections.

6.7.2 SINGLE ON-BOARD ECU CONFIGURATION—The topology requirements for a network containing a single ECU On-Board the vehicle and a single ECU Off-Board the vehicle (e.g., an OBD Scan Tool) are shown in Figure 2 and Table 12:

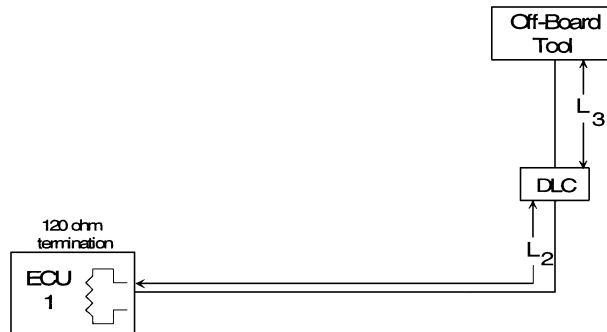

FIGURE 2—SINGLE ON-BOARD ECU CONFIGURATION

TABLE 12—SINGLE ON-BOARD ECU TOPOLOGY REQUIREMENTS

Parameter	Symbol	Minimum	Nominal	Maximum	Unit	Comments
In-Vehicle DLC Cable Stub Length	L_2	0.1		5	meter	
Off-Board DLC Cable Stub Length	L_3	0		5	meter	See also 6.8

Additional Requirements:

- a. A single 120 Ω terminator shall be required at any point on the On-Board portion of the CAN bus.

6.8 Off-Board Tool Requirements—If the SAE J2284-1 bus is to be wired to the DLC, the following requirements must be met:

- a. The Off-Board Tool shall be counted as one of the 32 allowable system ECUs.
- b. The Off-Board Tool shall always be an unterminated node on the CAN network.
- c. The distance between the DLC and any On-Board (ECU) shall be limited to 45 meters.

This section specifies the required electrical parameters (capacitance, propagation delay) to be fulfilled by the Off-Board Tool.

NOTE— This does not include the cable between the Off-Board Tool and the DLC. Cable requirements are specified in 6.9.

6.8.1 OFF-BOARD TOOL CAPACITIVE LOAD—See Figure 3 and Table 13.

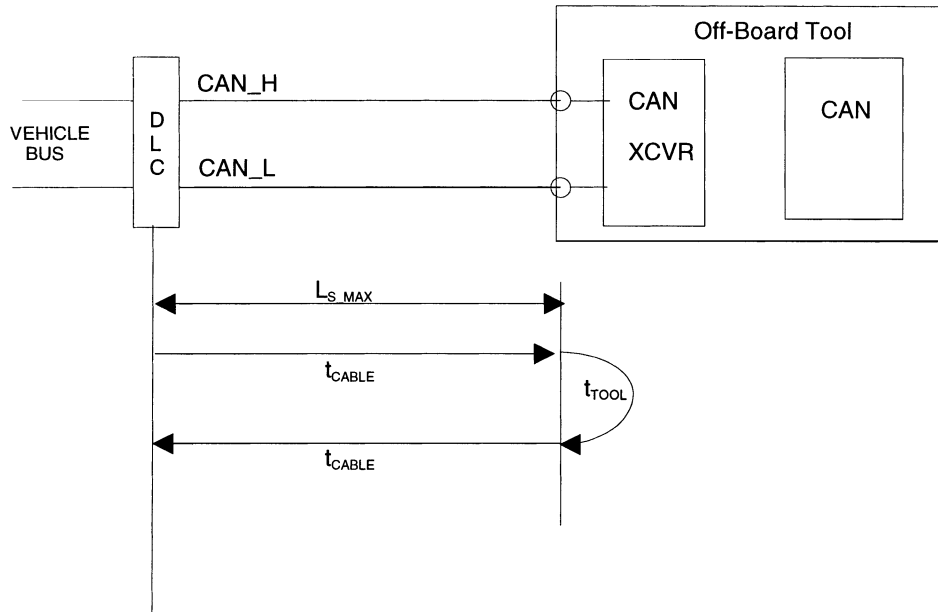

FIGURE 3—OFF-BOARD TOOL PARAMETERS

The specified values for the Off-Board Tool capacitive load do not include the capacitive load of the Off-Board Tool cable.

TABLE 13—OFF-BOARD TOOL CAPACITIVE LOAD (WITHOUT CABLE LOAD)

Term	Min	Nominal	Max	Remark
C_{diff}	—	—	50 pF	CAN_H to CAN_L
C_{CAN_H}, C_{CAN_L}	—	—	100 pF	CAN_H/CAN_L to ground potential

6.8.2 OFF-BOARD TOOL PROPAGATION DELAY—The below given value for the Off-Board Tool propagation delay does not include the cable propagation delay. This requirement is based upon the most critical timing when operating at the baud rate of 125 kbit/s. The Off-Board Tool propagation delay (loop delay) includes the following four delays (see Table 14):

- a. Transmitter propagation delay (t_{TX} , this includes device delay and slew)
- b. Receiver propagation delay (t_{RX})
- c. Receiver Logic delay (t_{LOGIC})
- d. Common Mode Choke (t_{CHK} , optional, includes both Tx and Rx choke delays)

$$t_{TOOL} = (t_{TX} + t_{RX} + t_{LOGIC} + t_{CHK}) \quad (\text{Eq. 1})$$

**TABLE 14—OFF-BOARD TOOL PROPAGATION DELAY
(LOOP DELAY WITHOUT CABLE DELAY)**

Term	Min	Nominal	Max	Remark
t_{TOOL}	—	—	390 ns	Loop Delay of Off-Board Tool

6.9 Off-Board Tool Cable Requirements—The Off-Board Tool cable shall provide interconnection between the vehicle DLC and the CAN interface of the Off-Board Tool (see 6.8).

6.9.1 CABLE LENGTH—The Off-Board Tool cable length is defined to be the length of the cable between the DLC and the Off-Board Tool CAN interface. (See Table 15.)

TABLE 15—OFF-BOARD TOOL CABLE LENGTH

Term	Min.	Nominal	Max.	Remark
L_{S_MAX}	—	—	5 m	Off-Board Tool cable length

6.9.2 CABLE PROPAGATION DELAY—The cable propagation delay is defined as a one-way delay. (See Table 16.)

**TABLE 16—OFF-BOARD TOOL CABLE PROPAGATION DELAY
(ONE-WAY DELAY WITHOUT OFF-BOARD TOOL DELAY)**

Term	Min.	Nominal	Max.	Remark
t_{CABLE}	—	—	30 ns	Off-Board Tool cable delay

6.9.3 CABLE CONFIGURATION—The following requirements apply to the Off-Board Tool cable:

- a. No other wires shall be twisted with either CAN conductor CAN_H or CAN_L.
- b. The CAN_H and CAN_L conductors shall be of the same length, traverse the same path for the entire distance
- c. CAN_H and CAN_L conductors shall not be included in any wire bundle containing radiating wires which induce more than 0.5 volts differential signal between the CAN_H and CAN_L conductors.
- d. The Off-Board cable may be shielded. If it is shielded, the shield shall be grounded at one end only.
- e. The Off-Board Tool cable shall have no requirement for twisting or characteristic impedance value.

6.10 Bit Timing Requirements—Timing synchronization between modules shall be controlled by specification of the nominal bit time (inverse of bit rate), synchronization jump width, data sample point in the bit period, and the data sample mode. The bit period corresponds to the amount of time that a single NRZ data bit is logically driven onto the CAN bus. The data sample mode refers to the number of data samples taken within the bit period which are used to determine the NRZ data value on the CAN bus. The data sample point refers to the time period as measured from the start of the bit period to the point in the bit period where the NRZ data value is sampled. The synchronization jump width refers to the maximum amount of time by which a bit period may be shortened or lengthened to compensate for differences in bit periods and propagation delays between different ECUs on the network.

The tables below specify timing requirements and briefly indicate the conditions which determine the minimum and maximum values required for SAE J2284-1 HSC implementation compliance.

- 6.10.1 **NOMINAL BIT TIME (t_{BIT})**—Compliance with the nominal bit time tolerance requirement is directly dependent on the system clock tolerance of the module and the programmed nominal bit time. In the typical CAN protocol device, the nominal bit time must be an integer multiple of the system clock period. When the programmable nominal bit period is set to exactly 125 Kbps, accuracy is only affected by the system clock tolerance. Otherwise, the accuracy is dependent upon both the deviation of the programmed bit period from nominal and the system clock tolerance. The contributions from drift or aging of the system clock source and contributions from inability to achieve the desired 8000 ns nominal value are additive; the tolerance specification must be met after consideration of both.
- 6.10.2 **TIME QUANTUM (t_Q)**—This is the basic unit of time for bit timing. This time is derived from the system's oscillator clock and is programmable based on the system's divide register values.
- 6.10.3 **SYNCHRONIZATION SEGMENT (t_{SYNC_SEG})**—This time interval is used to synchronize all ECUs on the bus. If all ECUs are fully synchronized, then all bit edges occur in this interval, which has a fixed period of one Time Quantum.
- 6.10.4 **TSEG1 (t_{SEG1})**—This time interval is used to compensate for positive phase errors in synchronization between ECUs on the network. If an edge occurs during this interval, t_{SEG1} is lengthened to compensate for synchronization differences with other ECUs on the CAN network. **TSEG1 is equivalent to the combination of the Prop_Seg and Phase_Seg1 parts of the bit period defined in ISO 11898.**
- 6.10.5 **TSEG2 (t_{SEG2})**—This time interval is used to compensate for negative phase errors in synchronization between ECUs on the network. If an edge occurs during this interval, t_{SEG2} is shortened to compensate for synchronization differences with other ECUs on the CAN network.
- 6.10.6 **SYNCHRONIZATION JUMP WIDTH (t_{SJW})**—This time interval is the maximum amount of time by which t_{SEG1} may be lengthened or t_{SEG2} shortened to compensate for synchronization differences between ECUs on the CAN network. This is accomplished automatically in the CAN device as a basic part of the protocol. However, the amount of skew tolerated is adjustable by software programming.
- 6.10.7 **DATA SAMPLE POINT (t_{SAMPLE})**—The sample point is the time within the bit period at which the single data sample captures the state of the bus. The programmable sample point is located between t_{SEG1} and t_{SEG2} . The following equation shows the relationship of t_{SAMPLE} to t_{SEG2} :

$$t_{SAMPLE} = t_{BIT} - t_{SEG2} \quad (\text{Eq. 2})$$

- 6.10.8 **DATA SAMPLE MODE**—The data sampling shall always be set to single sample mode.

6.10.9 MEDIA DELAY (t_{BUS})—Media is defined as all elements between the connector pins of the communicating modules through which the signals pass.

Media delay is defined as the time required for a signal to pass through the media at the longest specified distance (see Table 8 in 6.4, and Table 11, in 6.7).

6.10.10 ECU DELAY (t_{ECU})—An ECU's loop delay includes the following four delays:

- a. Transmitter Propagation Delay (t_{TX} , this includes device delay and slew)
- b. Receiver Propagation Delay (t_{RX})
- c. Receiver Logic Delay (t_{LOGIC})
- d. Common Mode Choke (t_{CHK} , optional, Includes both Tx and Rx choke delays)

$$t_{ECU} = (t_{TX} + t_{RX} + t_{LOGIC} + t_{CHK}) \quad (\text{Eq. 3})$$

6.10.11 PROPAGATION DELAY (t_{PROP})—Because CAN is an arbitrating protocol, the propagation delay must take into account the time required for a signal to make a complete round trip from one module to another and back. This translates to the following equation:

$$t_{PROP} = 2(t_{TX} + t_{RX} + t_{LOGIC} + t_{CHK} + t_{BUS}) \quad (\text{Eq. 4})$$

or

$$t_{PROP} = 2(t_{ECU} + t_{BUS}) \quad (\text{Eq. 5})$$

6.10.12 BIT TIMING REQUIREMENTS—The following table defines the CAN bit timing requirements. Coordinated bit timing settings are required to maintain synchronization between modules during both normal and error conditions. See Table 17.

TABLE 17—CAN BIT TIMING—MIN/MAX

Term	Min	Nominal	Max
$t_{BIT}^{(1)}$	7904 ns (-1.20%)	8000 ns	8096 ns (+1.20%)
$t_{BUS}^{(2)}$	—	—	800 ns
t_{ECU}	50 ns	—	390 ns
t_Q	—	—	1000 ns
t_{SEG1}	(3)	(3)	(3)

1. The nominal bit time must be a programmable, integer multiple of the system clock periods.
2. t_{BUS} one roundtrip through 50 m
3. $t_{SEG1} = t_{BIT} - 1(t_Q) - t_{SEG2}$

Table 18 defines compliant bit timing settings for time quanta which meet system assumptions outlined in Section 5.

TABLE 18—CAN REGISTER SETTINGS FOR STANDARD TIME QUANTA

NQ	t _Q	t _{SJW}	t _{SEG2min}	t _{SEG2max}
13	615 ns	2460 ns	2460 ns	3075 ns
12	667 ns	2667 ns	2667 ns	3333 ns
11	727 ns	2908 ns	2908 ns	2908 ns
10	800 ns	3200 ns	3200 ns	3200 ns
8	1000 ns	3000 ns	3000 ns	3000 ns

Bit settings for previous time quanta were calculated using the following equations:

NOTE—t_{BIT} is always set to 8000 ns. If the module is unable to be programmed to allow t_{BIT} nominal to be equal to 8000 ns, the offset should be taken into account in the Δf term not the t_{BIT} term.

$$t_{SJW} \geq \text{maximum of } \frac{20t_{BIT}\Delta f}{1 - \Delta f} \text{ or } \frac{\Delta f(20t_{BIT} - t_Q) + t_Q - t_{PROP\ min}}{1 + \Delta f} \quad (\text{Eq. 6})$$

$$t_{SEG2min} \geq \text{maximum of } t_{SJW} \text{ or } 2t_Q \quad (\text{Eq. 7})$$

$$t_{SEG2max} \leq \text{minimum of } \frac{t_{BIT}(1 - 25\Delta f) - t_{PROPmax}}{1 - \Delta f} \text{ or } \frac{t_{BIT} - t_{PROPmax} - t_Q - \Delta f(25t_{BIT} - t_Q) + t_{PROPmin}/2}{1 - \Delta f} \quad (\text{Eq. 8})$$

DEFINITION: Δf equals the maximum allowable deviation (either maximum or minimum) from the specified nominal bit rate divided by the specified nominal bit rate. See Table 17 for specified values.

6.11 ElectroMagnetic Compatibility (EMC)—The CAN physical layer, when incorporated into an ECU design, shall function as specified in the ECU's intended electromagnetic environment. Additionally, the electromagnetic emissions produced during CAN related operation shall not interfere with the normal operation of other ECU's or subsystems.

Testing, using the SAE J1113-13, SAE J1113-21, and SAE J1113-41 or equivalent methods, can be used to assess and/or compare the EMC performance of a CAN physical layer design(s).

Recommended testing includes:

- Radiated Immunity
- Radiated Emissions
- Electrostatic Discharge

Formal validation of the CAN physical layer design, however, shall occur during EMC testing of the actual ECU, using test procedures and acceptance criteria specified by the vehicle manufacturer.

The following requirement is optional for Off-Board Tools.

To aid the vehicle manufacturer in predicting radiated emissions performance, the ECU supplier shall provide maximum or minimum value of the parameters indicated by a "****" in Table 19.

TABLE 19—ECU PARAMETERS RELATED TO EMISSIONS

Parameter	Signal	Minimum	Maximum	Units
Recessive to Dominant Transition	t_{R_D}	***		nanoseconds
Dominant to Recessive Transition	t_{D_R}	***		nanoseconds
Differential Output Skew Time	t_{SKEW_DIFF}		***	nanoseconds
Differential Output Amplitude Mismatch	V_{AMP_DIFF}		***	millivolts

NOTE— Skew shall be measured at the 50% point of the voltage transition.
 Rise and fall times shall be measured at 10% and 90% of the voltage transition.

PREPARED BY THE SAE HIGH SPEED CAN IMPLEMENTATION TASK FORCE OF THE
 SAE VEHICLE ARCHITECTURE FOR DATA COMMUNICATIONS STANDARDS

SAE SAE J2284-1 Issued MAR2002

Rationale—Not applicable.

Relationship of SAE Standard to ISO Standard—Not applicable.

Application—This document will define the Physical Layer and portions of the Data Link Layer of the ISO model for a 125 Kbps High Speed CAN (HSC) protocol implementation. Both ECU and media design requirements for networks will be specified. Requirements will primarily address the CAN physical layer implementation.

Requirements will focus on a minimum standard level of performance from the High Speed CAN (HSC) implementation. All ECUs and media shall be designed to meet certain component level requirements in order to ensure the HSC implementation system level performance at 125 Kbps. The minimum performance level shall be specified by system level performance requirements or characteristics described in detail in Section 6 of this document.

This document is designed such that if the Electronic Control Unit requirements defined in Section 6 are met, then the system level attributes should be obtainable.

This document will address only requirements which may be tested at the ECU and media level. No requirements which apply to the testing of the HSC implementation as integrated into a vehicle are contained in this document. However, compliance with all ECU and media requirements will increase the possibility of communication compatibility between separately procured components and will greatly simplify the task of successfully integrating a HSC communication system in a vehicle.

Reference Section

SAE J551-4—Test Limits and Methods of Measurement of Radio Disturbance Characteristics of Vehicles and Devices, Broadband and Narrowband, 150 kHz to 1000 MHz

SAE J551-11—Vehicle Electromagnetic Immunity—Off-Vehicle Source

SAE J551-15 —Vehicle Electromagnetic Immunity—Electrostatic Discharge (ESD)

SAE J1113-13—Electromagnetic Compatibility Measurement Procedure for Vehicle Components—Part 13: Immunity to Electrostatic Discharge

SAE J1113-21—Electromagnetic Compatibility Measurement Procedure for Vehicle Components—Part 21: Immunity to Electromagnetic Fields, 10 kHz to 18 GHz, Absorber-Lined Chamber

SAE J1113-41—Limits and Methods of Measurement of Radio Disturbance Characteristics of Components and Modules for the Protection of Receivers used On Board Vehicles

SAE J1213-1—Glossary of Vehicle Networks for Multiplexing and Data Communications

SAE J1930—Electrical/Electronic Systems Diagnostic Terms, Definitions, Abbreviations and Acronyms

SAE J1962— OBD Diagnostic Connector

SAE J2190—Enhanced Diagnostic Test Modes

SAE 970295—CAN Bit Timing Requirements

ISO 7498—Data Processing Systems, Open Systems Interconnection Standard Reference Model

SAE SAE J2284-1 Issued MAR2002

ISO 11898:1993/Amd.1:1995(E)—Road Vehicles, Interchange of Digital Information, Controller Area Network (CAN) or High Speed Communication

ISO 7637/1—Road Vehicles, Electrical Disturbance by Conduction and Coupling

ISO 14229—Road Vehicles, Diagnostic Systems, Specification of Diagnostic Services

Bosch - CAN Specification 2.0, Part A and B

CISPR 25 - Limits & Methods of Measurement of Radio Disturbance Characteristics for the Protection Of Receivers Used On-Board Vehicles

Developed by the SAE CAN High Speed Implementation Task Force

Sponsored by the SAE Vehicle Architecture for Data Communications Standards Committee