



TMC603 – DATASHEET

Three phase motor driver with BLDC back EMF commutation hallFX™ and current sensing

TRINAMIC® Motion Control GmbH & Co. KG
Sternstraße 67
D – 20357 Hamburg
GERMANY
www.trinamic.com



1 Features

The TMC603 is a three phase motor driver for highly compact and energy efficient drive solutions. It contains all power and analog circuitry required for a high performance BLDC motor system. The TMC603 is designed to provide the frontend for a microcontroller doing motor commutation and control algorithms. It directly drives 6 external N-channel MOSFETs for motor currents up to 30A and up to 50V and integrates shunt less current measurement, by using the MOSFETs channel resistance for sensing. Integrated hallFX (pat. fil.) allows for sensorless commutation. Protection and diagnostic features as well as a step down switching regulator further reduce system cost and increase reliability.

Highlights

- Up to 30A motor current
- 9V to 50V operating voltage
- 3.3V or 5V interface
- 8mm x 8mm QFN package
- Integrated shunt less current measurement using power MOS transistor RDSon
- hallFX™ sensorless back EMF commutation emulates hall sensors
- Integrated break-before-make logic: No special microcontroller PWM hardware required
- EMV optimized current controlled gate drivers – up to 150mA possible
- Overcurrent / short to GND and undervoltage protection and diagnostics integrated
- Internal Q_{GD} protection: Supports latest generation of power MOSFETs
- Integrated supply concept: Step down switching regulator up to 500mA / 300kHz
- Common rail charge pump allows for 100% PWM duty cycle

Applications

- Motor driver for industrial applications
- Integrated miniaturized drives
- Robotics
- High-reliability drives (dual position sensor possible)
- Pump and blower applications with sensorless commutation

Motor type

- 3 phase BLDC, stepper, DC motor
- Sine or block commutation
- Rotor position feedback: Sensorless, encoder or hall sensor, or any mix

Life support policy

TRINAMIC Motion Control GmbH & Co. KG does not authorize or warrant any of its products for use in life support systems, without the specific written consent of TRINAMIC Motion Control GmbH & Co. KG.

Life support systems are equipment intended to support or sustain life, and whose failure to perform, when properly used in accordance with instructions provided, can be reasonably expected to result in personal injury or death.

© TRINAMIC Motion Control GmbH & Co. KG 2008

Information given in this data sheet is believed to be accurate and reliable. However no responsibility is assumed for the consequences of its use nor for any infringement of patents or other rights of third parties which may result from its use.

Specifications subject to change without notice

2 Table of contents

1	FEATURES.....	1
2	TABLE OF CONTENTS	3
3	SYSTEM ARCHITECTURE USING THE TMC603	5
4	PINOUT	6
4.1	PACKAGE CODES	6
4.2	PACKAGE DIMENSIONS QFN52.....	7
5	TMC603 FUNCTIONAL BLOCKS.....	8
5.1	BLOCK DIAGRAM AND PIN DESCRIPTION.....	8
5.2	MOSFET DRIVER STAGE	10
5.2.1	<i>Principle of operation</i>	10
5.2.2	<i>Break-before-make logic</i>	11
5.2.3	<i>PWM control via microcontroller</i>	12
5.2.4	<i>Slope control</i>	13
5.2.5	<i>Reverse capacity (QGD) protection</i>	14
5.2.6	<i>Considerations for QGD protection</i>	15
5.2.7	<i>Effects of the MOSFET bulk diode</i>	16
5.2.8	<i>Adding Schottky diodes across the MOSFET bulk diodes</i>	16
5.2.9	<i>Short to GND detection</i>	17
5.2.10	<i>Error logic</i>	17
5.3	CURRENT MEASUREMENT AMPLIFIERS.....	19
5.3.1	<i>Current measurement timing</i>	19
5.3.2	<i>Auto zero cycle</i>	20
5.3.3	<i>Measurement depending on chopper cycle</i>	20
5.3.4	<i>Compensating for offset voltages</i>	20
5.3.5	<i>Getting a precise current value</i>	20
5.4	HALLFX SENSORLESS COMMUTATION	21
5.4.1	<i>Adjusting the hallFX spike suppression time</i>	21
5.4.2	<i>Adjusting the hallFX filter frequency</i>	22
5.4.3	<i>Block commutation chopper scheme for hallFX</i>	22
5.4.4	<i>Start-up sequence for the motor with forced commutation</i>	23
5.5	POWER SUPPLY.....	25
5.5.1	<i>Switching regulator and charge pump</i>	25
5.5.2	<i>Charge pump</i>	27
5.5.3	<i>Supply voltage filtering</i>	27
5.5.4	<i>Reverse polarity protection</i>	27
5.5.5	<i>Standby with zero power consumption</i>	27
5.5.6	<i>Low voltage operation down to 9V</i>	28
5.6	TEST OUTPUT.....	29
6	ABSOLUTE MAXIMUM RATINGS	30
7	ELECTRICAL CHARACTERISTICS.....	30
7.1	OPERATIONAL RANGE.....	30
7.2	DC CHARACTERISTICS AND TIMING CHARACTERISTICS	31
8	DESIGNING THE APPLICATION	38
8.1	CHOOSING THE BEST FITTING POWER MOSFET	38
8.1.1	<i>Calculating the MOSFET power dissipation</i>	38
8.2	MOSFET EXAMPLES.....	40
8.3	DRIVING A DC MOTOR WITH THE TMC603	40
9	TABLE OF FIGURES	41

10 REVISION HISTORY 41
10.1 DOCUMENTATION REVISION 41

3 System architecture using the TMC603

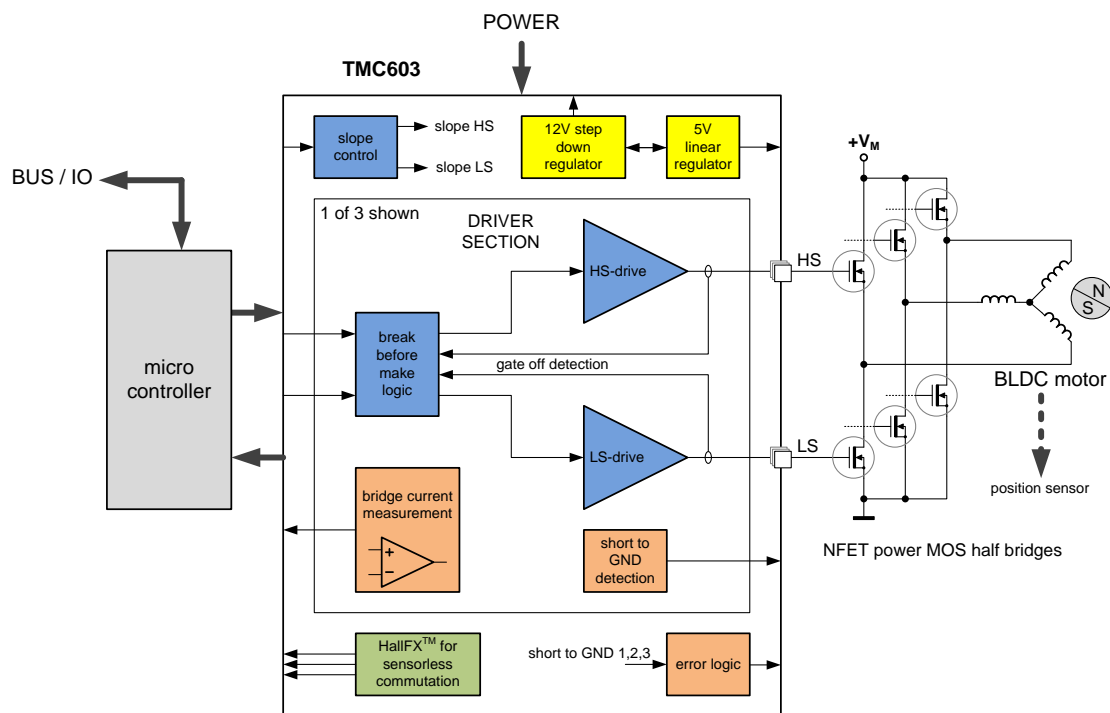

figure 1: application block diagram

The TMC603 is a BLDC driver IC using external power MOS transistors. Its unique feature set allows equipping inexpensive and small drive systems with a maximum of intelligence, protection and diagnostic features. Control algorithms previously only found in much more complex servo drives can now be realized with a minimum of external components. Depending on the desired commutation scheme and the bus interface requirements, the TMC603 forms a complete motor driver system in combination with an external 8 bit processor or with a more powerful 32 bit processor. A simple system can work with three standard PWM outputs even for sine commutation! The complete analog amplification and filtering frontend as well as the power driver controller are realized in the TMC603. Its integrated support for sine commutation as well as for back EMF sensing saves cost and allows for maximum drive efficiency.

The external microcontroller realizes commutation and control algorithms. Based on the position information from an encoder or hall sensors, the microcontroller can do block commutation or sine commutation with or without space vector modulation and realizes control algorithms like a PID regulator for velocity or position or field oriented control based on the current signals from the TMC603. For sensorless commutation, the microcontroller needs to do a forward controlled motor start without feedback. This can be realized either using block commutation or sine commutation. A sine commutated start-up minimizes motor vibrations during start up. As soon as the minimum velocity for hallFX is reached, it can switch to block commutation and drive the motor based on the hallFX signals.

The TMC603 also supports control of three phase stepper motors as well as two phase stepper motors using two devices.

4 Pinout

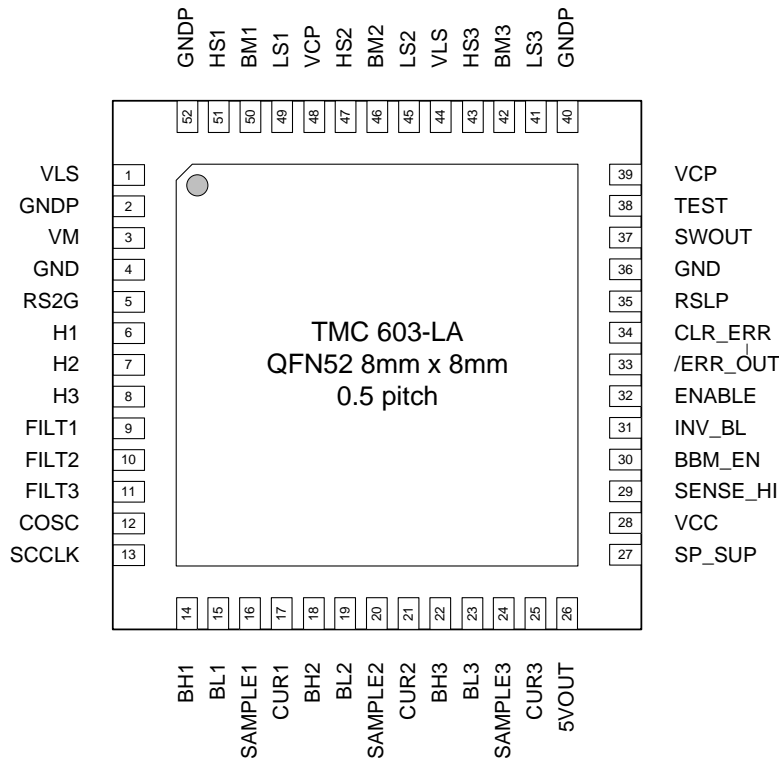

figure 2: pinning / QFN52 package (top view)

4.1 Package codes

Type	Package	Temperature range	Code/markings
TMC603	QFN52 (ROHS)	-40°C ... +125°C	TMC603-LA

4.2 Package dimensions QFN52

REF	MIN	NOM	MAX
A	0.80	0.85	0.90
A1	0.00	0.035	0.05
A2	-	0.65	0.67
A3		0.203	
b	0.2	0.25	0.3
D		8.0	
E		8.0	
e		0.5	
J	6.1	6.2	6.3
K	6.1	6.2	6.3
L	0.35	0.4	0.45

All dimensions are in mm.
Attention: Drawing not to scale.

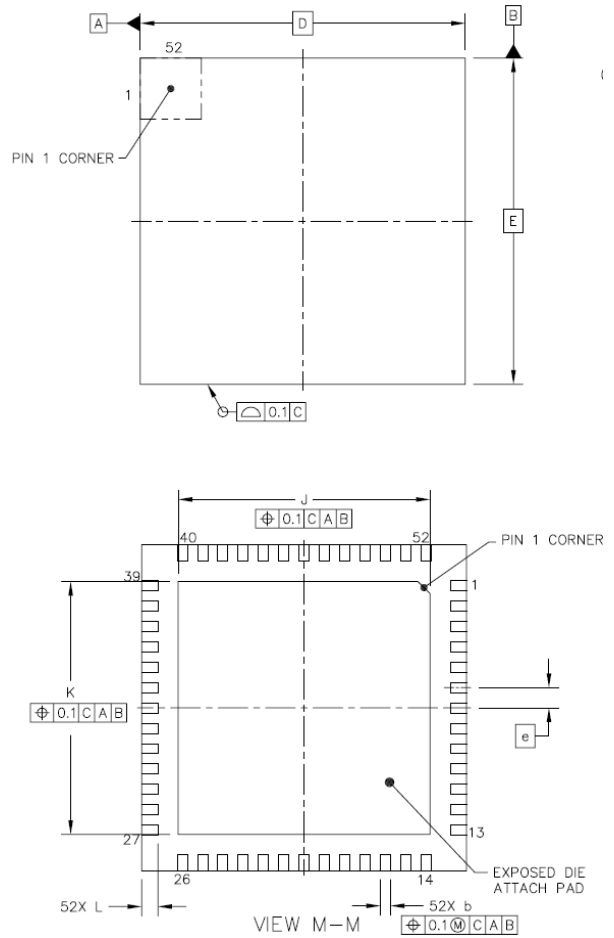
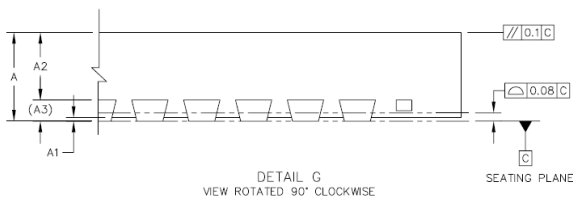

5 TMC603 functional blocks

5.1 Block diagram and pin description

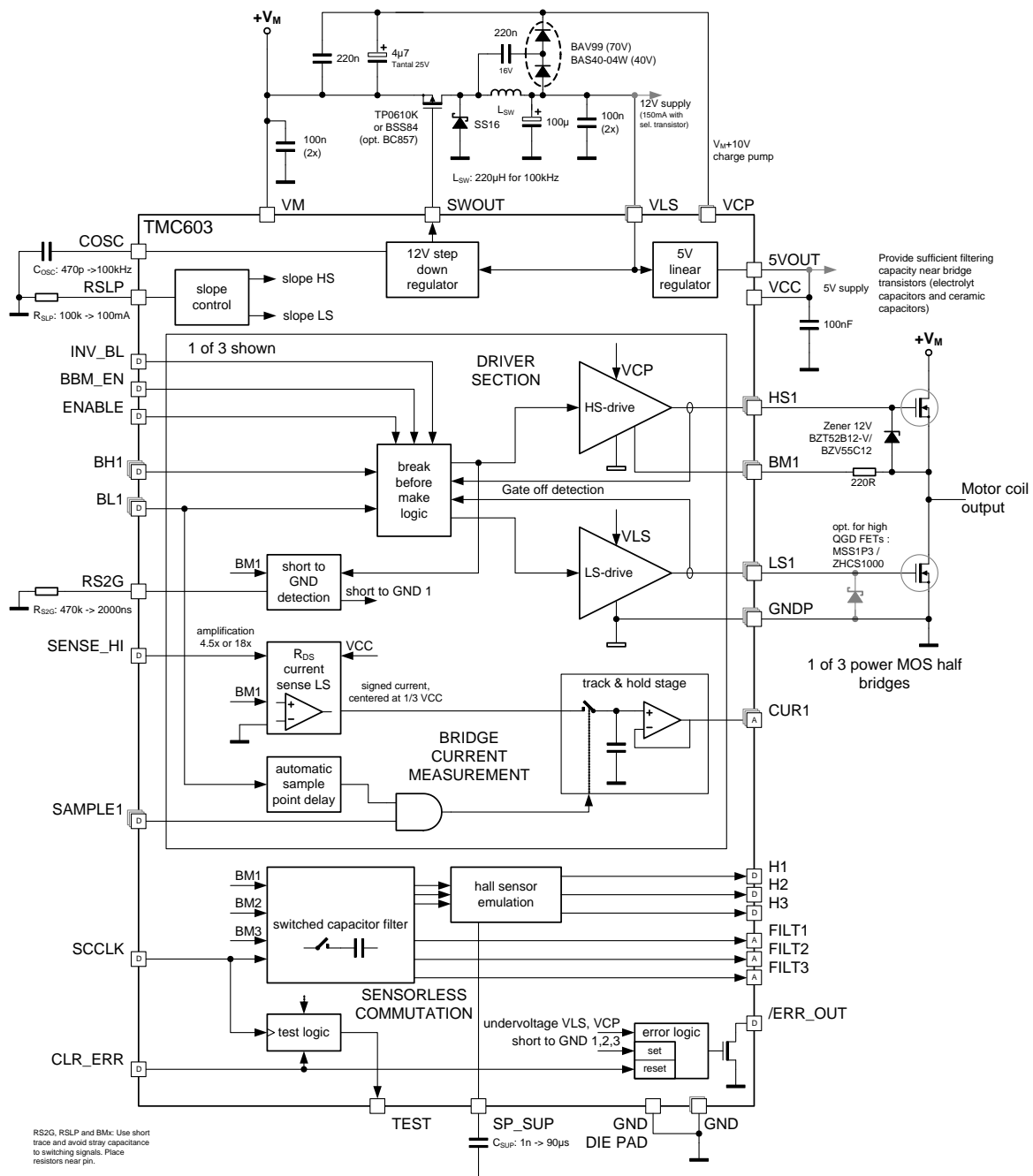

figure 3: application diagram

The application diagram shows the basic building blocks of the IC and the connections to the power bridge transistors, as well as the power supply. The connection of the digital and analog I/O lines to the microcontroller is highly specific to the microcontroller model used.

Pin	Number	Type	Function
VLS	1, 44		Low side driver supply voltage for driving low side gates
GNDP	2, 40, 52		Power GND for MOSFET drivers, connect directly to GND
VM	3		Motor and MOSFET bridge supply voltage
GND	4, 36		Digital and analog low power GND
RS2G	5	AI 5V	Short to GND control resistor. Controls delay time for short to GND test
Hx	6, 7, 8	DO 5V	hallFX outputs for back EMF based hall sensor emulation
FILT _x	9, 10, 11	AO 5V	Output of internal switched capacitor filter
COSC	12	A 5V	Oscillator capacitor for step down regulator
SCCLK	13	DI 5V	Switched capacitor filter clock input for hallFX filters.
BH _x	14, 18, 22	DI 5V	High side driver control signal: A positive level switches on the high side
BL _x	15, 19, 23	DI 5V	Low side driver control signal: Polarity can be reversed via INV_BL
SAMPLE _x	16, 20, 24	DI 5V	Optional external control for current measurement sample/hold stage. Set to positive level, if unused
CUR _x	17, 21, 25	AO 5V	Output of current measurement amplifier
5VOUT	26		Output of internal 5V linear regulator. Provided for VCC supply
SP_SUP	27	A 5V	An external capacitor on this pin controls the commutation spike suppression time for hallFX.
VCC	28		+5V supply input for digital I/Os and analog circuitry
SENSE_HI	29	DI 5V	Switches current amplifiers to high sensitivity
BBM_EN	30	DI 5V	Enables internal break-before-make circuitry
INV_BL	31	DI 5V	Allows inversion of BL _x input active level (low: BL _x is active high)
ENABLE	32	DI 5V	Enables the power drivers (low: all MOSFETs become actively switched off)
/ERR_OUT	33	DO 5V	Error output (open drain). Signals undervoltage or overcurrent. Tie to ENABLE for direct self protection of the driver
CLR_ERR	34	DI 5V	Reset of error flip-flop (active high). Clears error condition
RSLP	35	AI 5V	Slope control resistor. Sets output current for MOSFET drivers
SWOUT	37	O	Switch regulator transistor output
TEST	38	O 12V	Test multiplexer output (leave open)
VCP	39		Charge pump supply voltage. Provides high side driver supply
LS _x	41, 45, 49	O 12V	Low side MOSFET driver output
BM _x	42, 46, 50	I (VM)	Sensing input for bridge outputs. Used for MOSFET control and current measurement.
HS _x	43, 47, 51	O (VCP)	High side MOSFET driver output
Exposed die pad	-	GND	Connect the exposed die pad to a GND plane. It is used for cooling of the IC and may either be left open or be connected to GND.

5.2 MOSFET Driver Stage

The TMC603 provides three half bridge drivers, each capable of driving two MOSFET transistors, one for the high-side and one for the low-side. In order to provide a low R_{DSon} , the MOSFET gate driving voltage is about 10V to 12V.

The TMC603 bridge drivers provide a number of unique features for simple operation, explained in the following chapters:

- An integrated automatic break-before-make logic safely switches off one transistor before its counterpart can be switched on.
- Slope controlled operation allows adaptation of the driver strength to the desired slope and to the chosen transistors.
- The drivers protect the bridge actively against cross conduction (Q_{GD} protection)
- The bridge is protected against a short to GND

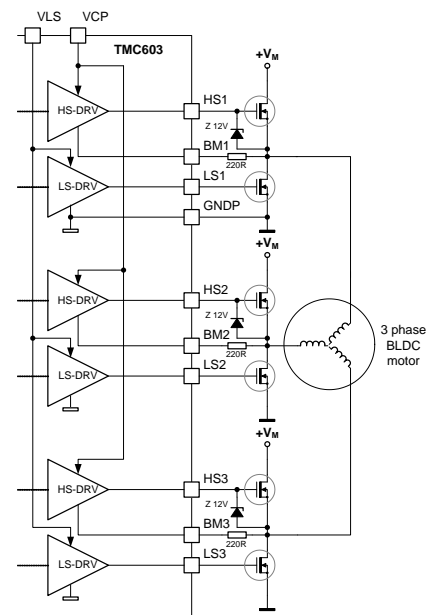

figure 4: three phase BLDC driver

5.2.1 Principle of operation

The low side gate driver voltage is supplied by the VLS pins. The low side driver supplies 0V to the MOSFET gate to close the MOSFET, and VLS to open it.

The TMC603 uses a patented driver principle for driving of the high side:

The high-side MOSFET gate voltage is referenced to its source at the center of the half bridge. Due to this, the TMC603 references the gate drive to the bridge center (BM) and has to be able to drive it to a voltage lying above the positive bridge power supply voltage V_M . This is realized by a charge pump voltage generated from the switching regulator via a Villard circuit. When closing the high-side MOSFET, the high-side driver drives it down to the actual BM potential, since an external induction current from the motor coil could force the output to stay at high potential. This is accomplished by a feedback loop and transistor TG1 (see figure). In order to avoid floating of the output BM, a low current is still fed into the HS output via transistor TG1a. The input BM helps the high side driver to track the bridge voltage. Since input pins of the TMC603 must not go below -0.7V, the input BM needs to be protected by an external resistor. The resistor limits the current into BM to a level, the ESD protection input diodes can accept.

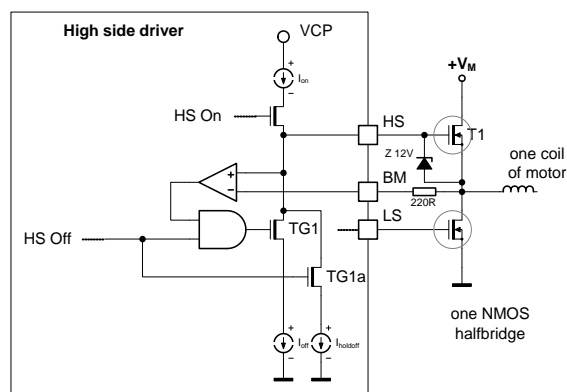

figure 5: principle of high-side driver (pat.fil.)

A zener diode at the gate (range 12V to 15V) protects the high-side MOSFET in case of a short to GND event: Should the bridge be shorted, the gate driver output is forced to stay at a maximum of the zener voltage above the source of the transistor. Further it prevents the gate voltage from dropping below source level.

The maximum permissible MOSFET driver current depends on the motor supply voltage:

Parameter	Symbol	Max	Unit
MOSFET driver current with $V_{VM} < 30V$	I_{HSX}, I_{LSX}	150	mA
MOSFET driver current with $30V < V_{VM} < 50V$		$150 - 2.5 * (V_{VM} - 30V)$	mA
MOSFET driver current with $V_{VM} = 50V$	I_{HSX}, I_{LSX}	100	mA

Pin	Comments
LSx	Low side MOSFET driver output. The driver current is set by resistor R_{SLP}
HSx	High side MOSFET driver output. The driver current is set by resistor R_{SLP}
BMx	Bridge center used for current sensing and for control of the high side driver. For unused bridges, connect BMx pin to GND and leave the driver outputs unconnected. Place the external protection resistor near the IC pin.
RSLP	The resistor connected to this pin controls the MOSFET gate driver current. A 40 μ A current out of this pin (resistor value of 100k Ω to GND) results in the nominal maximum current at full supply range. Keep interconnection between IC and resistor short, to avoid stray capacitance to adjacent signal traces of modulating the set current. Resistor range: 60 k Ω to 500 k Ω
VLS	Low side driver supply voltage for driving low side gates
VCP	Charge pump supply voltage. Provides high side driver supply
GNDP	Power GND for MOSFET drivers, connect directly to GND
BHx	High side driver control signal: A positive level switches on the high side. For unused bridges, tie to GND.
BLx	Low side driver control signal: Polarity can be reversed via INV_BL
INV_BL	Allows inversion of BLx input active level (low: BLx is active high). When high, each BLx and BHx can be connected in parallel in order to use only 3 PWM outputs for bridge control. Be sure to switch on internal break-before-make logic (BBM_EN = Vcc) to avoid bridge short circuits in this case.

5.2.2 Break-before-make logic

Each half-bridge has to be protected against cross conduction during switching events. When switching off the low-side MOSFET, its gate first needs to be discharged, before the high side MOSFET is allowed to be switched on. The same goes when switching off the high-side MOSFET and switching on the low-side MOSFET. The time for charging and discharging of the MOSFET gates depends on the MOSFET gate charge and the driver current set by R_{SLP} . When the BBM logic is enabled, the TMC603 measures the gate voltage and automatically delays switching on of the opposite bridge transistor, until its counterpart is discharged. The BBM logic also prevents unintentional bridge short circuits, in case both, LSx and HSx, become switched on. The first active signal has priority.

Alternatively, the required time can be calculated and pre-compensated in the PWM block of the microcontroller driving the TMC603 (external BBM control).

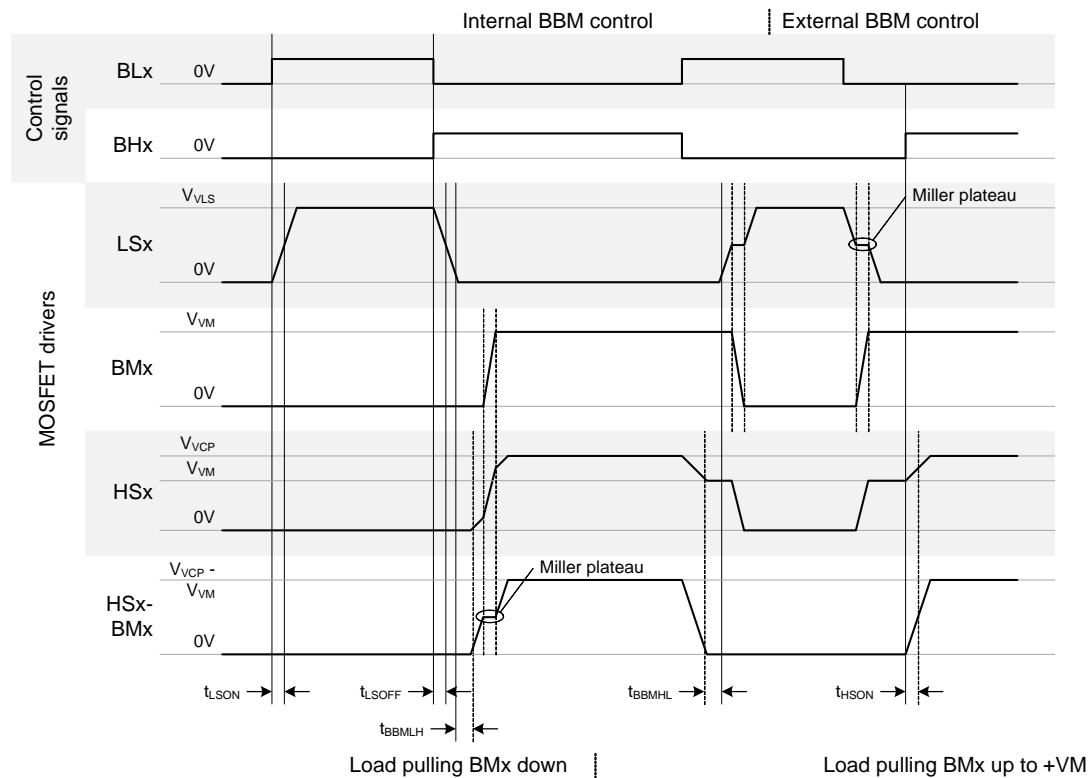

figure 6: bridge driver timing

Pin	Comments
BBM_EN	Enables internal break-before-make circuitry (high = enable)

5.2.3 PWM control via microcontroller

There is a number of different microcontrollers available, which provide specific BLDC commutation units. However, the TMC603 is designed in a way in order to allow BLDC control via standard microcontrollers, which have only a limited number of (free) PWM units. The following figure shows several possibilities to control the BLDC motor with different types of microcontrollers, and shall help to optimally adapt the TMC603 control interface to the features of your microcontroller. The hall signals and further signals, like CURx interconnection to an ADC input, are not shown.

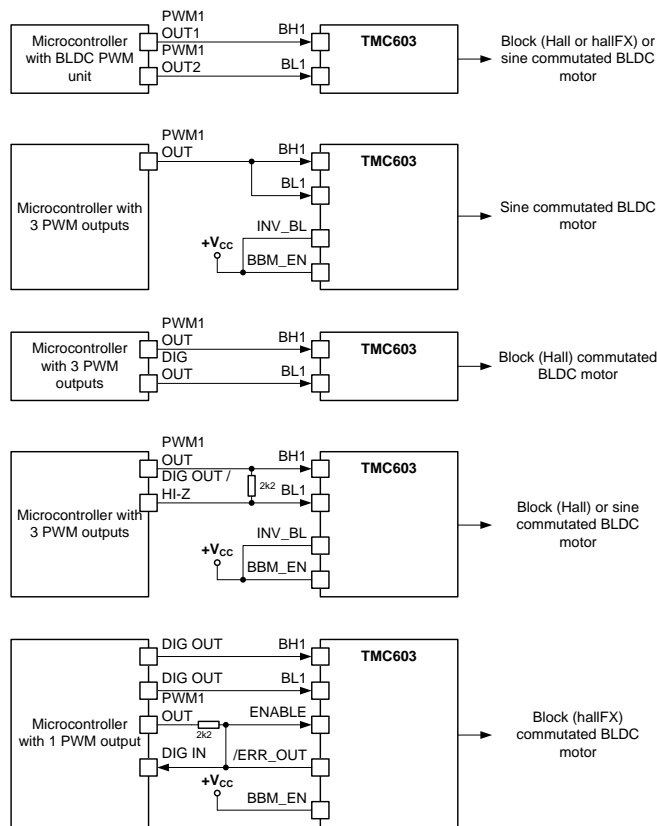

figure 7: examples for microcontroller PWM control

5.2.4 Slope control

The TMC603 driver stage provides a constant current output stage slope control. This allows to adapt driver strength to the drive requirements of the power MOSFET and to adjust the output slope by providing for a controlled gate charge and discharge. A slower slope causes less electromagnetic emission, but at the same time power dissipation of the power transistors rises. The duration of the complete switching event depends on the total gate charge. The voltage transition of the output takes place during the so called miller plateau (see figure 6). The miller plateau results from the gate to drain capacity of the MOSFET charging / discharging during the switching. From the datasheet of the transistor (see example in figure 8) it can be seen, that the miller plateau typically covers only a part (e.g. one quarter) of the complete charging event. The gate voltage level, where the miller plateau starts, depends on the gate threshold voltage of the transistor and on the actual load current.

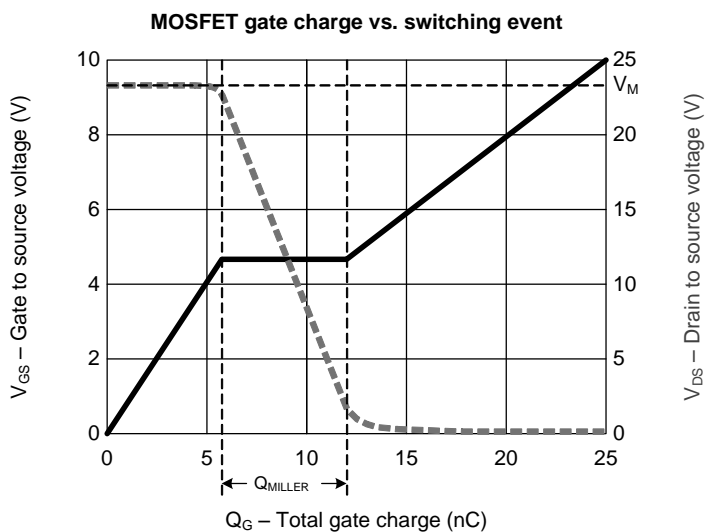

figure 8: MOSFET gate charge as available in device data sheet vs. switching event

The slope time t_{SLOPE} can be calculated as follows:

$$t_{SLOPE} = \frac{Q_{MILLER}}{I_{GATE}}$$

Whereas Q_{MILLER} is the charge the power transistor needs for the switching event, and I_{GATE} is the driver current setting of the TMC603.

Taking into account, that a slow switching event means high power dissipation during switching, and, on the other side a fast switching event can cause EMV problems, the desired slope will be in some ratio to the switching (chopper) frequency of the system. The chopper frequency is typically slightly outside the audible range, i.e. 18 kHz to 40 kHz. The lower limit for the slope is dictated by the reverse recovery time of the MOSFET internal diodes, unless additional Schottky diodes are used in parallel to the MOSFETs source-drain diode. Thus, for most applications a switching time between 100ns and 750ns is chosen.

The required slope control resistor R_{SLP} can be calculated as follows:

$$I_{GATE} = \frac{4V}{R_{SLP}} * \frac{100mA}{40\mu A} \leftrightarrow$$

$$R_{SLP} = \frac{10A * t_{SLOPE}}{Q_{MILLER}} k\Omega$$

Example:

A circuit using the transistor from the diagram above shall be designed for a slope time of 200ns. The miller charge of the transistor is about 6nC.

$$R_{SLP} = \frac{10A * 200ns}{6nC} k\Omega = 333k\Omega$$

The nearest available resistor value is 330 kΩ. It sets the gate driver current to roughly 30 mA. This is well within the minimum and maximum R_{SLP} resistor limits.

5.2.5 Reverse capacity (QGD) protection

The principle of slope control often is realized by gate series resistors with competitor's products, but, as latest MOSFET generations have a fairly high gate-drain charge (Q_{GD}), this approach is critical for safe bridge operation. If the gate is not held in the off state with a low resistance, a sudden raise of the voltage at the drain (e.g. when switching on the complementary transistor) could cause the gate to be pulled high via the MOSFETs gate drain capacitance. This would switch on the transistor and lead to a bridge short circuit.

The TMC603 provides for safe and reliable slope controlled operation by switching on a low resistance gate protection transistor (see figure).

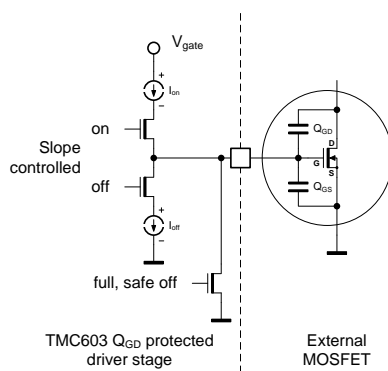

figure 9: QGD protected driver stage

5.2.6 Considerations for QGD protection

This chapter gives the background understanding to ensure a safe operation for MOSFETs with a gate-drain (Miller) charge Q_{GD} substantially larger than the gate-source charge Q_{GS} .

In order to guarantee a safe operation of the Q_{GD} protection, it is important to spend a few thoughts on the slope control setting. Please check your transistors' data sheet for the gate-source charge Q_{GS} and the gate-drain charge Q_{GD} (Miller charge). In order to turn on the MOSFET, first the gate-source charge needs to be charged to the transistor's gate. Now, the transistor conducts and switching starts. During the switching event, the additional Q_{GD} needs to be charged to the gate in order to complete the switching event. Wherever Q_{GD} is larger than Q_{GS} , a switching event of the complementary MOSFET may force the gate of the switched off MOSFET to a voltage above the gate threshold voltage. For these MOSFETs the Q_{GD} protection ensures a reliable operation, as long as the slopes are not set too fast.

Calculating the maximum slope setting for high Q_{GD} MOSFETs:

Taking into account effects of the MOSFET bulk diode (compare chapter 5.2.7), the maximum slope of a MOSFET bridge will be around the double slope as calculated from the Miller charge and the gate current. Based on this, we can estimate the current required to hold the MOSFET safely switched off:

During the bridge switching period, the driver must be able to discharge the difference of Q_{GD} and Q_{GS} while maintaining a gate voltage below the threshold voltage.

Therefore

$$I_{OFFQGD} * \frac{t_{SLOPE}}{2} > Q_{GD} - Q_{GS} \rightarrow$$

$$I_{OFFQGD} * \frac{Q_{GD}}{I_{ON}} > Q_{GD} - Q_{GS}$$

Thus the minimum value required for I_{OFFQGD} can be calculated:

$$I_{OFFQGD} = I_{ON} * \frac{Q_{GD} - Q_{GS}}{Q_{GD}} * 2$$

Where I_{ON} is the gate current set via R_{SLP} , and I_{OFFQGD} is the Q_{GD} protection gate current.

The low side driver has a lower Q_{GD} protection current capability than the high side driver, thus we need to check the low side. With its $R_{LSOFFQGD}$ of roughly 15 Ohm, the TMC603 can keep the gate voltage to a level of:

$$U_{GOFF} = I_{OFF} * R_{LSOFFQGD}$$

Now we just need to check U_{GOFF} against the MOSFETs output characteristics, to make sure, that no significant amount of drain current can flow.

Example:

A MOSFET, where Q_{GD} is 3 times larger than Q_{GS} is driven with 100mA gate current.

$$I_{OFF} = 100mA * \frac{3Q_{GS} - Q_{GS}}{3Q_{GS}} * 2 = 133mA$$

The TMC603 thus can keep the gate voltage level to a maximum voltage of

$$U_{GOFF} = 133mA * 15\Omega = 2V$$

This is sufficient to keep the MOSFET safely off.

Note:

Do *not* add gate series resistors to your MOSFETs! This would eliminate the effect of the Q_{GD} protection. Gate series resistors of a few Ohms only may make sense, when paralleling multiple MOSFETs in order to avoid parasitic oscillations due to interconnection inductivities.

5.2.7 Effects of the MOSFET bulk diode

Whenever inductive loads are driven, the inductivity will try to sustain current when current becomes switched off. During bridge switching events, it is important to ensure break-before-make operation, e.g. one MOSFET becomes switches off, before the opposite MOSFET is switched on. Depending on the actual direction of the current, this results in a short moment of a few 100 nanoseconds, where the current flowing through the inductive load forces the bridge output below the lower supply rail or above the upper supply rail. The respective MOSFET bulk diode in this case takes over the current. The diode saturates at about -1.2V. But the bulk diode is not an optimum device. It typically has reverse recovery time of a few ten to several 100ns and a reverse recovery charge in the range of some 100nC or more. Assuming, that the bulk diode of the switching off MOSFET takes over the current, the complementary MOSFET sees the sum of the coil current and the instantaneous current needed to recover the bulk diode when trying to switch on. The reverse recovery current may even be higher than the coil current itself! As a result, a number of very quick oscillations on the output appear, whenever the bulk diode leaves the reverse recovery area, because up to the half load current becomes switched off in a short moment. The effect becomes visible as an oscillation due to the parasitic inductivities of the PCB traces and interconnections. While this is normal, it adds high current spikes, some amount of dynamic power dissipation and high frequency electromagnetic emission. Due to its high frequency, the ringing of this current can also be seen on the gate drives and thus can be easily mistaken as a gate driving problem.

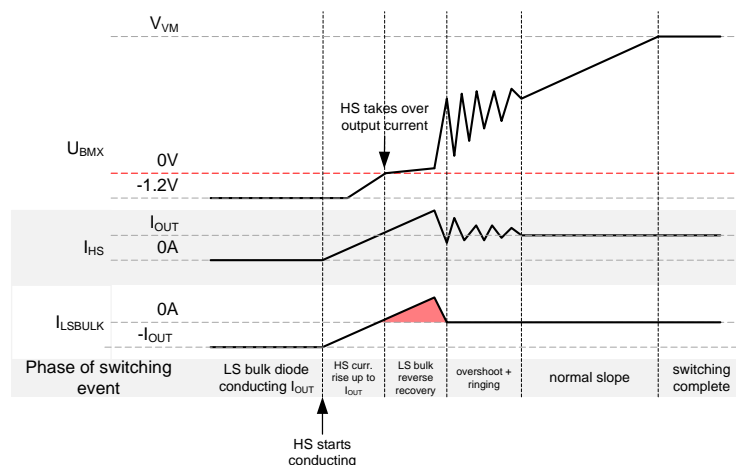

figure 10: effect of bulk diode recovery

A further conclusion from this discussion: Do *not* set the bridge slope time higher than or near to the reverse recovery time of the MOSFETs, as the parasitic current spikes will multiply the instantaneous current across the bridge. A plausible time is a factor of three or more for the slope time. If this cannot be tolerated please see the discussion on adding Schottky diodes.

5.2.8 Adding Schottky diodes across the MOSFET bulk diodes

In order to avoid effects of bulk diode reverse recovery, choose a fast recovery switching MOSFET. The MOSFET transistors can also be bridged by a Schottky diode, which has a substantially faster reverse recovery time. This Schottky diode needs to be chosen in a way that it can take over the full bridge current for a short moment of time only. During this time, the forward voltage needs to be lower than the MOSFETs forward voltage. A small 5A diode like the SK56 can take over a current of 20A at a forward voltage of roughly 0.8V.

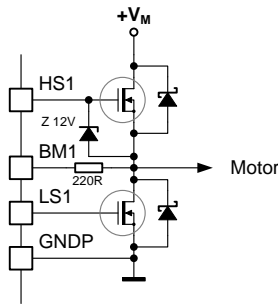

figure 11: parallel Schottky diode avoids current spikes due to bulk diode recovery

5.2.9 Short to GND detection

An overload condition of the high side MOSFET (“short to GND”) is detected by the TMC603, by monitoring the BM voltage during high side on time. Under normal conditions, the high side power MOSFET reaches the bridge supply voltage minus a small voltage drop during on time. If the bridge is overloaded, the voltage cannot rise to the detection level within a limited time, defined by an external resistor. Upon detection of an error, the error output is activated. By directly tying it to the enable input, the chip becomes disabled upon detection of a short condition and the error flip flop becomes set.

A variation of the short to GND detection delay allows adaptation to the slope control, and modification of the sensitivity of the detection during power up.

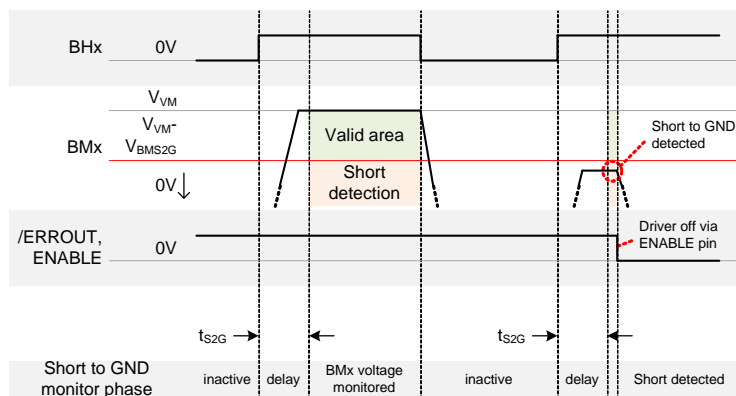

figure 12: timing of the short to GND detector

Pin	Comments
RS2G	<p>The resistor connected to this pin controls the delay between switching on the high side MOSFET and the short to GND check. A 20 μA current out of this pin (resistor value of 220 $\text{k}\Omega$ to GND) results in a 500 ns delay, a lower current gives a longer delay. Disconnecting the pin disables the function. Keep interconnection between IC and resistor short, to avoid stray capacitance to adjacent signal traces of modulating the set current.</p> <p>Resistor range: 47 $\text{k}\Omega$ to 1 $\text{M}\Omega$</p>

5.2.10 Error logic

The TMC603 has three different sources for signaling an error:

- Undervoltage of the low side supply
- Undervoltage of the charge pump
- Short to GND detector

Upon any of these events the error output is pulled low. After a short to GND detector event, the error output remains active, until it becomes cleared by the CLR_ERR. By tying the error output to the enable input, the TMC603 automatically switches off the bridges upon an error. The enable input then should be driven via an open collector input plus pull-up resistor, or via a resistor.

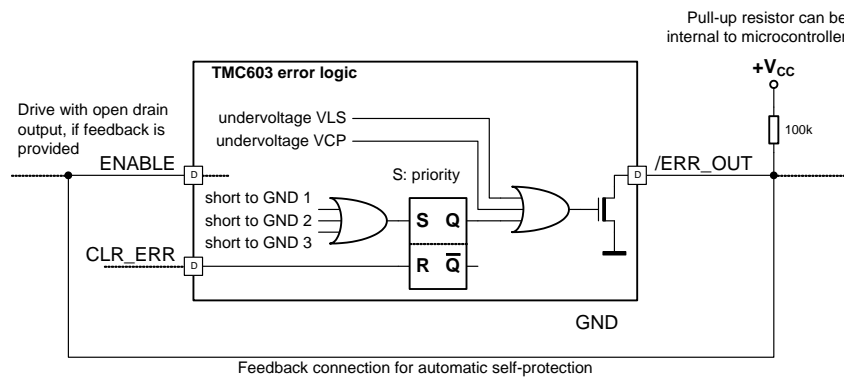

figure 13: error logic

Pin	Comments
/ERR_OUT	Error output (open drain). Signals undervoltage or overcurrent. Tie to ENABLE for direct self protection of the driver. The internal error condition generator has a higher priority than the CLR_ERR input, i.e. the error condition can not be cleared, as long as it is persistent.
CLR_ERR	Reset of error flip-flop (active high). Clears error condition. The error condition should at least be cleared once after IC power on.
ENABLE	Enables the power drivers (low: all MOSFETs become actively switched off)

5.3 Current measurement amplifiers

The TMC603 amplifies the voltage drop in the three lower MOSFET transistors in order to allow current measurement without the requirement for current sense (shunt) resistors. This saves cost and board space, as well as the additional power dissipation in the shunt resistors. However, additional shunt resistors can be added, e.g. source resistors for each lower MOSFET or a common shunt resistor in the bridge foot point, in order to increase voltage drop and to have a more exact measurement.

The TMC603 CURx outputs deliver a signal centered to 1/3 of the 5V VCC supply. This allows measurement of both, negative and positive signals, while staying compatible to a 3.3V microcontroller. The current amplifier is an inverting type.

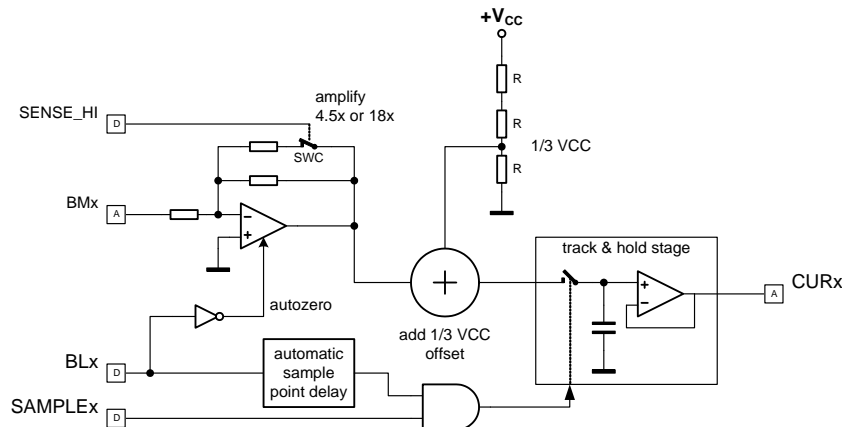

figure 14: schematic of current measurement amplifiers

Pin	Comments
CURx	Output of current measurement amplifier. The output signal is centered to 1/3 VCC.
SENSE_HI	Switches current amplifiers to high sensitivity (high level). Control by processor to get best sensitivity and resolution for measurement.
SAMPLEx	Optional external control for current measurement sample/hold stage. Set to positive level, if unused

The voltage drop over the MOSFET is calculated as follows:

$$V_{MOSFET} = \frac{x_0 - x}{ADC_{MAX}} * V_{ADCREf} / A_{CUR}$$

whereas x is the ADC output value, x_0 is the ADC output value at zero current (e.g. 85 for an 8 bit ADC with 5V reference voltage), ADC_{MAX} is the range of the ADC (e.g. 256 for an 8 bit ADC), V_{ADCREf} is the reference voltage of the ADC and A_{CUR} is the currently selected amplification (absolute value) of the TMC603.

With this, the motor current can be calculated using the on resistance $R_{DS(ON)}$ (at 10V) of the MOSFET:

$$I_{MOSFET} = \frac{V_{MOSFET}}{R_{DS(ON)}}$$

5.3.1 Current measurement timing

Current measurement is self-timed, in order to only provide valid output voltages. Sampling is active during the low side ON time. The sampling is delayed by an internal time delay, in order to avoid sampling of instable values during settling time of the bridge current and amplifiers. Thus, a minimum ON time is required in order to get a current measurement. The output CURx reflects the current during the measurement. The last value is held in a track and hold circuit as soon as the low side transistor switches off.

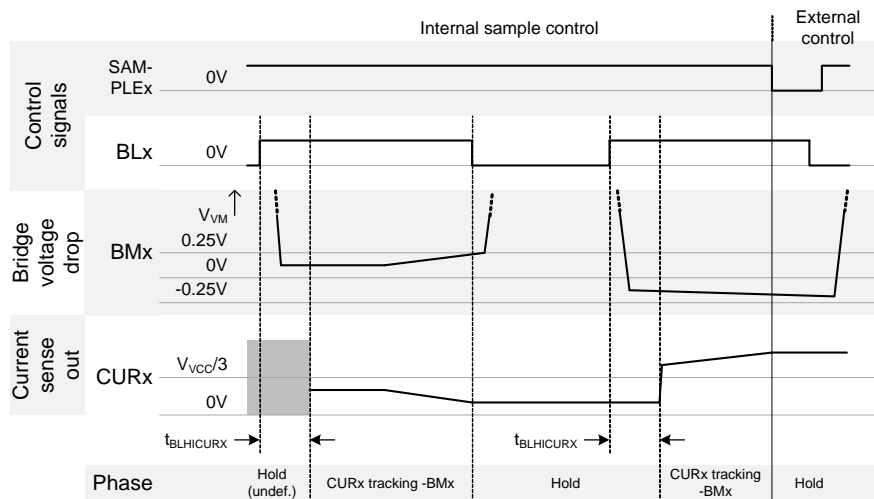

figure 15: timing of the current measurement

The SAMPLEx pins will normally be unused and can be tied to VCC. For advanced applications, where a precise setting of the current sampling point is desired, e.g. centered to the on-time, SAMPLEx pins can be deactivated at the desired point of time, enabling the hold stage.

5.3.2 Auto zero cycle

The current measurement amplifiers do an automatic zero cycle during the OFF time of the low side MOSFETs. The zero offset is stored in internal capacitors. This requires switching off the low side at least once, before the first measurement is possible, and on a cyclic basis, to avoid drifting away of the zero reference. This normally is satisfied by the chopper cycle. If commutation becomes stopped, e.g. due to motor stand still, the respective phase current measurement could drift away. After the first switching off and on of the low side, the measurement becomes valid again.

5.3.3 Measurement depending on chopper cycle

If the low side on-time on one phase $t_{BLHICURX}$ is too low, a current measurement is not possible. The TMC603 automatically does not sample the current if the minimum low side-on time is not met. This condition can arise in normal operation, e.g. due to the commutation angle defined by a sine commutation chopper scheme. The respective CURx output then does not reflect the phase current. Thus, the CURx output of a phase should be ignored, if the on-time falls below the minimum low side on-time for current measurement (please refer to maximum limit). The correct current value can easily be calculated from the difference of the remaining two current measurements.

5.3.4 Compensating for offset voltages

In order to measure low current values precisely, the "zero" value (x_0) of $1/3 V_{CC}$ can be measured via the ADC, rather than being hard coded into the measurement software. This is possible by doing a first current measurement during motor stand-still, with no current flowing in the motor coils, e.g. during a test phase of the unit. The resulting value can be stored and used as zero reference. However, the influence of offset voltages can be minimized, by using the high sensitivity setting of the amplifiers for low currents, and switching to low sensitivity for higher currents.

5.3.5 Getting a precise current value

The ON-resistance of a MOSFET has a temperature co-efficient, which should not be ignored. Thus, the temperature of the MOSFETs must be measured, e.g. using an NTC resistor, in order to compensate for the variation. Also, the initial R_{DSon} depends upon fabrication tolerance of the MOSFETs. If exact measurement is desired, an adjustment should be done during initial testing of each product. For applications, where an adjustment is not possible, the use of at least one additional shunt resistor in the common ground line of all three half bridges provides a stable current measurement base, which allows in-system adjustment of the relative MOSFET resistances. Further, the TMC603 measurement amplification is slightly different for positive and negative currents.

5.4 hallFX sensorless commutation

hallFX provides emulated hall sensor signals. The emulated hall sensor signals are available without a phase shift and there is no error-prone PLL necessary, like with many other systems, nor is the knowledge of special motor parameters required. Since it is based on the motors' back-EMF, a minimum motor velocity is required to get a valid signal. Therefore, the motor needs to be started without feedback, until the velocity is high enough to generate a reliable hallFX signal.

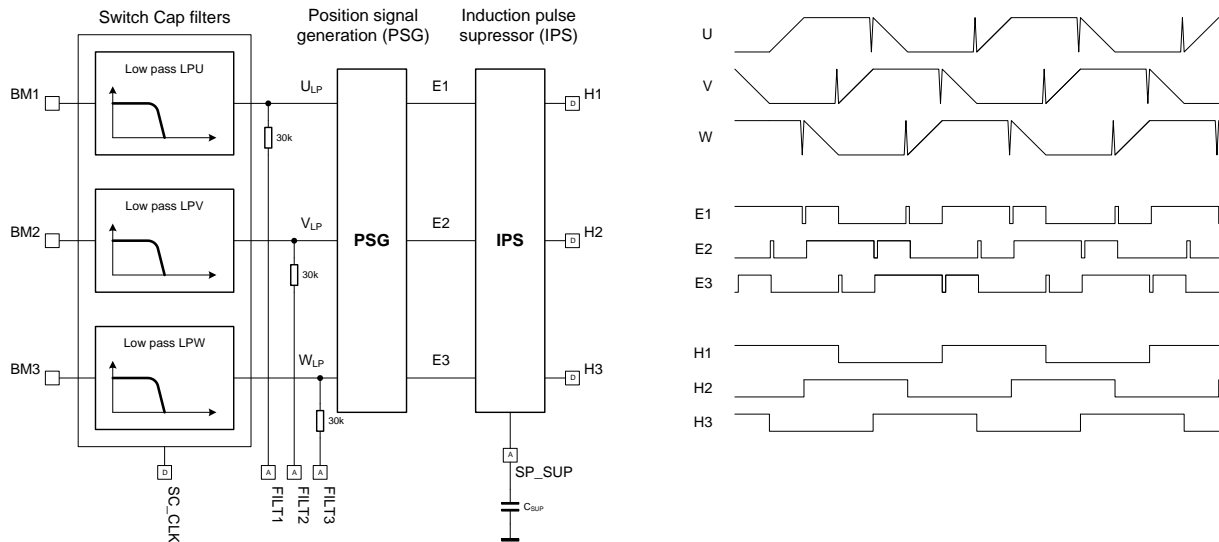

figure 16: hallFX block diagram and timing

A switched capacitor filter for each coil supplies the measured effective coil voltages. Its filter frequency can be adapted to the chopper frequency and the desired maximum motor velocity. An induction pulse suppressor unit gates the commutation spikes which result from the inductive behavior of the motor coils after switching off the current. The gating time can be adapted by an external capacitor to fit the motor inductivity and its (maximum) velocity.

Pin	Comments
SP_SUP	A capacitor attached to this pin sets the spike suppression time. This pin charges the capacitor via an internal current source. If more exact timing is required, an external 47k pull-up resistor to VCC can be used in parallel to the internal current source. The capacitor becomes discharged upon each valid commutation. The capacitor can optionally be left away, and the suppression can be done in software.
FILT _x	These pins provide the filtered coil voltages. For most applications this will be of no use, except when an external back-EMF commutation is realized, e.g. using a microcontroller with ADC inputs. Because of the high output resistance and low current capability of these pins, it is advised to add an external capacitor of a few hundred picofarad up to a few nanofarad to GND, if the signals are to be used. This prevents noise caused by capacitance to adjacent signal traces to disturb the signal.
H _x	Emulated hall sensor output signal of hallFX block.
SCCLK	An external clock controls the corner frequency of the switched capacitor filter. A 1.25 MHz clock gives a filter bandwidth of 3kHz. A lower clock frequency may be better for lower motor velocities.

5.4.1 Adjusting the hallFX spike suppression time

hallFX needs two minimum motor- and application-specific adjustments: The switched capacitor clock frequency and the spike suppression time should be adapted. Both can easily be deduced from basic application parameters and are not very critical. The SCCLK frequency should be matched to the chopper frequency of the system and the maximum motor velocity. The spike suppression time needs to be adapted to the desired maximum motor velocity.

Calculating the commutation frequency f_{COM} of the motor:

$$f_{COM} = \frac{S_{RPM}}{60} * n_{POLE} * 3$$

S_{RPM} is the rotation velocity in RPM

n_{POLE} is the pole count of the actual motor, or the double of the number of pole pairs

The spike suppression time can be chosen as high, as the commutation frequency required for maximum motor velocity allows. As a thumb rule, we take half of this time to have enough spare.

$$t_{SPSUP} = 100\mu s * \frac{C_{SUP}}{1nF} \Rightarrow$$

$$C_{SUP} = \frac{1}{2} * \frac{1nF}{f_{COM} * 100\mu s} = \frac{100000}{S_{RPM} * n_{POLE}} nF$$

Example:

Given a 4 pole motor operating at 4000 RPM:

$C_{SUP} = 6.25nF$. The nearest value is 6.8nF.

5.4.2 Adjusting the hallFX filter frequency

The filter block needs to separate the motors' back EMF from the chopper pulses. Thus, the target is, to filter away as much commutation noise as possible, while maintaining as much of the back EMF signal as possible. Therefore, we need to find a cut-off frequency in between the chopper frequency and the electrical frequency of the motor. Since we do not want to change the frequency within the application, we use the nominal or maximum motor velocity to calculate its electrical frequency. The chopper frequency is given by the system, typically about 20 kHz.

The electrical frequency of the motor is:

$$f_{EL} = \frac{S_{RPM}}{60} * n_{POLE} / 2$$

Since the filter has a logarithmic behavior, as a thumb rule we can make a logarithmic mean-value as follows:

$$\log(f_{CUTOFF}) = \frac{\log(f_{EL}) + \log(f_{CHOP})}{2}$$

With the cut-off frequency being about 1/390 of the switched capacitor clock frequency f_{SCCLK} the following results as a thumb rule:

$$f_{SC_CLK} = 390 * 10^{\frac{\log(f_{EL}) + \log(f_{CHOP})}{2}}$$

The result shall be checked against minimum limit of 250 kHz and maximum limit of 4 MHz, however, the actual frequency is quite uncritical and can be varied in a wide range.

Example:

Given a 4 pole motor operating at 4000 RPM with a 20 kHz chopper frequency:

$f_{EL} = 133$ Hz

$f_{CUTOFF} = 1.6$ kHz

$f_{SCCLK} = 0.64$ MHz

The result is well within the limits, however, the frequency in a practical application can be chosen between 300 kHz and 1.5 MHz.

5.4.3 Block commutation chopper scheme for hallFX

hallFX works perfectly with nearly every motor. You can use a standard block commutation scheme, but the chopper must fulfill the following: The coils must be open for some percentage of the chopper period, in order to allow the back-EMF of the motor to influence the coil voltages. The motor direction

is determined by the start-up scheme, since the hallFX signals depend on the direction. Thus, the same commutation scheme is used for turn right and turn left! Only a single commutation table is required.

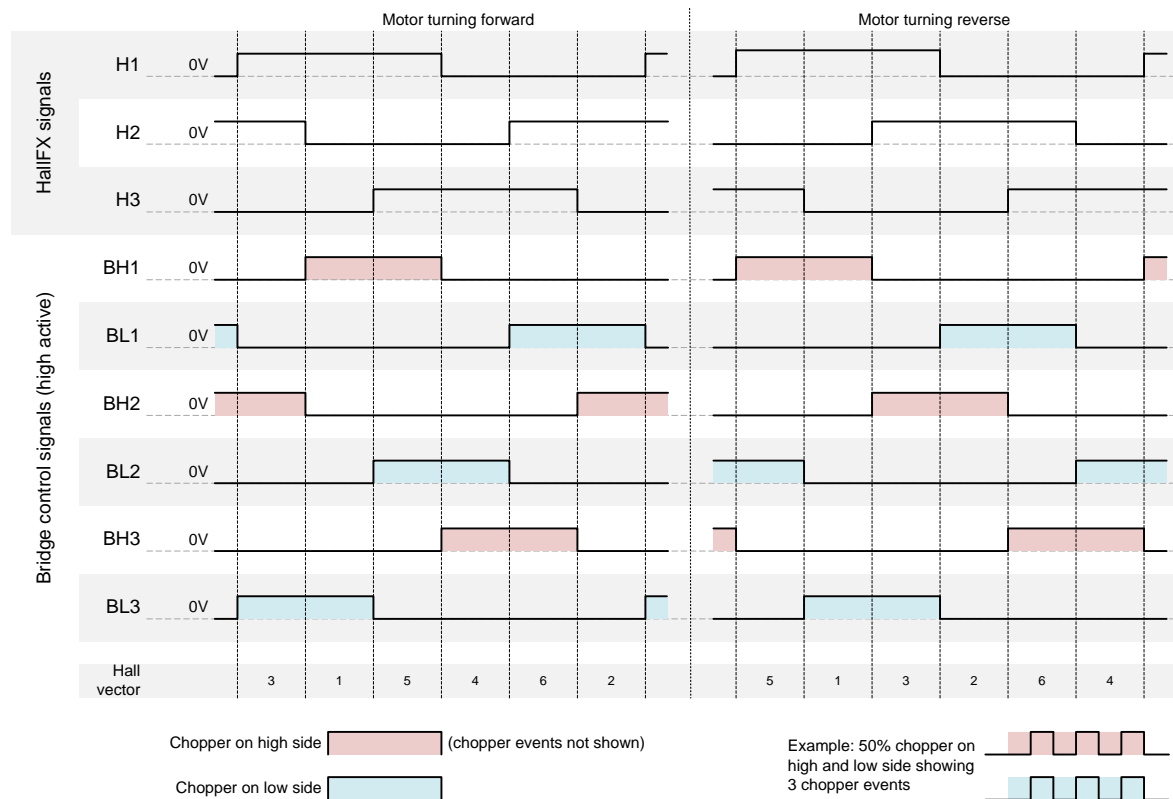

figure 17: hallFX based commutation

A chopper scheme fulfilling the desired coil open time per chopper period is shown here: Both, the high side driver and the low side driver are chopped with the same signal. The coil open time automatically is inverted to the duty cycle. In a practical application, the motor can run with a duty cycle of 15% to 25% (minimum motor velocity at low load) up to 90% to 95% (maximum motor velocity). The exact values depend on the actual motor. With a lower duty cycle the motor would not start, or back EMF would be too small to yield a valid hallFX signal. With a higher duty cycle, the back EMF would not be visible at the coil voltages, because the coils would be connected to GND or VM nearly the whole time. The minimum resulting coil open time thus is 5% to 10%. This simple chopper scheme automatically gives a longer measuring time at low velocities, when back EMF is lower. The actual borders for the commutation should be checked in the actual application. Provide enough headroom to compensate for variations due to motor load, mechanics and production stray.

5.4.4 Start-up sequence for the motor with forced commutation

In order to start the motor running with hallFX, it must reach a minimum velocity. The microcontroller needs to take care of this by starting the motor in a forward control mode, without feedback – just like a stepper motor. In order to allow a smooth transition to feedback mode, the same chopper scheme should be used as described above. Alternatively, the chopper scheme can be changed a few electrical periods before you switch to hallFX. This allows for example to start-up the motor using a sine commutation, to get a smooth movement also at low motor velocities. In a practical application, only a few percent up to 10% of the maximum motor velocity are sufficient for hallFX operation.

Turn the motor up to a minimum velocity, where you safely get correct hallFX signals. Since rotation of the motor can not be measured during this phase, the motor needs to be current controlled, with a current which in every case is high enough to turn the mechanical load. Current control can be done by feedback control, or by adapting the duty cycle to the motor characteristics. Further, the minimum starting speed and acceleration needs to be set matching the application. For sample code, please see www.trinamic.com. Upon reaching the threshold for hallFX operation, a valid hall signal becomes

available and allows checking success of the starting phase. The turning direction of the start-up sequence automatically determines the direction of motor operation with hallFX. You can check velocity and direction, as soon as valid hallFX signals are available.

When you experience commutation sequence errors during motor operation, probably motor velocity has dropped below the lower threshold. In this case, the motor could be restarted in forward control mode, or you could switch to forward control mode on the fly.

5.5 Power supply

The TMC603 integrates a +12V switching regulator for the gate driver supply and a +5V linear regulator for supply of the low voltage circuitry. The switching regulator is designed in a way, that it provides the charge pump voltage by using a Villard voltage doubler circuit. It is able to provide enough current to supply a number of digital circuits by adding an additional 3.3V or 5V low voltage linear or switching regulator. If a +5V microcontroller with low current requirement is used, the +5V regulator is sufficient, to also supply the microcontroller.

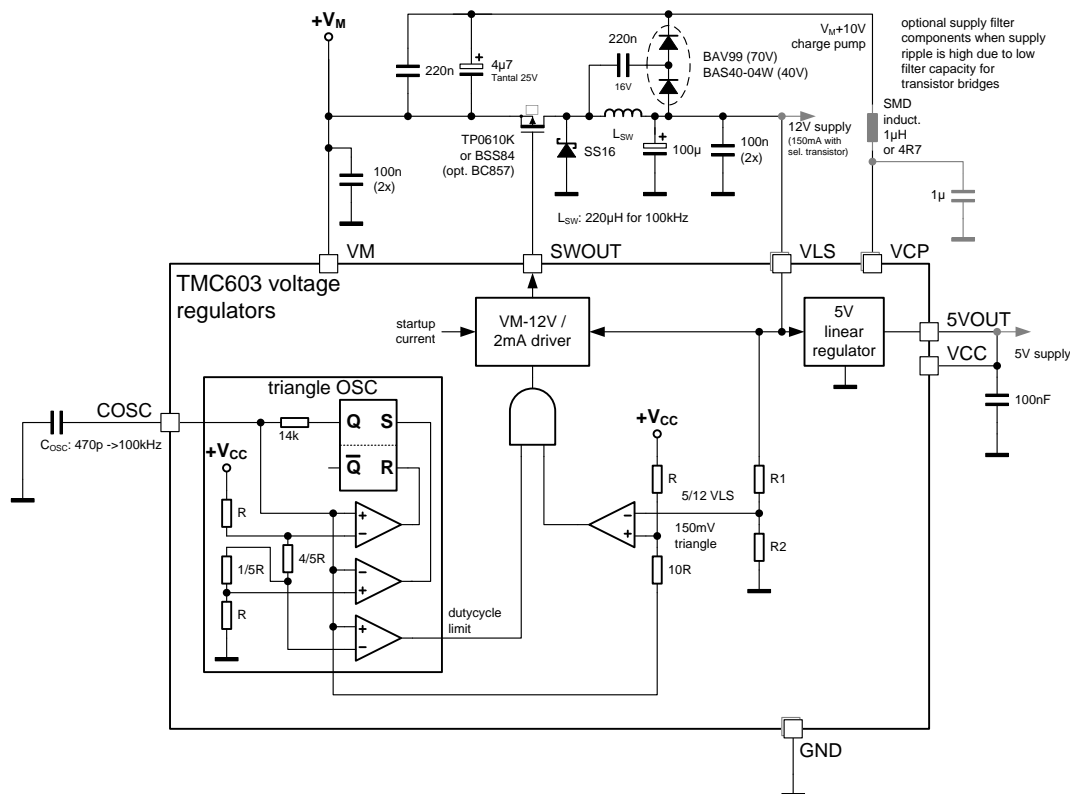

figure 18: power supply block

Pin	Comments
COSC	Oscillator capacitor for step down regulator. A 470pF capacity gives 100kHz operation. Do not leave this pin unconnected. Tie to GND, if oscillator is not used.
SWOUT	Switch regulator transistor output. The output allows driving of a small signal P-channel MOSFETs as well as PNP small signal transistors
5VOUT	Output of internal 5V linear regulator. Provided for VCC supply

5.5.1 Switching regulator and charge pump

The switching regulator has been designed for high stability. It provides an upper duty cycle limit, in order to ensure switching operation even at low supply voltage. This allows the combination with a Villard voltage doubler. The application schematic shows a number of standard values, however, the coil and oscillator frequency can be altered:

The choice of the external switching regulator transistor depends on the desired load current and the supply voltage. Especially for high switching frequencies, a low gate charge MOSFET is required. The following table shows an overview of available transistors and indicative operation limits. For a higher output current, two transistors can be used in parallel. In this case the switching frequency should be halved, because of the higher gate charge leading to slower switching slopes.

transistor type	manufacturer	gate charge (typ.)	max. frequency	max. voltage	max. load current
BC857	div.	- (bipolar)	100 kHz	40V	80 mA
BSS84	Fairchild, NXP	0.9 nC	300 kHz	50V	120 mA
TP0610K	Vishay	1.3 nC	230 kHz	60V	150 mA
NDS0605	Fairchild	1.8 nC	175 kHz	60V	150 mA
TP0202K	Vishay	1 nC	300 kHz	30V	350 mA

For the catching diode, use a Schottky type with sufficient voltage and current rating.

The choice of a high switching frequency allows the use of a smaller and less expensive inductor as well as a lower capacitance for the Villard circuit and the switching regulator output capacitor. However, the combination of inductor, transistor and switching frequency should be carefully selected and should be adapted to the load current, especially if a high load current is desired.

Choice of capacitor for the switching frequency (examples):

C _{osc}	frequency f _{osc}	inductivity example	Remark
470 pF	100 kHz	220 µH	
220 pF	175 kHz	150 µH	
100 pF	300 kHz	100 µH	Not recommended for V _{VM} < 14V

The switcher inductivity shall be chosen in a way, that it can sustain part of the load current between each two switching events. If the inductivity is too low, the current will drop to zero and higher frequency oscillations for the last part of each cycle will result (discontinuous mode). The required transistor peak current will rise and thus efficiency falls.

For a low load current, operation in discontinuous mode is possible. If a high output current is required, a good design value for continuous mode is to target a current ripple in the coil of +/-40%.

To give a coarse hint on the required inductor you can use the following formula for calculating the minimum inductivity required for continuous operation, based on a ripple current which is 100% of the load current:

$$L_{SW} = \frac{12V}{I_{OUT} * f_{OSC}} * \frac{V_{VM} - 12V}{V_{VM}}$$

V_{VM} is the supply voltage. For low voltage operation (15V or less), the output voltage sinks from 12V to 0.85*V_{VM}. The formula can be adapted accordingly.

I_{OUT} is the current draw at 12V.

For 40% current ripple, you can use roughly the double inductivity.

If ripple is not critical, you can use a much smaller inductivity, e.g. only 5% to 50% of the calculated value. But at the same time switching losses will rise and efficiency and current capability sink due to higher losses in the switching transistor. If the TMC603 does not supply additional external circuitry, current draw is very low, about 20mA in normal operation. This would lead to large inductivity values. In this case we recommend going for the values given in the table above in order to optimize coil cost.

Example:

$$f_{\text{OSC}} = 175 \text{ kHz}, I_{\text{OUT}} = 0.2 \text{ A}, V_{\text{VM}} = 48 \text{ V:}$$

$$L_{\text{SW}} = \frac{12\text{V}}{0.2\text{A} * 175000\text{Hz}} * \frac{48\text{V} - 12\text{V}}{48\text{V}} = 257\mu\text{H}$$

For continuous operation, a 330 μH or 470 μH coil would be required. The minimum inductivity would be around 100 μH .

Note:

Use an inductor, which has a sufficient nominal current rating. Keep switching regulator wiring away from sensitive signals. When using an open core inductor, please pay special care to not disturbing sensitive signals.

5.5.2 Charge pump

The Villard voltage doubler circuit relies on the switching regulator generating a square wave at the switching transistor output with a height corresponding to the supply voltage. In order to work properly the load drawn at +12V needs to be higher than the load drawn at the charge pump voltage. This normally is satisfied when the IC is supplied by the step down regulator. For low voltage operation, the charge pump voltage needs to be as high as possible to guarantee a high gate drive voltage, thus, a dual Schottky diode should be used for the charge pump in low voltage applications.

5.5.3 Supply voltage filtering

As with most integrated circuits, ripple on the supply voltage should be minimized in order to guarantee a stable operation and to avoid feedback oscillations via the supply voltages. Therefore, use a ceramic capacitor of 100nF per supply voltage pin (VM to GND, VLS to GND and VCC to GND and VCP to VM). Please pay attention to also keep voltage ripple on VCC pin low, especially when the 5V output is used to supply additional external circuitry. It also is important to make sure, that the resistance of the power supply is low when compared to the load circuit. Especially high frequency voltage ripple >1MHz should be suppressed using filter capacitors near the power bridge or near the board power supply. The VM terminal is used, to detect short to GND situations, thus, it has to correspond to the bridge power supply. In high noise applications, it may make sense to filter VCP supply separately against ripple to GND. A large low ESR electrolytic capacitor across the bridge supply (VM to GND) should also be used, because it effectively suppresses high frequency ripple. This cannot be accomplished with ceramic capacitors.

5.5.4 Reverse polarity protection

Some applications need to be protected against a reversed biased power supply, i.e. for automotive applications. A highly efficient reverse polarity protection based on an N channel MOSFET can simply be added due to the availability of a charge pump voltage. This type of reverse polarity protection allows feeding back energy into the supply, and thus is preferable to a pure diode reverse polarity protection.

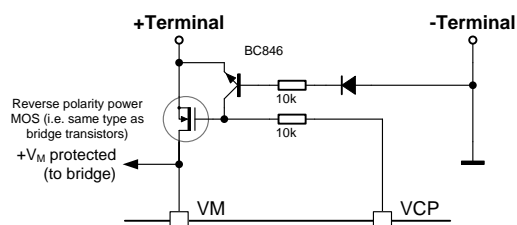

figure 19: adding a reverse polarity protection

5.5.5 Standby with zero power consumption

In battery powered applications, a standby function often is desired. It allows switching the unit on or off without the need for a mechanical high power switch. In principle, the bridge driver MOSFETs can switch off the motor completely, but the TMC603 and its switching regulator still need to be switched off in order to reduce current consumption to zero. Only a low energy standby power supply will remain on, in order to wake up the system controller. This standby power supply can be generated by a low current zener diode plus a resistor to the battery voltage, buffered by a capacitor. The example in the schematic uses a P channel MOSFET to switch off power for the TMC603 and any additional

ICs which are directly supplied by the battery. In order to safely switch off the motor bridges during standby, the gates of the high side MOSFETs become actively held in a discharged state using a low current signal MOSFET in SOT23 package. Before entering standby mode, the motor shall be stopped and the TMC603 should be disabled.

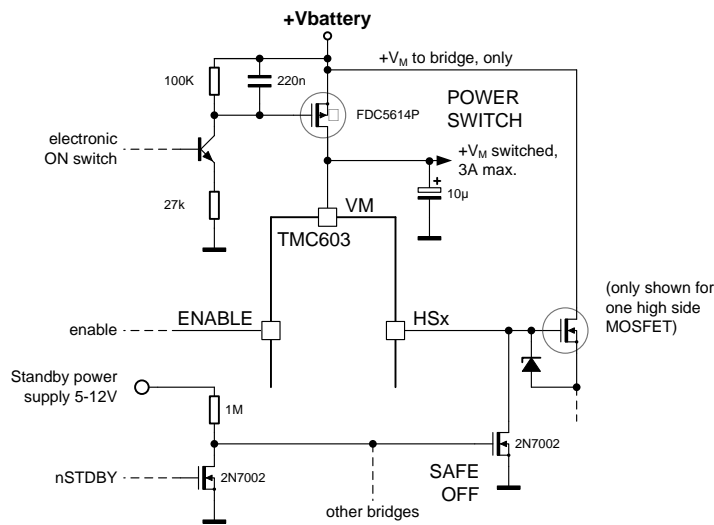

figure 20: low power standby

5.5.6 Low voltage operation down to 9V

In low voltage operation, it is important to keep the gate driving voltages as high as possible. The switching regulator for VLS thus is not needed and can be left out. Tie the pin COSC to GND. VLS becomes directly tied to +VM, which is possible as long as the supply voltage does not exceed 14V (16V peak). However, now a source for the Villard voltage doubler is missing. A simple solution is to use a CMOS 555 timer circuit (e.g. TLC555) oscillating at 250 kHz (square wave) to drive the voltage doubler.

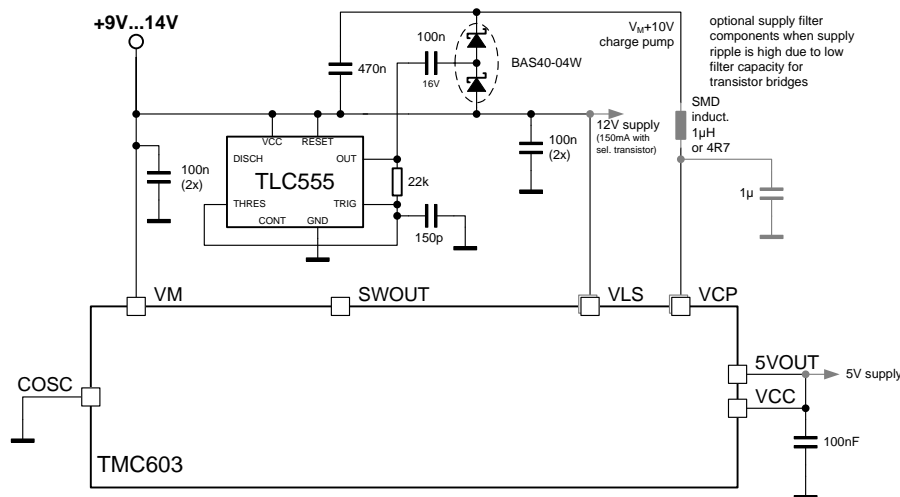

figure 21: low voltage operation

5.6 Test output

The test output is reserved for manufacturing test. Leave open for a normal application.

Pin	Comments
TEST	Output for test voltages. Output resistance 25kOhm +-30%. Reset: ENABLE(=low); Clock: SCCLK (rising edge). Test voltage sequence: 0: 0V 1..3 / 4..6 / 7..9: Gate_HS_Off, Gate_LS_On, Gate_LS_Off (driver 1/2/3) 10..14: currently unused 15: 0V (no further counts: Reset for restart)

6 Absolute Maximum Ratings

The maximum ratings may not be exceeded under any circumstances. Operating the circuit at or near more than one maximum rating at a time for extended periods shall be avoided by application design.

Parameter	Symbol	Min	Max	Unit
Supply voltage	V_{VM}	-0.5	50	V
Supply and bridge voltage max. 20000s			55	V
Low side driver supply voltage	V_{VLS}	-0.5	14	V
Low side driver supply voltage max. 20000s	V_{VLS}	-0.5	16	V
Charge pump voltage (related to GND)	V_{VCP}	-0.5	60	V
Charge pump voltage max. 20000s			65	V
Charge pump voltage during power up / down		V_M-10	V_M+16	V
Logic supply voltage	V_{VCC}	-0.5	6.0	V
Logic input voltage	V_I	-0.5	$V_{CC}+0.5$	V
Analog input voltage	V_{IA}	-0.5	$V_{CC}+0.5$	V
Voltages on driver pins (HSx, LSx, BMx)	V_{DRVIO}	-0.7	0.7	V
Relative high side driver voltage ($V_{HSX} - V_{BMX}$)	V_{HSBM}	-20	20	V
Maximum current to / from digital pins and analog low voltage I/Os	I_{IO}		+/-10	mA
5V regulator continuous output current	I_{5VOUT}		40	mA
5V regulator short time output current	I_{5VOUT}		150	mA
Junction temperature	T_J	-50	150	°C
Storage temperature	T_{STG}	-55	150	°C
ESD-Protection (Human body model, HBM)	V_{ESD}		1	kV

7 Electrical Characteristics

7.1 Operational Range

Parameter	Symbol	Min	Max	Unit
Ambient temperature	T_A	-40	125	°C
Junction temperature	T_J	-40	140	°C
Supply voltage (standard circuit)	V_{VM}	10	50	V
Supply voltage (low voltage application: $V_{VLS}=V_{VM}$)		9	14	V
Low side driver supply voltage	V_{VLS}	9	13	V
Differential charge pump voltage measured to VM ($V_{VCP} - V_{VM}$)	V_{CPD}	8	12	V
Logic supply voltage	V_{VCC}	4.75	5.25	V
Slope control resistor with $V_{VM} < 30V$	R_{SLP}	60	500	k Ω
Slope control resistor with $V_{VM} > 30V$	R_{SLP}	100	500	k Ω
Short to GND control resistor	R_{S2G}	47	1000	k Ω
Output slope	t_{SLP}	100	1000	ns

7.2 DC Characteristics and Timing Characteristics

DC characteristics contain the spread of values guaranteed within the specified supply voltage range unless otherwise specified. Typical values represent the average value of all parts measured at +25°C. Temperature variation also causes stray to some values. A device with typical values will not leave Min/Max range within the full temperature range.

NMOS low side driver <i>note 1)</i>	DC-Characteristics $V_{VCC} = 5.0\text{ V}$, $V_{VLS} = 12\text{ V}$					
Parameter	Symbol	Conditions	Min	Typ	Max	Unit
Gate drive current LSx low side switch ON	I_{LSON}	$V_{LSX} = 5\text{ V}$ $R_{SLP} = 68\text{ k}$	125	150	180	mA
Gate drive current LSx low side switch OFF	I_{LSOFF}	$V_{LSX} = 5\text{ V}$ $R_{SLP} = 68\text{ k}$	-125	-160	-190	mA
Gate drive current LSx low side switch ON	I_{LSON}	$V_{LSX} = 5\text{ V}$ $R_{SLP} = 100\text{ k}$	88	105	126	mA
Gate drive current LSx low side switch OFF	I_{LSOFF}	$V_{LSX} = 5\text{ V}$ $R_{SLP} = 100\text{ k}$	-90	-115	-138	mA
Gate drive current LSx low side switch ON	I_{LSON}	$V_{LSX} = 5\text{ V}$ $R_{SLP} = 220\text{ k}$		50		mA
Gate drive current LSx low side switch OFF	I_{LSOFF}	$V_{LSX} = 5\text{ V}$ $R_{SLP} = 220\text{ k}$		-50		mA
Gate Off detector threshold	V_{GOD}	V_{LSX} falling		1		V
Q_{GD} protection resistance after detection of gate off	$R_{LSOFFQGD}$	$V_{LSX} = 2\text{ V}$		15		Ω
Delay LS driver switch on BLx to LSx at 50%	t_{LSON}	$R_{SLP} = 100\text{ k}$ $C_{LSX} = 100\text{ pF}$	35	70	140	ns
Delay LS driver switch off BLx to LSx at 50%	t_{LSOFF}	$R_{SLP} = 100\text{ k}$ $C_{LSX} = 100\text{ pF}$	80	160	320	ns

NMOS high side driver <i>note 1)</i>	DC-Characteristics $V_{VCC} = 5.0\text{ V}$, $V_{VLS} = 12\text{ V}$, $V_{CPD} = 10.5\text{ V}$					
Parameter	Symbol	Conditions	Min	Typ	Max	Unit
Gate drive current HSx high side switch ON	I_{HSON}	$V_{HSX} = 5\text{ V}$ $R_{SLP} = 68\text{ k}$	112	135	180	mA
Gate drive current HSx high side switch OFF	I_{HSOFF}	$V_{HSX} = V_M + 5\text{ V}$ $R_{SLP} = 68\text{ k}$	-120	-150	-180	mA
Gate drive current HSx high side switch ON	I_{HSON}	$V_{HSX} = 5\text{ V}$ $R_{SLP} = 100\text{ k}$	75	90	120	mA
Gate drive current HSx high side switch OFF	I_{HSOFF}	$V_{HSX} = V_M + 5\text{ V}$ $R_{SLP} = 100\text{ k}$	-80	-100	-120	mA
Gate drive current HSx high side switch ON	I_{HSON}	$V_{HSX} = 5\text{ V}$ $R_{SLP} = 220\text{ k}$		50		mA
Gate drive current HSx high side switch OFF	I_{HSOFF}	$V_{HSX} = V_M + 5\text{ V}$ $R_{SLP} = 220\text{ k}$		-50		mA
Gate Off detector threshold high side $V_{HSX} - V_{BMX}$, BM level high	V_{GOD}	V_{HSX} falling $V_{BMX} > V_{GOBM}$		0		V
Gate Off detector threshold high side V_{BMX} , BM level low	V_{GOBM}	V_{BMX} falling		3.5		V
Q_{GD} protection current after detection of gate off	$I_{HSOFFQGD}$	$V_{BMX} = 24\text{ V}$ $V_{HSX} = V_{BMX} + 2\text{ V}$		300		mA
Delay HS driver switch on BHx to HSx at 50%	t_{HSON}	$R_{SLP} = 100\text{ k}$ $V_M = 24\text{ V}$ $C_{HSX} = 100\text{ pF}$	75	150	300	ns
Delay HS driver switch off BHx to HSx at 50%	t_{HSOFF}	$R_{SLP} = 100\text{ k}$ $V_M = 24\text{ V}$ $C_{HSX} = 100\text{ pF}$	60	120	240	ns

Break-before-make block <i>note 1)</i>	Timing-Characteristics $V_M = 48\text{ V}$, $R_{SLP} = 100\text{ K}$					
Parameter	Symbol	Conditions	Min	Typ	Max	Unit
Break-before-make delay LSx off to HSx on	t_{BBMLH}	Measured at 1V gate-source voltage		160		ns
Break-before-make delay HSx off to LSx on	t_{BBMHL}	Measured at 1V gate-source voltage		290		ns

1) See timing diagram in figure 6: bridge driver timing

RSLP input and RS2G input		DC-Characteristics				
$V_{VCC} = 5.0 \text{ V}$						
Parameter	Symbol	Conditions	Min	Typ	Max	Unit
Typical voltage at RSLP and RS2G input, depending on the external resistor	V_{RSLP} V_{RS2G}	$R_{SLP} = 100 \text{ k}\Omega$ $R_{S2G} = 100 \text{ k}\Omega$		3.8		V
		$R_{SLP} = 470 \text{ k}\Omega$ $R_{S2G} = 470 \text{ k}\Omega$		4.0		

Short to GND detector		DC-Characteristics, Timing-Characteristics				
$V_{VM} = 24 \text{ V}$						
Parameter	Symbol	Conditions	Min	Typ	Max	Unit
Short to GND detection level ($V_{VM} - V_{BM}$)	V_{BMS2G}		1	1.5	2.3	V
Short to GND detector delay (HSx going active to short detector active / ERR_OUT falling)	t_{S2G}	$R_{S2G} = 68\text{k}$	200	320	450	ns
		$R_{S2G} = 150\text{k}$	500	750	1000	ns
		$R_{S2G} = 220\text{k}$	700	1000	1300	ns
		$R_{S2G} = 470\text{k}$	1400	2000	2600	ns

Supply current		DC-Characteristics				
$V_{VCC} = 5.0 \text{ V}$, $V_{VLS} = 12\text{V}$, $V_{CPD} = 10.5\text{V}$, $R_{SLP} = 100\text{k}$, $V_{VM} = 48\text{V}$						
Parameter	Symbol	Conditions	Min	Typ	Max	Unit
VM supply current	I_{VM}			0.45	0.68	mA
VLS supply current	I_{VLS}	not including I_{5VOUT}		4.6	6.9	mA
VCP supply current	I_{VCP}			1.6	2.4	mA
VCC supply current	I_{VCC}			2.9	4.4	mA

Undervoltage detectors		DC-Characteristics				
$V_{VCC} = 5.0 \text{ V}$						
Parameter	Symbol	Conditions	Min	Typ	Max	Unit
VLS undervoltage level	V_{VLSUV}		7	7.85	8.5	V
VCP undervoltage level ($V_{VCP} - V_{VM}$)	V_{CPDUV}	V_{VCP} falling	5.8	6.6		V
VCP voltage OK level ($V_{VCP} - V_{VM}$)		V_{VCP} rising		7.1	7.8	V
VCP undervoltage detector Hysteresis				0.5		V

Switching regulator / Charge pump	DC-Characteristics					
	$V_{VCC} = V_{5VOUT}$					
Parameter	Symbol	Conditions	Min	Typ	Max	Unit
Switch output drive current (on)	I_{SWOUT}	$V_{SWOUT} = V_{VM}$	-1.5	-2.2	-3.0	mA
Switch output drive current (off)	I_{SWOUT}	$V_{SWOUT} = V_{VM} - 5V$		10		mA
Switch start-up drive current during VCC undervoltage	I_{SWOUT}	$V_{SWOUT} = V_{VM}$ $V_{VM} = 24V$ $V_{VLS} < 2V$	-0.4	-0.8		mA
Switch output drive voltage (on) $V_{VM} - V_{SWOUT}$	V_{SWOUT}	$I_{SWOUT} = 0$	8	12	15	V
Switch regulator output voltage	V_{12VOUT}	$V_{VM} > 16V$	11	12	13.1	V
		$V_{VLSUV} < V_{VM} < 16V$		$0.85 V_{VM}$		V
Oscillator output resistance	R_{COSC}	$T_J = 25^\circ C$		14.1		k Ω
Lower oscillator threshold voltage	V_{COSC}			$1/3 V_{VCC}$		V
Upper oscillator threshold voltage	V_{COSC}			$2/3 V_{VCC}$		V
Oscillator threshold voltage for maximum duty cycle limit	V_{COSC}			$6/15 V_{VCC}$		V
Maximum duty cycle switch regulator	DC_{SWOUT}	$V_{VLS} = 10V$ $f_{CHOP} = 100kHz$	63	70	77	%
Chopper frequency nominal	f_{CHOP}	$C_{OSC} = 470pF$	70	100	130	kHz
Chopper frequency range (design reference value only)	f_{CHOP}		0 (off)		300	kHz
Charge pump voltage (design reference value only)	V_{CPD}	$V_{VLS} = 12V$ $I_{VCP} = 1.6mA$		10.6		V

Linear regulator	DC-Characteristics					
	Parameter	Symbol	Conditions	Min	Typ	Max
Output voltage	V_{5VOUT}	$I_{5VOUT} = 10mA$ $T_J = 25^\circ C$	4.75	5.0	5.25	V
Output resistance	R_{5VOUT}	Static load		2		Ω
Output current capability	I_{5VOUT}	$V_{VLS} = 12V$	100			mA
		$V_{VLS} = 8V$	60			mA
		$V_{VLS} = 6.5V$	20			mA

Digital logic level	DC-Characteristics $V_{VCC} = 5.0 \text{ V } +/-10\%$					
Parameter	Symbol	Conditions	Min	Typ	Max	Unit
Input voltage low level	V_{INLO}		-0.3		0.8	V
Input voltage high level	V_{INHI}		2.0		$V_{VCC}+0.3$	V
Output voltage low (H1, H2, H3, ERR_OUT)	V_{OUTLO}	$I_{OUTLO} = 1\text{mA}$			0.4	V
Output voltage high (H1, H2, H3)	V_{OUTH}	$I_{OUTH} = -1\text{mA}$	$0.8V_{VCC}$			V

Current measurement block	DC-Characteristics, Timing-Characteristics					
	$V_{VM} = 24\text{ V}, V_{VCC} = 5.0\text{ V}$					
Parameter	Symbol	Conditions	Min	Typ	Max	Unit
Amplification of voltage V_{BMX} to V_{CURX} for positive voltage ($V_{BMX} > 0V$)	A_{CURLO+}	SENSE_HI = GND	-4.3	-4.6	-4.9	V/V
	A_{CURHI+}	SENSE_HI = VCC	-17	-18.0	-19	V/V
Amplification of voltage V_{BMX} to V_{CURX} for negative voltage ($V_{BMX} < 0V$)	A_{CURLO-}	SENSE_HI = GND	-4.1	-4.4	-4.7	V/V
	A_{CURHI-}	SENSE_HI = VCC	-16	-17.1	-18	V/V
Zero current level at CURX	V_{0CURX}		$V_{VCC}/3$ -50mV	$V_{VCC}/3$	$V_{VCC}/3$ +50mV	V
Measurement voltage range at V_{BMX}	V_{BMX}	SENSE_HI = GND	-250		250	mV
		SENSE_HI = VCC	-60		60	mV
Ripple voltage / hold step noise at output <i>note 2)</i>	V_{CURX}	$V_{BMX} = 0V$ SENSE_HI = GND		17	26	mV
		$V_{BMX} = 0V$ SENSE_HI = VCC		50	75	mV
Minimum low side on time for current measurement (Delay from BLx going active to CURx tracking amplified signal)	$t_{BLHICURX}$	SAMPLEx = VCC	3.5	5.3	7.2	μs
Delay from SAMPLEx going active to CURx tracking amplified signal	$t_{SMPHICURX}$	SAMPLEx = VCC		$t_{BLHICURX} / 2$		μs
Delay from BLx or SAMPLEx going inactive to CURx hold	t_{BLXLO}			0		μs
Sample and hold drop during hold period	dV_{CURX}			0.001	1.6	V/s
Auto zero drop of current amplifier during sampling period (low side on)	dV_{CURX}			0.003	3	V/s
Minimum initial auto zero period (low side off or SAMPLEx low) after power on	t_{BLXLOO}		5			μs
Minimum sample period after $t_{BLHICURX}$ for a 100% current step	$t_{BLXHIADD}$		1			μs
Output current limit at CURx	I_{CURX}	Current sourcing	0.45			mA

2) Note on first ICs dated before 20/2009:

CURx outputs are sensible to ripple voltage on VCC pin and frequency below 5MHz. Ripple voltage is amplified by $1/3 \cdot \text{Set amplification}$, i.e. factor 1.5 with SENSE_HI low and factor 6 with SENSE_HI high. Thus, it is suggested to use 5VOUT only for VCC supply, if possible, if exact measurements are required.

Switched capacitor filter 2 nd order		DC-Characteristics, AC-Characteristics				
$V_{VM} = 24 \text{ V}, V_{VCC} = 5.0 \text{ V}$						
Parameter	Symbol	Conditions	Min	Typ	Max	Unit
Attenuation of voltage V_{BMX} to V_{FILTX}	A_{FILTX}	$V_{BMX} > 0.9\text{V}$		$V_{BMX}/15 - 0.9\text{V}$		V
Output resistance of FILTX	R_{FILTX}		21	30	40	k Ω
Output current limit at FILTX	I_{FILTX}	Current sourcing	20			μA
Noise voltage on FILTX	$V_{FILTXNOISE}$	$V_{BMX} = 12\text{V}$ $f_{SCCLK} = 1.25\text{MHz}$		20		mV
3dB bandwidth	f_{CUTOFF}			$1/390 f_{SCCLK}$		Hz
		$f_{SCCLK} = 1.25\text{MHz}$	3.0	3.2	3.4	kHz
		$f_{SCCLK} = 2.5\text{MHz}$		6.4		kHz
Switched capacitor filter clock frequency for normal operation	f_{SCCLK}		0.25		4	MHz

hallFX unit		DC-Characteristics, AC-Characteristics				
$V_{VM} = 24 \text{ V}, V_{VCC} = 5.0 \text{ V}$						
Parameter	Symbol	Conditions	Min	Typ	Max	Unit
Noise voltage of comparators including switched capacitor filter	$V_{COMPNOISE}$	$V_{BMX} = 12\text{V}$		50	150	mV
Offset voltage of comparators including switched capacitor filter and input attenuation	$V_{COMPOFFS}$	$V_{BMX} = 12\text{V}$	-300	0	300	mV
Spike suppression comparator threshold	V_{SP_SUP}	V_{SP_SUP} rising	2.0	$V_{VCC}/2$	2.8	V
Spike suppression capacitor charging current	I_{SP_SUP}	$V_{SP_SUP} = 1\text{V}$	15	25	35	μA
Spike suppression capacitor discharging current	I_{SP_SUP}	$V_{SP_SUP} = 1\text{V}$	-0.5	-1	-1.5	mA
Dead time for spike suppression	t_{SP_SUP}	$C_{SP_SUP} = 1\text{nF}$	60	100	180	μs

8 Designing the application

8.1 Choosing the best fitting power MOSFET

There is a huge choice of power MOSFETs available. MOSFET technology has been improved dramatically in the last 20 years, and gate drive requirements have shifted from generation to generation. The first generations of MOSFETs have a comparatively high gate capacity at a moderate R_{DSon} . Their gate-source capacity is two to five times as high as the capacity of the gate-drain junction. These MOSFETs have a high gate charge and thus require high current gate drive, but they are easy to use, because internal feedback is low. In the early 2000s new MOSFETs have emerged, where R_{DSon} is much lower, and gate-source capacity has been improved by minimizing structural overlap. Thus, the capacitance ratio has shifted, and feedback has become quite high. These MOSFETs thus are much more critical, and power drives have to actively force the gate off to prevent the bridges from cross-conduction due to feedback from the drain to gate. Latest generation MOSFETs, like the Vishay W-Fet technology, further reduce R_{DSon} , while reducing the capacity between the channel and the drain. Thus, these MOSFETs have lowest gate charge, and again, are easier to control than the previous generation of MOSFETs.

When choosing the MOSFET, the following points shall be considered:

- **Maximum voltage:**
Choose at least a few volts above your maximum supply voltage, taking into account that the motor can feed back energy when slowing down, and thus the supply voltage can rise. On the other hand, a transistor rated for a higher voltage is more expensive and has a higher gate charge (see next chapter).
- **R_{DSon} :**
A low R_{DSon} gives low static dissipation, but gate charge and cost increases. Take into account, that a good part of the power dissipation results from the switching events in a chopped drive system. Further, to allow a current measurement, the R_{DSon} should be in a range, that the voltage drop can be used for measurement. A voltage drop of 50mV or higher at nominal motor current is a good target.
- **Gate charge and switching speed:**
The switching speed should be compared to the required chopper frequency. Choose the chopper frequency low to reduce dynamic losses. When the application does not require slow, EMV optimized switching slopes, choose a low gate charge transistor to reduce dynamic losses.
- **Gate threshold voltage:**
Most MOSFETs have a specified on-resistance at a gate drive voltage of 10V. Some MOSFETs are optimized for direct control from logic ICs with 5 or even 3.3V. They provide a low gate threshold voltage of 1V to 2V. MOSFETs with higher gate threshold voltage should be preferred, because they are less sensible to effects of the drain gate capacity and cross conduction.
- **Package, size and cooling requirements**
- **Cost and availability**

8.1.1 Calculating the MOSFET power dissipation

The power dissipation in the MOSFETs has three major components: Static losses (P_{STAT}) due to voltage drop, switching losses (P_{DYN}) due to signal rise and fall times, losses due to diode conduction (P_{DIODE}). The diode power dissipation depends on many factors (back EMF of the motor, inductivity and motor velocity), and thus is hard to calculate from motor data. Normally, it contributes for a few percent to some ten percent of overall power dissipation. Other sources for power dissipation are the reverse recovery time of the transistors and the gate drive energy. Reverse recovery also causes current spikes on the bridges. If desired, you can add Schottky diodes over the (chopper) transistors to reduce the diode losses and to eliminate current spikes caused by reverse recovery.

The following sample calculation assumes a three phase BLDC motor operated in block commutation mode with dual sided chopper. At each time, two coils conduct the full motor current (chopped).

$$P_{STAT} = I_{MOTOR}^2 * 2 * R_{DSON} * t_{DUTY}$$

$$P_{DYN} = I_{MOTOR} * f_{CHOP} * t_{SLOPE} * 2 * 2 * V_{VM}/2$$

where

I_{MOTOR} is the motor current, e.g. 10A

R_{DSON} is the on-resistance of the MOSFETs at a gate voltage of about 10V, e.g. 20m Ω

t_{DUTY} is the actual duty cycle of the chopper, e.g. 80% = 0.8

V_{VM} is the motor supply voltage, e.g. 24V or 48V

f_{CHOP} is the chopper frequency, e.g. 20kHz

t_{SLOPE} is the slope (transition) time, e.g. 300ns

Example:

With the example data for a 10A motor at 24V, we get the following power dissipation:

$$P_{STAT} = 3.2W$$

$$P_{DYN24} = 2.88W$$

For comparison: The motor output power is 10A*24V*0.8=192W

The dynamic and static dissipation here are in a good ratio, thus the choice of a 20m Ω MOSFET is good.

At 48V, the dynamic power dissipation doubles:

$$P_{DYN48} = 5.76W$$

Here, the dynamic losses are higher than the static losses. Thus, we should reduce the slope time. Given that the gate capacity would not allow for faster slopes than 300ns, we could go for a 30m Ω MOSFET, which has a lower gate charge and thus allows faster slopes, e.g. 200ns. With these modifications we get a static loss of 4.8W and a dynamic loss of 3.84W. This in sum is 8.64W, which is slightly less than the 8.96W before. At the same time, system cost has decreased due to lower cost MOSFETs. The loss is still low when compared to a motor power of 384W.

8.2 MOSFET examples

There is a huge number of MOSFETs on the market, which can be used in combination with the TMC603. The user choice will depend on the electrical data (voltage, current, RDSon) and on the package and configuration (single / dual). The following table gives a few examples of SMD MOSFETs for different motor currents. The MOSFETs explicitly are modern types with a low total gate charge. With dual configurations, only three MOSFET packages are required to control a BLDC motor, but the current which can be reached is significantly lower due to thermal restrictions of the packages.

For the actual application, we suggest to calculate static and dynamic power dissipation for a given MOSFET, as described in the previous chapter. Especially for sine commutation and chopper frequencies above 20kHz, transistors with a gate charge below 100nC should be preferred.

Transistor type	manufacturer	RDSon	voltage	package & configuration	max. motor current (*)	total gate charge @10V
unit		mΩ	V		A	nC
IBP019N06L3	Infineon	1.9	60	DPAK	30	124
SiE812DF	Vishay	2.6	40	PolarPAK	30	52
IPP032N06N3	Infineon	2.9	60	TO220	30	125
IRFB3306	International Rectifier	4.2	60	TO220 / DPAK	30	85
SiE816DF	Vishay	7.4	60	PolarPAK	20	51
SUM75N06-09L	Vishay	9.3	60	D2PAK (TO263)	25	47
FDD10AN06A0	Fairchild	10.5	60	DPAK (TO252A)	20	28
FDD5353	Fairchild	12.3	60	DPAK	15	46
SI7964DP	Vishay	23	60	PowerPAK-SO8 (dual)	9.6	43
SI4946	Vishay	55	60	SO8 (dual)	4.5	19

(*) Remark: The maximum motor current applicable in a given design depends upon PCB size and layout, since all of these transistors are mainly cooled via the PCB. The data given implies adequate cooling measures taken by the user, especially for higher current designs.

8.3 Driving a DC motor with the TMC603

The TMC603 can also be used for DC motor applications, using a full bridge or a half bridge for motor PWM operation with or without reverse direction operation. For single half bridge applications, all TMC603 gate drivers can be paralleled, taking advantage of the three time increase in gate drive capability. This way a motor current of up to 100A can be driven. The drive system can use the shunt less current sensing capability for best efficiency. A Schottky diode across the non-chopped transistor optimizes slopes and electromagnetic emission characteristics (see chapter 5.2.8).

9 Table of figures

FIGURE 1: APPLICATION BLOCK DIAGRAM	5
FIGURE 2: PINNING / QFN52 PACKAGE (TOP VIEW).....	6
FIGURE 3: APPLICATION DIAGRAM.....	8
FIGURE 4: THREE PHASE BLDC DRIVER.....	10
FIGURE 5: PRINCIPLE OF HIGH-SIDE DRIVER (PAT.FIL.)	10
FIGURE 6: BRIDGE DRIVER TIMING	12
FIGURE 7: EXAMPLES FOR MICROCONTROLLER PWM CONTROL.....	13
FIGURE 8: MOSFET GATE CHARGE AS AVAILABLE IN DEVICE DATA SHEET VS. SWITCHING EVENT	13
FIGURE 9: QGD PROTECTED DRIVER STAGE	14
FIGURE 10: EFFECT OF BULK DIODE RECOVERY.....	16
FIGURE 11: PARALLEL SCHOTTKY DIODE AVOIDS CURRENT SPIKES DUE TO BULK DIODE RECOVERY	17
FIGURE 12: TIMING OF THE SHORT TO GND DETECTOR	17
FIGURE 13: ERROR LOGIC	18
FIGURE 14: SCHEMATIC OF CURRENT MEASUREMENT AMPLIFIERS	19
FIGURE 15: TIMING OF THE CURRENT MEASUREMENT	20
FIGURE 16: HALLFX BLOCK DIAGRAM AND TIMING.....	21
FIGURE 17: HALLFX BASED COMMUTATION	23
FIGURE 18: POWER SUPPLY BLOCK	25
FIGURE 19: ADDING A REVERSE POLARITY PROTECTION.....	27
FIGURE 20: LOW POWER STANDBY	28
FIGURE 21: LOW VOLTAGE OPERATION	28

10 Revision History

10.1 Documentation Revision

Version	Author	Description
0.94	BD	TMC603 initial release with preliminary electrical data
0.96	BD	Added package dimensions
0.98	BD	Added microcontroller PWM control examples
0.99	BD	Added reverse polarity protection and MOSFET examples
1.00	BD	Added low power standby and low voltage operation
1.01	BD	Removed "preliminary" indication, modifications in electrical characteristic tables
1.02	BD	Slightly corrected a few values
1.03	BD	Added transistor examples and temperature information to tables
1.04	BD	Slight beautifications / rewording
1.05	BD	Added mathematical background for QGD protection, discussion on MOSFET bulk diode and DC motor application

Table 1: Documentation Revisions