



CMUcam3 Datasheet

September 22, 2007

This page intentionally left blank.

Contents

1. INTRODUCTION	1
Features	1
Applications	2
2. BLOCK DIAGRAM	3
3. HARDWARE CONNECTIONS	4
Power.....	5
Serial Port.....	6
Camera Bus.....	7
Servo Port.....	8
Expansion Port GPIO	9
Analog Output Port	11
LEDs.....	12
ISP Button.....	13
4. HARDWARE CHARACTERISTICS.....	14
5. INSTALLING FIRMWARE	15
Windows	15
Linux	18
6. ASSEMBLY INFORMATION	19
Top Placement (Rev. A)	19
Bottom Placement (Rev. A).....	19
Top Placement (Rev. B).....	20
Bottom Placement (Rev. B)	20
Bill of Materials	21
Part Numbers.....	22
Placement Coordinates (Revision A).....	23
Placement Coordinates (Revision B).....	24
Schematic.....	25
Dimensions.....	30
7. REVISION HISTORY	31

This is the CMUcam3 Datasheet v1.02 for the CMUcam3 Embedded Vision Sensor.

For more information go to <http://www.cmucam.org> or contact us at cmucam@cs.cmu.edu

Copyright 2006-2007 Anthony Rowe, Adam Goode and Carnegie Mellon University. All Rights Reserved.

Edited by Illah Nourbakhsh

1. INTRODUCTION

The CMUcam3 is an ARM7TDMI based fully programmable embedded computer vision sensor. The main processor is the Philips LPC2106 connected to an Omnivision CMOS camera sensor module. Custom C code can be developed for the CMUcam3 using a port of the GNU toolchain along with a set of open source libraries and example programs. Executables can be flashed onto the board using the serial port with no external downloading hardware required. Make sure to check www.cmucam.org for the most up to date documentaton and Quick-Start guides.

Features

- CIF Resolution (352x288) RGB color sensor
- Open Source Development Environment for Windows and Linux
- MMC Flash Slot with FAT16 driver support
- Four-port Servo Controller
- Load Images into Memory at 26 Frames Per Second
- LUA light-weight language interpreter allows for rapid prototyping
- Software JPEG compression
- Basic Image Manipulation Library
 - Arbitrary Image Clipping
 - Image Downsampling
 - Mutable camera image properties
 - Threshold and Convolution Functions
 - RGB, YCrCb and HSV Color Space
- CMUcam2 Emulation
 - User defined color blobs
 - Frame differencing
 - Mean and variance data collection
 - Raw images dumps over serial
 - Histogram Generation
- B/W Analog video output (PAL or NTSC)*
- FIFO image buffer for multiple pass hi-res image processing
- Compatible Connector with Wireless Motes (Tmote Sky, FireFly, 802.15.4)

* Camera Properties Depend on Camera Module

Applications

The CMUcam3 is a hardware platform coupled with an open source development environment. It is targeted toward users that are already familiar with basic image processing and who are comfortable with microcontroller programming. For users who want basic image processing accessible through a simple serial interface and do not wish to implement their own algorithms, you can install a flash utility and download CMUcam2 emulation firmware. This allows the CMUcam3 to mimic the interface provided by the CMUcam2. Refer to the CMUcam2 user manual available on the CMUcam website for more information about CMUcam2 firmware functionality. The CMUcam3 can be used for a variety of applications including: While CMUcam2 functionality can be duplicated using CMUcam3, the major benefit of CMUcam3 stems from the ability of advanced users to directly program the system with their specific algorithms, even starting from the openly available firmware for CMUcam3 that emulates a majority of the CMUcam2 functionality.

- Robotics
- Surveillance
- Sensor Networks
- Education
- Interactive Toys
- Object recognition and tracking
- Programmable Servo Control
- Serial MMC Flash Data Logging

2. BLOCK DIAGRAM

Below is a high level block diagram of the major components found on the CMUcam3.

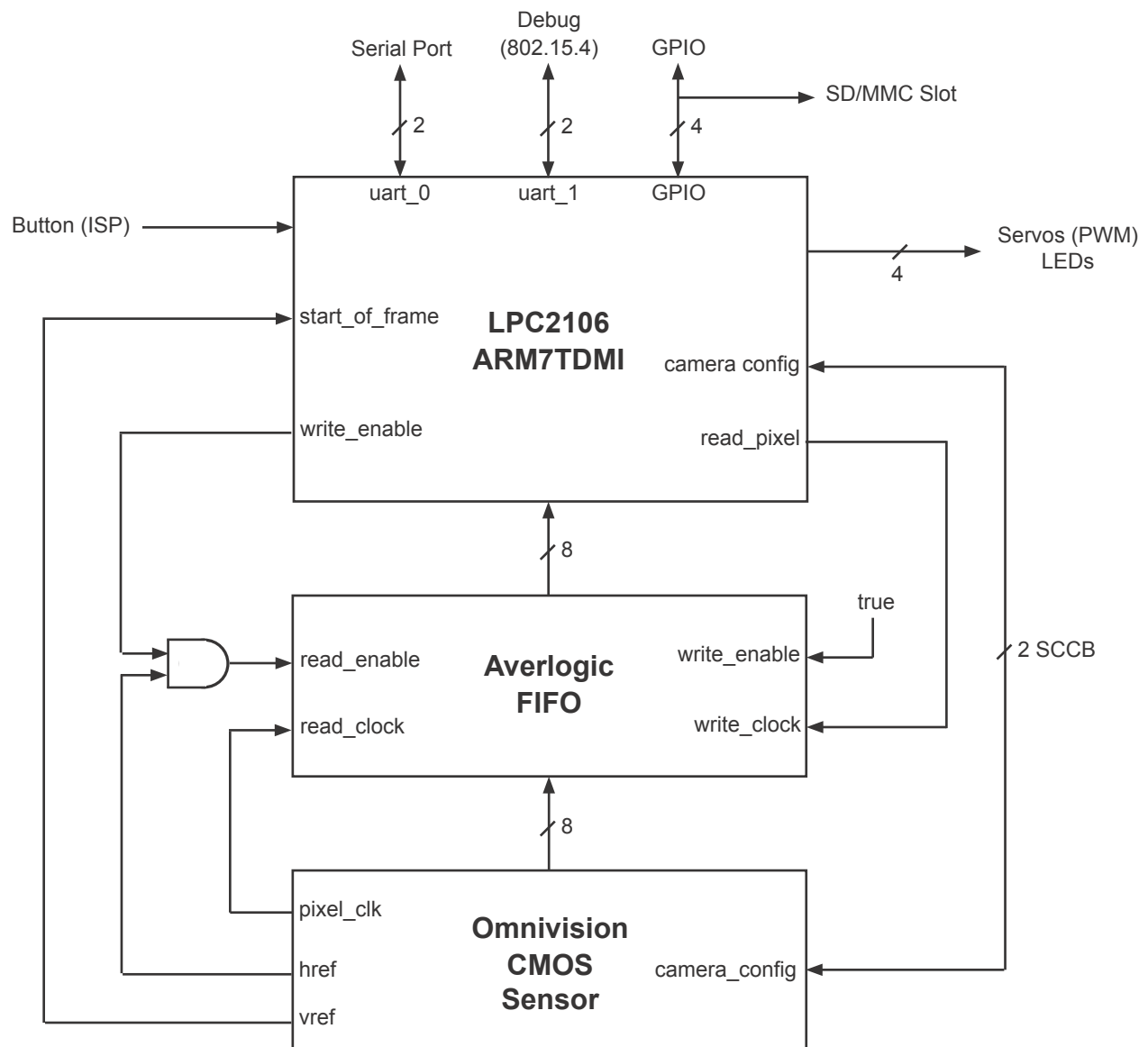

3. HARDWARE CONNECTIONS

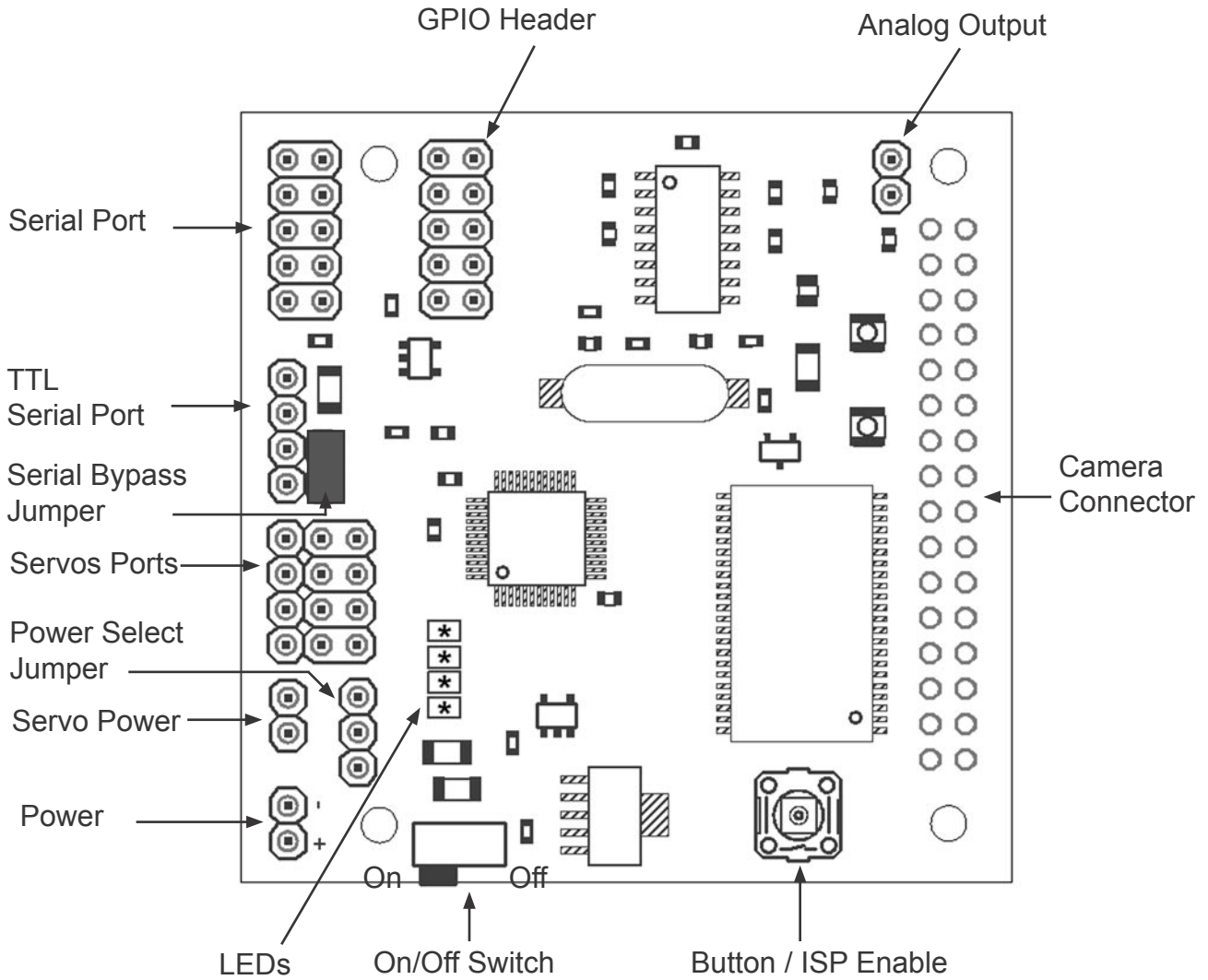

Power

The input power to the board goes through a 5 volt regulator. It is ideal to supply the board with between 6 and 15 volts of DC power that is capable of supplying at least 150 milliamperes of current.

The servos can either be powered by internal power, or by the external servo power connector. To run them off of external power, remove the internal servo power jumper like shown below. Then connect a second power supply to the “External Servo Power Connector”. To run off of internal power, connect the “Internal Servo Power” jumper and disconnect any external servo power.

Warning: powering the servos from internal power means that if the servos require more current than is available to power both servos and the processor, then the processor may reset or fail to operate at all. Running three or more servos off of internal power will likely not succeed.

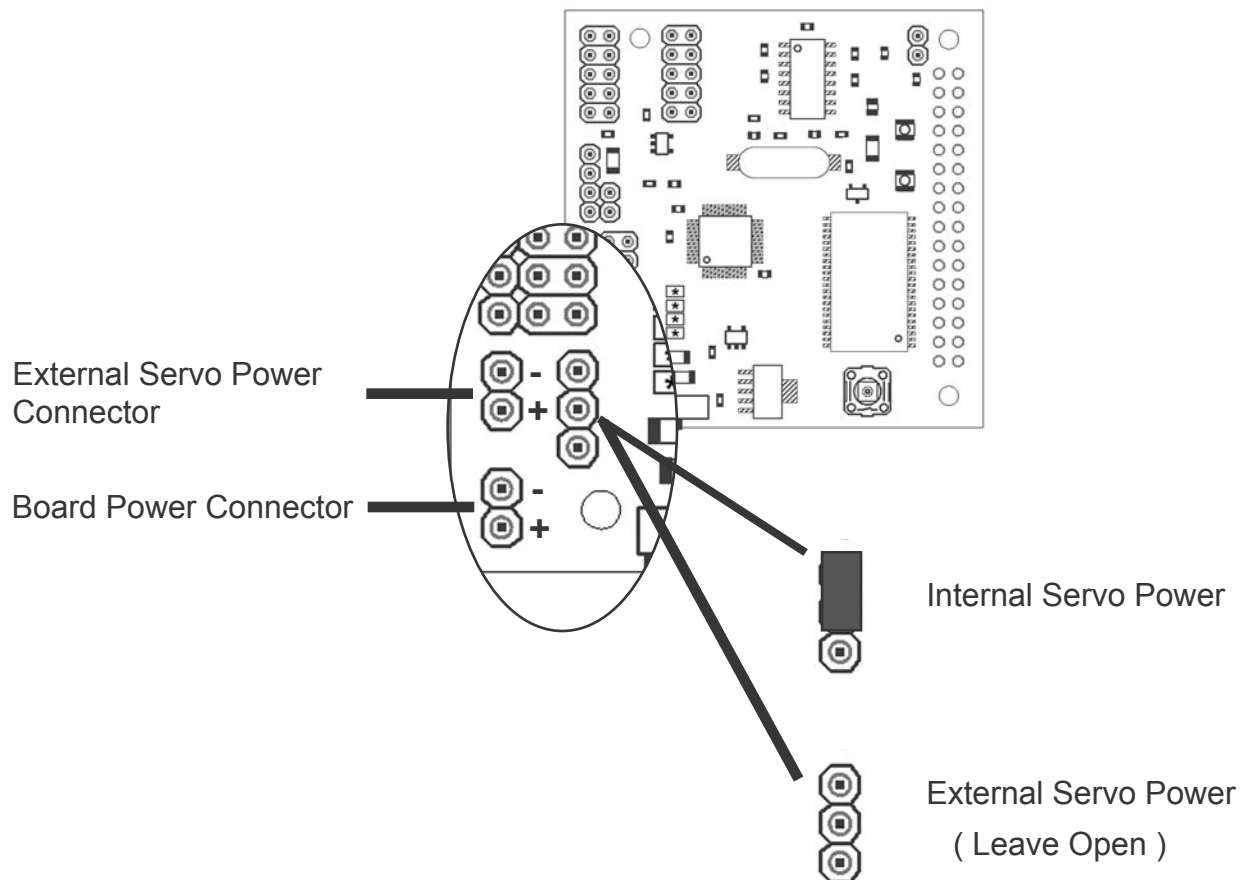

Serial Port

The CMUcam3 has a standard level shifted serial port to talk to a computer as well as a TTL serial port for talking to a microcontroller. The level shifted serial port only uses 3 of the 10 pins. It is in a 2x5 pin configuration that fits a standard 9 pin ribbon cable clip-on serial sockets and 10 pin female clip on serial headers that can both attach to a 10 wire ribbon cable. If this initially does not work, try flipping the direction that the ribbon cable connects to the CMUcam2 board. Make sure the serial jumper is in place when you use this mode. The TTL connector can be used to talk to a microcontroller without the use of a level shifting chip. The TTL pins output between 0 and 3.3volts, but are 5 volt tolerant for input. Remove the Serial Jumper when you use this mode.

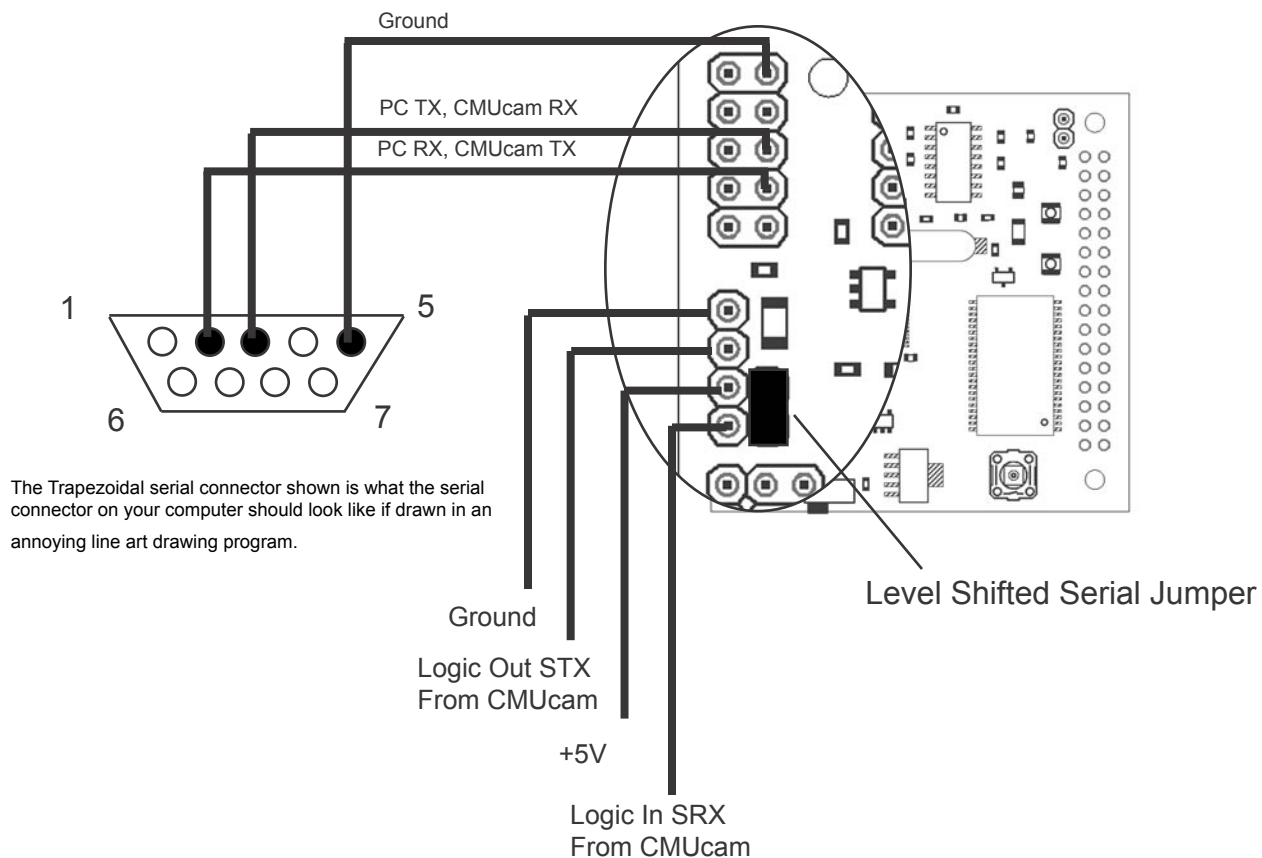

Camera Bus

This bus interfaces with the CMOS camera chip. The CMOS camera board is mounted parallel to the processing part of the board and connects starting at pin 1. The female camera header should be soldered on the back of the main CMUcam3 board.

The CMUcam3 currently works with the OV6620 and OV7630 camera modules.

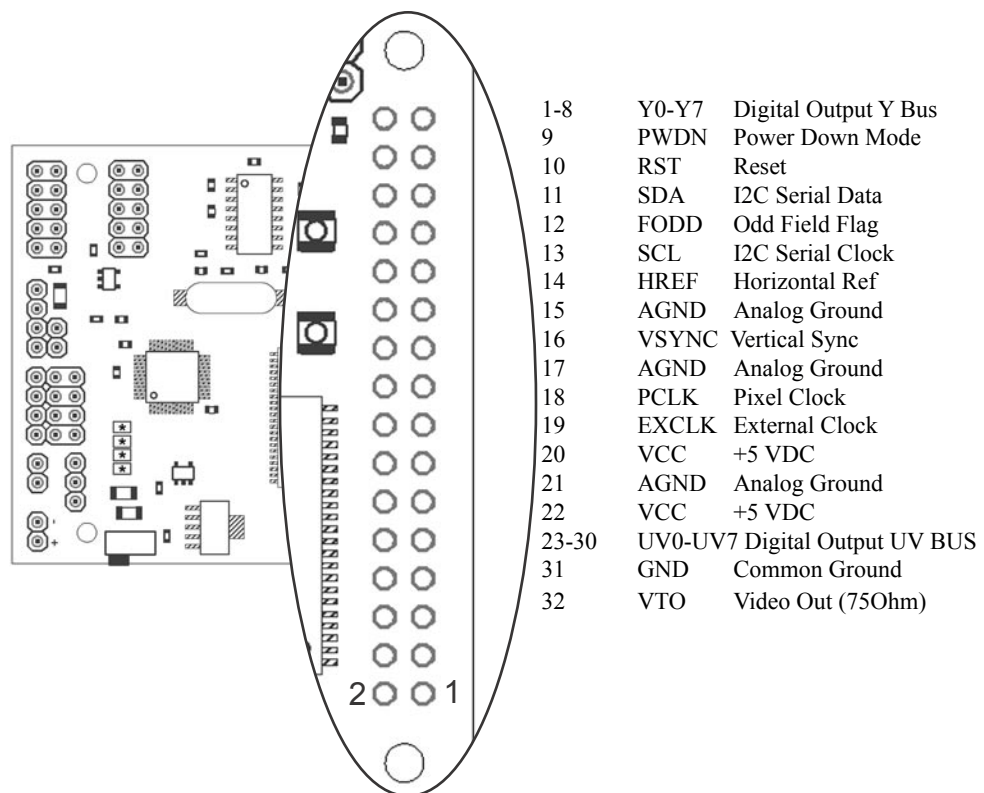

Servo Port

The CMUcam3 has the ability to control 4 servos. This can be useful if you do not wish to use a separate servo controller. The servo port can also be used as a general purpose digital outputs.

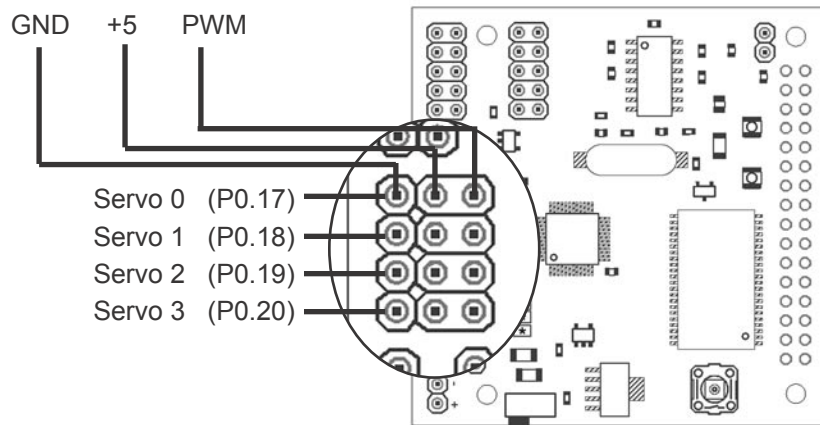

Expansion Port GPIO

The general purpose I/O header allows access to the second UART, various power control pins and the SPI pins.

Power Enable - When pulled low, the main CMUcam3 regulator is disabled causing the board to draw less than 0.01uA. All devices are shutoff and lose all active state information. When the line is released or pulled high, the board will reboot. By default, the pin is internally pulled high.

AUX Power - This pin can be configured to either externally power the board, or power an expansion board. By default, the pin is connected to the 3.3volt internal supply. By removing resistor R11 and adding a jumper resistor in place of R6, the pin is connected to the main power before the 5 volt regulator.

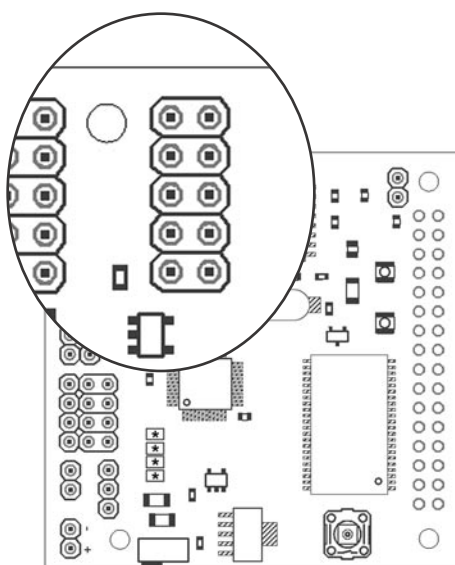
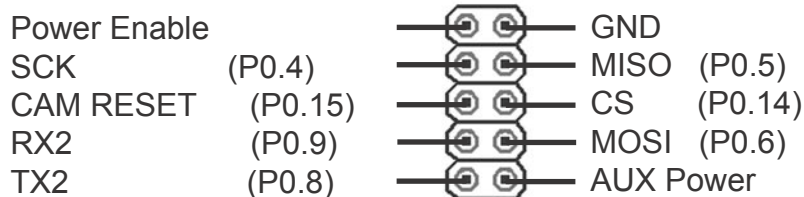

CAM RESET - This pin can be used as external I/O if the camera state is not required. Normally this pin resets the camera module and should not be used.

TX2 - The transmit pin on UART2 is not level shifted and hence can not be directly connected to a PC or none TTL external device. This pin can also be used as GPIO.

RX2 - The receive pin on UART2 is not level shifted and hence can not be directly connected to a PC or none TTL external device. This pin can also be used as GPIO.

CS - On reboot, if this pin is held low, the LPC2106 will enter bootstrap mode. Reboot can be externally induced by pulsing the power enable pin. Normally this pin will be controlled by the MMC driver. This pin can also be used as GPIO or as the SPI chip select when an MMC card is not inserted.

MOSI - Normally this pin is controlled by the MMC driver. This pin can also be used as GPIO or as an SPI output when an MMC card is not inserted.

MISO - Normally this pin is controlled by the MMC driver. This pin can also be used as GPIO or as an SPI input when an MMC card is not inserted.

SCK - Normally this pin is controlled by the MMC driver. This pin can also be used as GPIO or as the SPI clock pin when an MMC card is not inserted.

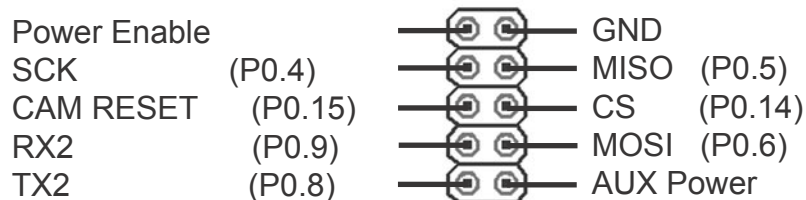

Analog Output Port

Using the OV6620 camera module, you will be able to get a PAL video signal from the analog port of the CMUcam3. This would sync up with any PAL monitor, but will not work with a standard NTSC monitor. The OV7620 camera module will output a standard black and white NTSC video signal.

To use this output, it is necessary to keep the camera at its maximum frame rate (the default) and switch it into YCrCb mode in order to see the image on a monitor.

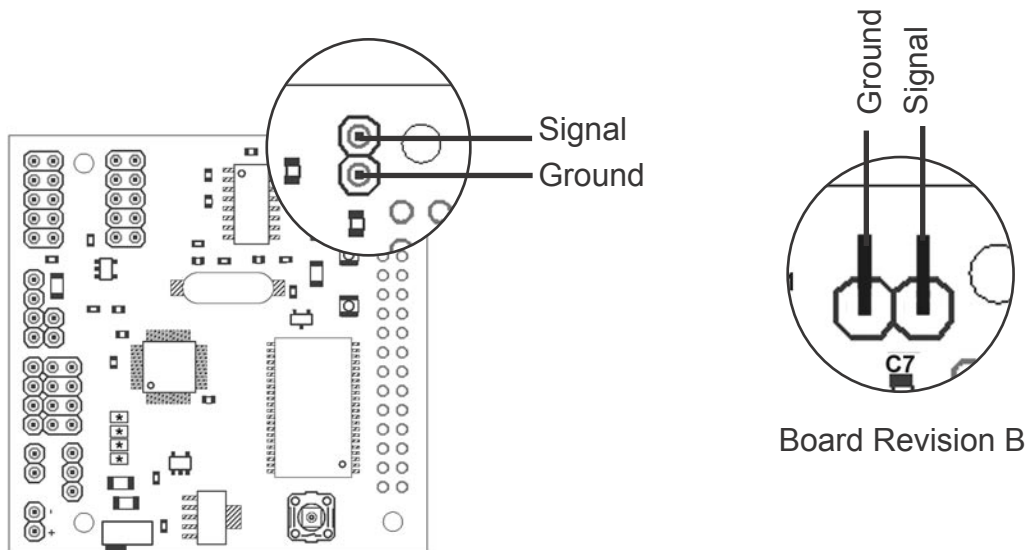

LEDs

LED 0 - This pin is shared with the MOSI pin and should be used only when CS is disabled while an MMC card is inserted.

LED 1 - This pin is shared with the Servo 2 pin. When using Servo 2, the LED will flash.

LED 2 - This pin is shared with the Servo 3 pin. When using Servo 3, the LED will flash.

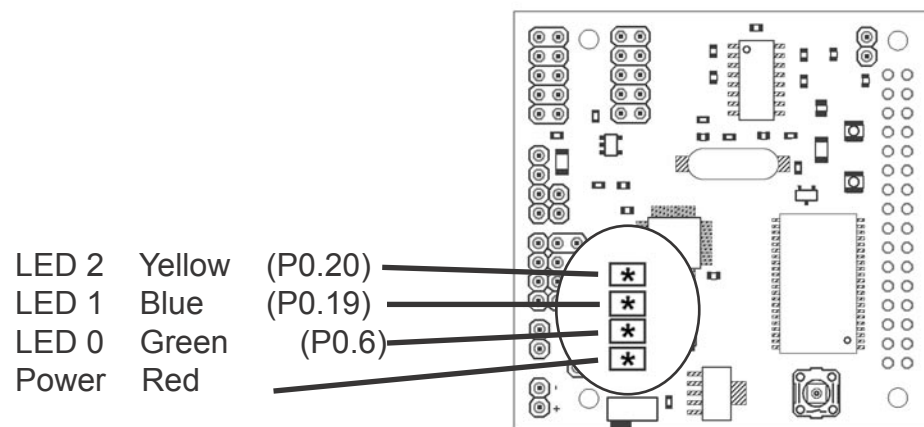

ISP Button

When held down on power up, the ISP button will enable the built in LPC2106 bootloader. After the processor has started up, the button can be read as normal GPIO. It is internally pulled high, and set low when depressed. The button shares the CS pin (P0.14) with the MMC. When using the MMC, CS is active low and hence the button cannot adversely affect data transfers.

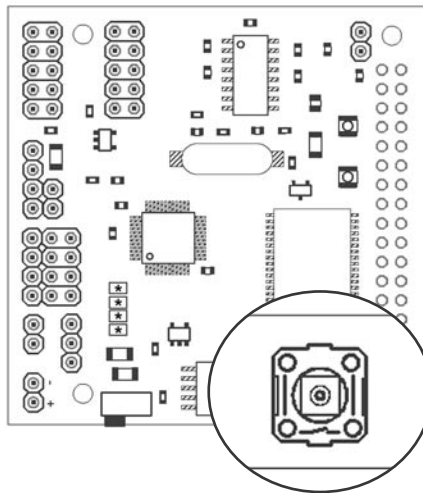

4. HARDWARE CHARACTERISTICS

Power State	Active Current	Idle Current	Voltage
All Active	130mA	25mA	5 V
External Regulator Disabled	n/a	0.01uA	n/a
CPU (@60Mhz)	30mA	10uA	1.8 V
CPU Peripherals	30	10uA	3.3 V
CMOS camera	25mA	10uA	5 V
MAX232	8mA	n/a	3.3 V
FIFO	52mA	14mA	3.3 V
MMC card	4mA	4mA	3.3 V
misc	10mA	10mA	3.3 V

Table 1: Power consumption information for various components.

Component		Description
CPU		
	RAM	64KB
	ROM	128KB (8KB taken by bootloader)
	frequency	(14-60 Mhz)
FIFO		
	Capacity	1MB
	max rate	50 FPS
CMOS camera		
	max resolution	352x288
	color depth	8bits per pixel
Misc		
	max serial rate	115,200 bits per second
	full resolution image load and pixel touch rate	26 FPS
	servo frequency	50 Hz

Table 2: CMUcam3 Characteristics

5. INSTALLING FIRMWARE

The CMUcam3 can be loaded with various firmware images. These images may perform different specific tasks. For example, the “cmucam2.hex” file will allow your CMUcam3 to emulate the functionality of the CMUcam2. When you develop your own CMUcam3 applications or would like to experiment with new firmware images, it will be necessary to flash the microprocessor. Flashing the microprocessor can be done over a standard serial port using a downloading utility. These utilities are freely available for both Windows and Unix users. The next sections show step by step how to install a new firmware image onto your CMUcam3.

Windows

1) The first step is to download and install a flash utility program. The “Philips LPC210x FLASH Utility” can be obtained from either the CMUcam (<http://www.cmucam.org>) or the Philips website.

http://www.semiconductors.philips.com/files/markets/microcontrollers/philips_flash_utility.zip

2) Double Click on the “philips_flash_utility.zip” icon.

3) Next Double Click on “setup.exe”

4) Click “Ok”

5) Click on the icon of the computer to continue the installation.



6) Once the Flash Utility is installed, connect the CMUcam3 to your serial port as shown below

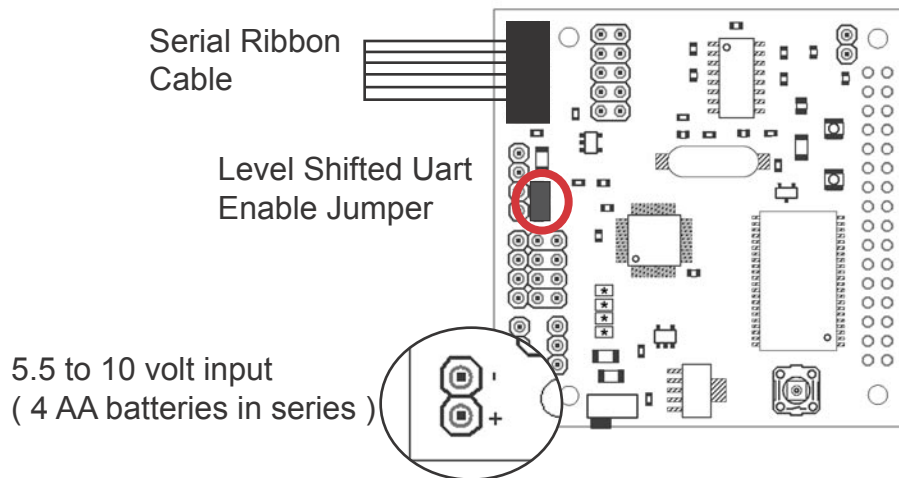

6) Go to the Start Menu, “All Programs”, “LPC210x ISP” and execute the “LPC210x ISP” application. You should eventually see a screen similar to this:

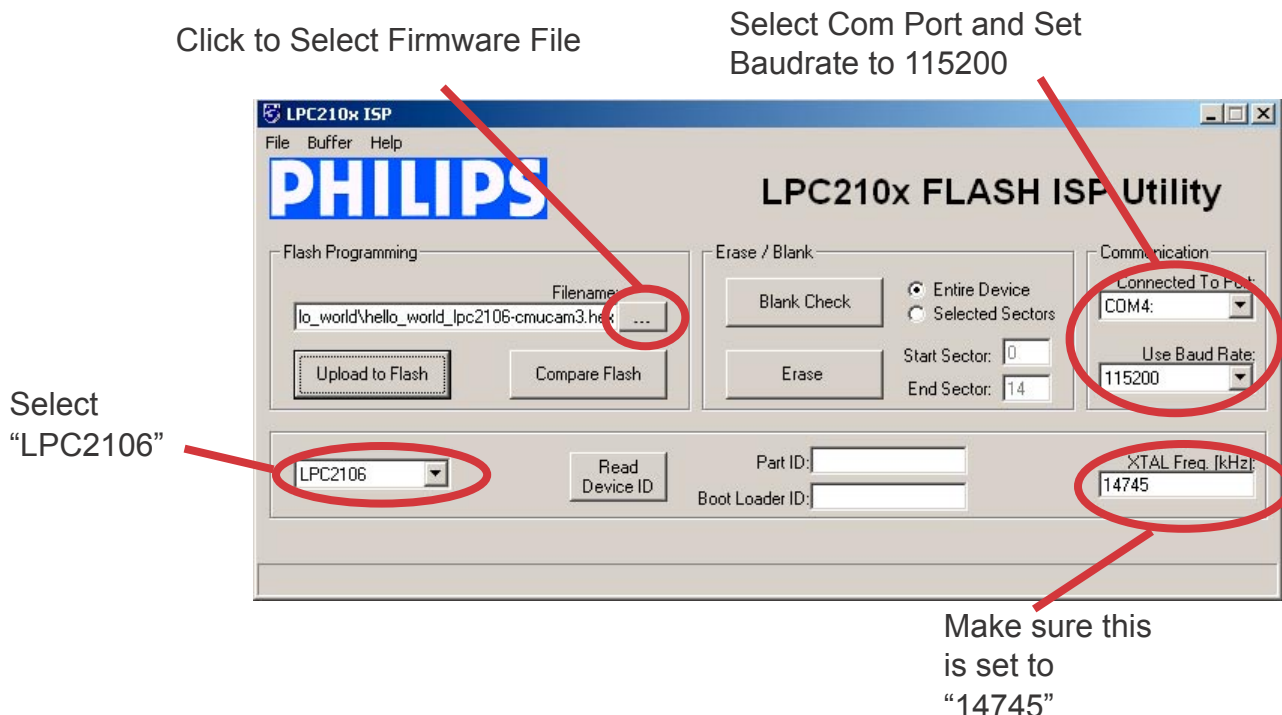

7) Click on the “...” box next to “Filename” to select a hex file to download. As an example, select the “hello_world_lpc2106-cmucam3.hex” file located in the CMUcam3 hello_world project directory. Set the correct Comm Port and Device Selections.

8) Click on the “Upload to Flash” button. You should see a dialog box like below.

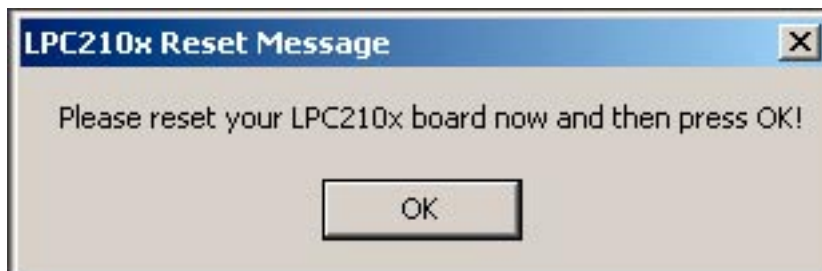

9) While holding down the “ISP” button on the camera, turn on the camera power. Make sure the button is held in for about a second. If the camera is already on, turn it off and on again while holding in the “ISP” button. If the button is depressed upon startup, the camera will enter its bootloader mode.

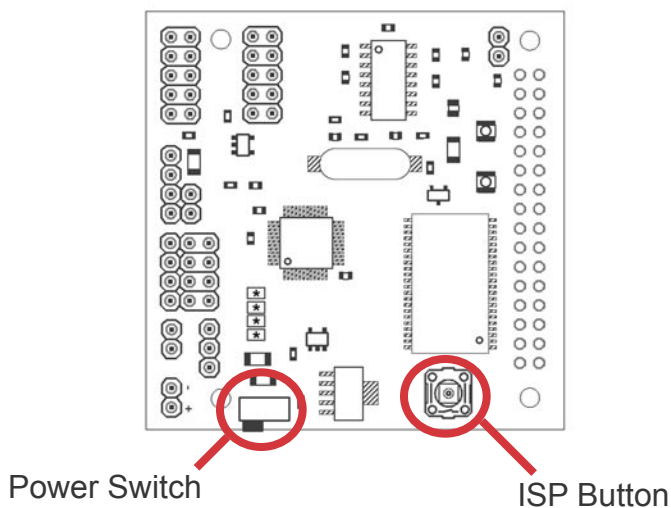

10) Press “OK” and wait for the image to download. If it fails check the connectors, reset the power and try again. The Flash Utility will say “File Upload Successfully Completed!” when the download is complete.

Linux

In order to download to the board using linux, you must make sure you have proper access rights to the serial port. You can download a flash utility program from here:

<http://guest.engelschall.com/~martin/lpc21xx/isp/>

or

<http://www.cmucam.org/wiki/Downloads>

Install lpc21isp:

- 1) unzip lpc21isp_unix.zip
- 2) cd lpc21isp_unix
- 3) make
- 4) Add the directory with lpc21isp to your path

Follow the procedure outlines in the Windows section for putting the board into its bootloader mode by holding down the ISP button while resetting power to the board.

Once installed, here is a set of sample command line argument for downloading:

```
>: cd CMUcam3/projects/hello_world
```

```
>: lpc21isp hello_world_lpc2106-cmucam3.hex /dev/ttyS0 115200 14745
```

Test the Firmware:

- 1) Open up a terminal program
- 2) Power Cycle Board

A Green Power LED should turn on. If the code is running correctly, the red LED will turn off and the blue and yellow LEDs will dimly illuminate

- 3) Make sure the board prints a startup message

- Open Minicom or some other terminal program
- Configure Minicom to be 115200 baud, 8N1, no hardware flow control / or handshaking
- Restart the board and wait 5 seconds
- You should see the following:

```
CMUcam2 v1.00 c6
:
```

- Try typing "gv" followed by enter to see if two-way serial communication is working correctly. The camera should respond.

6. ASSEMBLY INFORMATION

Top Placement (Rev. A)

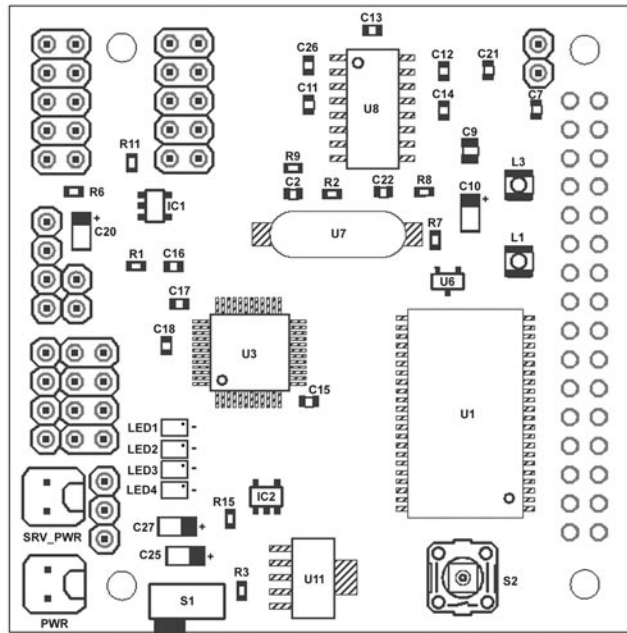

Bottom Placement (Rev. A)

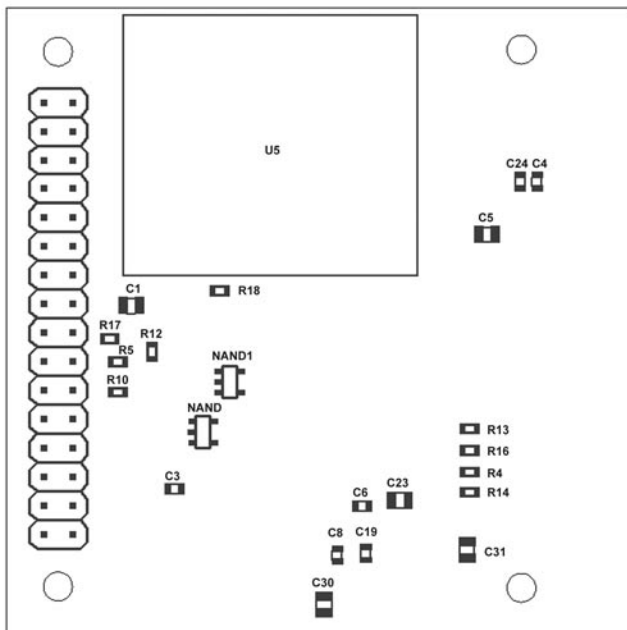

Note: Camera Bus Header on Bottom of Board.

Embedded Vision Processor

CMUcam3

Bill of Materials

Part	Value	Device	Package	Description	Part	Value	Device	Package	Description
C1	10uF	C-EUC0805	C0805	CAPACITOR	LED1	yellow	0604_LED	0805	LED
C2	33pF	C-EUC0603	C0603	CAPACITOR	LED2	blue	0604_LED	0805	LED
C3	.1uF	C-EUC0603	C0603	CAPACITOR	LED3	red	0604_LED	0805	LED
C4	1uF	C-EUC0603	C0603	CAPACITOR	LED4	green	0604_LED	0805	LED
C5	4.7uF	C-EUC0805	C0805	CAPACITOR	L1	1uH	L-USL2825P	L2825P	INDUCTOR
C6	1uF	C-EUC0603	C0603	CAPACITOR	L3	1uH	L-USL2825P	L2825P	INDUCTOR
C7	.1uF	C-EUC0603	C0603	CAPACITOR					
C8*	.01uF	C-EUC0603	C0603	CAPACITOR	NAND	SN74AHC	SN74AHC1	SOT-23-5	
C9	22uF	C-EUC0805	C0805	CAPACITOR	NAND1	SN74AHC	SN74AHC1	SOT-23-5	
C10	33uF	C-EUC1206	C1206	CAPACITOR	IC1	3.3v		SOT23-5	VREG 3.3v
C11	1uF	C-EUC0603	C0603	CAPACITOR	IC2	1.8v		SOT23-5	VREG 1.8v
C12	1uF	C-EUC0603	C0603	CAPACITOR	U1	AL440B		TSOP44	Averlogic AL440B FIFO
C13	1uF	C-EUC0603	C0603	CAPACITOR	U3	LPC2106	LPC2106	LQFP48	
C14	1uF	C-EUC0603	C0603	CAPACITOR	U5	SD/MMC	SD/MMC	CCM05-5761	
C15	.1uF	C-EUC0603	C0603	CAPACITOR	U6	MCP809	MCP809	SOT-23	
C16	.1uF	C-EUC0603	C0603	CAPACITOR	U7	CSM-7	CSM-7	CSM-7	
C17	.1uF	C-EUC0603	C0603	CAPACITOR	U8	MAX232D	MAX232D	PSOP_14_SLIM	
C18	.1uF	C-EUC0603	C0603	CAPACITOR	U11	5V Reg	REG104	SOT223-5	
C19	.1uF	C-EUC0603	C0603	CAPACITOR					
C20	33uF	C-EUC1206	C1206	CAPACITOR	S1	M251	M251	SLIDING SWITCH	
C21	.1uF	C-EUC0603	C0603	CAPACITOR	S2	10-XX	B3F-10XX	OMRON BUTTON	
C22	33pF	C-EUC0603	C0603	CAPACITOR					
C23	4.7uF	C-EUC0805	C0805	CAPACITOR	CAMERA_BUS		PINHD-2X16	2X16	PIN HEADER
C24*	.01uF	C-EUC0603	C0603	CAPACITOR	RS232_BYPASS		PINHD-1X2	1X02	PIN HEADER
C25	33uF	C-EUC1206	C1206	CAPACITOR	JP1		PINHD-1X4	1X04	PIN HEADER
C26	1uF	C-EUC0603	C0603	CAPACITOR	JP2		PINHD-2X4	2X04	PIN HEADER
C27	15uF	C-EUC1206	C1206	CAPACITOR	JP3		PINHD-2X5	2X05	PIN HEADER
C30	.01uF	C-EUC0805	C0805	CAPACITOR	JP4		PINHD-1X3	1X03	PIN HEADER
C31	.1uF	C-EUC0805	C0805	CAPACITOR	PWR		PINHD-1X2	1X02	PIN HEADER
					SRV_PWR		PINHD-1X2	1X02	PIN HEADER
R1	47K	R-US_R0603	R0603	RESISTOR	TTL_1		PINHD-1X4	1X04	PIN HEADER
R2	1M	R-US_R0603	R0603	RESISTOR	UART_0		PINHD-2X5	2X05	PIN HEADER
R3	4.7K	R-US_R0603	R0603	RESISTOR	AN_OUT		PINHD-1X2	1X02	PIN HEADER
R4	470	R-US_R0603	R0603	RESISTOR					
R5	4.7K	R-US_R0603	R0603	RESISTOR					
R6	0	R-US_R0603	R0603	RESISTOR					
R7	100K	R-US_R0603	R0603	RESISTOR					
R8	4.7K	R-US_R0603	R0603	RESISTOR					
R9	4.7K	R-US_R0603	R0603	RESISTOR					
R10	4.7K	R-US_R0603	R0603	RESISTOR					
R11**	0 (alt.)	R-US_R0603	R0603	RESISTOR					
R12	10	R-US_R0603	R0603	RESISTOR					
R13	220	R-US_R0603	R0603	RESISTOR					
R14	1K	R-US_R0603	R0603	RESISTOR					
R15	4.7K	R-US_R0603	R0603	RESISTOR					
R16	470	R-US_R0603	R0603	RESISTOR					
R17	4.7K	R-US_R0603	R0603	RESISTOR					
R18	4.7K	R-US_R0603	R0603	RESISTOR					

Revision B (Replace Following Components)

AN_OUT	SMD_HD-1X2	1X02	SMD HEADER
U5	SD/MMC	SD/MMC	CCM05-5777

* Do not install for TI regulators

** Do not install, alternate part for R6

Embedded Vision Processor

CMUcam3

Part Numbers

Qty	Digikey	Value	Device	Parts
2	WM4200-ND		PINHD-1X2	PWR, SRV_PWR
2	399-1091-1-ND	.01uF	C-EUC0603	C8, C24
1	PCC103BNCT-ND	.01uF	C-EUC0805	C30
8	PCC1788CT-ND	.1uF	C-EUC0603	C3, C7, C15, C16, C17, C18, C19, C21
1	PCC1812CT-ND	.1uF	C-EUC0805	C31
1	P1.0KGCT-ND	1K	R-US_R0603	R14
2	P470GCT-ND	470	R-US_R0603	R4, R16
1	P220GCT-ND	220	R-US_R0603	R13
1	P1.0MGCT-ND	1M	R-US_R0603	R2
7	PCC1787CT-ND	1uF	C-EUC0603	C11, C12, C13, C14, C26, C4, C6
2	240-2389-1-ND	40 Ohm	Ferrite Bead	L1, L3
8	P4.7KGCT-ND	4.7K	R-US_R0603	R3, R5, R8, R9, R10, R15, R17, R18
2	PCC2232CT-ND	4.7uF	C-EUC0805	C5, C23
1	P10GCT-ND	10	R-US_R0603	R12
1	PCC2233CT-ND	10uF	C-EUC0805	C1
1	511-1464-1-ND	15uF	C-EUC1206	C27
2	PCC1944CT-ND	33pF	C-EUC0603	C2, C22
1	PCC2401CT-ND	22uF	C-EUC0805	C9
3	511-1451-1-ND	33uF	C-EUC1206	C10, C20, C25
1	P47KGCT-ND	47K	R-US_R0603	R1
1	P100KGCT-ND	100K	R-US_R0603	R7
1	P0.0GCT-ND	JMPR	R-US_R0603	R6 (default) or R11
1	404-1021-1-ND	GREEN	LED	L4
1	404-1017-1-ND	RED	LED	L3
1	404-1028-1-ND	BLUE	LED	L2
1	404-1019-1-ND	YELLOW	LED	L1
1	XC1279CT-ND	14.7456	CSM-7	U7
1	296-6938-5-ND	MAX232D	MAX232D	U8
1	MCP809T-300I/TTCT-ND	MCP809/10	MCP809/10	U6
1	296-11021-1-ND	3.3V	MIC5219BM5	IC1
1	296-12520-1-ND	1.8V	MIC5219BM5	IC2
1	REG104GA-5-ND	5V Reg	REG102	U11
1	401-1732-1-ND	SD/MMC	SD/MMC	U5
2	296-1087-1-ND	SN74AH	SN74	SINGLE_NAND, SINGLE_NAND1
1	A26525-40-ND	Dual Header		JP2, JP3, UART_0,
1	A26465-ND	Dual Row Female		*CAMERA_BUS
1	A26509-40-ND	Single Header		AN_OUT, RS232_BYPASS, JP4, JP1, TTL_1
1	EG1847-ND	Switch	Sliding Switch	S1
1	SW400-ND	Push Button	Push Button	S2
1	Philips	ARM7-TDMI	LPC2106	U3
1	Averlogic	FIFO	AL4V8M440	U1

Revision B (Replace Following Components)

1	S1113E-36-ND	SMD RA Single Header		AN_OUT
1	401-1954-1-ND	SD/MMC	SD/MMC	U5

* CAMERA_BUS Header Soldered on Bottom Side of Board

Placement Coordinates (Revision A)

Top SMD Placement Coordinates

C2 31.23 40.47 180 33pF C0603
 C7 52.69 47.88 270 .1uF C0603
 C9 46.86 44.25 90 22uF C0805
 C10 46.84 38.76 270 33uF C1206
 C11 32.60 48.30 90 1uF C0603
 C12 44.53 51.30 90 1uF C0603
 C13 38.20 54.91 180 1uF C0603
 C14 44.51 47.80 270 1uF C0603
 C15 32.63 22.15 0 .1uF C0603
 C16 20.68 34.05 0 .1uF C0603
 C17 21.19 30.73 0 .1uF C0603
 C18 20.02 27.07 90 .1uF C0603
 C20 12.52 37.16 270 33uF C1206
 C21 48.46 51.36 90 .1uF C0603
 C22 39.20 40.64 180 33pF C0603
 C25 21.69 8.46 180 33uF C1206
 C26 32.57 51.80 90 1uF C0603
 C27 20.98 11.13 180 15uF C1206
 LED1 20.73 16.18 0 404-1021-1-ND 0805
 LED2 20.70 14.35 0 404-1021-1-ND 0805
 LED3 20.70 19.89 0 404-1021-1-ND 0805
 LED4 20.70 17.98 0 404-1021-1-ND 0805
 IC1 19.02 39.38 270 MIC5219BM5 SOT23-5
 IC2 28.88 13.73 0 MIC5219BM5 SOT23-5
 L1 51.16 34.49 90 1uH L2825P
 L3 51.16 41.25 90 1uH L2825P
 R1 17.36 34.05 180 47K R0603
 R2 34.70 40.44 180 1M R0603
 R3 26.56 5.51 270 4.7K R0603
 R6 11.89 40.64 0 JMPR R0603
 R7 43.78 36.34 270 100K R0603
 R8 42.80 40.61 0 4.7K R0603
 R9 31.23 42.74 180 4.7K R0603
 R11 16.99 43.18 90 JMPR R0603
 R15 25.68 11.76 270 4.7K R0603
 U1 46.47 21.07 90 TSOP44
 U3 27.40 26.42 0 LPC2106 LQFP48
 U6 44.90 32.73 180 MCP809/10 SOT-23
 U7 34.92 36.81 0 CSM-7 CSM-7
 U8 38.23 48.01 270 MAX232D PSOP_14_SLIM
 U11 32.99 6.60 270 REG102 SOT223-5

Bottom SMD Placement Coordinates

C1 50.54 30.78 0 10uF C0805
 C3 46.70 14.64 0 .1uF C0603
 C4 14.72 41.70 270 1.0uF C0603
 C5 19.14 37.07 0 4.7uF C0805
 C6 30.17 13.13 180 1.0uF C0603
 C8 32.35 8.78 90 .01uF C0603
 C19 29.83 8.94 90 .1uF C0603
 C23 26.83 13.63 180 4.7uF C0805
 C24 16.22 41.70 270 .01uF C0603
 C30 33.50 4.42 90 .01uF C0805
 C31 20.90 9.22 90 .1uF C0805
 R4 20.65 16.13 0 1K R0603
 R5 51.70 25.81 0 4.7K R0603
 R10 51.70 23.16 0 4.7K R0603
 R12 48.70 26.73 270 10 R0603
 R13 20.65 19.91 0 1K R0603
 R14 20.65 14.30 0 1K R0603
 R16 20.65 18.01 0 1K R0603
 R17 52.43 27.84 180 4.7K R0603
 R18 42.70 32.08 0 4.7K R0603
 NAND 44.22 19.61 270 SN74AHC SOT-23-5
 NAND1 41.85 24.01 270 SN74AHC SOT-23-5
 U5 38.62 41.59 270 SD/MMC CCM05-5761

Placement Coordinates (Revision B)

Top SMD Placement Coordinates

AN_OUT 51.94 52.07 90 2_SMT_RA_HEADER
 C2 31.23 40.65 180 33pF C0603
 C7 52.69 46.46 270 .1uF C0603
 C9 46.51 44.25 90 22uF C0805
 C10 46.48 38.94 270 33uF C1206
 C11 32.60 48.30 90 1uF C0603
 C12 44.53 51.30 90 1uF C0603
 C13 38.20 54.91 180 1uF C0603
 C14 44.51 47.80 270 1uF C0603
 C15 32.63 22.15 0 .1uF C0603
 C16 20.68 34.05 0 .1uF C0603
 C17 21.19 30.73 0 .1uF C0603
 C18 20.02 27.07 90 .1uF C0603
 C20 12.52 37.16 270 33uF C1206
 C21 47.93 51.36 90 .1uF C0603
 C22 39.56 40.64 180 33pF C0603
 C25 21.69 8.46 180 33uF C1206
 C26 32.57 51.80 90 1uF C0603
 C27 20.98 11.13 180 15uF C1206
 LED1 20.73 16.18 0 404-1021-1-ND 0805
 LED2 20.70 14.35 0 404-1021-1-ND 0805
 LED3 20.70 19.89 0 404-1021-1-ND 0805
 LED4 20.70 17.98 0 404-1021-1-ND 0805
 IC1 19.02 39.38 270 MIC5219BM5 SOT23-5
 IC2 28.88 13.73 0 MIC5219BM5 SOT23-5
 L1 51.16 34.49 90 1uH L2825P
 L3 52.58 41.25 90 1uH L2825P
 R1 17.36 34.05 180 47K R0603
 R2 34.70 40.62 180 1M R0603
 R3 26.56 5.51 270 4.7K R0603
 R6 11.89 40.64 0 JMPR R0603
 R7 43.78 36.34 270 100K R0603
 R8 42.80 40.61 0 4.7K R0603
 R9 32.61 44.87 90 4.7K R0603
 R11 16.99 43.18 90 JMPR R0603
 R15 25.68 11.76 270 4.7K R0603
 U1 46.47 21.07 90 TSOP44
 U3 27.40 26.42 0 LPC2106 LQFP48
 U6 44.90 32.73 180 MCP809/10 SOT-23
 U7 34.92 37.34 0 CSM-7 CSM-7
 U8 38.23 48.01 270 MAX232D PSOP_14_SLIM
 U11 32.99 6.60 270 REG102 SOT223-5

Bottom SMD Placement Coordinates

C1 50.54 30.78 0 10uF C0805
 C3 46.70 14.64 0 .1uF C0603
 C4 14.72 41.70 270 1.0uF C0603
 C5 19.14 37.07 0 4.7uF C0805
 C6 30.17 13.13 180 1.0uF C0603
 C8 32.35 8.78 90 .01uF C0603
 C19 29.83 8.94 90 .1uF C0603
 C23 26.83 13.63 180 4.7uF C0805
 C24 16.22 41.70 270 .01uF C0603
 C30 33.50 4.42 90 .01uF C0805
 C31 20.90 9.22 90 .1uF C0805
 R4 20.65 16.13 0 1K R0603
 R5 51.70 25.81 0 4.7K R0603
 R10 51.70 23.16 0 4.7K R0603
 R12 48.70 26.73 270 10 R0603
 R13 20.65 19.91 0 1K R0603
 R14 20.65 14.30 0 1K R0603
 R16 20.65 18.01 0 1K R0603
 R17 52.43 27.84 180 4.7K R0603
 R18 42.70 32.08 0 4.7K R0603
 SINGLE_NAND 44.22 19.61 270 SN74AHC SOT-23-5
 SINGLE_NAND1 41.85 24.01 270 SN74AHC SOT-23-5
 U5 40.33 46.88 180 ITT5777 ITT5777

Schematic

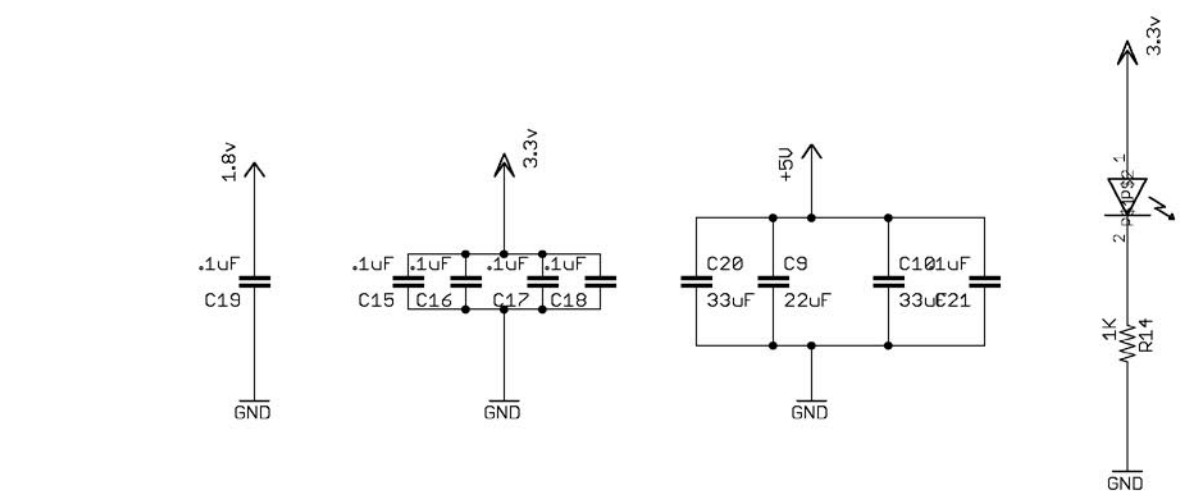
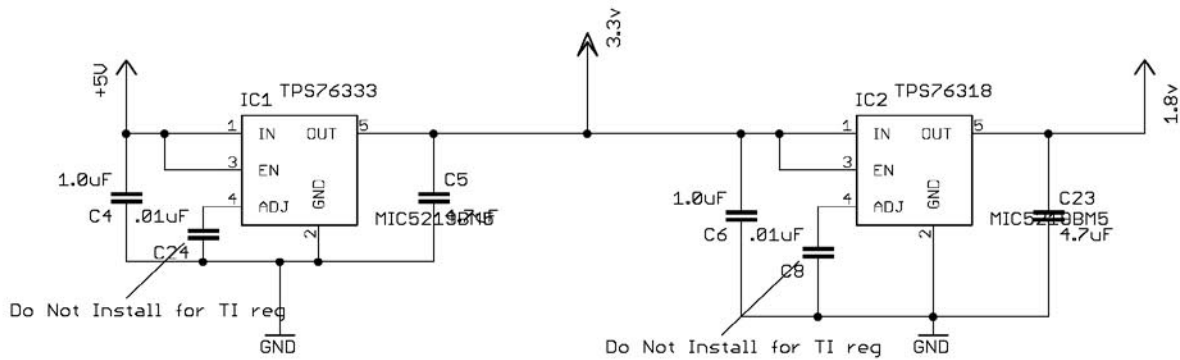
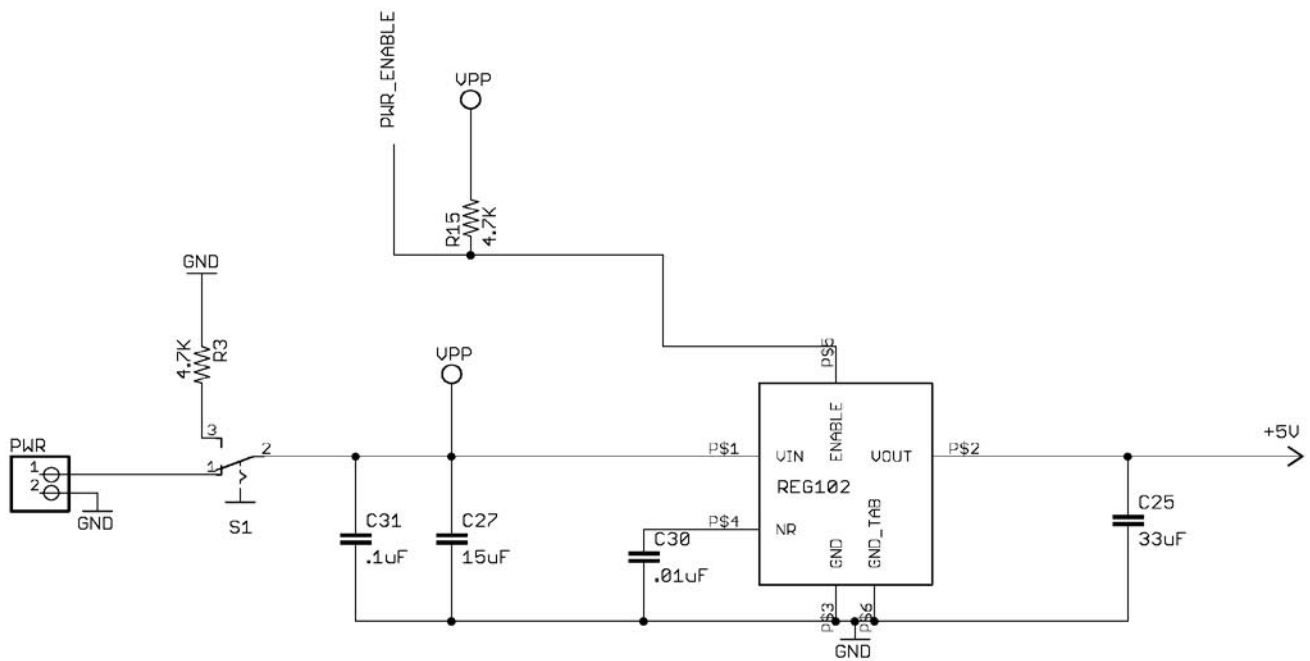

Embedded Vision Processor

CMUcam3

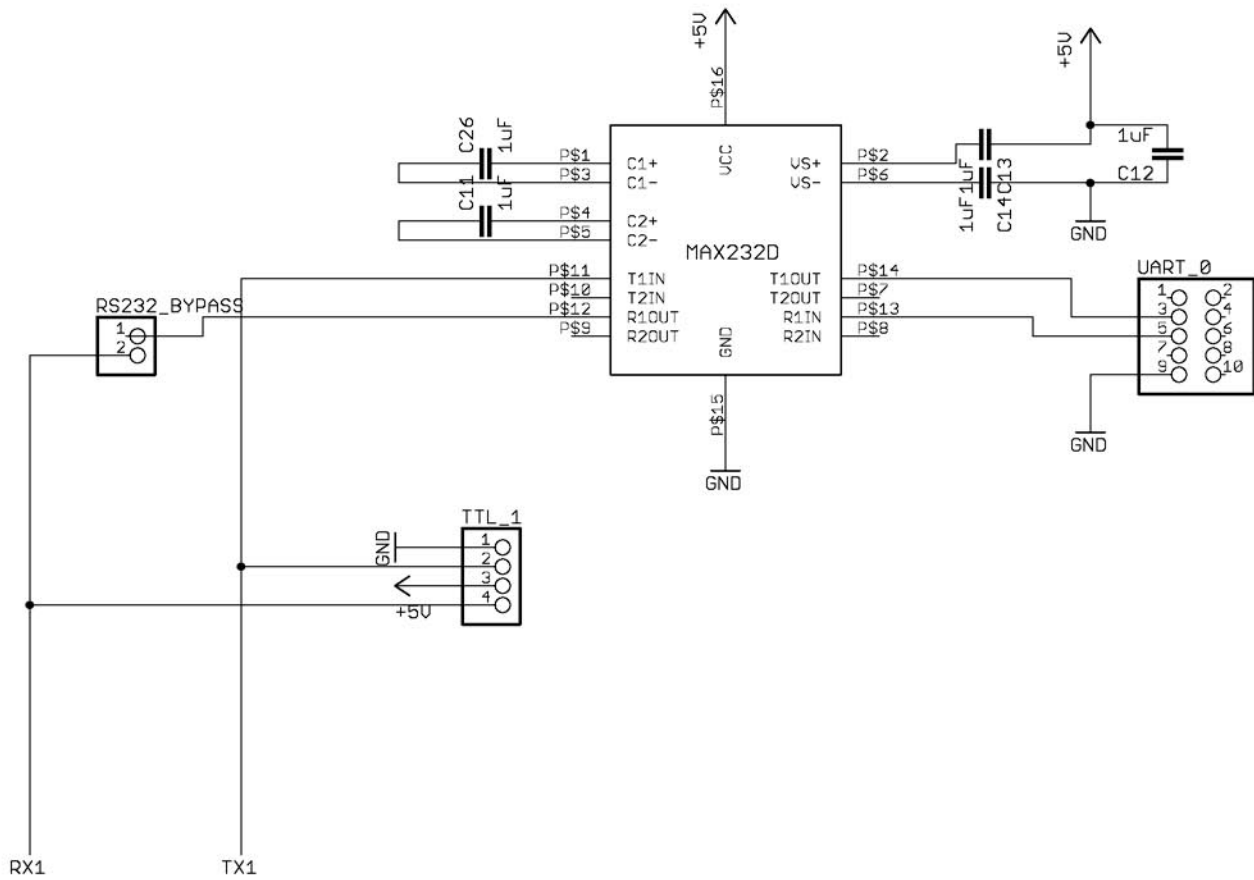
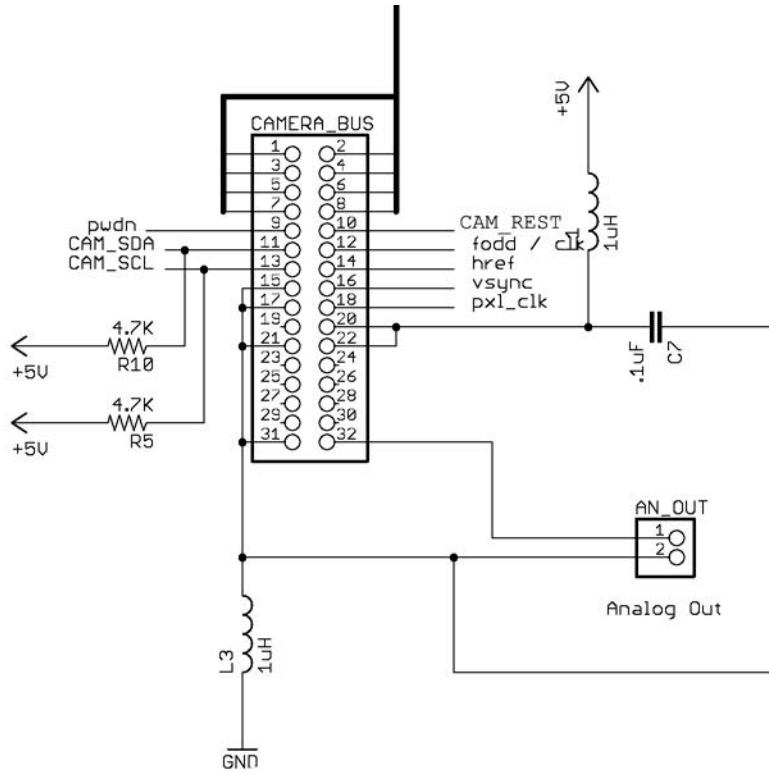

Embedded Vision Processor

CMUcam3

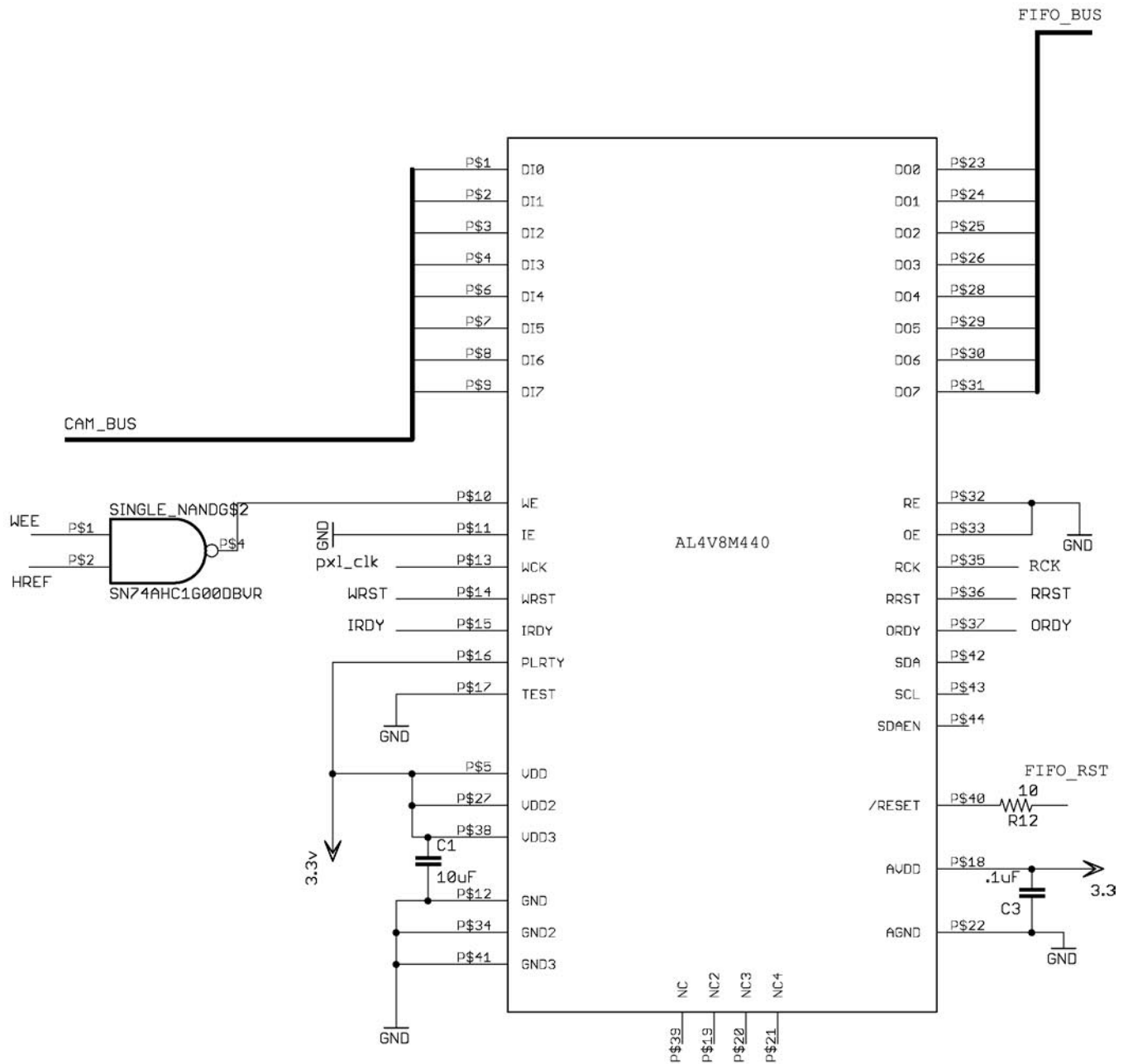

Embedded Vision Processor

CMUcam3

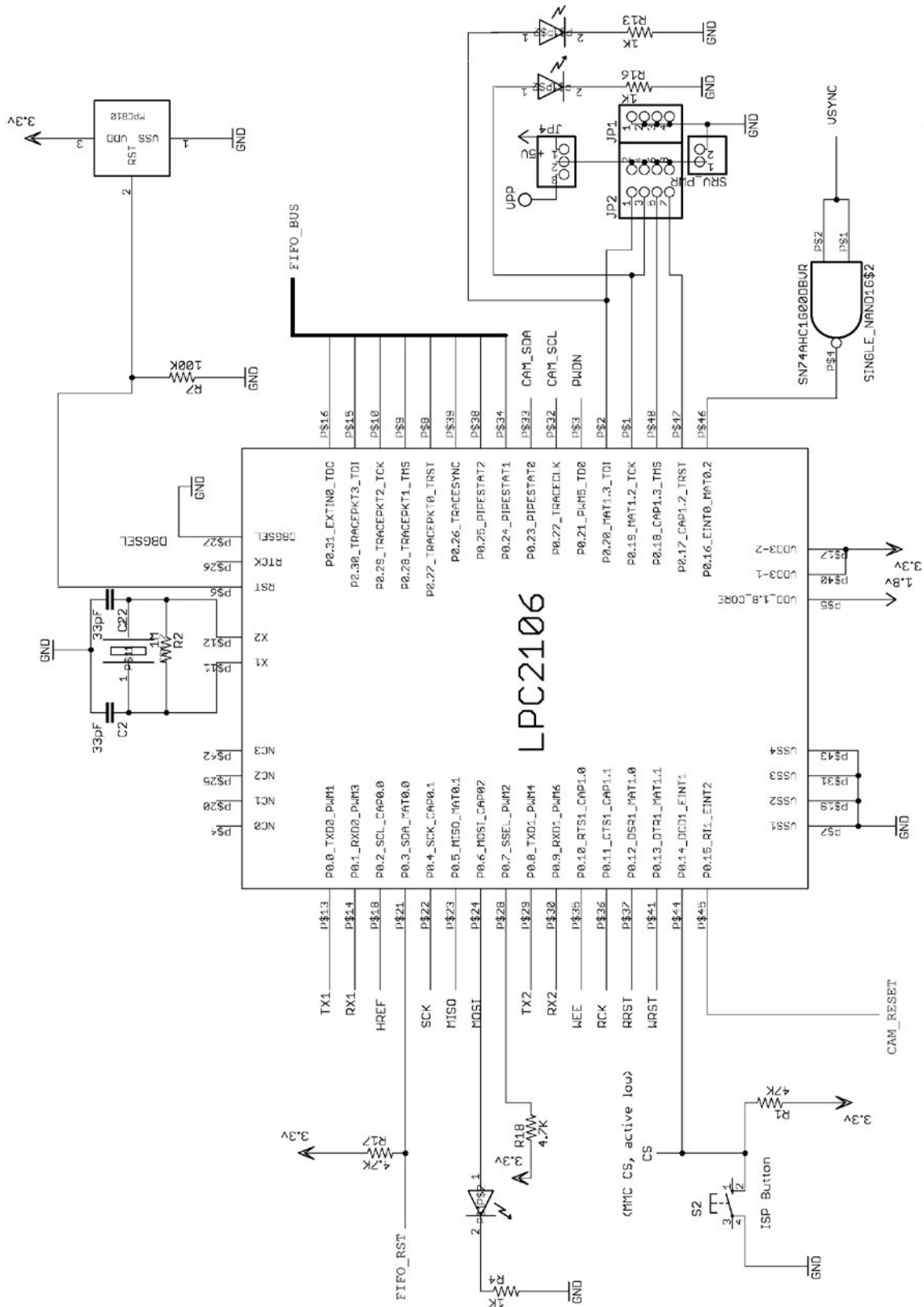

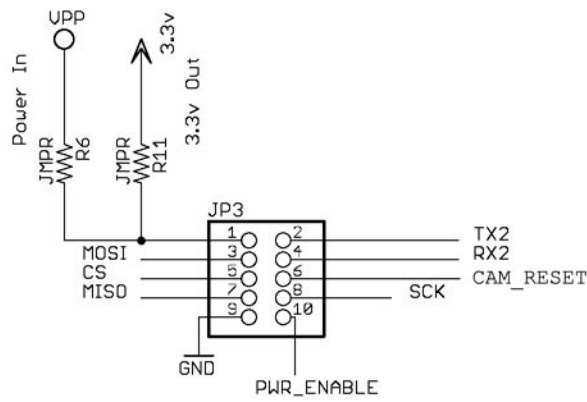
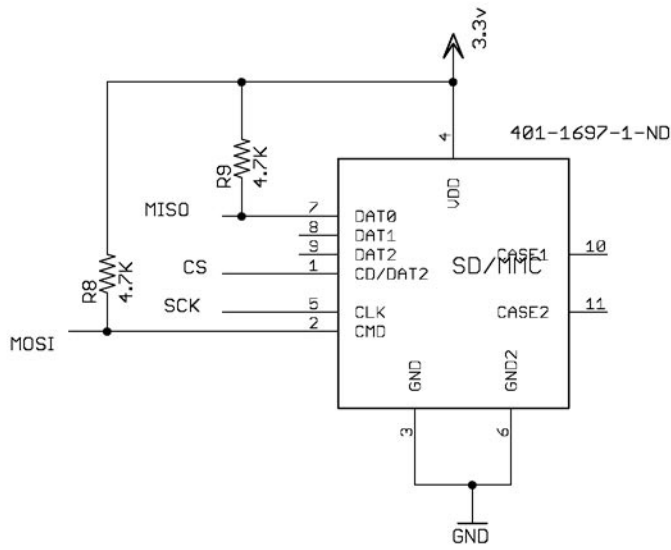

Dimensions

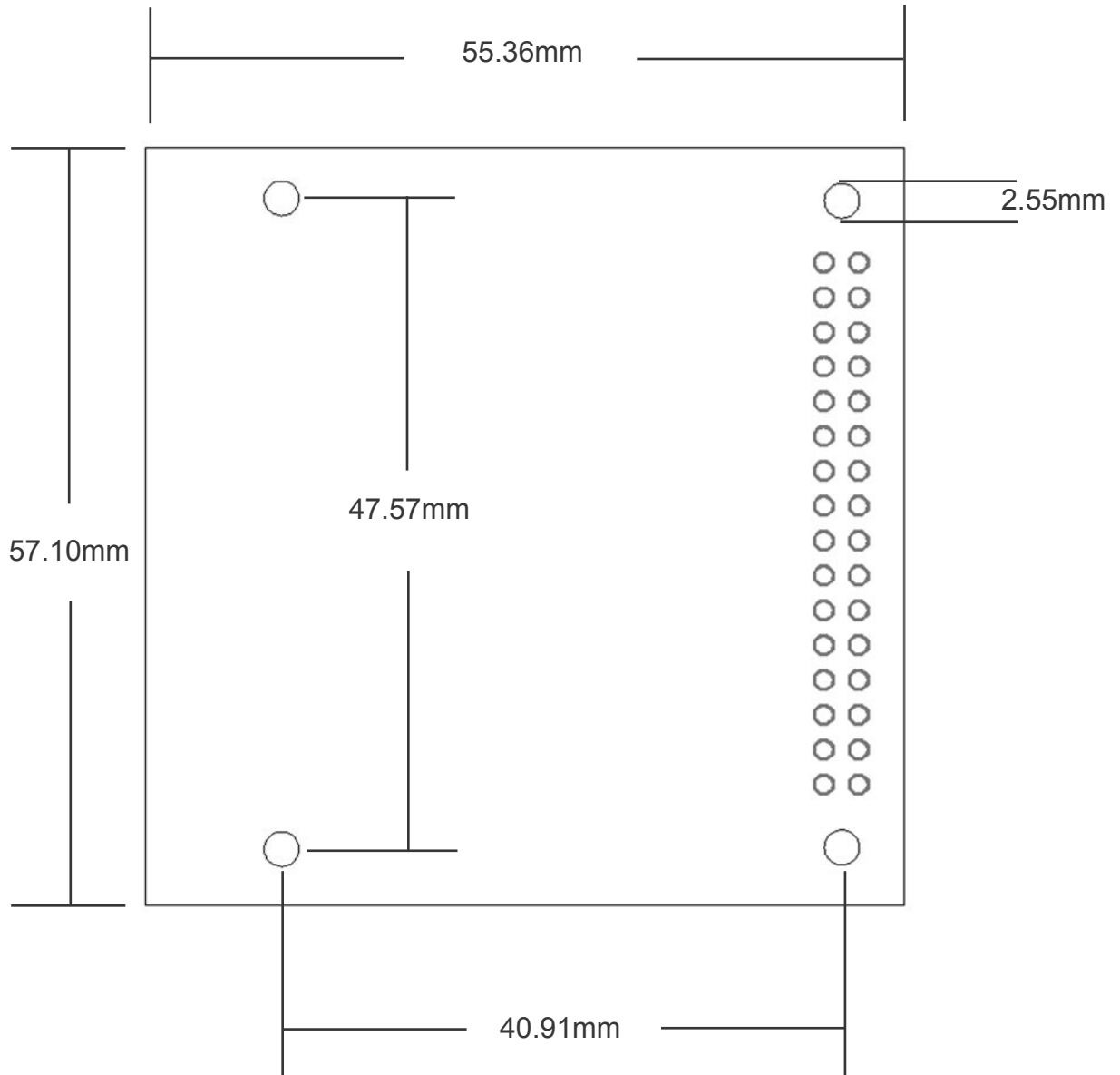

7. REVISION HISTORY

Version 1.01 August 7, 2007

- Fixed External Servo Power Connector Documentation
- Added Revision History

Version 1.02 September 22, 2007

- Fixed TTL serial pinout on page 6