

# Inside the pulsejet engine

Report 1.0

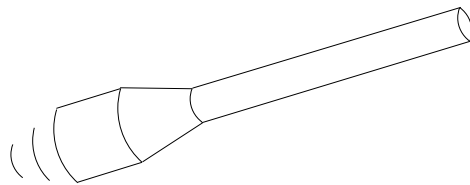

Written by  
Fredrik Westberg

This report would not exist without Dave Brill who inspired me from the beginning, thanks for all help.

Also a great thanks to those who have contributed with all kinds of information.

**This report is a private study on the pulsejet engine.**

You can contact me by e-mail,  
“fredrik\_wg@hotmail.com”

My homepage address.  
“<http://www.geocities.com/Area51/Rampart/9722/welcome.htm>”.

This document is free available on my homepage.

# Summary

This document describes how to build/design a pulsejet engine, and how to put all parts together. I have also included some F.A.Q with answers. I have put some effort into the V1 chapter which describes the No: 1 Pulsejet engine, the Argus AS-014. There are also a short briefing on the pulsejet theories, this chapter is the one I'am most uncertain about. Finally I have added some blue-prints on different pulsejet engines, including my own design.

Fredrik Westberg, 25 April 2000

# List of contents

	Page
1. <b>Introduction.</b>	4
1.1 Who I am	4
1.2 Revision history	5
1.3 The first pulsejets.	5
1.4 For what use.	5
1.5 Pulsejets in this report	6
2. <b>Pulsejet theory.</b>	7
2.1 How it works.	7
2.2 Equations.	11
2.2.1 <i>Pulsejet operation equations</i>	11
2.2.2 <i>Valve flow area</i>	12
2.2.3 <i>Exhaust pipe lenght</i>	15
2.2.4 <i>Thrust (Output power)</i>	16
2.3 Argus pulsejet (V1)	17
3. <b>Building your own pulsejet</b>	20
3.1 Some ideas. (F.A.Q)	20
3.2 My pulsejets	27
3.2.1 <i>Building description</i>	28
3.3 Future project	31
3.4 Pulsejet plans.	33
4. <b>Conclusion.</b>	37
5. <b>Glossary</b>	38
6. <b>Sources</b>	38
7. <b>Index</b>	39

## Pictures

No. 1 My ice yacht	No. 14 Angled valve design
No. 2 Heinz Ollarius plane, 90 mm pulsejet	No. 15 Pulsejet engine design
No. 3 Static pressure wave	No. 16 Pulsejet assambly
No. 4 Microwave antenna	No. 17 Start attempt on my second engine
No. 5 Valve flow area table	No. 18 Two pulsejets
No. 6 Air flow speed	No. 19 Valve plate deformation
No. 7 Tube shape	No. 20 Fuel injector
No. 8 Exhaust pipe lenght table	No. 21 Large pulsejet engine design
No. 9 Argus pulsejet engine	No. 22 Ice yacht
No. 10 Fieseler Fi 103 (V1)	No. 23 Brauner drawings
No. 11 Flower valve shape	No. 24 Alpha drawings
No. 12 Argus valve design	No. 25 My own drawing
No. 13 My own valve design	No. 26 Argus drawings

# 1. Introduction

## 1.1 Who I am

My name is Fredrik Westberg, and I'm born in April 1973, in Sweden. I am (right now) a bachelor or engineer in computer and electronic science, but my interest's lies more into the mechanic science area, like pulsejet engines and other physical things. Anyway, I do have an ordinary jobb, right now as a test engineer. My job is to make test equipment for printed circuit boards and for large systems. My employer is Solectron.

Well, I have been interested in designing, building my own things, like different kind of vehicles. The first project was a propeller driven machine, ice yacht. I used it in the winter, riding on the ice covered lakes. Maximum speed of 25-30 Km/h with a 150 cm<sup>3</sup> engine, se picutre below. Another project was a boat driven by a pushing propeller. This boat was 3x4 meter big, it had two pontoons, and an 45-50 hp engine. With my badly homemade propeller, it was no success.



**Pic No. 1 My ice yacht**

Why am I writing a paper called "Inside the pulsejet engine"? There are several things. One is my interest in pulsejet engines, I have build two engines already with a lot of experience as outcome. None of them worked well, but I think I know what I have to do with them to get them work. Second is one of my bad habits. I always want to understand everything, in detail. Third, I will learn to write better English, at least I hope so.

This document has been writen during a period of 10 month.

## 1.2 Revision history

Revision	Note
P 1.0	First Release (preliminary state)
R 1.0	New chapter 1.5
	Chapter 1.4 updated
	Chapter 2.1 updated
	Chapter 2.2.2 updated
	Chapter 2.2.4 updated
	Chapter 3.1, question 3. New valve design added

## 1.3 The first pulsejets

The word “pulse” and “engine” can be recorded back to somewhere around 1880-1890. And in the early 1900 a man in France build a pulsejet engine, but he didn't get it into a reconance, only single explosions.

Almost everybody has heard something about the “Buzz bomb”, they know where it was used, and how terrible it was. That is true. Their sound spread horror across southern England during the Second World War. This “thing” was the Fieseler Fi 103 powered with an Argus AS-014 pulsejet engine. This aircraft was an unmanned bomb, steered by a gyro. When the fuel ran out, it just dropped down from the sky and explodes on the ground. But it was something wrong with the design, the engine was never supposed to die out before impact. Because this was a warning signal, when the “Buzz bomb” stopped, soon there would be an explosion.

But the Englishmen could defend them self from this weapon. It wasn't fast enough for thier fastest aircrafts, so it was possible to hunt it and and shoot it down. It was also possible to shoot it down with anti-aircraftgun.

I will go into detail on this Argus pulsejet engine later when I discuss pulsejet theory in chapter 2.

## 1.4 For what use

Why do we need pulsejet engines? We have operational jet engines, big and small and they run longer and more efficient that any pulsejet engine. That's true, but you can't build a lightweight jet engine that's deliver 3-10 kg thrust easily in you garage. But with a pulsejet, you can.

So what do we use them for? Small engines are mainly used to give thrust to model aircrafts.

I got a mail from Gilberto Giardini Weber, he said he had worked in a factory where they produced towplanes (drones). They where also producing a model

aeroplane powered with a 17 cc engine, with a top speed of 250 Km/h. These planes were used as targets for the anti-aircraft artillery. At that time a project was initiated to develop a pulsejet engine on 50 lbs thrust for these planes. Gilberto said he left the company before anything happens. He later heard that the project was closed because the Brazilian army didn't give the funds needed to the research. But he does know that some preliminary drawings and specifications were made, anyone heard of a 50 lbs pulsejet engine? Please, e-mail me about it.

## 1.5 Pulsejets in this report

In this report I will use a few pulsejet engine designs in my investigation. Those are, Argus AS-014, Team Helmonds P90 and my own engine design.

Team Helmonds P90 have originally been designed by Heinz Ollarius, His designs are approx. 20 years old. You will find this engine described on different places.



**Pic No. 2 Heinz Ollarius plane, 90 mm pulsejet.**

Picture to the left is Heinz Ollarius model airplane, it's completely built from fiberglass and honeycomb and it's very strong and super light. The engine is a 90 mm pulsejet with 80 N thrust. Heinz worked with an injection pressure of 8 bar. Picture to the right is a starting attempt, Heinz (to the left in the picture) is managing the fuel and air pressure. Remko Klaassens (to the right) is igniting the engine. Unfortunately Heinz passed away a few years ago, he is by many seen as the "number 1" pulsejet engine designer.

Remko Klaassens is now building these engines after Jean Quadvlieg gave all his tools and equipment to him. Jean was a close friend of Heinz, he built even more engines than Heinz based on the 90 mm pulsejet engine. Jean Quadvlieg also made an engine for the Pulsejet team Helmond (AMTjets) and he is now building micro turbines with high thrust.

Remko also mentions that the jet aeroplanes need a good pilot, and one of the best is Bennie v/d Goor. He has a spectacular show and his motto is "Go low and fast" but always with safety in first place. That's what makes him the best.

Pictures and story come from Remko Klaassens.

## 2. Pulsejet Theory

### 2.1 How it works

When you look at the material details you will think, “This must be a simple engine” but in fact, it's a rather complex engine. It's also difficult to understand the operation sequence.

So where do we begin? The first guy to understand the theories was the German Paul Schmidt. He was active from 1928 to later after the Second World War with his pulsejet ideas. In fact, he did not build the famous V1 engine, he just led the Argus Company on the right track when they designed the engine. He had a better and more efficient construction. But he didn't reveal his secrets because he thought that he could make a profit out of his ideas after the war. But the turbine jet engine was at its dawn and the pulsejet engine never became the commercial success that Paul once thought.

Below is my **personal thought** about the pulsejet engine operation sequence.

#### Fact, my experience

A pulsejet engine delivers thrust, gasses of burned fuel/air come out of the exhaust pipe with such a speed that a force is created in the opposite direction.

A pulsejet engine can run without any outside help.

The pulsejet engine repeats its puls sequence at a given frequency.

The resonance frequency is among others depending on the length of the pulsejet engine.

#### Conclusion, my experience

Okey, here comes the hard part. First of all, pulsejet engine is now also related to the word “tube”.

We begin with the fact that the tube is approx. 15-20% filled with fuel/air mixture (\*), somehow it detonates and the high pressure makes the gasses to be pushed out through the exhaust pipe in a high speed, probably not above speed of sound. By reading documents and talking to other people my experience is that the peak speed may be speed of sound but not above.

I have found that there are at least two different circumstances why a pulsejet engine operates in a resonance sequence. Simply, why the pulsejet engine runs.

- The pulsejet engine has a length of a half wavelength of the resonance frequency. This means that when detonation occurs a shockwave is travelling from “valves” to the end of the pipe. Then the shockwave turns

and go back (reflection). This pressure resonance is what I call the **static pressure**.

If we compare audio resonance theory with electrical resonance theory we will find that they are pretty good adaptable. Resonance behavior is the same. Electricity is also my subject field.

If we look at the resonance in an electrical cable, we look at open, close and adapted termination. Adapted termination will return none reflection. Open and close termination will return 100% but in different phase. And in this case it's the open termination that is comparable to the pulsejet engine.

In a cable, 100% are reflected back, but in a pulsejet engine this is not the case. Imagine putting a loudspeaker where the valves are placed and tune it into the resonance frequency, should be something like  $X \cdot 2 \cdot f = 340$ , where  $X$  = pulsejet length in meter.  $f$  is the resonance frequency. Ofcourse will you here the resonance sound at the open end, so this will decrease the reflected shockwave, how much is hard to tell, lets say 50-60%.

If we look at the picture below we will see 3 curves, Black color is the shockwave traveling to the end, green is the reflected wave and red are the summarize of the two curves. Green curve has the smallest amplitude, in this picture, color is more dark green.

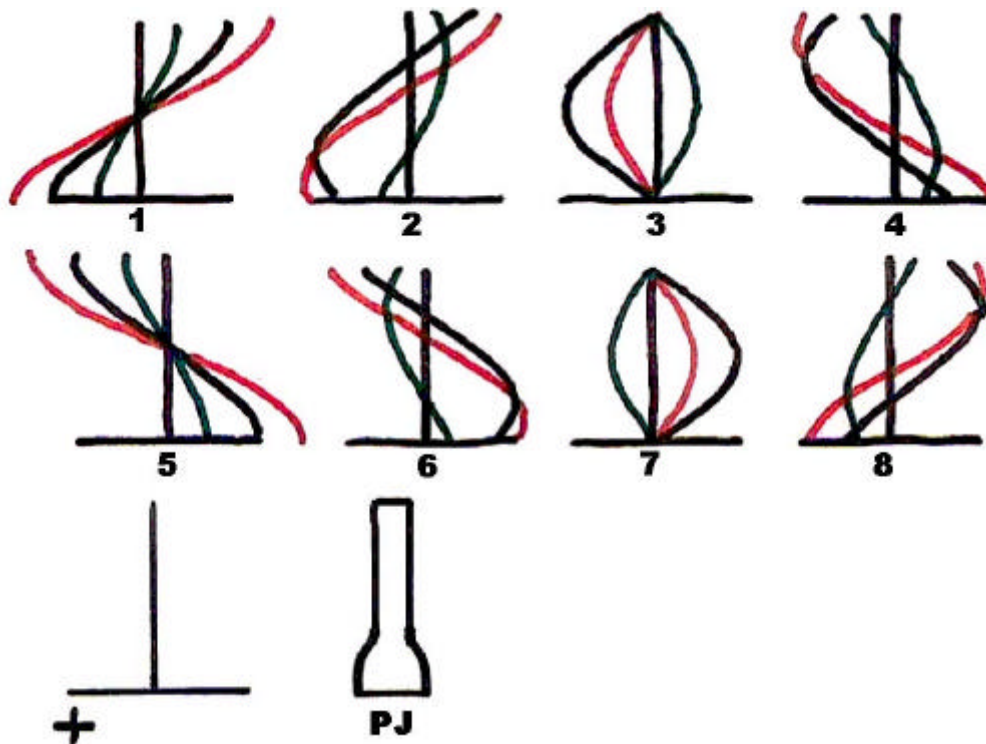

**Pic No. 3 Static pressure wave**

PJ equals to the pulsejet engine, "tube". + indicates high static pressure. Sequence is run from pos 1 to pos 8, then begins with pos 1 again. Explosion occurs when the static pressure goes high in pos 1. In this picture



the reflected wave are 50% of the forward wave. The forward wave is a constant sinus wave. In a pulsejet engine the situation are a little more different. I believe that the pressure in the forward wave won't rise above atmospheric pressure after it have fall.

If we summarize the two curves (red curve) we will see that static pressure will change more at the tube ends than in middle, so peak pressure will be higher at the valves and at the end than in the middle. If we had 100% reflection static pressure in the middle would be 0.

- As I said, high pressure makes the gasses to be pushed out of the exhaust pipe in a high speed. Due to the gasses inertia there will finally be a low pressure inside the tube, just like pulling your finger out of a bottle and you will hear a "plopp". The pulsejet works exactly the same way. This low pressure will cooperate with the static pressure resonance wave because the low pressures appear at the same time. The reflected pressure wave is at this time positive, but the summaries of the forward and the reflected static wave are negative. This pressure is what I call the **dynamic** pressure.

Let's go back to the pulsejet sequence. After the explosion, the static and the dynamic pressure will fall. This will finally open the valves and let new fuel/air mixture enter the pulsejet engine. Next thing that happens is that the resonance shockwave will raise the pressure and trigger the ignition, and a new sequence will begin.

This is the basic principle behind the pulsejet engine operation. The static pressure gives us the resonance and the dynamic pressure gives us the thrust. I think that it is this that makes the pulsejet engine so hard to overcome. The static and the dynamic pressure must synchronize to achieve a perfect resonance.

If we summarize this discussion we will see that the shape of the pipe will affect the reflected shockwave. If we compare to microwave theory an adapted antenna look something like this.

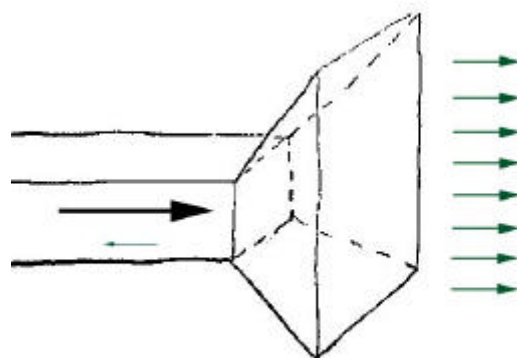

**Pic No. 4 Microwave antenna**

Black arrow is the forward signal, green arrows and the black arrow has the same energy. The reflected wave is very small compared to the forward signal.

If we make a pulsejet engine that looks like this the reflected shockwave will decrease even more, and the engine will have serious trouble to run properly. So if you would like to design a new type of pulsejet rear end you have to have this phenomenon in your head. Another thing that matters is also the relation between wavelength and resonance pipe diameter. Equals to the pulsejet length contra diameter.

Those model pulsejet engines I have seen, have a Length/Diameter L/D ratio of 15 to 17. Argus (V1) has a L/D of 8.7. I have not paid attention to the largment after the valves. The lower L/D ratio you have the more reduced reflected shockwave you will get. My guess is that the model pulsejets have a higher L/D ratio to secure a stable resonance and to lower the resonance frequency.

I believe that there are more circumstances why a pulsejet is running, but they are today beyond my knowledge.

### **Shockwave speed**

The Argus pulsejet engine had a stable resonance frequency of 43 Hz (\*\*). The shockwave travels with the speed of sound through the tube, speed of sound can then be calculated to  $3.49 \times 2 \times 43 = 300.14$  m/s. I don't have the knowledge to calculate speed of sound in a pulsejet engine with its high pressure and high temperature. But if this is true, we could have some use for this information. To find the resonance frequency to calculate the shockwave speed see chapter 3.1 question 8.

My first pulsejet had a frequency around 170 Hz and a length of 590 mm. Shockwave speed must then have been  $0.59 \times 2 \times 170 / \text{sek} \Rightarrow 200$  m/s. I think my engine did not run properly, the ignition did not occur by the shockwave. That's why 200 m/s is not equal to 300 m/s. My engine also changes frequency depending on fuel consumption.

The P90 has a frequency of 150 Hz, its length is 86 cm, this gives us a shockwave speed of  $150 \times 2 \times 0.86 = 258$  m/s.

The following conclusion is just a guess from my point of view. If you obtain a higher "shockwave" speed, the clearer or more effective the engine will run. Shockwave speed is the wrong word to use but it's also the easiest word to use. It's not the shockwave speed that increases. I think that it is the dead time between the reflected shockwave and the ignition that gets shorter, therefore "shockwave speed" increases.

As you see I'm not talking about Combustion chambers and resonance pipes any more. Paul Smith once said, "as long as the valve opening area, and the other conditions of resonance sequence are met, tube shape has little effect on the operation of the engine." The important thing is the exhaust pipe area contra the valve flow area.

So when you hear people talk about combustion chamber in a pulsejet engine they are wrong, even myself thought that once.

(\*) 15-20% is a value calculated (or estimated) by Paul Schmidt

(\*\*) According to Dave Brill

## 2.2 Equations

In this chapter I will give some clues about calculating with pulsejet engines. These equations are far away from finished, but it may be a good start to understand something. There are also some equations from practical examples. I know that there exist several different blueprints on fully operational pulsejet engines. The equations come from these engines.

### 2.2.1 *Pulsejet operation equations*

First some basic facts, I have found that the Air/Fuel ratio is something about 12-13, this means that you need 12-13 kg of air to burn 1 kg fuel at ground level. I found this information in two different reports, I think that this is correct for most kind of fuel types. 1 litre of air is approx. with 1 gram. Another fact I use is that the gas exit velocity never goes above speed of sound, right or wrong? I have approximated explosive air (air/fuel mixture) with just air, because to simplify it. They have almost the same weight. Let's begin with some variables

V = tube volume (dm<sup>3</sup> = litre.)

f = pulsejet engine operation frequency. (Hz)

va = gas exit average velocity. (m/s)

F = force, thrust (N, Newton)

fc = fuel consumption (gram/second)

m = mass in kg

t = time in second.

Equation (1) {  $m \cdot va = F \cdot t$  }

Here follows some practical examples.

#### **V1 fuel consumption**

V= 511 litre, f= 43 Hz. See chapter 3.4 pulsejet plans pic 26.

20% (\*) of 511 litre is 102.1. 102 litre of explosive fuel/air mixture = 0.102 kg. To burn this amount of air we need approx.  $0.102/12.5 = 0.00816$  kg of fuel/explosion.  $0.00816 \cdot 43 = 0.351$  kg fuel/sek. fc = 351.

We know that the V1 had around 450 litre of fuel in its tank. 450 litre is approx 380 kg. With this fuel amount it could then fly for  $380/(0.351 \cdot 60) = 18$  minutes. Which is the flying time between the coast of France to London.

## P90 studies

To find blueprint of this engine, check web address at chapter 3.4 pulsejet plans.

$V = 2.9$  litre  
 $fc = 6.7$  gram/sec  
 $f = 150$  Hz  
 $va = 258$  m/s  
 $F = 85$  Newton

“fc” is based on information from the P90 homepage 1.2 kg of fuel over 3 minutes. This number might be incorrect, because maybe not all fuel was used or burned correctly in the tube. “f” was measured from a sound file at their homepage, see chapter 3.1 Some ideas (F.A.Q) question 8, “va” are approximated to its shockwave speed, right or wrong?

From equation (1)  $m = F \cdot t / va = 85 / 258 = 0.329$  kg/second. This gives us  $0.329 / 150 = 2.2$  gram gas/explosion. At least 2.2 are less than 2.9 because the tube contains only 2.9 gram of air. I have read that the pressure during the intake cycle is the same as in ambient medium. That’s why there can’t be any more air than 2.9 gram in the tube.

If we check the fuel consumption instead, 6.7 gram of fuel needs  $6.7 \cdot 12.5 = 84$  gram of air/second.  $84 / 150 = 0.56$  gram of air/explosion. By an “incident” 0.56 gram is exactly 20% of the tube volume which Paul Schmidt said it should be.

Conclusion might be that, of totally 2.9 gram air. 2.2 gram is pushed out by 0.56 gram air/fuel mixture in an average speed of 258 m/s. And it is a **BIG** might, I have not calculated with any energy, nor temperature, nor pressure, nor efficient, so please correct me if I’m wrong.

(\*) 15-20% is a value calculated (or estimated) by Paul Schmidt

### 2.2.2 Valve flow area

Brauner, Alpha, Sov faa, B-12, Aerojet, PAM, Silnik. Is it possible that they have something in common. I have chosen these engines because they have almost the same construction. Valves and a tube as resonance pipe. Let’s check the exhaust pipe area contra the valve flow area just as Paul Schmidt said was the critical part in a pulsejet engine design.

Exhaust pipe area is simple to understand. It’s the area of a circle =  $r^2 \cdot 3.141592$ . This of course if the exhaust pipe has circle shape.

Valve flow area is little more complex to calculate. It is depending on the valve design, shape and of course the area that the valves are covering. Look at the valve design on the pulsejet engines mentioned above, flower valve shape. They have 50-60 % valve flow area contra the valve coverd area. (\*) Look at the example below and you will understand it better.

It is also important to know that this % number can change depending on the shape of the valve washer, or how smoothly the valves can open and close. It is also depending on a lot of other things in more or less degree.

Example of valve flow area:

There are 10 valves and they are covering 10 circular holes with a diameter of 10 mm in a flower valve shape. What is the valve flow area? One hole has an area of  $(10/2)^2 * 3.1415 = 79$  sq mm, ten holes has an area of  $79 * 10 = 790$  sq mm. It was a flower valve shape so the valve flow area is only approx. 55 % of the calculated area,  $790 * 0.55 = 430$  sq mm. Answer: The valve flow area is 430 sq mm.

But with the Argus pulsejet design the valve flow area was approx. 75% (\*\*) of the total area. Later you will see the calculations when I compare this engine with the small model pulsejet engines.

So, now you know what the exhaust pipe area and the valve flow area is. Let's find them in the drawings. For all these engines I have found the valve flow area as the smallest area before the valve. I build my equation upon this fact, that the pulsejet designers have tried to match the valve flow area with the smallest air input area. When I try to measure the valve covered area, I find that they differ 55% from the smallest air input area. With this as basis I say that the smallest air input area is the valve flow area. Area in sq mm.

Pulsejet engine	Y=Valve flow area	X=Exhaust pipe area
Brauner	452	907
Alpha	381	531
Sov faa	661	1195
B-12	221	531
Aerojet	603	1075
PAM	506	907
Silnik	531	1134

**Pic No. 5 Valve flow area table**

If you put these values into excel paper and then try to find linjarity, you will come up with the equation

(Europe)  $Y = 0,4922 * X - 37.$  (mm)

(USA)  $Y = 0.4922 * X - 1,45$  (inc)

If you build a larger engine you can forget about “37” or “1,45”.

This equation is the most important of all, one reason is that the engine must get the right proportion of air/fuel mix so when it detonates, the exact amount of

gases creates so a new sequence can appear. The gases must have the right velocity when it leaves the tube so new fuel and air can enter the tube.

When you look in the front of a pulsejet engine you will see that it has a smaller diameter than where the valves are. This is because we want to match that area with the valve flow area.

One idea of matching the smallest air intake area with the valve flow area is shown in the picture below.

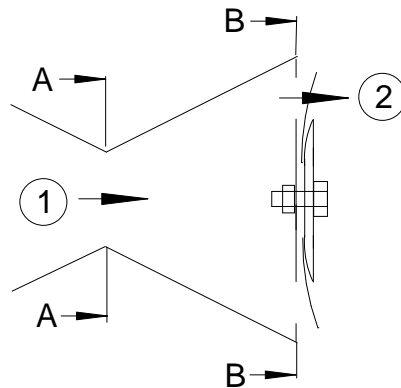

**Pic No.6 Air flow speed**

Air speed through (1) and (2) are the same, another way of seeing this is that the air speed through cross section A-A and B-B should be the same. Imagine cross section A-A much larger, then the air speed would be slower, more turbulence would appear. And if you have the fuel nozzle placed there the pulsejet would have problem to feed itself with fuel, too low underpressure.

Okey, let's compare this equation with the Argus pulsejet engine.

The exhaust pipe diameter is 400 mm, that gives us an area of 125660 sqr mm. The valve flow area should then be  $0.4922 \cdot 125660 = 61850$  sqr mm. Because there are a different valve design the valve flow area is 0.75 % (\*\*). The valve area are  $289 \cdot 375 = 108375$  sqr mm. Because the valves are mounted on a valve holder, area will be reduced with about 20% (\*\*\*). Valve flow area can then be calculated to,  $108375 \cdot 0.75 \cdot 0.8 = 65025$  sqr mm. 61850 are almost equal to 65025, only differ 5%. Check chapter 3.4 for drawings.

Let's investigate the design on the Argus pulsejet engine. Even the German designers wanted to match the valve flow area inside the tube with the so-called "diffusers". Valve flow area, calculated from valves is  $289 \cdot 375 \cdot 0.75 \cdot 0.8 = 65025$ , same as before. Smallest area behind valve is  $289 \cdot 75 \cdot 3 = 65025$ .  $65025 = 65025$ , it seems OK.

We can also check equation with team Helmonds pulsejet 90. Exhaust pipe diameter is 57.5 mm = 2597 sqr mm. Valve flow area should then be  $2597 \cdot 0.4922 = 1278$  sqr mm according to my equation. Valve area has been approximated to 2400 sqr mm. Valve flow area is  $2400 \cdot 0.55 = 1320$ . Values

differ only 3.5%, so it looks good. According to Helmonds drawing the smallest air input area is 1440 sq mm. (43.5 mm diameter-fuel injector). This number differs 10% from what we expect.

As I said before, all these values depend on a lot of things. They can change very much if something is a little bit different. So take these numbers with a pinch of salt.

Most important thing is still the resonance operation sequence. The pulsejet engine must be in a resonance. This may be difficult to achieve, but it can be done. See chapter 3.1 question 4 for practical example.

(\*) 50-60 % is a value calculated by Paul Schmidt. I have received it through Dave Brill

(\*\*) 75 % is a value calculated by Paul Schmidt. I have received it through Dave Brill

(\*\*\*) 20% is estimated by me, Argus drawings as basis.

### 2.2.3 Exhaust pipe length

My experience is that with long pipe, you will have low resonance frequency, the engine can run by itself. Short pipe, high frequency and the engine can't run without external input airflow. According to Dave Brill, the length has little effect on output power as long as the conditions for resonance sequence are met. Because in a low frequency the fuel charge are larger than higher frequency. Low frequency and larger explosions becomes equal to higher frequency and smaller explosions.

This is exactly what I have said before. If you increase tube volume, you will increase fuel mixture and this gives us larger explosions. And it's also easy to prove that the length has nothing to do with the output power for a tube shaped as a pipe.

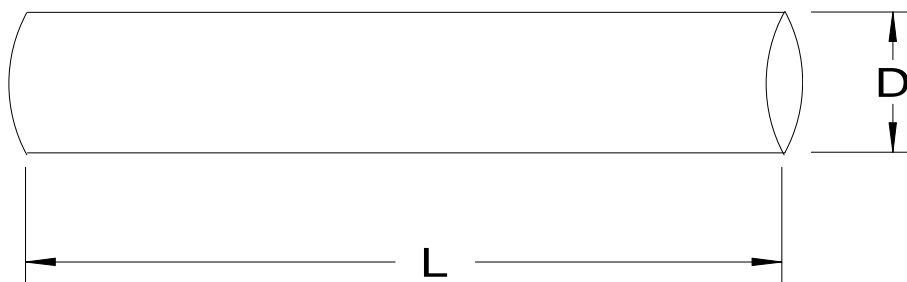

**Pic No. 7 Tube shape**

Equation to use is  $m \cdot v = F \cdot t$ .  $m$  = mass =  $X$  % air volume of the total volume in the pipe. This is  $X \cdot D^2 \cdot 3.1415 \cdot L / 4$ .  $t$  = to 1 second, during 1 second  $f$  explosions occur,  $f$  = frequency.  $f = v/L^2$ . This are put together and ends up with

$$F \text{ (Newton)} = (X \cdot D^2 \cdot 3.1415 \cdot L \cdot v^2) / (L \cdot 8)$$

As you see  $L/L = 1$ , Output power depends on only the diameter of the pipe and gas exit velocity. Final equation looks like this.

$$F \text{ (Newton)} = (X * D^2 * 3.1415 * v^2) / 8$$

If we look at our model pulsejet engines, this equation won't be adaptable because the enlargement at the valves. For those engines a specific length will produce a maximum output power. This is due to, for short pipe, the (delta) length is not linear to the (delta) volume. For long pipes it is linear. Therefore, long pipe will be closer to maximum output power than short pipe.

The main reason why the pulsejet engine looks like it does is because the valves need a lot of space in the tube. That is why it has a larger diameter where the valves are.

Comparing exhaust pipe area with total length of the pulsejet engine gives you this equation. Total length is all length after the valves.

Pulsejet engine	Y=Total length	X=Exhaust pipe area
Brauner	490	907
Alpha	485	531
Sov faa	670	1195
B-12	600	531
Aerojet	610	1075
PAM	810	907
Silnik	620	1134

**Pic No. 8 Exhaust pipe length table**

(Europe)  $Y = 0.152 * X + 470$  (mm)

(USA)  $Y = 3.88 * X + 18,66$  (inc)

This equation is only valid for small model pulsejet engines. Remember that it's better to begin with a long pipe and just cut it during the test run.

To find the resonance frequency on your engine, see chapter 3.1 question 8.

**2.2.4 Thrust (Output power)**

There are a formula to calculate the output power, and according to Dave Brill no engine has exceeded that formula. A correct built pulsejet engine delivers 4.2-4.6 pounds of thrust / sqr inc. Sqr inc means the area of the exhaust pipe. In metric it will be 0.295 up to 0.323 kilo of thrust / sqr cm. See chapter 2.2.3 Exhaust pipe length for more info.

Example, if you have an engine with the exhaust pipe area of 4 sqr inc, this engine will then deliver approx.  $4.4 * 4 = 17.6$  pounds of thrust.



Let's compare with the Argus pulsejet engine. 400 mm diameter = 15.75 inc. Exhaust pipe area is calculated to 195 sqr inc. 4.4 pounds/ sqr inc gives us the output power of  $4.4 * 195 = 857$  pounds of thrust. And that is just what the Argus engine delivered at its maximum.

Compare Helmonds pulsejet 90 with this equation. 57.5 mm = 2.26 inc. Exhaust pipe area is 4.01 sqr inc.  $4.4 * 4.01 = 17.6$  pounds. And that is 7.9 kg. Pulsejet 90 delivers 8.6 Kg of thrust.

See 2.2.3 Exhaust pipe length for pre study on this equation.

$$F (\text{Newton}) = (X * D^2 * 3.1415 * v^2) / 8$$

If we add  $X = 0.75$  as my result in the P90 engine  $2.2/2.9 = 0.75$ , see chapter 2.2.1. is equal to 75 % of the air in the tube, leaves the pipe.  $v$  are approx. to 300 m/s. This gives us the final "unusable" equation.

$$F (\text{Newton}) = 26506 * D^2, D \text{ in meter.}$$

If Einstein had  $E=mc^2$ , I have  $F=2.65*D^2$ ,  $D$  in cm.

If we compare my result with Dave Brills result. 0.3 kilo/ sqr cm are converted to  $F= 2.31*D^2$ . I think 2.31 are pretty close to 2.65, especially with all the uncertainty there are in my equation.

## 2.3 Argus pulsejet (V1)

I don't know if my conclusion below is correct, but this is the way that I have learned it. Dave Brill explained the starting sequence for me.

The development of the pulsejet engine increased 1937 when the Army Weapons Office got involved, and in November the 13, 1939 the second pulsejet prototype was proved with good result. Work continued, but when proposals were made in 1939 and 1941 to develop operational flying bombs, they were turned down. As you know, war was heading their way. A big step was made on 30 April 1941 when the original pulsejet engine was flight tested under a double-decker. Due to increasing RAF attacks on German cities, rising losses of Luftwaffe bombers and problems with the development of the V-2, things got change. After June-July 1942, the development of the V-1 started. Some minor changes were made on the engine, and soon they have a stable operational pulsejet engine to use in the V1 project, the Argus AS-014.

The first pulsejet powered flight was performed on Christmas Eve 1942. During the development of the flying bomb at Peenemunde, they encountered a series of troubles. To resolve these problems, a piloted flying bomb was developed, in which the warhead was replaced by a cockpit in which a test pilot could fly the machine while lying prone. Test flights were performed and uncovered the defects in the machine.

Several flying bombs were launched towards Sweden (my home country) to determine their range and other performance characteristics; and on June the 13, 1944, the first of over 10000 V-1 was launched towards London. Even more V-1: s was launched, but on other targets. 32000 V-1: s where built during the war.

### **Starting sequence**

Argus pulsejet engine was started with acetylene because of the gas's high flamability in colder weather. It was then switched over to it's liquid fuel and allowed to run for a few moments before the rockets were fired. The rockets were only used to accelerate the V-1 to take-off speed within the short run allowed by the take-off ramp.

Some notes have been made that they covered the rear pipe end with a piece of cardboard, just to hold the start mixture in the pipe before ignition.

### **Valves**

One of the main part in a pulsejet engine are the valves, and in the Argus pulsejet the solution is perfect. Airflow meets the valves in an angle of approx. 30 degrees. And when it starts to open up, the angle decrease from 30 to some where around 10. Our flower shape valves are different. Airflow meets the valves at 90 degrees and when these are fully open the angle is approx. 75 degrees. This is why Argus pulsejet valves compared to flower shape valves are much better.

Se chapter 3.1 question 3 for picture

### **Ignition**

To ignite the pulsejet engine a sparking plug is mounted on the top of the engine.

### **Fuel**

There are 9 fuel injectors, and they are placed just after the valves. There are also 3 other nozzles for starting and for pressure sence. During the start sequence fuel was blow through these nozzles. When the V1 is flying the nozzles was sensors.

There are two fuel pipes going from the fuselage to the engine, the one closest to the valves are for fuel, the other one are used for starting and for preasure sence.

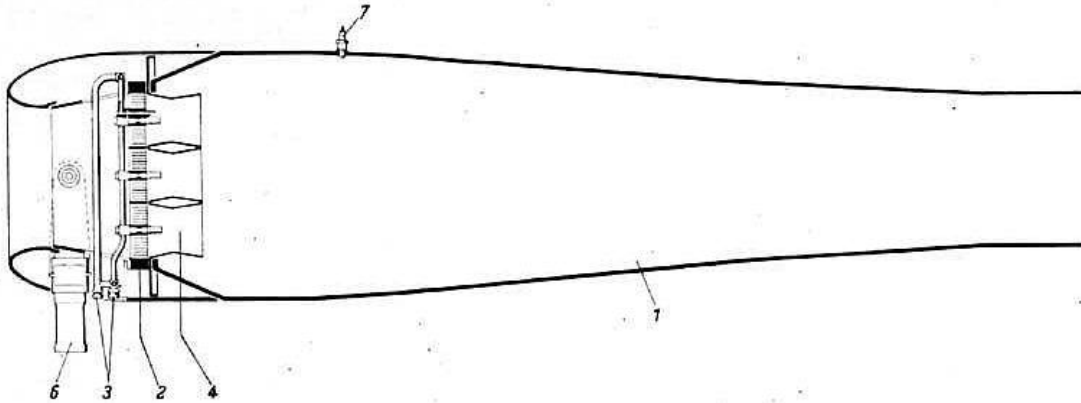

**Pic No. 9 Argus pulsejet engine**

This is the famous Argus pulsejet engine, it is a little bit longer than it is in this picture. Se chapter 3.4 Pic No.26 Argus drawings

Thrust, static	approx. 500 pounds, 210 kg
Thrust, flying	approx. 750 pounds, 320 kg
Length:	137.4 inc 349 cm
Width:	22.4 inc, 57 cm
Fuel:	Low octane fuel.
Fuel consumption:	approx. 26 litre/minute



**Pic No. 10 Fieseler Fi 103 (V1)**

Picture taken at a War Museum some kilometers from London, I've forgot the name of it.

## 3. Building your own pulsejet

### 3.1 Some ideas (F.A.Q)

I will in this chapter give you some clues about how to build pulsejet engines. If you for example have all special equipment, I recomend you to build an already designed pulsejet engine, ex. Brauner design. But if you, as me don't have all tools you will have to change the design. I will also try to answer some other important questions.

- 1. Where should the fuel enter, “inside” or “outside” the engine?**
- 2. How long exhaust pipe (resonance pipe) must I have?**
- 3. What kinds of valve typs (designs) are there?**
- 4. I want to design my own pulsejet engine, how do I do?**
- 5. What kind of fuel should I use?**
- 6. How do I easily put all parts together?**
- 7. How do I start the engine?**
- 8. Do the frequence match the resonance pipe lenght?**

#### **1. Where should the fuel enter, “inside” or “outside” the engine?**

With inside I mean that the fuel injector is placed just after the valves, equal to the place where the “explosion” begins, occur. Outside means that it is placed just before the valves.

The main difference is that if you put the fuel injector inside it would be safer, less chance that flames comes out in the front of the engine. I also think that the fuel consumption will be a little less. Otherwise there are small or none differences.

#### **2. How long exhaust pipe (resonance pipe) must I have?**

I would recommend you to make it a little longer. I think it easier to start the engine with longer pipe than shorter. And it definaly more easier to cut than to make it longer.

Don't make the wide part to long, only approx. 20% of the total lenght.

Se chapter 2.2.3 for equation.

#### **3. What kinds of valve typs (designs) are there?**

- A. Flower valve shape**
- B. Argus design (grid type)**
- C. My own design (reed shape)**
- D. Angled valve design**

A. This is the usual design for model pulsejet engines.



**Pic No. 11 Flower valve shape**

This is the usual valve design for model pulsejet engines. Valve construction may differ from model to model but on average, they look like this.

B. This design is probably one of the best, better than flower shape.

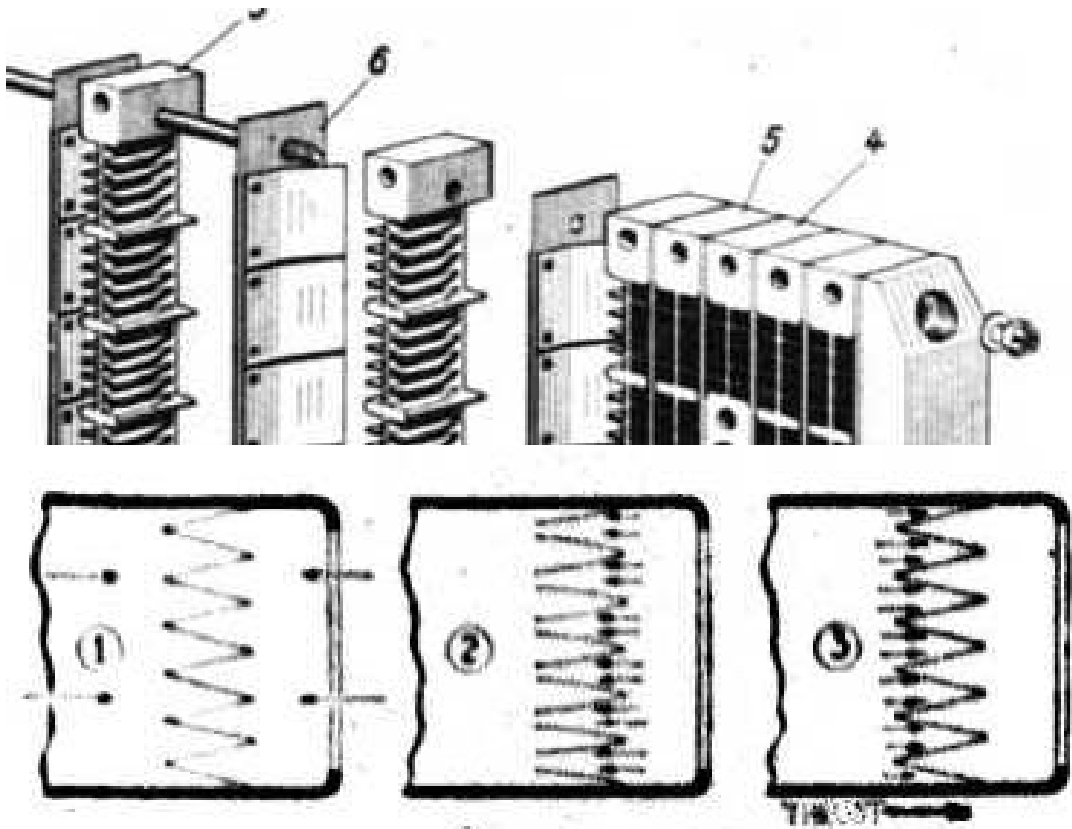

**Pic No. 12 Argus valve design**

Highest picture shows how the valves are assembled. Picture below describe its function. (1) Same pressure inside and outside the engine. (2) Low pressure inside engine, valves open up and new air/fuel enters the engine. (3) Explosion occur and the valve stop the forward flow.

C. My own design (reed shape) is a combination of the two above.

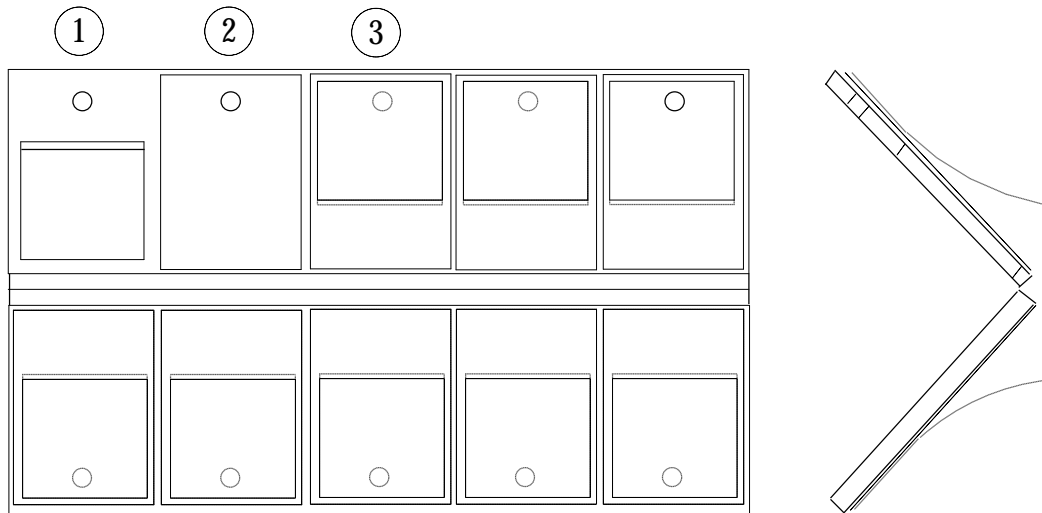

**Pic No. 13 My own valve design**

(1) Nothing is mounted on the valve plate, just a hole in the plate (2) Valve is assembled. (3) Valve holder added with bolt through everything. Valve is now complete. I have also seen this valve shape in two stroke engines, I think it's called "reed valve" or something.

D. Angled valve design. This is an attempt to reduce the "large part" diameter

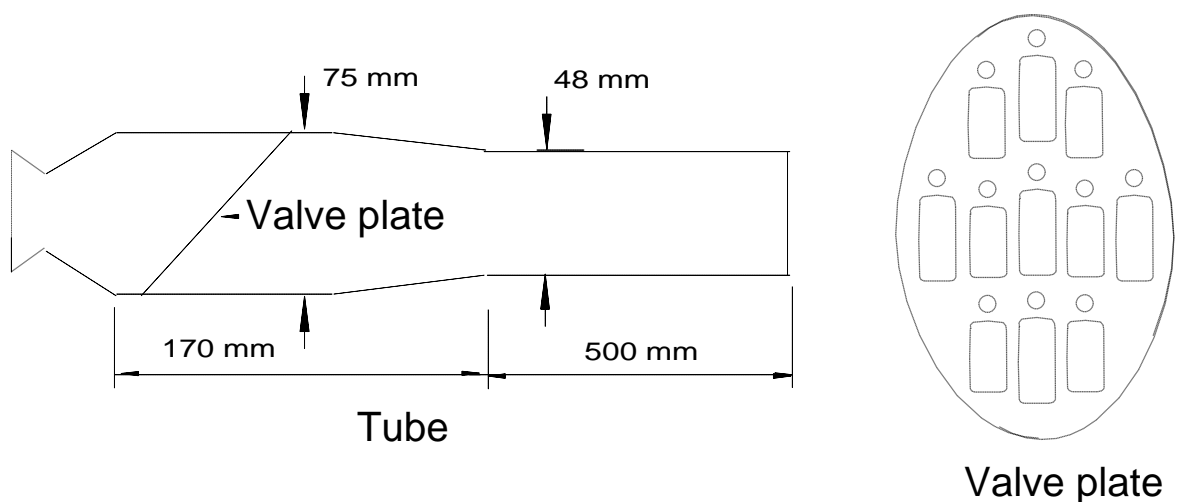

**Pic No. 14 Angled valve design**

This valve design has two big differences from the 3 examples above. It is not symmetric and the air/fuel mixture won't enter the tube symmetric. Will it work? I

really don't know that, this is just an idea. My primary goal with this design is to create a good, simple and easy build pulsejet engine. If I compare the ratio, "valve" diameter (largest) and the resonance pipe diameter, between this engine and the P90 we will see that they are the same. If my engine has the right dimensions and the asymmetric design won't reduce power, this engine might be as good as the P90.

What is the advantage with this design, practically this engine will be very easy to build. I have right now the building description in my head and I will print them when I build this engine. The advantage theoretically will be a larger cross section valve area. This will increase the valve cover area and of course the valve flow area/ factor. Since valves don't have to open/bend so much too fully open up.

Negative things might be some turbulence in the air intake, and it will be difficult to reduce them. One thing that I don't know anything about is how much the efficiency will be reduced due to the asymmetric design.

#### **4. I want to design my own pulsejet engine, how do I do?**

First of all you have to know how strong engine you need, that's important, because it depends on the rest of the construction. I want my engine to deliver 25 pounds of thrust, what do I do? Okay! Let's calculate exhaust pipe area,  $25/4.2 = 5.95$  sq in. This gives us a diameter of 2.75 in. The valve flow area can be calculated to  $5.95 * 0.6552 = 3.9$  sq in. So if you use a flower valve shape the area covered by the valves should be at least  $3.9/0.55 = 7.1$  sq in. And with 18 holes, each hole must be 0.39 sq in.

Now you start to see what a big engine this will be. Let's see how long it needs to be.  $5.95 * 3.88 + 18.66 = 41.8$  in long exhaust pipe (tube). Make it instead 50 in just in case.

The wide part after the valves can be around 8 in long ( $0.2 * 41$ ). Now let the cone and the resonance pipe be total  $50 - 8 = 42$  in. This will make the exhaust pipe  $42 + 8 = 50$  in long. This is of course excluding valves and "valve house"

As I said before, the smallest air input area is equal to valve flow area, equal to 3.9 sq in. This is equal to a diameter of 2.23 in. The smallest diameter where the air enters the pulsejet engine should be 2.23 in.

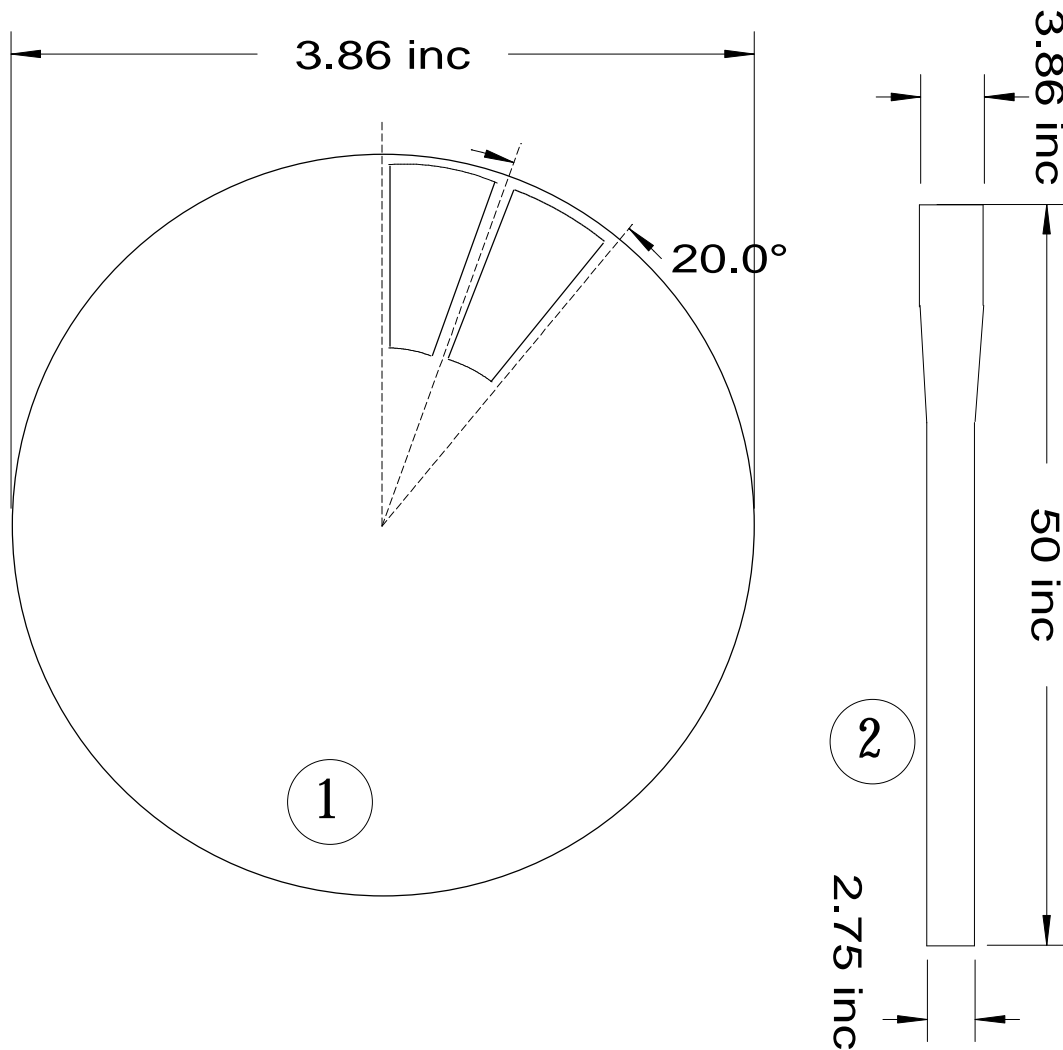

**Pic No. 15 Pulsejet engine design**

(1) Valve plate with 18 holes. Each hole has an area of 0.39 sqr inc. (2) Tube. What is missing is the valve house front, use my design as in question 7 in this chapter. Smallest area should be 3.9 sqr inc. Equal to a diameter of 2.23 inc. This drawing is more or less an overview. Don't build anything with this drawing as basis.

Tip: My experience is that it is better to make the valve flow area a little larger than found in my equation. Because in reality, the engine will then be a lot more easy to start. Even increase the smallest air input area a little. If you make the valve flow area too small you will have serious trouble with your engine (I know). My equation is more or less for an optimized design when everything works perfect.

### 5. What kind of fuel should I use?

I have right now none experience in this matter. I have only used car petrol as fuel. But I do know that some guys in Netherland are using a fuel with the



compounds, 53 % Kerosine JP-4 or Jet A-1. 40 % Gasoline. 7 % Propylene oxide C<sub>3</sub>-H<sub>6</sub>-O. I suggest that you use this fuel.

### 6. How do I easily put all parts together?

Look at my drawings and you will find out a easy way to build a pulsejet engine, maybe not the best but you can do it in your garage.



### Pic No. 16 Pulsejet assambly

The highest picture shows all parts unassambly, to the right, reconance pipe, in the middle valve plate, thats where the valves are mounted. To the left, from the top, valve house, middle section and the cone.

In the middle picture you can see the valve house assembled. Holes have also been drilled in the valve plate. The tube is now almost finished

The lowest picture shows how to mount the valve house on to the tube. I have used 10 M 4 bolts to keep them together.

This is a very simple way to build a pulsejet engine. Please don't forget to add the cone in the valve house as I did. Without this part the air won't go smooth through the valve house and the engine may not run properly.

### **7. How do I start the engine?**

If you use high-octane fuel you properly don't need any propane gas. So then simply light a sparkler and lead it into the pulsejet engine from behind, put it just after the valves. You might need to lock it in there with a wire that reaches outside the engine. Fit the outside part of the wire to the ground. Use high-pressure air to blow air into the front and at the same time turn on the fuel line. Repeat this procedure until the engine starts. The sparkler will burn out in about 25 seconds.



**Pic No. 17 Start attempt on my second engine**

If you use low octane fuel you will have to use propane gas before you turn on the fuel line. So, let the engine run on propane gas for 15-20 seconds before you turn on fuel line and shut down gas line. The propane gas is mixed with the air before entering the pulsejet.

I have myself tried a sparking plug with no success. I always had to start the engine with a sparkler. When the engine was warm, I could start it with the plug. This might help you during the tests, but not when the engine is ready.

## 8. Do the frequency match the resonance pipe length?

If you have problem with your resonance frequency, can you measure it and see if it matches the resonance pipe length. In this program the frequency scale begins at 80 Hz and goes up to 450 Hz, it's used to find guitar chords.

First you record a wave file of the sound, a taperecorder works perfect. Record the sound in the computer through the soundcard in .wav format with at least 11025 sample speed and 8 bits. Then download "dsChordFinder" from the internet. Shareware version will only work for 30 days. Start "dsChordFinder" and open your wave file. Press "Play" and when you hear your engine clear press "Stop", go to the "Frequency Window", the lowest top are the resonance frequency or an overtone, It may be difficult to find a top, or to know which one is the correct, but after a while you will find it.

Investigating V1 sound over London, found at "[www.zenza.se](http://www.zenza.se)", I measured the third overtone to 230 Hz down to 150 Hz, fly by. So mid frequency is 190 Hz, this gives us a resonance frequency of 47.5 Hz, that is almost equal to 43 Hz. If we calculate the lowest possible speed we found out that it is 56.6 m/s => 204 km/h, Doppler effect. Lowest speed if V1 was passing straight over the recording media on low altitude. Which properly not happen, so the speed was higher.

## 3.2 My pulsejets

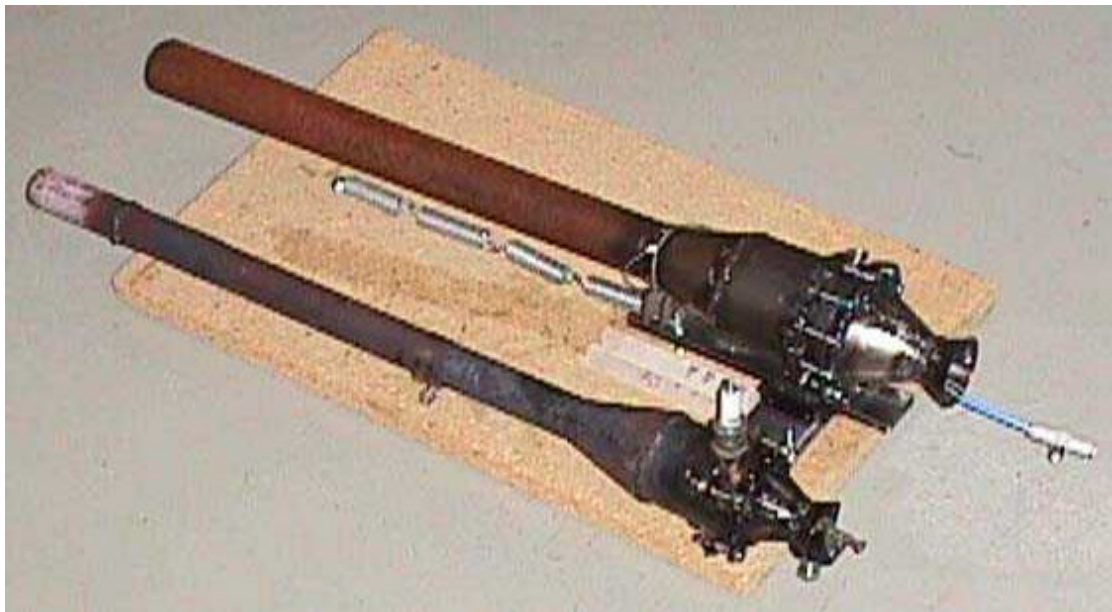

**Pic No. 18 Two pulsejets**

The lowest pulsejet is my first engine, I think it delivered something about 0.8 kg thrust. After modifying it too much, this engine was very hard to start. The other engine is my latest, It has not run in resonance yet, only big BOOMS. I think I know what the problem is, I have a too large resonance pipe or my valve flow

area is too small. So there are two ways to fix it, change pipe or increase valve flow area.

The fuel injector is placed before the valves on both pulsejets.

The Argus pulsejet engine was built in steel, except the valve holder. I have myself used the same idea. My valves are made of blade steel or spring steel. The rest is mainly built of steel pipes and steel plates.

Check out my homepage, there will you find more info about my pulsejets, "<http://www.geocities.com/Area51/Rampart/9722/welcome.htm>".

### 3.2.1 *Building Description*

See chapter 3.4 Pulsejet plans "Pic No. 25 My own drawing". All numbers described in this text has a corresponding number in the drawing.

This is the building description of my latest engine, design has been changes so it should work now. Look at my homepage for latest information, see chapter 3.2 "My pulsejets" for internet address.

Engine consists of 7 main steel parts. Rest is valves, bolts, nuts, fuel injector and holds.

Part namn:	Material:
(1) Resonance pipe	Steel pipe
(2) Wide part of the tube	Steel pipe
(3) Con between (1) and (2)	Steel plate
(4) Valve plate	Steel plate
(5) Con (back part of valve house)	Steel plate
(6) Con (front part of valve house)	Steel plate
(7) Valve washer	Steel plate
(8) Valves	Spring steel or blade steel.
(9) Bolts	Steel
(10) Nuts	Steel
(11) Holds	Steel
(12) Washer	Steel
(13) Washer	Steel
(14) Anti-trubulence cone	Aluminium or steel

(9) and (10) are ordinary bolts and nuts, 1, M6x25 and 10, M4x30.

First of all you can manufactor all separate details. No. 1 and No. 2 are ready when you have cut them in its correct length. With No. 3 you'll have to bend to a con, weld the splice. No. 4 is a little more difficult. Drill a hole i center, then you have to drill all valve holes, use a file to change the shape of the holes. Remember that the "valve" side MUST be even, if not, valves can never be tight and the engine won't run.

After that you drill all periphery holes. They are later used to attach the tube. This is a very important part, do this very carefully. Do the same with No. 5 and 6 as with No. 3. Use a lathe and make No. 7. This part is also important, but this part is easy to reproduce and exchange. No. 14 is made of aluminium or steel, this detail will reduce the turbulence in the valve house.

Weld No.5 and 6 together. When you are satisfied with your valve plate, weld it together with No. 5 and 6. Remember that it's more difficult to change the shape of the valve plate after this procedure. Before you do anything thing with the tube part, make sure that "valve" side of No. 2 is flat and even. Because this side have to be tight when its mounted to the valve plate. Now weld No. 3 to the other side of No. 2. And then No. 1 to No. 3. Now the "tube" is ready.

Cut out No. 11 from a steel plate and drill a hole in the middle, make the hole a little larger than the bolt. Now it time to weld these holds to the tube. I recommend you to first weld two holds on opposite side of the tube. Fit the valve house very easy on to the tube with two bolt and nuts. Use the remaining holes to weld the remaining holds.

Now it begins to look like an engine. Now its time for the valves (8), cut the valves so they overlap the hole with at least 0.5 to 1 mm on every side..Next step is to mount them on the valve plate. This is the simplest way. Mount the valves one by one, use tape to fix one valve steady. When you are finished, all valves should be attached with a piece of tape. Next step is to screw the valve nut.

When you screw the valve nut hard, valve plate might become deformed. If so, use extra washers to prevent this. The deformation will now appear in the washer instead of valve plate.

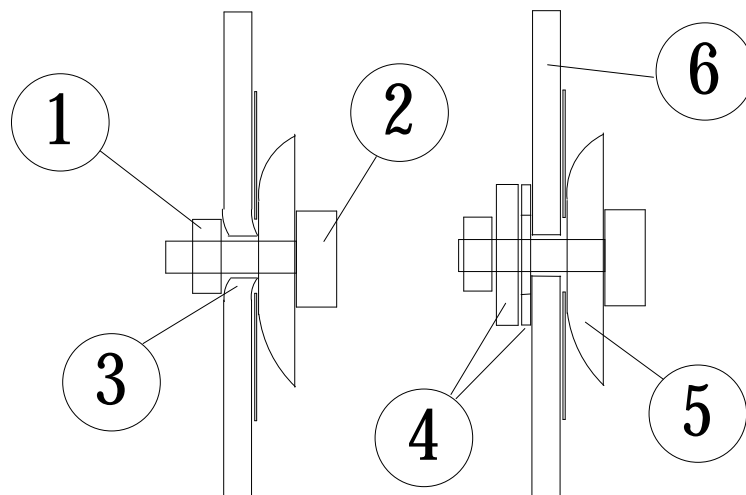

**Pic No. 19 Valve plate deformation**

(1) Nut, (2) Bolt, (3) deformation will appear here. To prevent this add extra washers (4) closest to valve plate one with a big hole, the other one with a hole as the diameter of the bolt..(5) Valve washer, (6) Valve plate. Deformation will now appear in the washer instead.

Next step is to add a fuel injector. Look at the picture and I hope you will understand.

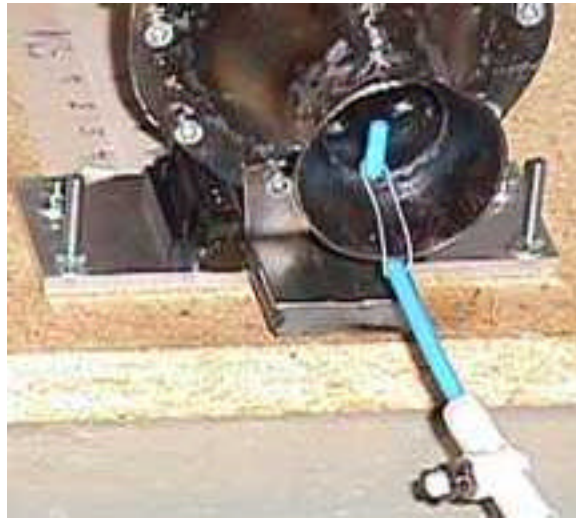

### **Pic No. 20 Fuel injector**

On the picture you can see a plastic hose attached to the pulsejet through a hole in the valve house. This is properly not the best way but I think it will work. Look at the other drawings and make another fuel injector if you have more time.

Screw No (14) on the bolt inside the house, if the bolt is too short, change it to a longer.

After you have fit the valve house on to the tube, use your mouth to blow in the resonance pipe and you can determine if it is tight or not. If it leaks a little air is okay, but if you feel no resistance then something is wrong. First check if it leaks between the tube and valve house. If it does the tube edge is not round. Use grinding paper and make the surface even.

If it doesn't leak there, it properly would be the valves. Try to find the bad valve and replace it.

If the engine is tight, it is ready for TESTRUN!!!!!!!!!!!!!!!!!!!!!!

### **Fuel supply**

There are a lot of different ways to handle the fuel supply. I simply had a bottle 1 meter above the engine to create the pressure that I needed. When you have a perfect working pulsejet you can begin with balloons filled with fuel. The balloon will then give you the pressure you need.

I have also heard that you can use a regular model fuel tank. The pulsejet will draw its own fuel to the fuel injector. I have not tested this yet.

### 3.3 Future project.

Later in the future I will start to build a large pulsejet engine, smaller than the Argus, but still no model pulsejet engine. It will deliver 70-80 Kg thrust and I will use it as propellant for my ice yacht. With this engine I will try to use my own valve design, se chapter 3.1 question 3. When doing so I will “try to” reduce the diameter of the wide part. Resonance pipe diameter must be 17 cm, lenght about 2 meters.

Calculations: Valve flow area must be  $226 \cdot 0.4922 = 111.7$  sqr cm. Valve area must then be  $111.7 / 0.7 = 159$  sqr cm. Valve area are approximated to be  $2 \cdot 1.2 \cdot 13 \cdot 6 = 187$  sqr cm. I'm not sure about this, because I have no experience with this type of valve design. So I presumably have to redesign the pulsejet later when it comes to resonance pipe diameter and smallest air intake diameter, smallest air intake are right now 12 cm diameter => 112 sqr cm.

As I said, this project is somewere in the future, don't expect anything to happend within 2-3 years.

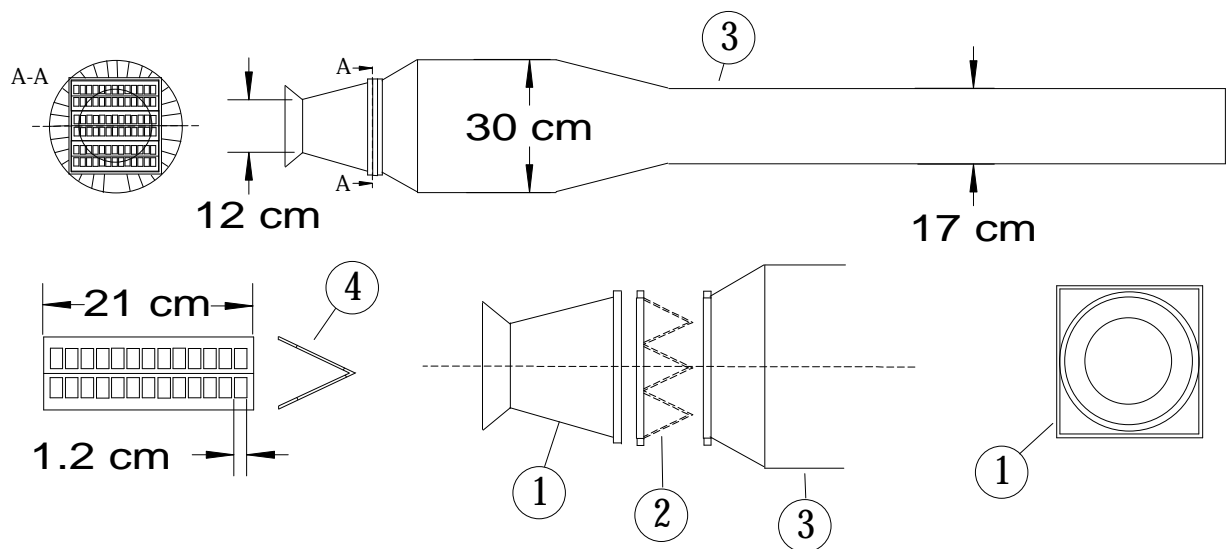

**Pic No. 21 Large pulsejet engine design**

(1), Front cone, (2) Valve plate, 78 valves, (3) The tube, (4) One valve row with  $13 \times 2 = 26$  valves.

Only thing that differ this engine from the rest model pulsejets are the valve design. I am not really sure if I need the front cone, I will instead match the valve flow area inside the engine with “diffusers”, just like the Argus engine.

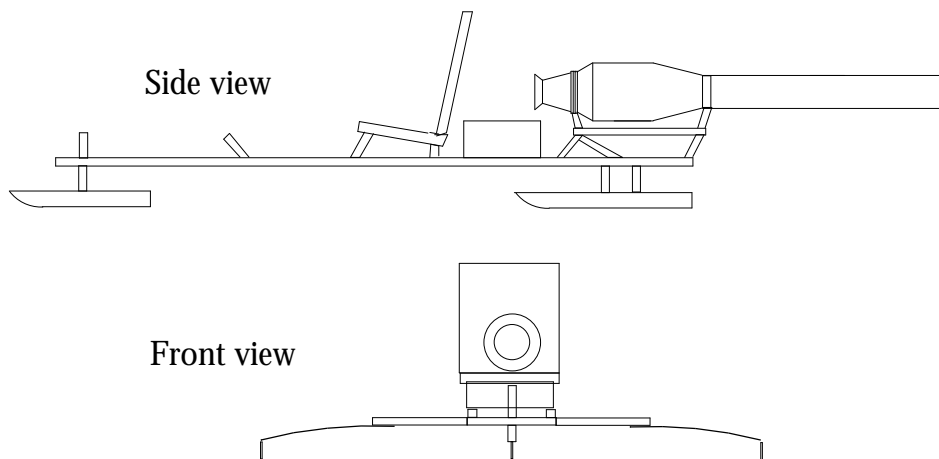

**Pic No. 22 Ice yacht**

Speed... over 200 Km/h? Fuel consumption? 5 liter/minute. Dangerous.. yes.



### 3.4 Pulsejet plans.

Brauner drawings, Alpha drawings, My own drawing , Argus drawings. If you want the drawing on the Team Helmonds pulsejet 90, please go to the internet address “<http://pulsejet.amtjets.com>”.

All measures are in metric “mm”

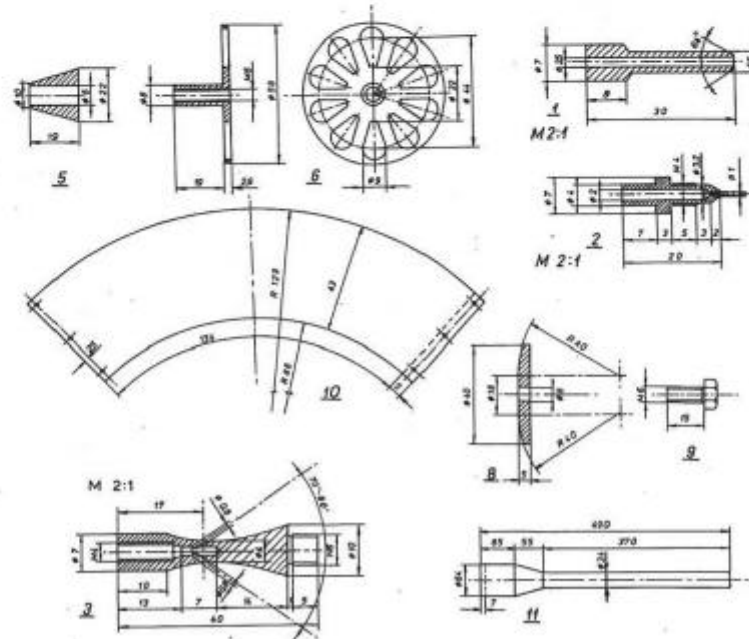
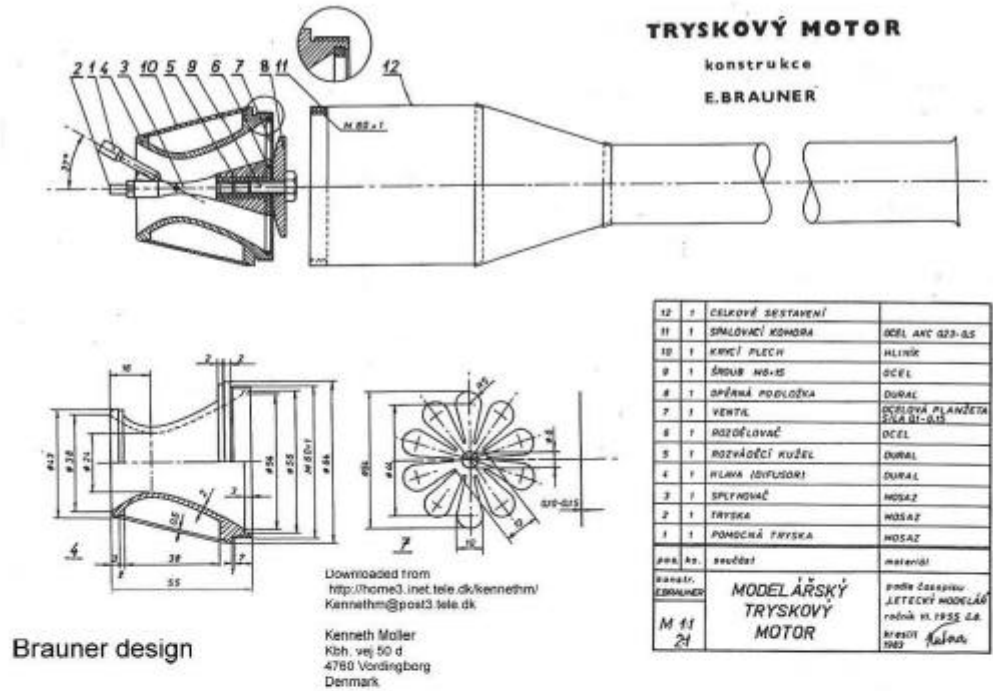

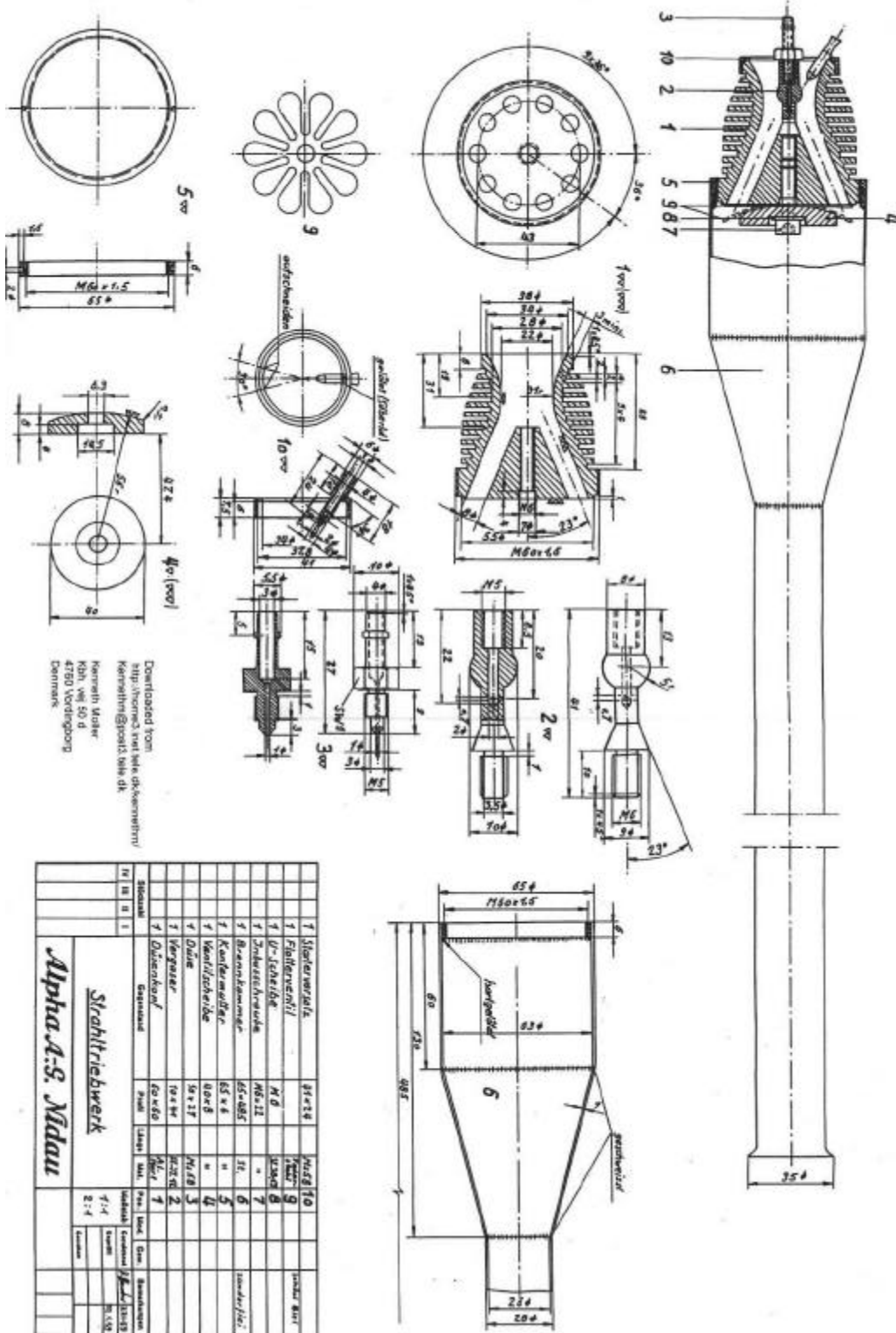

Pic No. 24 Alpha design

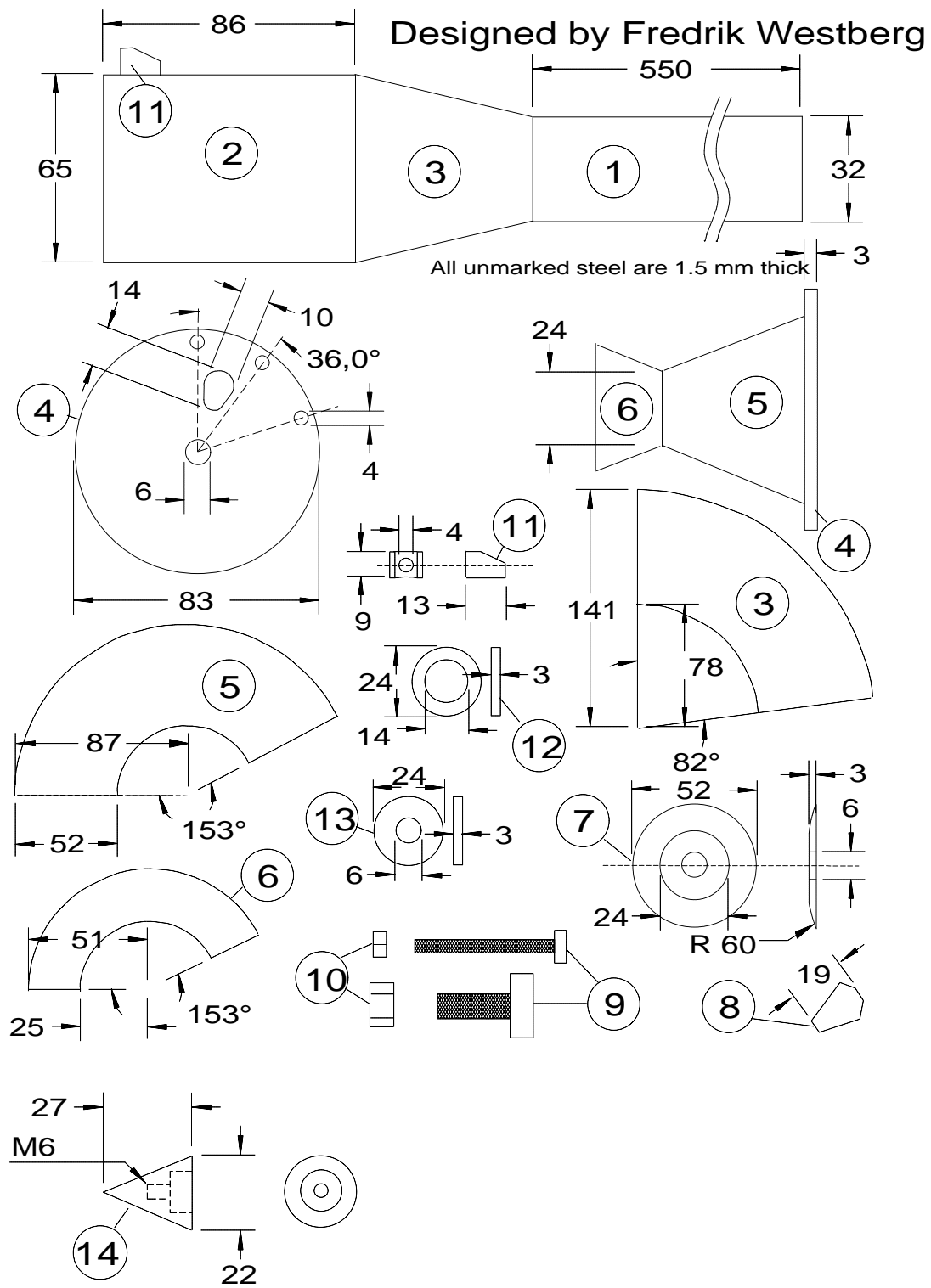

Pic No. 25 My own drawing



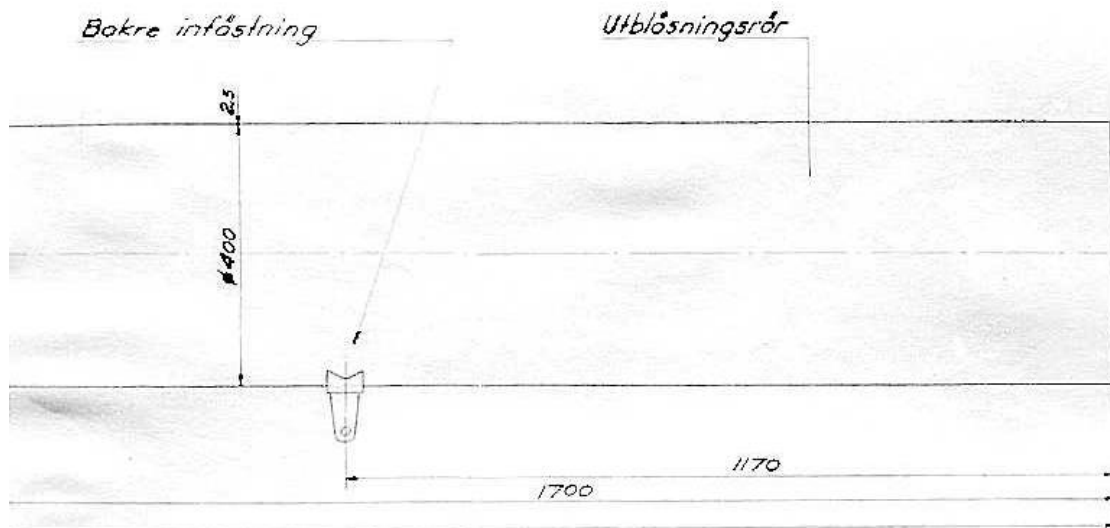

**Pic No. 26 Argus pulsejet engine**

This "Swedish written" blue print is made from V1 prototypes who was fired towards Sweden in the begining of the war to determind performance characteristics. Se chapter 5 Glossory. For translation on some Swedish words.

Go to Kenneths homepage if you want the drawings in a better quality, there will you also find more than 17 other pulsejet plans availble to download for free. "<http://www.pulsejets.com>".

#### 4. Conclusion.

Pulsejet engines compared to jets are very easy to build. So, if you are building modelaircrafts and are interested in highspeed. I can recommend you to build a pulsejet engine. But please go into this project with an open mind and a motto, "It dosen't have to work" cause otherwise you might be disapointed and angry on me, and it's not my fault.

You can also build this engine if you want to do something odd or terrorise your neighbors. Cause it has a real terrible sound.

Hope you understand the pulsejet engine a little better now, cause that is what this paper was suppose to do.

If anyone want's to add/rewrite anything to this document, please dont hesitate to contact me.

## 5. Glossary

“**Valve flow area**” is the real input area that the pulsejet engine experience during it’s reconance. This area is a less than the area covered by the valves, this due to the valves inherta, and that they will never be realy fully open.

“**Valve opening area**”, I’m not sure but I think it’s the same as valve flow area.

“**Valve coverd area**” is the hole area in the valve plate, valves are covering this holes.

“**Luftintag**” trans. Airintake.

“**Ventilgitter**” trans. Valvegrid

“**Diffusor**” trans. Diffuser

“**Tändstift**” trans. Sparking plug

“**Förbränningskammare**” trans. Combusting chamber

“**Bakre infästning**” trans. Rear holds.

“**Utblåsningsrör**” trans. Exhaustpipe.

## 6. Sources

“**Dave Brill**” has give me a lot of information about the pulsejet theory, he has also been a great help with discussion things of different matter.

“**Leslie W Lassiter**” Technical note 1756 “Noise from intermittent jet engines and steady-flow jet engines with rough burning”

“**D.Z.G**” (Germany Contemporary History, personal homepage) had some information about the Argus pulsejet engine.

“**Greg Goebel**” had some information about the V1 project.

“**Göran Johansson**”, here I found pictures, drawings on the Argus engine

“**Kenneth Möller**” had drawings on some model pulsejet engines. He’s homepage address is “<http://www.pulsejets.com>” according to me it’s one of the best.

“**Team Helmond**”, I have used their engine design as basis on my research.

“**Eric Van den Bulck**” gave me some information about Argus AS-014

“**Remko Klaassens**” gave me info about the origin of the P90, also some pics.

## 7. Index

Air/Fuel ratio.....	p. 11
Argus AS-014, V1.....	p. 5, 6, 7, 10, 13, 17, 27, 37
Buzz bomb.....	p. 5
Combustion chamber.....	p. 10
Design tip.....	p. 24
Dynamic pressure.....	p. 9
Fieseler fi 103.....	p. 5, 19
Forward wave.....	p. 9
Fuel/air mixture.....	p. 7, 11, 13
Gas exit velocity.....	p. 11, 16
L/D ratio (Lenght/Diameter).....	p. 10
Micro antenna.....	p. 9
Paul Schmidt.....	p. 7, 10, 12, 15
Pressure resonance.....	p. 8
Pulsejet starting.....	p. 18, 25
Reed valve.....	p. 22
Reflected wave.....	p. 9
Resonance sequence.....	p. 8, 15
Resonance frequency.....	p. 7, 8, 10, 15, 27
Shockwave.....	p. 7, 8, 9, 10, 12
Speed of sound.....	p. 10
Static pressure.....	p. 8, 9
Team Helmonds P90.....	p. 6, 14, 17, 33
Termination.....	p. 8