

# LOCK NUT

## LOCK NUT

**Would you like to change your drawing ?**

No need for lock washer, nut, key, key home working for shaft.

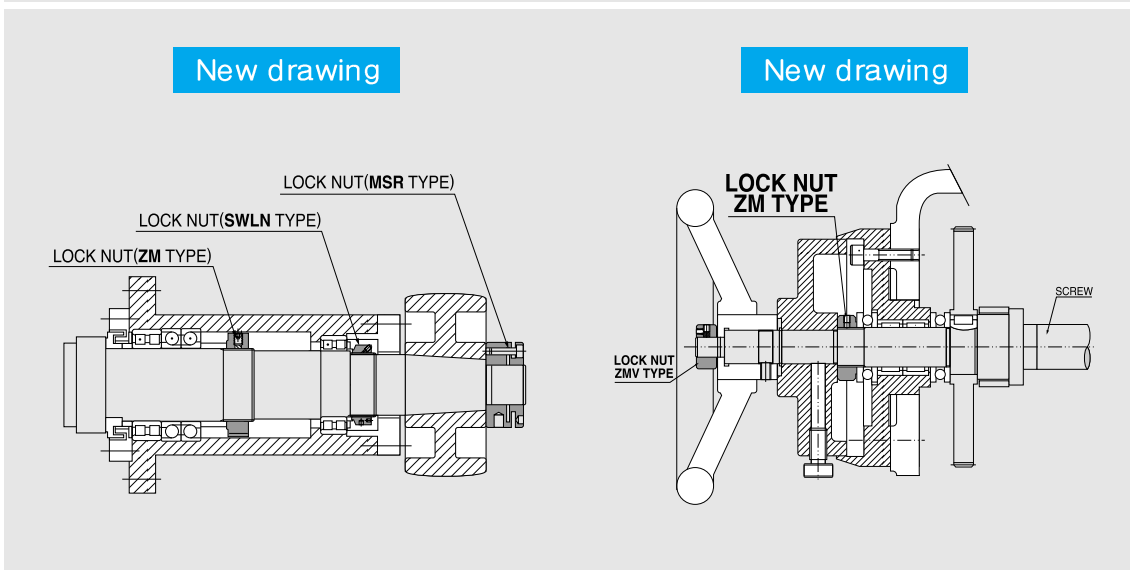
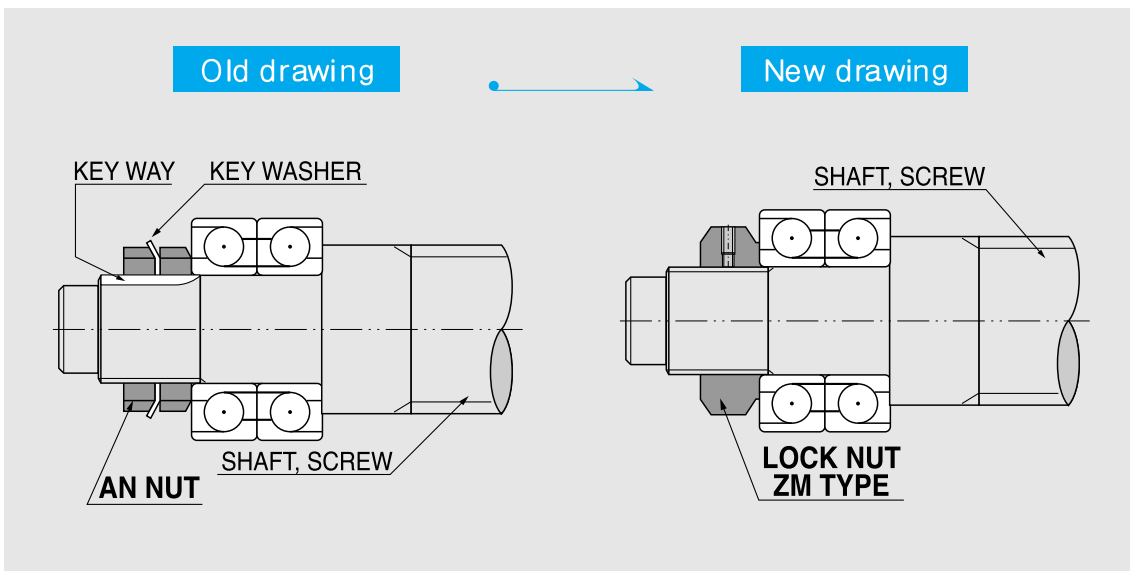

# PRECISION LOCK NUT

## ZM Type

### Features

- ▶ Material : DIN C45, JIS S45C, KS SM S45C
- ▶ Hardness : HRC 22~25
- ▶ Nut Grade : Precision class
- ▶ Squareness of Nut Face :  $\pm 0.007$
- ※ ZMA (Special)

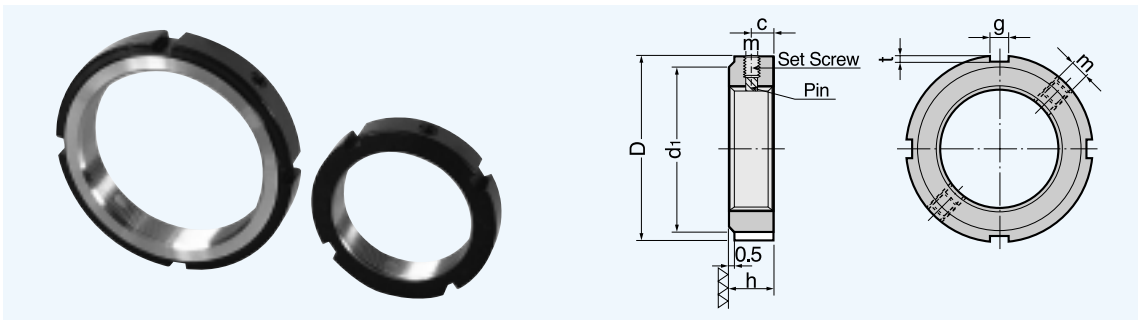

Dimension :mm

PART NO	THREAD & PITCH	Dimensions							Axial Load (KN)	Set Screw (N m)	Weight (g)
		$\phi$ D	h	g	t	d1	c	m			
ZM 6	M 6 × 0.5	16	8	3	2	12	4	M4			
ZM 8	M 8 × 0.75	16	8	3	2	12	4	M4			
ZM 10	M 10 × 1	18	8	3	2	14	4	M4	22	4	8
ZM 12	M 12 × 1	22	8	3	3	16	4	M4	26	4	14
ZM 15	M 15 × 1	25	8	3	3	19	4	M4	33	4	16
ZM 17	M 17 × 1	28	10	4	3	21	5	M5	49	7	24
ZM 20	M 20 × 1	32	10	4	3	25	5	M5	55	7	34
ZM 25	M 25 × 1.5	38	12	5	3	31	5	M6	87	7	54
ZM 30	M 30 × 1.5	45	12	5	3	38	6	M6	110	7	76
ZM 35	M 35 × 1.5	52	12	5	3	45	6	M6	120	7	102
ZM 40	M 40 × 1.5	58	14	6	3	50	7	M6	150	7	144
ZM 45	M 45 × 1.5	65	14	6	3	56	7	M6	170	7	180
ZM 50	M 50 × 1.5	70	14	6	3	61	7	M6	180	7	196
ZM 55	M 55 × 2	75	16	7	4	66	8	M6	250	18	240
ZM 60	M 60 × 2	80	16	7	4	70	8	M8	270	18	262
ZM 65	M 65 × 2	85	16	7	4	76	8	M8	290	18	282
ZM 70	M 70 × 2	92	18	8	4	82	9	M8	350	18	378
ZM 75	M 75 × 2	98	18	8	4	87	9	M8	370	18	422
ZM 80	M 80 × 2	105	18	8	4	92	9	M8	390	18	492
ZM 85	M 85 × 2	110	18	8	4	99	9	M8	400	34	524
ZM 90	M 90 × 2	120	20	10	4	105	10	M8	470	34	750
ZM 95	M 95 × 2	125	20	10	4	110	10	M8	490	34	782
ZM 100	M 100 × 2	130	20	10	4	116	10	M8	510	34	826
ZM 105	M 105 × 2	140	22	12	5	122	11	M10	560	34	1,108
ZM 110	M 110 × 2	145	22	12	5	129	11	M10	600	34	1,164
ZM 120	M 120 × 2	155	24	12	5	136	12	M10	710	34	1,378
ZM 130	M 130 × 2	165	24	12	5	145	12	M10	760	34	1,480
ZM 140	M 140 × 2	180	26	14	6	156	13	M12	880	60	1,958
ZM 150	M 150 × 2	195	26	14	6	167	13	M12	930	60	2,404
ZM 160	M 160 × 3	210	28	16	7	178	14	M12	980	60	3,080
ZM 170	M 170 × 3	220	28	16	7	189	14	M12	1,130	60	3,256
ZM 180	M 180 × 3	230	30	18	8	199	15	M12	1,300	60	3,628
ZM 190	M 190 × 3	240	30	18	8	210	15	M12	1,470	60	3,928
ZM 200	M 200 × 3	250	32	18	8	222	16	M12	1,600	60	4,330



## ZMV Type

### Features

- ▶ Material : DIN C45, JIS S45C, KS S45C
- ▶ Hardness : HRC 22~25
- ▶ Nut Grade : Precision class
- ▶ Squareness of Nut Face :  $\pm 0.007$
- ※ ZMVA (Special)

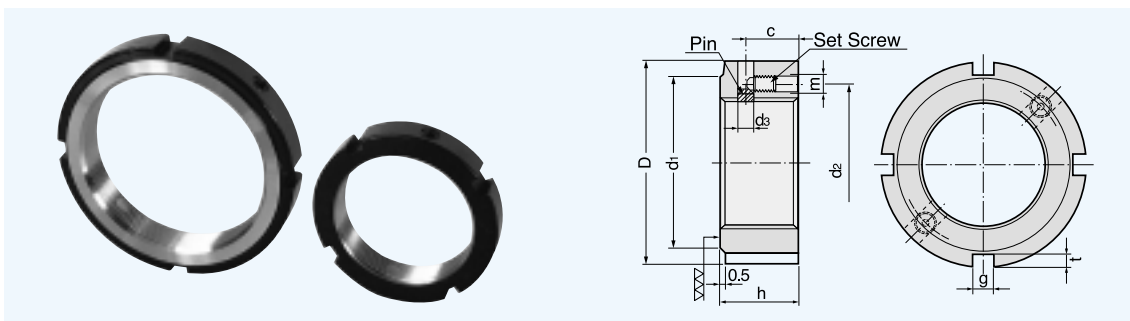

Dimension :mm

PART NO	THREAD & PITCH	Dimensions									Axial Load (kN)	Set Screw (Nm)	Weight (g)
		$\phi$ D	h	g	t	d1	d2	d3	c	m			
ZMV 17	M 17 × 1	28	15	4	2.5	23	22.5	3.3	10	M4	49	7	24
ZMV 20	M 20 × 1	32	15	4	3	25	26	3.3	10	M4	55	7	34
ZMV 25	M 25 × 1.5	38	17	5	3	31	31.5	4.2	11	M5	87	7	54
ZMV 30	M 30 × 1.5	45	17	5	3	38	37.5	4.2	11	M5	110	7	76
ZMV 35	M 35 × 1.5	52	17	5	3	45	43.5	4.2	11	M5	120	7	102
ZMV 40	M 40 × 1.5	58	19	6	3	50	49	5	12	M6	150	7	144
ZMV 45	M 45 × 1.5	65	19	6	3	56	55	5	12	M6	170	7	180
ZMV 50	M 50 × 1.5	70	19	6	3	61	60	5	12	M6	180	7	196
ZMV 55	M 55 × 2	75	21	7	4	66	65	5	13	M6	250	18	240
ZMV 60	M 60 × 2	80	21	7	4	70	70	5	13	M6	270	18	262
ZMV 65	M 65 × 2	85	21	7	4	76	75	5	13	M6	290	18	282
ZMV 70	M 70 × 2	92	23	8	4	82	81	6.2	14	M8	350	18	378
ZMV 75	M 75 × 2	98	23	8	4	87	87	6.2	14	M8	370	18	422
ZMV 80	M 80 × 2	105	23	8	4	92	93	6.2	14	M8	390	18	492
ZMV 85	M 85 × 2	110	23	8	4	99	98	6.2	14	M8	400	34	524
ZMV 90	M 90 × 2	120	25	10	4	105	105	6.2	15	M8	470	34	750
ZMV 95	M 95 × 2	125	25	10	4	110	110	6.2	15	M8	490	34	782
ZMV 100	M 100 × 2	130	25	10	4	116	115	6.2	15	M8	510	34	826
ZMV 105	M 105 × 2	140	27	12	5	122	123	7.9	16	M10	560	34	1,108
ZMV 110	M 110 × 2	145	27	12	5	129	128	7.9	16	M10	600	34	1,164
ZMV 120	M 120 × 2	155	29	12	5	136	138	7.9	17	M10	710	34	1,378
ZMV 130	M 130 × 2	165	29	12	5	137	148	7.9	17	M10	760	34	1,480
ZMV 140	M 140 × 2	180	31	14	6	156	160	9.6	18	M12	880	60	1,958
ZMV 150	M 150 × 2	195	31	14	6	167	173	9.6	18	M12	930	60	2,404
ZMV 160	M 160 × 3	210	33	16	7	178	185	9.6	19	M12	980	60	3,080
ZMV 170	M 170 × 3	220	33	16	7	189	195	9.6	19	M12	1,130	60	3,256
ZMV 180	M 180 × 3	230	35	18	8	199	205	9.6	20	M12	1,300	60	3,628
ZMV 190	M 190 × 3	240	35	18	8	210	215	9.6	20	M12	1,470	60	3,928
ZMV 200	M 200 × 3	250	37	18	8	222	225	9.6	21	M12	1,600	60	4,330

## SLN Type

### Features

- ▶ Material : DIN C45, JIS S45C, KS S45C
- ▶ Hardness : HRC 22~25
- ▶ Nut Grade : Precision class
- ▶ Squareness of Nut Face :  $\pm 0.007$

### Advantages

1. Three locking pins located in equal intervals enable the nut to be assembled with the shaft at appropriate angle and adjust the deviation properly.
2. No need for a lock washer or fluting of shaft key.

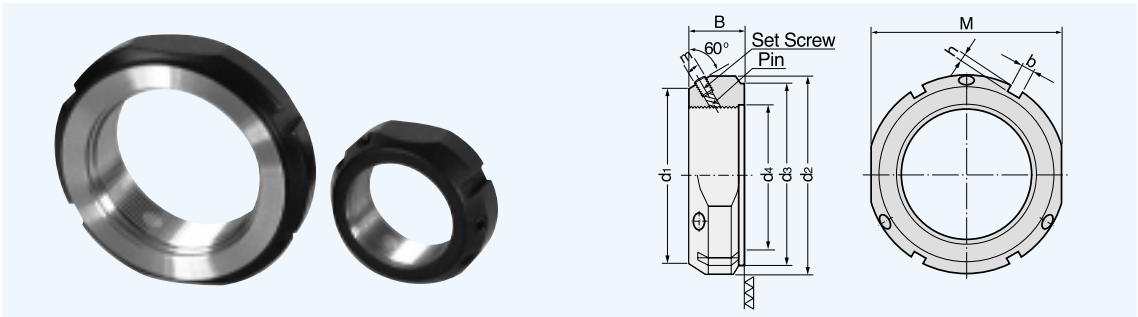

Dimension :mm

PART NO	THREAD & FITCH	Dimensions										Axial Load (KN)	Weight (kg)
		d1	d2	d3	d4	B	b	Set Screw					
								h	M	m	Toque(Nm)		
SLN 02	M 15 × 1	26	33	25	16	16	4	2.5	30	M5	4.5	60	0.075
SLN 03	M 17 × 1	29	37	30	18	18	5	2.5	34	M6	8	80	0.1
SLN 04	M 20 × 1	32	40	32	21	18	5	2.5	36	M6	8	90	0.11
SLN 05	M 25 × 1.5	36	44	36	26	20	5	2.5	41	M6	8	130	0.13
SLN 06	M 30 × 1.5	41	49	41	32	20	5	2.5	46	M6	8	160	0.16
SLN 07	M 35 × 1.5	46	54	46	38	22	5	2.5	50	M6	8	190	0.19
SLN 08	M 40 × 1.5	56	65	56	42	22	6	3	80	M6	8	210	0.30
SLN 09	M 45 × 1.5	61	70	61	48	22	6	3	65	M6	8	240	0.33
SLN 10	M 50 × 1.5	65	75	65	52	25	7	3	70	M6	8	300	0.40
SLN 11	M 55 × 2	74	85	75	58	26	7	3	80	M8	18	340	0.54
SLN 12	M 60 × 2	78	90	79	62	28	8	4	85	M8	18	380	0.61
SLN 13	M 65 × 2	83	95	84	68	28	8	4	90	M8	18	460	0.71
SLN 14	M 70 × 2	88	100	89	72	28	8	4	95	M8	18	490	0.75
SLN 15	M 75 × 2	93	110	94	77	32	8	4	100	M8	18	520	0.80
SLN 16	M 80 × 2	98	115	96	83	32	8	4	105	M8	18	620	0.90
SLN 17	M 85 × 2	107	120	106	88	32	10	4	115	M10	35	650	1.15
SLN 18	M 90 × 2	112	125	111	93	32	10	4	120	M10	35	680	1.20
SLN 19	M 95 × 2	117	130	116	98	32	10	4	125	M10	35	710	1.25
SLN 20	M 100 × 2	122	135	121	103	32	10	4	130	M10	35	740	1.3
SLN 22	M 110 × 2	132	145	130	112	32	10	4	140	M10	35	800	1.45
SLN 24	M 120 × 2	142	155	140	122	32	10	4	150	M10	35	860	1.6
SLN 26	M 130 × 2	152	165	150	132	32	12	5	160	M10	35	920	1.7
SLN 28	M 140 × 2	162	175	160	142	32	14	6	170	M10	35	980	1.8
SLN 30	M 150 × 2	172	185	170	152	32	14	6	180	M10	35	1,040	1.95
SLN 32	M 160 × 3	182	195	180	162	32	14	6	—	M10	35	1,100	2.1
SLN 34	M 170 × 3	192	205	190	172	32	14	6	—	M10	35	1,160	2.2
SLN 36	M 180 × 3	202	215	200	182	32	16	7	—	M10	35	1,220	2.3
SLN 38	M 190 × 3	212	224	214	192	32	16	7	—	M10	35	1,280	2.4
SLN 40	M 200 × 3	222	235	220	202	32	18	8	—	M10	35	1,340	2.5

## SWLN Type

### Features

- ▶ Material : DIN C45, JIS S45C, KS S45C
- ▶ Hardness : HRC 22~25
- ▶ Nut Grade : Precision class
- ▶ Squareness of Nut Face :  $\pm 0.007$

### Advantages

1. Three locking pins located in equal intervals enable the nut to be assembled with the shaft at appropriate angle and adjust the deviation properly.
2. No need for a lock washer or fluting of shaft key.

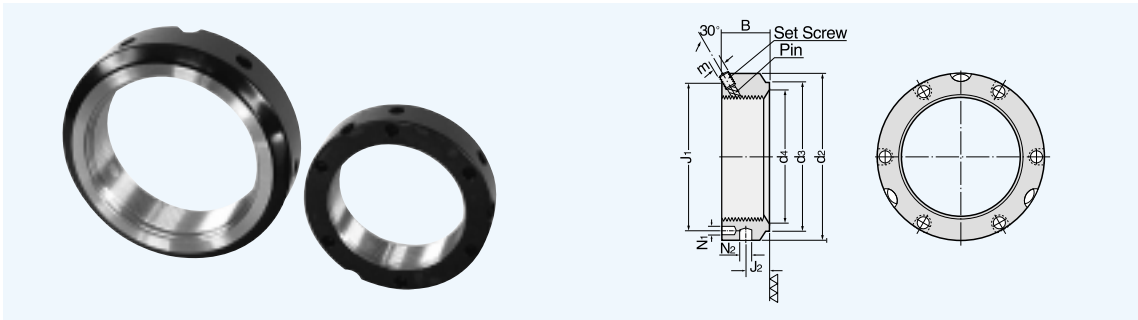

Dimension:mm

PART NO	THREAD & PITCH	Dimensions										Axial Load (KN)	Weight (kg)
		d2	d3	d4	B	J1	J2	N1	N2	Set Screw			
										m	Torque(Nm)		
SWLN04	M 20 × 1.0	38	30	21	18	29	10	4.3	4	M6	8		
SWLN05	M 25 × 1.5	42	35	26	20	32.5	11	4.3	4	M6	8	130	0.12
SWLN06	M 30 × 1.5	48	40	32	20	40.5	11	4.3	5	M6	8	160	0.15
SWLN07	M 35 × 1.5	53	47	38	20	45.5	11	4.3	5	M6	8	190	0.18
SWLN08	M 40 × 1.5	58	52	42	22	50.5	12	4.3	5	M6	8	210	0.21
SWLN09	M 45 × 1.5	68	58	48	22	58	12	4.3	6	M6	8	240	0.30
SWLN10	M 50 × 1.5	70	63	52	24	61.5	13	4.3	6	M6	8	300	0.31
SWLN11	M 55 × 1.5	75	70	58	24	66.5	13	4.3	6	M6	8	340	0.35
SWLN12	M 60 × 1.5	84	75	62	24	74.5	13	5.3	6	M6	8	380	0.45
SWLN13	M 65 × 1.5	88	80	68	25	78.5	13	5.3	6	M6	8	460	0.48
SWLN14	M 70 × 1.5	95	86	72	26	85	14	5.3	8	M8	18	490	0.57
SWLN15	M 75 × 1.5	100	91	77	26	88	13	5.3	8	M8	18	520	0.61
SWLN16	M 80 × 2	110	97	83	30	95	16	5.3	8	M8	18	620	0.91
SWLN17	M 85 × 2	115	102	88	32	100	17	6.4	8	M10	35	650	1.05
SWLN18	M 90 × 2	120	110	93	32	108	17	6.4	8	M10	35	680	1.10
SWLN19	M 95 × 2	125	114	98	32	113	17	6.4	8	M10	35	710	1.15
SWLN20	M 100 × 2	130	120	103	32	118	17	6.4	8	M10	35	740	1.20
SWLN22	M 110 × 2	140	132	112	32	128	17	6.4	8	M10	35	800	1.35
SWLN24	M 120 × 2	155	142	122	32	140	17	6.4	8	M10	35	860	1.70
SWLN26	M 130 × 3	165	156	132	32	153	17	6.4	8	M10	35	920	1.90
SWLN28	M 140 × 3	180	166	142	32	165	17	6.4	10	M10	35	980	2.25
SWLN30	M 150 × 3	190	180	152	32	175	17	6.4	10	M10	35	1,040	2.45
SWLN32	M 160 × 3	205	191	162	32	185	17	6.4	10	M10	35	1,100	2.90
SWLN34	M 170 × 3	215	205	172	32	195	17	8.4	10	M10	35	1,160	3.15
SWLN36	M 180 × 3	230	215	182	32	210	17	8.4	10	M10	35	1,220	3.65
SWLN38	M 190 × 3	240	225	192	32	224	17	8.4	10	M10	35	1,280	3.85
SWLN40	M 200 × 3	245	237	202	32	229	17	8.4	10	M10	35	1,340	3.70

## YHB Type

### Features

- ▶ Material : DIN C45, JIS S45C, KS S45C
- ▶ Hardness : HRC 22~25
- ▶ Nut Grade : Precision class
- ▶ Squareness of Nut Face :  $\pm 0.007$

### Advantages

1. Thanks to enhanced flatness and roughness of reference plane by lapping work, YHB type fits in shaft build-up which requires high fixing degree.
2. Three locking pins located in equal intervals enable the nut to be assembled with the shaft exactly at appropriate angle and adjust the deviation properly.
3. Keeps a good balance thanks to the equal interval fluting of lock pin and hook spanner.

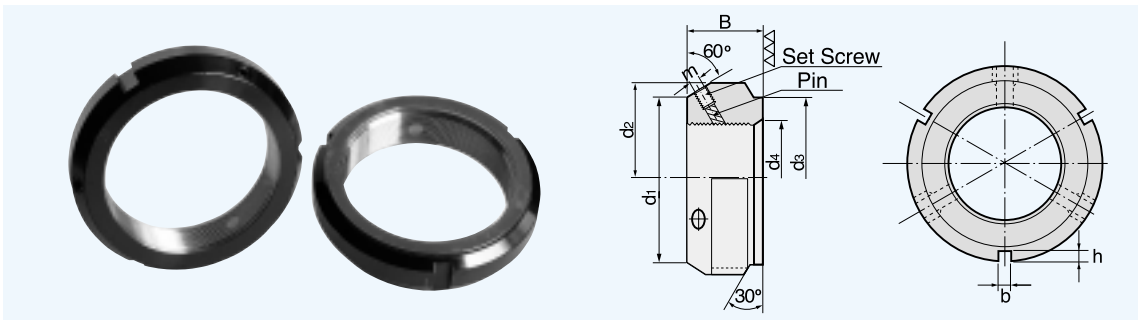

Dimension:mm

PART NO	THREAD & PITCH	Dimensions								Axial Load (KN)	Set Screw (N m)	Weight (g)
		d1	d2	d3	d4	B	b	h	m			
YHB 02	M 15 × 1	26	33	25	16	16	4	2.5	M5	60	8	0.085
YHB 03	M 17 × 1	29	37	30	18	18	5	2.5	M6	80	8	0.11
YHB 04	M 20 × 1	32	40	32	21	18	5	2.5	M6	90	8	0.12
YHB 05	M 25 × 1.5	38	44	36	26	20	5	2.5	M6	130	8	0.14
YHB 06	M 30 × 1.5	41	49	41	32	20	5	2.5	M6	160	8	0.18
YHB 07	M 35 × 1.5	46	54	46	38	22	5	2.5	M6	210	8	0.21
YHB 08	M 40 × 1.5	56	65	56	42	22	6	3	M6	240	8	0.33
YHB 09	M 45 × 1.5	61	70	61	48	22	6	3	M6	300	8	0.37
YHB 10	M 50 × 1.5	65	75	65	52	25	7	3	M6	340	8	0.45
YHB 11	M 55 × 2	74	85	75	58	25	7	3	M8	380	18	0.59
YHB 12	M 60 × 2	78	90	79	62	26	8	4	M8	460	18	0.67
YHB 13	M 65 × 2	83	95	84	68	28	8	4	M8	490	18	0.78
YHB 14	M 70 × 2	88	100	89	72	28	8	4	M8	520	18	0.83
YHB 15	M 75 × 2	93	105	94	77	28	8	4	M8	620	18	0.88
YHB 16	M 80 × 2	98	110	96	83	32	8	4	M8	650	18	0.99
YHB 17	M 85 × 2	107	120	106	88	32	10	4	M10	680	35	1.27
YHB 18	M 90 × 2	112	125	111	93	32	10	4	M10	710	35	1.32
YHB 19	M 95 × 2	117	130	116	98	32	10	4	M10	740	35	1.38
YHB 20	M 100 × 2	122	135	121	103	32	10	4	M10	800	35	1.43
YHB 22	M 110 × 2	132	145	130	112	32	10	4	M10	860	35	1.60
YHB 24	M 120 × 2	142	155	140	122	32	10	4	M10	920	35	1.76
YHB 26	M 130 × 2	152	165	150	132	32	12	5	M10	980	35	1.87
YHB 28	M 140 × 2	162	175	160	142	32	14	6	M10	1,040	35	1.98
YHB 30	M 150 × 2	172	185	170	152	32	14	6	M10	1,100	35	2.15
YHB 32	M 160 × 2	182	195	180	162	32	14	6	M10	1,160	35	2.35
YHB 34	M 170 × 2	192	205	190	172	32	14	6	M10	1,220	35	2.55
YHB 36	M 180 × 2	202	215	200	182	32	16	7	M10	1,280	35	2.64
YHB 40	M 200 × 2	222	235	220	202	32	18	8	M10	1,340	35	2.85



## HB Type

### Features

- ▶ Material : DIN C45, JIS S45C, KS S45C
- ▶ Hardness : HRC 22~25
- ▶ Nut Grade : Precision class
- ▶ Squareness of Nut Face :  $\pm 0.007$

### Advantages

1. Thanks to enhanced flatness and roughness of reference plane by lapping work, HB type fits in shaft build-up which requires high fixing degree.
2. Three locking pins located in equal intervals enable the nut to be assembled with the shaft exactly at appropriate angle and adjust the deviation properly.
3. Keeps a good balance thanks to the equal interval fluting of lock pin and hook spanner.

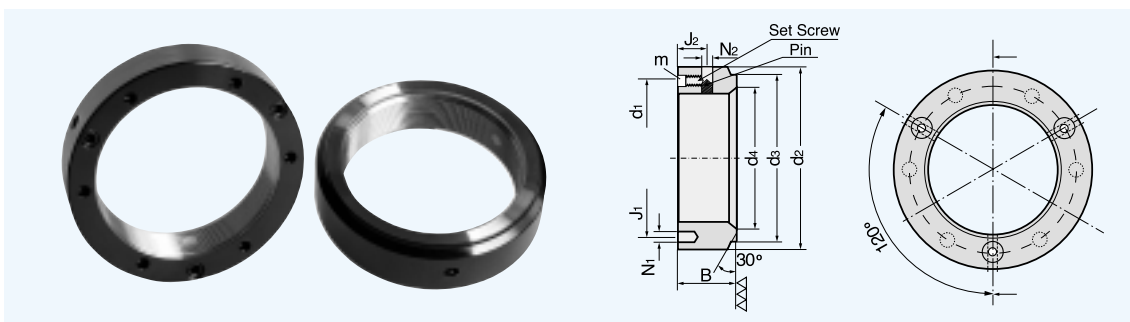

Dimension :mm

PART NO	THREAD & PITCH	Dimensions										Axial Load (KN)	Set Screw (N m)	Weight (g)
		d1	d2	d3	d4	B	J1	J2	N1	N2	m			
HB 05	M 25 × 1.5	33.5	42	35	26	20	32.5	11	4.3	5	M6	130	8	0.12
HB 06	M 30 × 1.5	39	48	40	32	20	40.5	11	4.3	5	M6	160	8	0.15
HB 07	M 35 × 1.5	44	53	47	38	20	45.5	11	4.3	5	M6	190	8	0.18
HB 08	M 40 × 1.5	49	58	52	42	22	50.5	12	4.3	5	M6	210	8	0.21
HB 09	M 45 × 1.5	56.5	68	58	48	22	58	12	4.3	5	M6	240	8	0.30
HB 10	M 50 × 1.5	60	70	63	52	24	61.5	12	4.3	5	M6	300	8	0.31
HB 11	M 55 × 1.5	65	75	70	58	24	66.5	13	4.3	5	M6	340	8	0.35
HB 12	M 60 × 1.5	72	84	75	62	24	74.5	13	5.3	5	M6	380	8	0.45
HB 13	M 65 × 1.5	76	88	80	68	25	78.5	13	5.3	5	M6	460	8	0.48
HB 14	M 70 × 1.5	83	95	86	72	26	85	14	5.3	7.9	M10	490	18	0.57
HB 15	M 75 × 1.5	88	100	91	77	26	88	13	6.4	7.9	M10	520	18	0.61
HB 16	M 80 × 2	96	110	97	83	30	95	16	6.4	7.9	M10	620	18	0.91
HB 17	M 85 × 2	100	115	102	88	32	100	17	6.4	9.6	M12	650	35	1.05
HB 18	M 90 × 2	105	120	110	93	32	108	17	6.4	9.6	M12	680	35	1.10
HB 19	M 95 × 2	110	125	114	98	32	113	17	6.4	9.6	M12	710	35	1.15
HB 20	M 100 × 2	115	130	120	103	32	118	17	6.4	9.6	M12	740	35	1.20
HB 22	M 110 × 2	128	140	132	112	32	128	17	6.4	9.6	M12	800	35	1.35
HB 24	M 120 × 2	138	155	142	122	32	140	17	6.4	9.6	M12	860	35	1.70
HB 26	M 130 × 3	148	165	156	132	32	153	17	6.4	9.6	M12	920	35	1.90
HB 28	M 140 × 3	160	180	166	142	32	165	17	6.4	9.6	M12	980	35	2.25
HB 30	M 150 × 3	173	195	180	152	32	175	17	6.4	9.6	M12	1,040	35	2.45
HB 32	M 160 × 3	182	205	190	162	32	185	17	8.4	9.6	M12	1,100	35	2.90
HB 34	M 170 × 3	192	215	205	172	32	195	17	8.4	9.6	M12	1,160	35	3.15
HB 36	M 180 × 3	205	230	215	182	32	210	17	8.4	9.6	M12	1,220	35	3.65
HB 38	M 190 × 3	215	245	225	192	32	224	17	8.4	9.6	M12	1,280	35	3.85
HB 40	M 200 × 3	223	245	237	202	32	229	17	8.4	9.6	M12	1,340	35	3.70



## MSR Type

### Features

- ▶ Material : DIN C45, JIS S45C, KS S45C
- ▶ Hardness : HRC 22~25
- ▶ Nut Grade : Precision class
- ▶ Squareness of Nut Face :  $\pm 0.007$

### Advantages

1. Preload and tension can be adjusted.
2. Tolerative with vibration. (shake, oscillation)

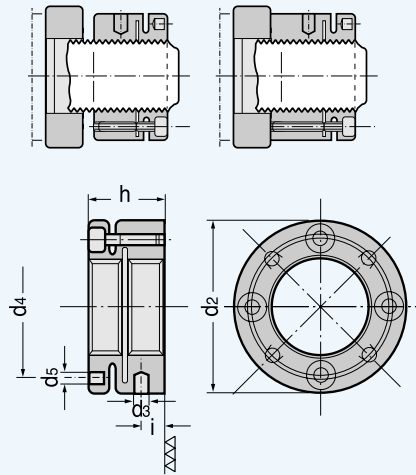
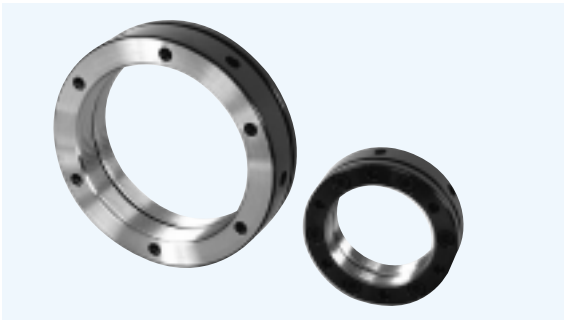

Dimension: mm

PART NO	Dimensions						Holes	Tight bolt			Axial Load (KN)	Set Screw (N m)	Weight (g)
	d2	d3	d4	d5	h	i		Thread & Length	Bolts	Torque(kgf.m)			
MSR 16 × 1.5	34	4	24.5	4.3	18	5	4	M4 × 12	4	0.29	340	0.29	80
MSR 18 × 1.5	36	4	26.5	4.3	18	5	4	M4 × 12	4	0.29	370	0.29	87
MSR 20 × 1.5	40	4	30.5	4.3	18	5	4	M4 × 12	4	0.29	400	0.29	107
MSR 22 × 1.5	40	4	30.5	4.3	18	5	4	M4 × 12	4	0.29	420	0.29	100
MSR 24 × 1.5	42	4	32.5	4.3	18	5	4	M4 × 12	4	0.29	440	0.29	107
MSR 25 × 1.5	45	5	36.5	4.3	20	6.5	4	M4 × 12	4	0.29	450	0.29	137
MSR 28 × 1.5	46	5	38.5	4.3	20	6.5	4	M4 × 12	4	0.29	480	0.29	136
MSR 30 × 1.5	48	5	40.5	4.3	20	6.5	4	M4 × 12	4	0.29	500	0.29	141
MSR 32 × 1.5	50	5	42.5	4.3	22	7	4	M4 × 16	4	0.29	520	0.29	163
MSR 35 × 1.5	53	5	45.5	4.3	22	7	4	M4 × 16	4	0.29	550	0.29	175
MSR 38 × 1.5	58	5	48.5	4.3	22	7	4	M4 × 16	4	0.29	580	0.29	212
MSR 40 × 1.5	58	5	50.5	4.3	22	7	4	M4 × 16	4	0.29	600	0.29	195
MSR 42 × 1.5	60	5	52.5	4.3	22	7	4	M4 × 16	4	0.29	620	0.29	204
MSR 45 × 1.5	68	6	58	4.3	22	6.5	6	M4 × 16	6	0.29	1,070	0.29	288
MSR 48 × 1.5	68	6	59.5	4.3	25	9	6	M4 × 18	6	0.29	1,180	0.29	294
MSR 50 × 1.5	70	6	61.5	4.3	25	9	6	M4 × 18	6	0.29	1,250	0.29	303
MSR 52 × 1.5	70	6	63.5	4.3	25	9	6	M4 × 18	6	0.29	1,300	0.29	314
MSR 55 × 1.5	75	6	66.5	4.3	25	9	6	M4 × 18	6	0.29	1,410	0.29	327
MSR 58 × 1.5	82	6	72.5	5.3	28	9	6	M5 × 18	6	0.6	2,100	0.6	446
MSR 60 × 1.5	84	6	74.5	5.3	28	9	6	M5 × 18	6	0.6	2,200	0.6	479
MSR 62 × 1.5	86	6	76.5	5.3	28	10.5	6	M5 × 20	6	0.6	2,310	0.6	505
MSR 65 × 1.5	88	6	78.5	5.3	28	10.5	6	M5 × 20	6	0.6	2,470	0.6	500
MSR 68 × 1.5	95	8	83	5.3	28	9.5	6	M5 × 20	6	0.6	2,620	0.6	625
MSR 70 × 1.5	95	8	85	5.3	28	9.5	6	M5 × 20	6	0.6	2,730	0.6	536
MSR 72 × 1.5	98	8	86	6.4	28	8.5	6	M6 × 20	6	1.0	3,640	1.0	626
MSR 75 × 1.5	100	8	88	6.4	28	8.5	6	M6 × 20	6	1.0	3,750	1.0	623
MSR 80 × 2	110	8	95	6.4	32	11	6	M6 × 22	6	1.0	3,900	1.0	890
MSR 85 × 2	115	8	100	6.4	32	11	6	M6 × 22	6	1.0	4,000	1.0	963
MSR 90 × 2	120	8	108	6.4	32	11	6	M6 × 22	6	1.0	4,200	1.0	1,020
MSR 95 × 2	125	8	113	6.4	32	11	6	M6 × 22	6	1.0	4,350	1.0	1,050
MSR 100 × 2	130	8	118	6.4	32	11	6	M6 × 22	6	1.0	4,500	1.0	1,100
MSR 105 × 2	135	8	123	6.4	32	11	6	M6 × 22	6	1.0	4,650	1.0	1,150
MSR 110 × 2	140	8	128	6.4	32	11	6	M6 × 22	6	1.0	4,800	1.0	1,210
MSR 115 × 2	145	8	133	6.4	36	13	6	M6 × 25	6	1.0	4,950	1.0	1,430
MSR 120 × 2	155	8	140	6.4	36	13	6	M6 × 25	6	1.0	5,100	1.0	1,740
MSR 125 × 2	160	8	148	6.4	36	13	6	M6 × 25	6	1.0	5,250	1.0	1,820
MSR 130 × 3	165	8	153	6.4	36	13	6	M6 × 25	6	1.0	5,450	1.0	1,940
MSR 140 × 3	180	10	165	6.4	36	12	8	M6 × 25	8	1.0	5,700	1.0	2,335
MSR 150 × 3	190	10	175	6.4	36	12	8	M6 × 25	8	1.0	6,000	1.0	2,480
MSR 160 × 3	205	10	185	8.4	40	14	8	M8 × 30	8	2.5	6,300	2.5	3,380
MSR 170 × 3	215	10	195	8.4	40	14	8	M8 × 30	8	2.5	6,650	2.5	3,580
MSR 180 × 3	230	10	210	8.4	40	14	8	M8 × 30	8	2.5	7,000	2.5	4,110
MSR 190 × 3	240	10	224	8.4	40	14	8	M8 × 30	8	2.5	7,300	2.5	4,330
MSR 200 × 3	245	10	229	8.4	40	14	8	M8 × 30	8	2.5	7,600	2.5	4,410



## LOCKING ELEMENT

Would you like to change your drawing ?

No need for key, washer, double nut,  
No need for key, key home working for boss and shaft.

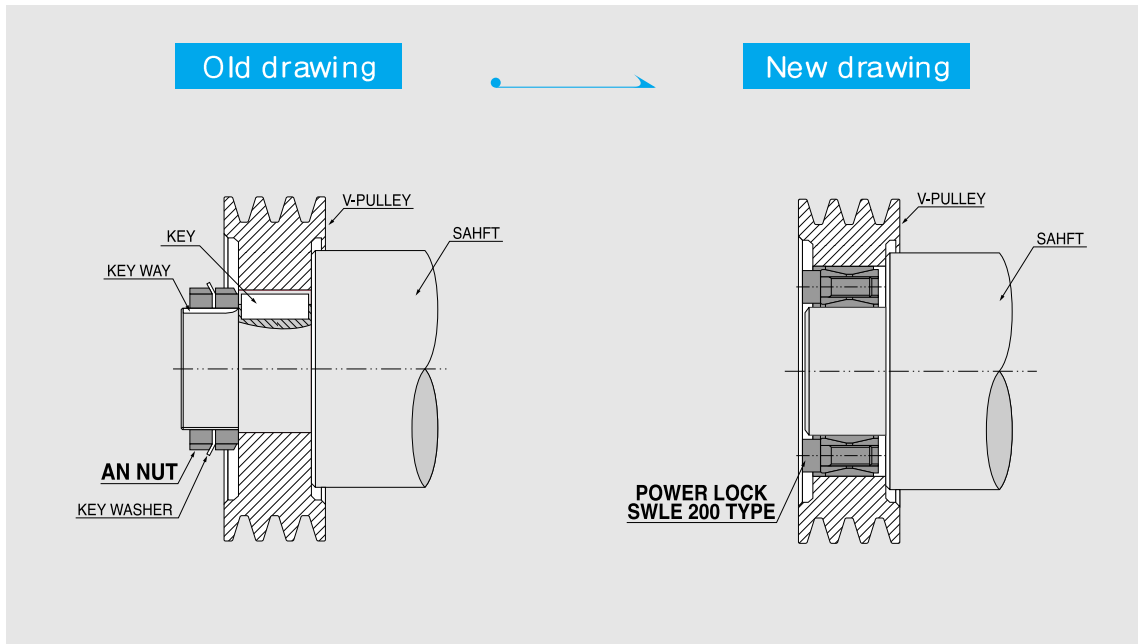

Old drawing



New drawing

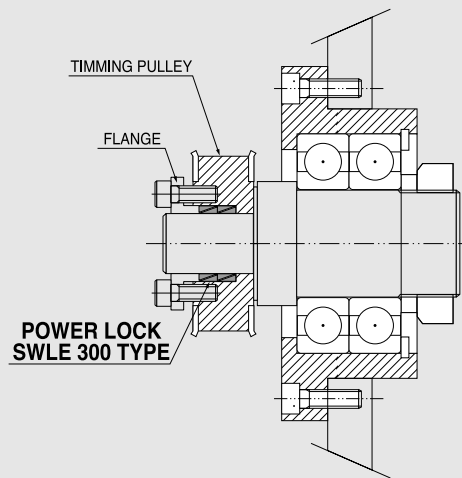
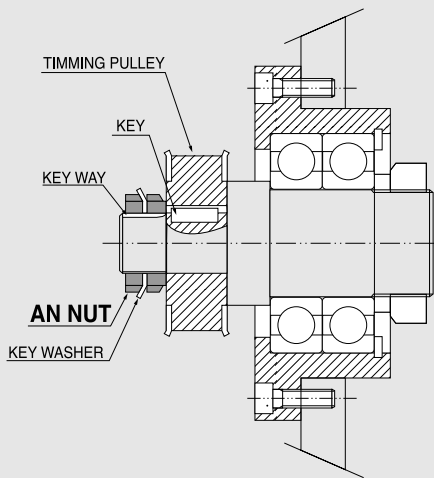

## SWLE 100 Type

### Characteristics

- ▶ Medium–high torque
- ▶ Limited installation time
- ▶ Restricted hub diameter
- ▶ Very low surface presste

### Features

- ▶ Material : DIN C45, JIS S45C, KS SM45C
- ▶ Hardness : HRC 22~25
- ▶ Surface treatment : Barrel grinding



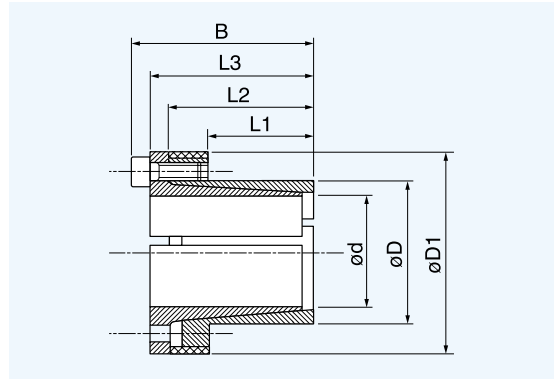
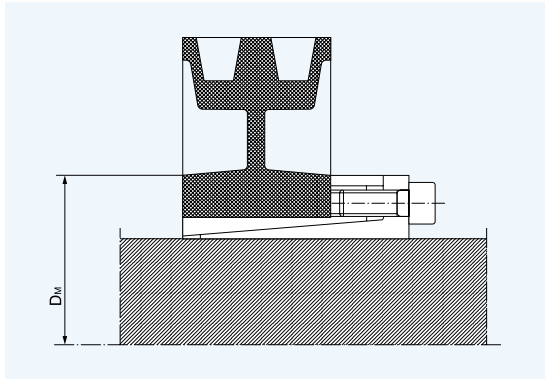

SWLE 100 d x D	L1	L2	L3	B	D1	Torque	Axial Thrust Fass.	Surface pressure on		Tightening screws		Weight
								Shaft Pw	Hub Pn	DIN 912 12.9	Tightening torque Ms	
						Nm	KN	N/mm <sup>2</sup>	N/mm <sup>2</sup>	No. x type	Nm	g
12 × 18	14	23	26	30	32	58	10	160	105	4 × M4	5	80
13 × 23	14	23	26	30	38	63	10	140	80	4 × M4	5	125
14 × 23	14	23	26	30	38	68	10	130	80	4 × M4	5	120
15 × 24	16	29	36	42	45	127	17	185	115	3 × M6	17	257
16 × 24	16	29	36	42	45	136	17	175	115	3 × M6	17	250
17 × 26	18	31	38	44	47	180	22	190	125	4 × M6	17	280
18 × 26	18	31	38	44	47	200	22	180	125	4 × M6	17	270
19 × 27	18	31	38	44	49	210	22	170	120	4 × M6	17	290
20 × 28	18	31	38	44	50	220	22	160	115	4 × M6	17	300
22 × 32	25	38	45	51	54	250	22	115	80	4 × M6	17	385
24 × 34	25	38	45	51	56	270	22	105	75	4 × M6	17	405
25 × 34	25	38	45	51	56	280	22	100	75	4 × M6	17	390
28 × 39	25	38	45	51	61	465	33	135	97	6 × M6	17	475
30 × 41	25	38	45	51	62	510	33	127	90	6 × M6	17	480
32 × 43	25	38	45	51	65	540	33	120	90	6 × M6	17	520
35 × 47	32	45	52	58	69	790	45	105	80	8 × M6	17	630
38 × 50	32	45	52	58	72	860	45	100	75	8 × M6	17	670
40 × 53	32	45	52	58	75	900	45	95	70	8 × M6	17	735
42 × 55	32	45	52	58	78	950	45	90	70	8 × M6	17	780
45 × 59	45	62	70	78	86	1890	84	110	85	8 × M8	41	1,230
48 × 62	45	62	70	78	87	2010	84	105	80	8 × M8	41	1,240
50 × 65	45	62	70	78	92	2100	84	100	75	8 × M8	41	1,400
55 × 71	55	72	80	88	98	2600	94	85	65	9 × M8	41	1,700
60 × 77	55	72	80	88	104	2840	94	75	60	9 × M8	41	1,950
65 × 84	55	72	80	88	111	3070	94	70	55	9 × M8	41	2,200
70 × 90	65	86	96	106	119	5250	150	90	70	9 × M10	83	3,050
75 × 95	65	86	96	106	126	5600	150	80	65	9 × M10	83	3,300
80 × 100	65	86	96	106	131	8020	200	100	80	12 × M10	83	3,500
85 × 106	65	86	96	106	137	8500	200	95	75	12 × M10	83	3,800
90 × 112	65	86	96	106	144	9000	200	90	75	12 × M10	83	4,200
95 × 120	65	86	96	106	149	11000	230	100	80	14 × M10	83	4,750
100 × 125	65	86	96	106	154	15000	300	120	95	12 × M12	83	4,880
110 × 140	90	114	128	140	180	16000	290	80	65	12 × M12	145	8,950
120 × 155	90	114	128	140	198	17500	290	70	55	12 × M12	145	11,500
130 × 165	90	114	128	140	208	25000	384	90	70	16 × M12	145	12,100



## SWLE 200 Type

### Advantages

- ▶ SWLE200 can be used in connecting the shaft and boss when it requires a high transfer torque.
- ▶ Easy assembling and no need for other parts.
- ▶ Required shaft :  $\varnothing 20 \sim \varnothing 240\text{mm}$

### Usage

- ▶ Pulley, gear, flywheel, cam, lever etc.

### Features

- ▶ Material : DIN C45, JIS S45C, KS S45C
- ▶ Hardness : HRC 22~25
- ▶ Surface treatment : Barrel grinding



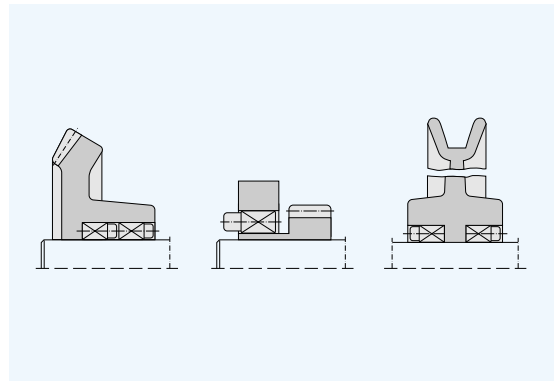
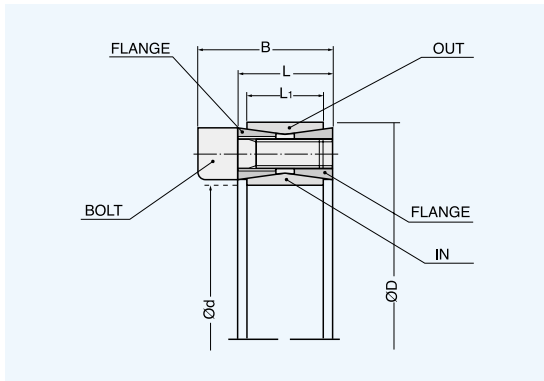

SWLE 100 d x D	Dimensions			Axial Load		Surface Pressure		Bolt			Weight (g)
	L1	L2	B	Torque Mt(kgf-m)	Axial Load Pax(kgf)	Shaft kgf/mm <sup>2</sup>	Boss kgf/mm <sup>2</sup>	Holes	Thread Dia	Torque kgf-m	
20 × 47	20	17	27	27	2760	27	11	8	M 6	1.4	208
22 × 47	20	17	27	30	2760	24.5	11.5	8	M 6	1.4	198
24 × 50	20	17	27	37	3110	25	12	9	M 6	1.4	216
25 × 50	20	17	27	39	3110	24	12	9	M 6	1.4	210
28 × 55	20	17	27	48	3450	24	12	10	M 6	1.4	256
30 × 55	20	17	27	52	3460	22.5	12.5	10	M 6	1.4	244
32 × 60	20	17	27	66	4150	25	13.5	12	M 6	1.4	294
35 × 60	20	17	27	72	4150	23	13.5	12	M 6	1.4	276
38 × 65	20	17	27	91	4840	25	14.5	14	M 6	1.4	320
40 × 65	20	17	27	96	4840	23.5	14.5	14	M 6	1.4	308
42 × 75	24	20	33	158	7520	30	17	12	M 8	3.4	556
45 × 75	42	20	33	170	7520	28	17	12	M 8	3.4	522
48 × 80	24	20	33	181	7520	26	15.5	12	M 8	3.4	578
50 × 80	24	20	33	190	7520	25	15.5	12	M 8	3.4	564
55 × 85	24	20	33	242	8800	26.5	17	14	M 8	3.4	610
60 × 90	24	20	33	264	8800	24.5	16	14	M 8	3.4	644
65 × 95	24	20	33	327	10000	26	17.5	16	M 8	3.4	690
70 × 110	28	24	39	480	13600	27	17	14	M 10	6.6	1,214
75 × 115	28	24	39	510	13600	25	16.5	14	M 10	6.6	1,280
80 × 120	28	24	39	540	13600	24	16	14	M 10	6.6	1,346
85 × 125	28	24	39	660	15600	25.5	17.5	16	M 10	6.6	1,424
90 × 130	28	24	39	700	15600	24	16.5	16	M 10	6.6	1,472
95 × 135	28	24	39	830	17600	25.5	18	18	M 10	6.6	1,546
100 × 145	33	26	47	990	19800	25.5	17.5	14	M 12	11.5	2,132
110 × 155	33	26	47	1090	19800	23	16.5	14	M 12	11.5	2,306
120 × 165	33	26	47	1360	22700	24	17.5	16	M 12	11.5	2,400
130 × 180	38	34	52	1840	28400	21.5	15.5	20	M 12	11.5	3,500
140 × 190	38	34	52	2180	31200	22	16	22	M 12	11.5	3,848
150 × 200	38	34	52	2550	34000	22	16.5	24	M 12	11.5	4,100
160 × 210	38	34	52	2950	36900	22.5	17	26	M 12	11.5	4,400
170 × 225	44	38	60	3560	41900	21.5	16.5	22	M 14	18.0	5,800
180 × 235	44	38	60	4110	45700	22	17	24	M 14	18.0	6,100
190 × 250	52	46	68	5060	53300	20	15.5	28	M 14	18.0	8,300
200 × 260	52	46	68	5710	57100	20.5	16	30	M 14	18.0	8,700
220 × 285	56	50	74	7410	67400	20.5	15.5	26	M 16	28.0	11,300
240 × 305	56	50	74	9330	77800	21.5	17	30	M 16	28.0	12,200



## SWLE 200-A Type

### Advantages

- ▶ SWLE200-A applies to high transfer torque and precise positioning.
- ▶ No axial shift while assembling.
- ▶ Required shaft :  $\varnothing 19 \sim \varnothing 100 \text{mm}$

### Usage

- ▶ Pulley, gear, flywheel, cam, lever etc.

### Features

- ▶ Material : JIS S45C, KS SCM440, BS 708H42
- ▶ Hardness : HRC 22~25
- ▶ Surface treatment : Barrel grinding





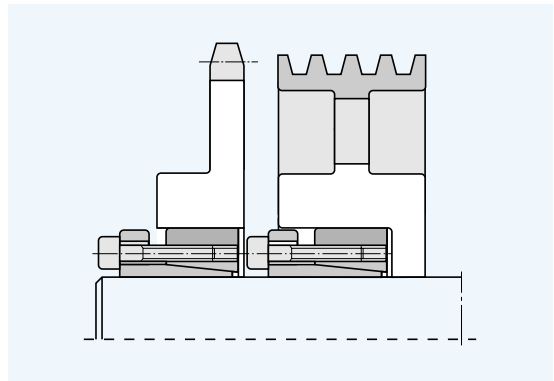
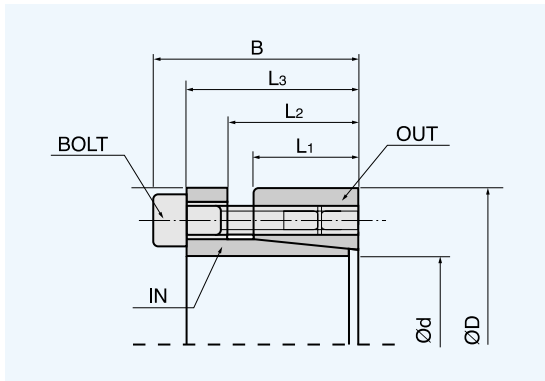

SWLE 100 d x D	Dimensions					Clamp Bolt			Axial Load		Surface Pressure		Weight (g)	
	B	L3	L2	L1	D	D1	Holes	Thread	Torque	Torque Mt (kgf-m)	Axial Load Pax (kgf)	Shaft kgf/mm <sup>2</sup>		Boss kgf/mm <sup>2</sup>
19 × 47	38	32	24	20	47	53	6	M6 × 22	1.6	30	3,100	30.4	9.8	325
20 × 47	38	32	24	20	47	53	6	M6 × 22	1.6	31	3,100	28.8	9.8	315
22 × 47	38	32	24	20	47	53	6	M6 × 22	1.6	34	3,100	26.2	9.8	305
24 × 50	38	32	24	20	50	56	7	M6 × 22	1.6	47	3,900	30.0	11.5	345
25 × 50	38	32	24	20	50	56	7	M6 × 22	1.6	49	3,900	28.8	11.5	335
28 × 55	38	32	24	20	55	62	7	M6 × 22	1.6	55	3,900	25.7	10.5	395
30 × 55	38	32	24	20	55	62	7	M6 × 22	1.6	59	3,900	24.0	10.5	375
32 × 60	38	32	24	20	60	68	9	M6 × 22	1.6	75	4,650	27.0	11.5	455
35 × 60	38	32	24	20	60	68	9	M6 × 22	1.6	82	4,650	24.7	11.5	420
38 × 65	38	32	24	20	65	73	9	M6 × 22	1.6	89	4,650	22.7	10.6	490
40 × 65	38	32	24	20	65	73	9	M6 × 22	1.6	93	4,650	21.6	10.6	465
42 × 75	48	40	29	24	75	83	9	M8 × 30	3.9	181	8,600	31.9	14.2	855
45 × 75	48	40	29	24	75	83	9	M8 × 30	3.9	194	8,600	29.8	14.2	795
48 × 80	48	40	29	24	80	88	9	M8 × 30	3.9	207	8,600	27.9	13.3	905
50 × 80	48	40	29	24	80	88	9	M8 × 30	3.9	216	8,600	26.8	13.3	860
55 × 85	48	40	29	24	85	94	10	M8 × 30	3.9	277	10,000	28.4	14.6	935
60 × 90	48	40	29	24	90	99	10	M8 × 30	3.9	302	10,000	26.0	13.8	1,000
65 × 95	48	40	29	24	95	104	12	M8 × 30	3.9	374	11,500	27.5	14.9	1,070
70 × 110	62	52	37	30	110	119	10	M10 × 40	7.5	554	15,800	29.0	14.2	2,060
75 × 115	62	52	37	30	115	124	10	M10 × 40	7.5	594	15,800	27.0	13.5	2,170
80 × 120	62	52	37	30	120	129	10	M10 × 40	7.5	633	15,800	25.4	13.0	2,280
85 × 125	62	52	37	30	125	134	12	M10 × 40	7.5	769	18,000	27.3	14.3	2,400
90 × 130	62	52	37	30	130	139	12	M10 × 40	7.5	814	18,000	25.8	13.7	2,510
95 × 135	62	52	37	30	135	144	14	M10 × 40	7.5	1,074	25,000	30.5	16.5	2,650
100 × 145	74	64	46	39	145	154	15	M10 × 40	7.5	1,130	25,000	20.9	11.8	3,950



## SWLE 200-B Type

### Advantages

- ▶ SWLE200-B applies to high transfer torque and precise positioning.
- ▶ No axial shift while assembling.
- ▶ Required shaft :  $\varnothing 19 \sim \varnothing 100 \text{mm}$

### Usage

- ▶ Pulley, gear, flywheel, cam, lever etc.

### Features

- ▶ Material : JIS S45C, KS SCM440, BS 708H42
- ▶ Hardness : HRC 22~25
- ▶ Surface treatment : Barrel grinding.

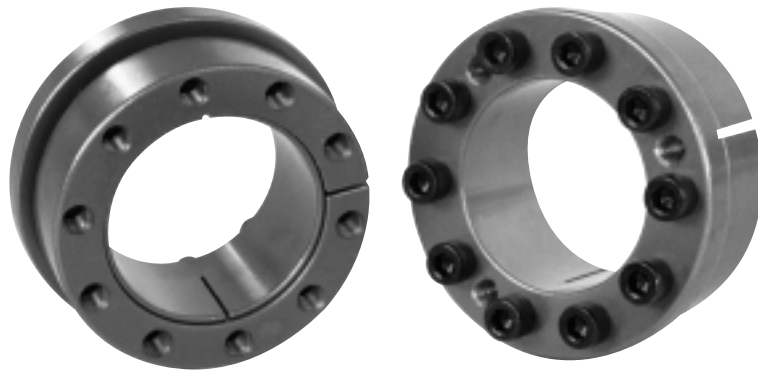

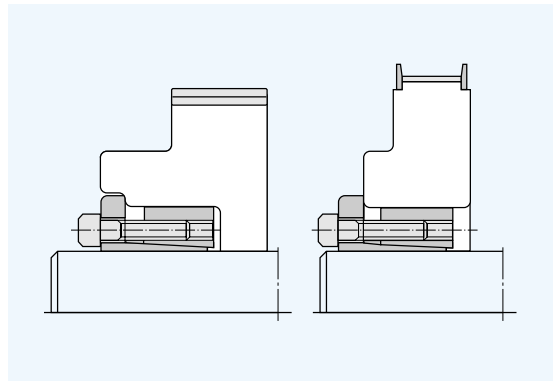
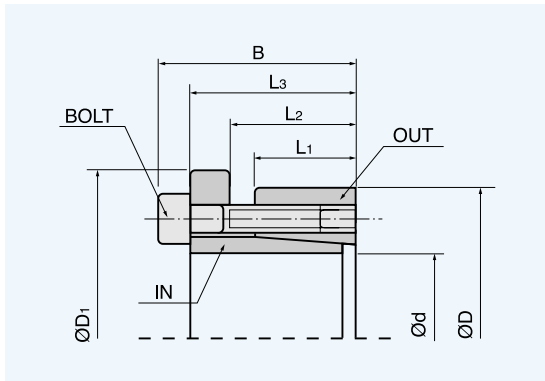

SWLE 100 d x D	Dimensions					Clamp Bolt			Axial Load		Surface Pressure		Weight (g)	
	B	L3	L2	L1	D	D1	Holes	Thread	Torque	Torque Mt (kgf-m)	Axial Load Pax (kgf)	Shaft kgf/mm <sup>2</sup>		Boss kgf/mm <sup>2</sup>
19 × 47	38	32	24	20	47	53	6	M6 × 22	1.6	29	3,000	29.0	9.4	355
20 × 47	38	32	24	20	47	53	6	M6 × 22	1.6	30	3,000	27.5	9.4	350
22 × 47	38	32	24	20	47	53	6	M6 × 22	1.6	33	3,000	25.0	9.4	335
24 × 50	38	32	24	20	50	56	7	M6 × 22	1.6	42	3,450	26.7	10.3	380
25 × 50	38	32	24	20	50	56	7	M6 × 22	1.6	44	3,450	25.7	10.3	370
28 × 55	38	32	24	20	55	62	7	M6 × 22	1.6	48	3,450	22.9	9.4	440
30 × 55	38	32	24	20	55	62	7	M6 × 22	1.6	52	3,450	21.4	9.4	425
32 × 60	38	32	24	20	60	68	9	M6 × 22	1.6	71	4,450	25.8	11.0	510
35 × 60	38	32	24	20	60	68	9	M6 × 22	1.6	78	4,450	23.6	11.0	475
38 × 65	38	32	24	20	65	73	9	M6 × 22	1.6	85	4,450	21.7	10.0	550
40 × 65	38	32	24	20	65	73	9	M6 × 22	1.6	90	4,450	20.6	10.2	520
42 × 75	48	40	29	24	75	83	9	M8 × 30	3.9	173	8,200	30.5	13.5	955
45 × 75	48	40	29	24	75	83	9	M8 × 30	3.9	185	8,200	28.4	13.5	900
48 × 80	48	40	29	24	80	88	9	M8 × 30	3.9	198	8,200	26.7	12.7	1,010
50 × 80	48	40	29	24	80	88	9	M8 × 30	3.9	206	8,200	25.6	12.7	950
55 × 85	48	40	29	24	85	94	10	M8 × 30	3.9	252	9,100	25.8	13.2	1,060
60 × 90	48	40	29	24	90	99	10	M8 × 30	3.9	275	9,100	23.7	12.5	1,130
65 × 95	48	40	29	24	95	104	12	M8 × 30	3.9	357	11,000	26.3	14.2	1,220
70 × 110	62	52	37	30	110	119	10	M10 × 40	7.5	504	14,400	26.4	12.9	2,280
75 × 115	62	52	37	30	115	124	10	M10 × 40	7.5	540	14,400	24.6	12.3	2,400
80 × 120	62	52	37	30	120	129	10	M10 × 40	7.5	575	14,400	23.0	11.8	2,520
85 × 125	62	52	37	30	125	134	12	M10 × 40	7.5	734	17,000	26.0	13.6	2,660
90 × 130	62	52	37	30	130	139	12	M10 × 40	7.5	775	17,000	24.6	13.0	2,780
95 × 135	62	52	37	30	135	144	14	M10 × 40	7.5	955	20,000	27.2	14.7	2,980
100 × 145	74	64	46	39	145	154	15	M10 × 40	7.5	1,080	21,000	19.9	11.3	4,300



## SWLE 200-C Type

### Advantages

- ▶ SWLE200-C can be used in connecting the shaft and boss when it requires a ultra high transfer torque.
- ▶ No axial shift while assembling.
- ▶ Required shaft : 25~200mm

### Usage

- ▶ Large scale pulley
- ▶ Driver of each press



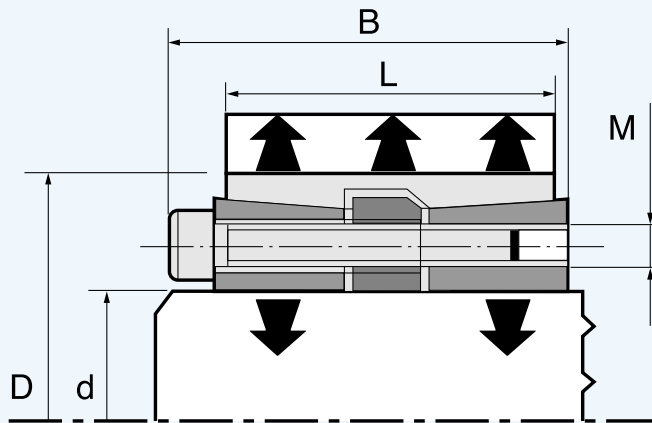

SWLE 200C d x D	Dimensions (mm)			Torque Nm	Axial Thrust KN	Screw s Nm	Surface Torque N/m <sup>2</sup>
	M	L	B				
25 x 50	M6	45	51	900	70	17	90
30 x 55	M6	45	51	1,100	70	17	90
35 x 60	M6	45	51	1,600	90	17	110
40 x 65	M8	45	51	2,400	120	17	110
45 x 75	M8	45	51	3,300	150	41	140
50 x 80	M8	64	72	4,250	160	41	100
60 x 90	M8	64	72	6,100	200	41	120
70 x 110	M10	78	88	10,800	320	83	130
80 x 120	M10	78	88	14,500	360	83	130
90 x 130	M10	78	88	18,100	390	83	130
100 x 145	M12	100	112	26,500	520	145	120
110 x 155	M12	100	112	32,000	580	145	110
120 x 165	M12	100	112	40,000	670	145	120
130 x 180	M14	116	130	51,000	790	230	120
140 x 190	M14	116	130	64,000	920	230	120
150 x 200	M14	116	130	74,000	980	230	130
160 x 210	M14	116	130	84,000	1,050	230	130
170 x 225	M16	146	162	109,000	1,280	355	120
180 x 235	M16	146	162	123,000	1,370	355	120
190 x 250	M16	146	162	139,000	1,460	355	120
200 x 260	M16	146	162	146,000	1,460	355	110



## SWLE 200-D

### Characteristics

- ▶ Medium–high torque
- ▶ No shaft–hub axial movement
- ▶ Limited installation time
- ▶ Quick dismantling

### Features

- ▶ Material: DIN C45, JIS S45C, KS SM45C2
- ▶ Hardness: HRC 22~25
- ▶ Surface treatment: Barrel grinding.

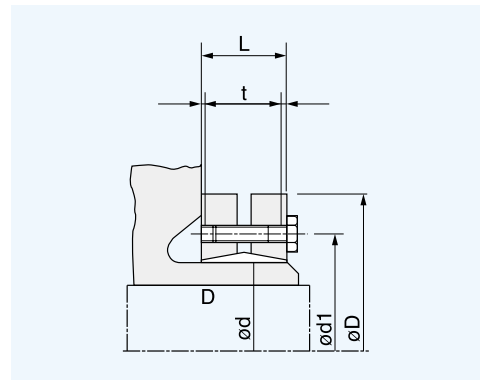
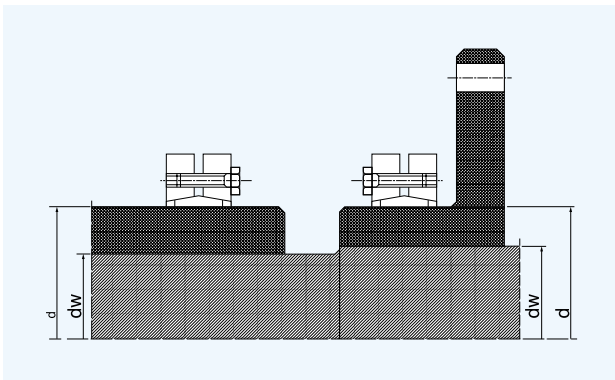

SWLE200D	Dimensions					shaft diameter dw	Torque Mt	Axial Thrust Fass.	Tightening screws DIN 931-10.9	Tightening torque Ms	Contact pressure Pw
	d	D	I	L	d1						
mm	mm	mm	mm	mm	mm	mm	Nm	KN	No. x type	Nm	N/mm2
14	38	7	11.0	23	2.00	11 12	30 50	6 9	4 × M 5	4	186
16	41	11	15.0	26	2.00	13 14	70 90	10 13	5 × M 5	4	130
24	50	14	19.5	36	2.75	19 20 21	170 210 250	25 27 29	6 × M 5	4	286
30	60	16	21.5	44	2.75	24 25 26	300 340 380	29 31 33	7 × M 5	4	233
36	72	18	23.5	52	2.75	28 30 31	440 570 630	50 58 58	5 × M 6	12	307
44	80	20	25.5	61	2.75	32 33 34	620 780 860	64 74 77	7 × M 6	12	317
50	90	22	27.5	70	2.75	36 40 42	940 1160 1380	79 86 92	8 × M 6	12	289
55	100	23	30.5	75	3.75	42 45 48	1380 1520 1680	79 88 97	8 × M 6	12	252
62	110	23	30.5	86	3.75	48 50 52	1840 2200 2400	100 111 117	10 × M 6	12	279
68	115	23	30.5	86	3.75	50 55 60	2000 2500 3150	97 106 120	10 × M 6	12	255
75	138	25	32.5	100	3.75	55 60 65	2500 3200 3950	119 137 155	7 × M 8	30	273
80	145	25	32.5	100	3.75	60 65 70	3200 3900 4600	124 140 158	7 × M 8	30	256
85	155	30	39	114	4.50	65 70 75	4900 6100 7400	175 195 216	10 × M 8	30	285
90	155	30	39.0	114	4.50	65 70 75	4750 6000 7250	170 190 210	10 × M 8	30	271
100	170	34	44.0	124	5.00	70 75 80	6900 7500 9000	195 220 240	12 × M 8	30	258
110	185	39	50.0	136	5.50	75 80 85	7200 9000 10800	229 252 262	9 × M 10	59	244
115	188	39	50.0	141	5.50	80 85 90	7400 9200 11100	235 259 269	9 × M 10	59	234
120	215	42	54.0	160	6.00	90 95 100	10900 13300 14500	285 314 340	12 × M 10	59	277
125	215	42	54.0	160	6.00	90 95 100	11000 13000 15000	296 324 352	12 × M 10	59	266
130	215	42	54.0	160	6.00	90 95 100	11300 13300 15400	304 333 362	12 × M 10	59	255
140	230	46	60.5	175	7.25	100 105	15100 17600 20100	367 396 425	10 × M 12	100	264
155	265	50	64.5	192	7.25	105 110	22000 25000 28000	447 478 509	12 × M 12	100	263
160	265	50	64.5	192	7.25	110 115 120	22600 25700 28800	460 490 520	12 × M 12	100	254
165	290	56	71	210	7.50	115 120 125	31000 35000 39000	595 630 655	8 × M 16	250	277
170	290	56	71	210	7.5	120 125 130	31900 36000 40100	610 640 670	8 × M 16	250	268
175	300	56	71	220	7.5	125 130 135	36000 41000 45000	605 639 675	8 × M 16	250	261
180	300	56	71	220	7.5	130 135 140	37000 42200 46300	600 640 685	8 × M 16	250	253
185	330	71	86	236	7.5	135 140 145	52000 57000 62000	778 819 861	10 × M 16	250	244
190	330	71	86	236	7.5	140 145 150	53500 59700 63800	800 840 885	10 × M 16	250	237
195	350	71	86	246	7.5	140 150 155	65000 76000 81500	933 1025 1071	12 × M 16	250	277
200	350	71	86	246	7.5	150 155 160	74000 80000 86000	990 1035 1080	12 × M 16	250	270
220	370	88	104	270	8.0	160 165 170	95000 102000 110000	1190 1239 1290	15 × M 16	250	248
240	405	92	109	295	8.5	170 180 190	120000 136000 156000	1464 1576 1675	12 × M 20	490	272



## SWLE 300 Type

### Advantages

- ▶ SWLE300 can be used when it requires large-scale KEY and radial work is not allowed.
- ▶ Max assembled up to 4, suitable for carrying high loads.
- ▶ Required shaft :  $\varnothing 10 \sim \varnothing 200 \text{mm}$

### Usage

- ▶ pulley, gear, flywheel, cam, lever etc.

### Features

- ▶ Material : JIS SCM440
- ▶ Hardness : HRC 22~25
- ▶ Surface treatment: Barrel grinding.





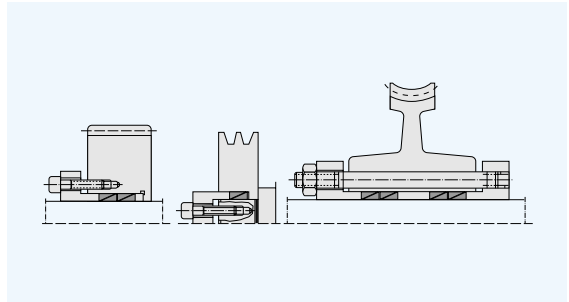
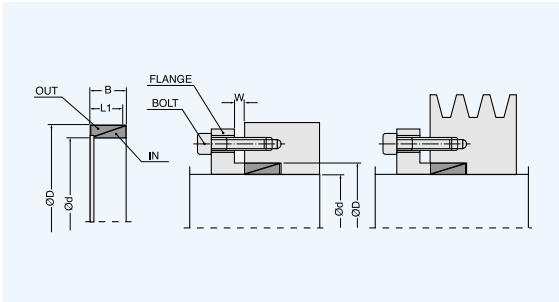

SWLE 100 d x D	Dimensions		LOCKING ELEMENT				Axial Load		Surface Pressure		Weight (g)
	B	L1	1W	2W	3W	4W	Torque kgf-m	Axial Thrust kgf	SHAFT kgf/mm <sup>2</sup>	BOSS kgf/mm <sup>2</sup>	
10 × 13	4.5	3.7	2.5	2.5	3	4	0.69	135	12	9.3	1.6
11 × 14	4.5	3.7	2.5	2.5	3	4	0.84	150	12	9.4	1.8
12 × 15	4.5	3.7	2.5	2.5	3	4	1	165	12	9.6	2.0
13 × 16	4.5	3.7	2.5	2.5	3	4	1.1	180	12	9.8	2.4
14 × 18	6.3	5.3	3	4	5	6	2	285	12	9.4	4.6
15 × 19	6.3	5.3	3	4	5	6	2.3	300	12	9.5	5.0
16 × 20	6.3	5.3	3	4	5	6	2.6	325	12	9.6	5.0
17 × 21	6.3	5.3	3	4	5	6	2.9	345	12	9.8	5.4
18 × 22	6.3	5.3	3	4	5	6	3.3	365	12	9.8	5.6
19 × 24	6.3	5.3	3	4	5	6	3.6	385	12	9.5	7.2
20 × 25	6.3	5.3	3	4	5	6	4	400	12	9.6	7.8
22 × 26	6.3	5.3	4	4	5	6	4.9	445	12	10.2	6.8
24 × 28	6.3	5.3	4	4	5	6	5.8	485	12	10.3	7.4
25 × 30	6.3	5.3	4	4	5	6	6.3	500	12	10	9.8
28 × 32	6.3	5.3	4	4	5	6	8	570	12	10.5	8.6
30 × 35	6.3	5.3	4	4	5	6	9.1	610	12	10.3	11.4
32 × 36	6.3	5.3	4	4	5	6	10.4	650	12	10.7	9.8
35 × 40	7	6	4	4	5	6	14.2	810	12	10.5	15.0
36 × 42	7	6	4	4	5	6	15	830	12	10.3	18.2
38 × 44	7	6	4	4	5	6	16.7	880	12	10.4	18.8
40 × 45	8	6.6	4	5	6	7	19.8	990	12	10.7	20.0
42 × 48	8	6.6	4	5	6	7	21.9	1,040	12	10.5	23.8
45 × 52	10	8.6	4	5	6	7	33.3	1,480	12	10.4	38.4
48 × 55	10	8.6	4	5	6	7	38	1,580	12	10.5	41.8
50 × 57	10	8.6	4	5	6	7	41.2	1,650	12	10.5	42.2
55 × 62	10	8.6	4	5	6	7	49.9	1,800	12	10.7	46.8
56 × 64	12	10.4	4	5	6	7	63.2	2,250	12	10.5	66.8
60 × 68	12	10.4	4	5	6	7	72.5	2,400	12	10.6	73
63 × 71	12	10.4	4	5	6	7	80	2,500	12	10.7	75
65 × 73	12	10.4	4	5	6	7	85	2,600	12	10.7	76
70 × 79	14	12.2	4	6	7	8	114	3,200	12	10.6	102
71 × 80	14	12.2	4	6	7	8	118	3,300	12	10.7	104
75 × 84	14	12.2	4	6	7	8	131	3,500	12	10.7	110
80 × 91	17	15	4	6	7	8	186	4,650	12	10.6	175
85 × 96	17	15	4	6	7	8	210	4,900	12	10.6	190
90 × 101	17	15	4	6	7	8	235	5,200	12	10.7	200
95 × 106	17	15	4	6	7	8	262	5,500	12	10.8	210
100 × 114	21	18.7	5	6	7	9	362	7,200	12	10.5	360
110 × 124	21	18.7	5	6	7	9	438	7,900	12	10.7	380
120 × 134	21	18.7	5	6	7	9	521	8,700	12	10.8	420
130 × 148	28	25.3	5	7	9	11	839	12,900	12	10.5	800
140 × 158	28	25.3	6	7	9	11	973	13,900	12	10.6	860
150 × 168	28	25.3	6	7	9	11	1,115	14,900	12	10.7	920
160 × 178	28	25.3	6	7	9	11	1,270	15,900	12	10.8	960
170 × 191	33	30	7	8	9	12	1,710	20,100	12	10.7	1,450
180 × 201	33	30	7	9	10	12	1,920	21,300	12	10.8	1,500
190 × 211	33	30	7	9	10	12	2,130	22,500	12	10.8	1,600
200 × 224	38	34.8	7	9	11	13	2,740	27,400	12	10.7	2,200



## POWER COUPLING

**Power Coupling is used to increase the accuracy of tightening between two shafts in machining the fixed surface of ball screw and the assembly of servo-motor.**

### Features

1. Possibility in using it in the state that the moment of inertia is low with a small-sized lightweight and the rotation is high-speed.
2. No backlash and convenience of maintenance after mounting.
3. The strength of ball screw is improved. No effect of rope skipping.
4. No key because it tightens with friction only concluding the lock bolt.
5. It goes on keeping the accurate balancing during the high-speed rotation.

### Applications

- ▶ CNC Lathe, Milling M/C, Machining Center, Tapping M/C, Various Special Purpose Machine Tools Shaft and Shaft Coupling, The Equipment Connecting the Shaft and That of Motor.

### Diameter

- ▶  $\varnothing 16\text{mm} \sim \varnothing 48\text{mm}$

### Material

- ▶ DIN C45, JIS S45C, KS SM45C

### Hardness

- ▶ HRC 22~25

## PRINCIPLE & STRUCTURE

Pulling side ring by lock bolt, and taper inside side ring, suppressing body taper, it tightening with friction by the principle of a wedge locking the shaft strongly. Body taper has got couple of slits, makes it easy to be mounted and improves the tightening efficiency.

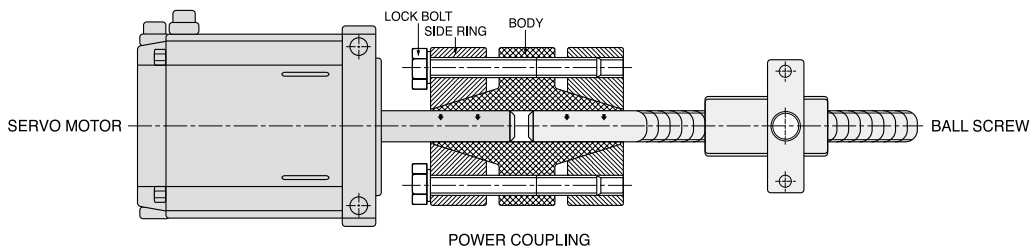

A same shaft of the caliber

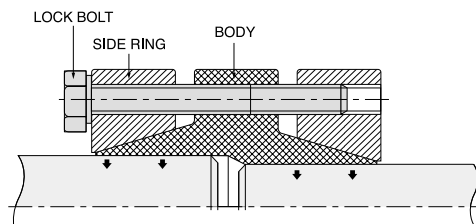

A different shaft of the caliber



Flexible Coupling



Power Coupling



## POWER COUPLING (P Type)

Standard



Special

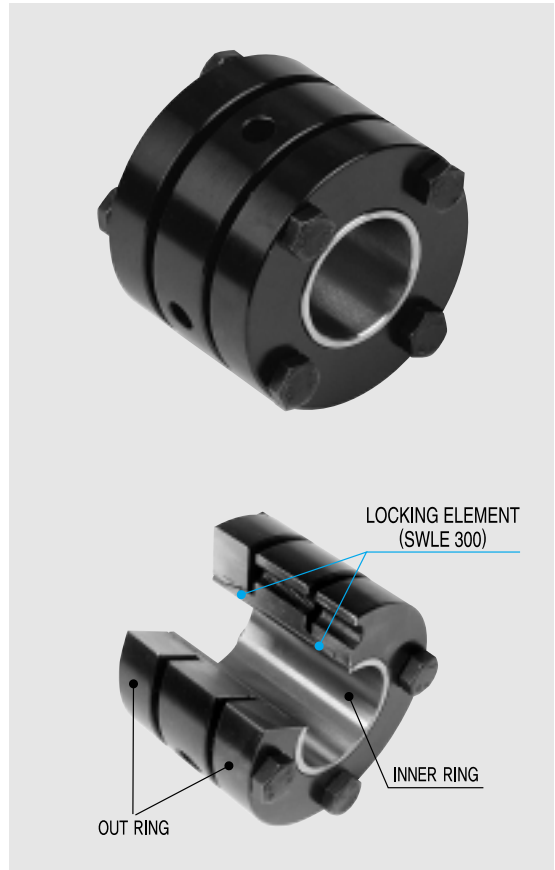

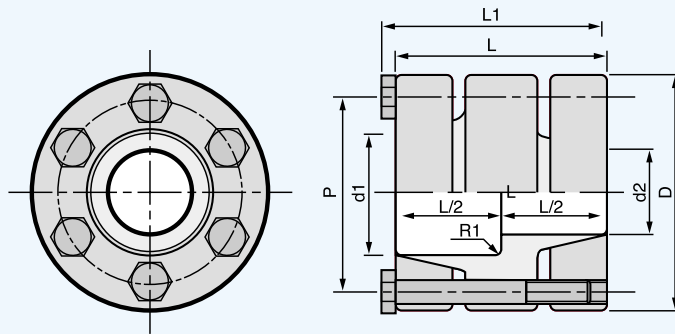

PART No.	d1	d2	D	L	L1	P.C.D P	Locking Bolts SIZE X L X HOLES	Torque Capacity (Maximum Torque)		Axial Force Capacity (Maximum Thrust)		Max Rotational Frequency (Maximum) r.p.m	Bolt Wrench Tightening Torque	
								Nm	kgf-m	N x 10 <sup>2</sup>	kgf		Nm	kgf-m
P-53-16-16	16	16	53	56	61.0	41.0	M6 x 50 x 6	78.5	8.0	9.81	1000	14500	17.7	1.8
P-53-20-16	20	16	53	56	61.0	41.0	M6 x 50 x 6	78.5	8.0	9.81	1000	14500	17.7	1.8
P-53-20-20	20	20	53	56	61.0	41.0	M6 x 50 x 6	98.1	10.0	9.81	1000	14500	17.7	1.8
P-53-22-20	22	20	53	56	61.0	41.0	M6 x 50 x 6	98.1	10.0	9.81	1000	14500	17.7	1.8
P-53-22-22	22	22	53	56	61.0	41.0	M6 x 50 x 6	118.0	12.0	9.81	1000	14500	17.7	1.8
P-58-25-20	25	20	58	58	63.0	45.0	M6 x 50 x 6	98.1	10.0	9.81	1000	12500	17.7	1.8
P-58-25-22	25	22	58	58	63.0	45.0	M6 x 50 x 6	118.0	12.0	9.81	1000	12500	17.7	1.8
P-58-25-25	25	25	58	58	63.0	45.0	M6 x 50 x 6	127.1	13.0	9.81	1000	12500	17.7	1.8
P-63-30-25	30	25	63	60	65.0	50.5	M6 x 50 x 6	157.0	16.0	11.8	1200	12000	17.7	1.8
P-63-30-30	30	30	63	60	65.0	50.5	M6 x 50 x 6	186.0	19.0	11.8	1200	12000	17.7	1.8
P-68-35-25	35	25	68	60	65.0	56.0	M6 x 50 x 6	157.0	16.0	11.8	1200	10000	17.7	1.8
P-68-35-28	35	28	68	60	65.0	56.0	M6 x 50 x 6	177.0	18.0	11.8	1200	10000	17.7	1.8
P-68-35-30	35	30	68	60	65.0	56.0	M6 x 50 x 6	186.0	19.0	11.8	1200	10000	17.7	1.8
P-68-35-32	35	32	68	60	65.0	56.0	M6 x 50 x 6	206.0	21.0	11.8	1200	10000	17.7	1.8
P-68-35-35	35	35	68	60	65.0	56.0	M6 x 50 x 6	226.0	23.0	11.8	1200	10000	17.7	1.8
P-73-35-42	35	42	73	70	75.0	60.0	M6 x 50 x 6	226.0	23.0	12.7	1300	9000	17.7	1.8
P-73-38-38	38	38	73	70	75.0	60.0	M6 x 50 x 6	245.0	25.0	12.7	1300	9000	17.7	1.8
P-73-42-42	42	42	73	70	75.0	60.0	M6 x 50 x 6	275.0	28.0	12.7	1300	9000	17.7	1.8
P-78-48-48	48	48	78	70	75.0	66.0	M6 x 50 x 6	461.0	47.0	18.6	1900	8000	17.7	1.8

