

# SHAFT SUPPORTER

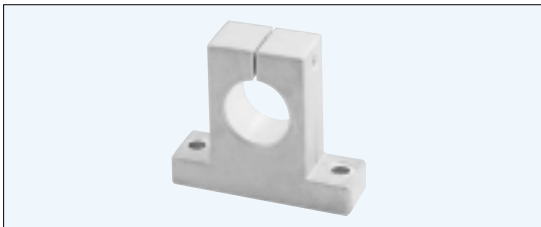

## SHAFT SUPPORTER

### TSK TYPE (Shaft Supporter)



### ● Ordering Example

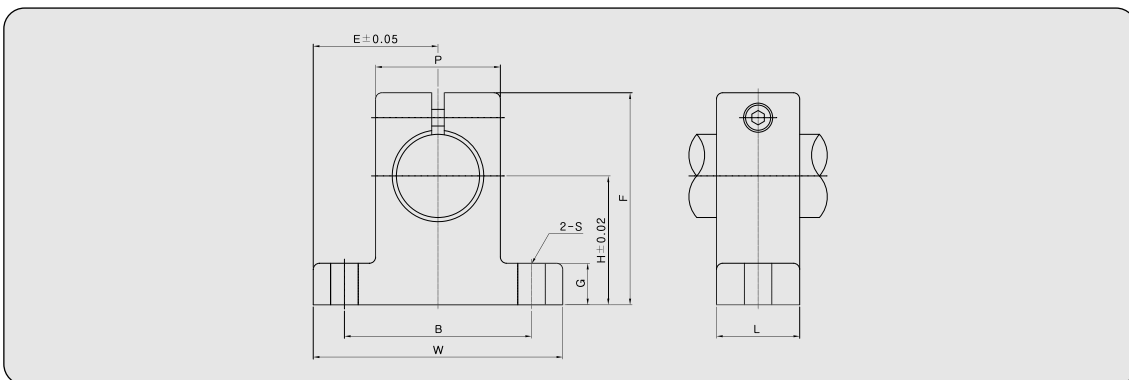
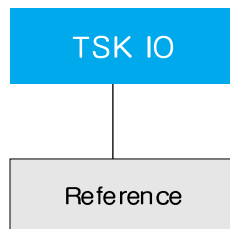

Reference	Major Dimension(mm)									adjusting bolt size	S(bolt size)
	H	E	W	L	F	G	P	B	S		
TSK10	20	21	42	14	32.8	6	18	32	5.5	M4	M5
TSK12	23	21	42	14	37.5	6	20	32	5.5	M4	M5
TSK13	23	21	42	14	37.5	6	20	32	5.5	M4	M5
TSK16	27	24	48	16	44	8	25	38	5.5	M4	M5
TSK20	31	30	60	20	51	10	30	45	6.6	M5	M6
TSK25	35	35	70	24	60	12	38	56	6.6	M6	M6
TSK30	42	42	84	28	70	12	44	64	9	M6	M8
TSK35	50	49	98	32	82	15	50	74	11	M8	M10
TSK40	60	57	114	36	96	15	60	90	11	M8	M10
TSK50	70	63	126	40	120	18	74	100	14	M12	M12

