

**KEYPAD**

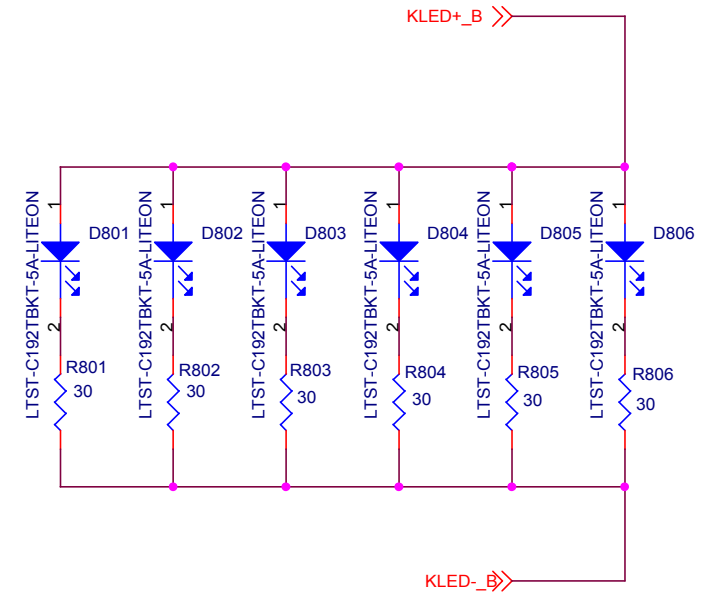

Keyboard Connector On KEYboard

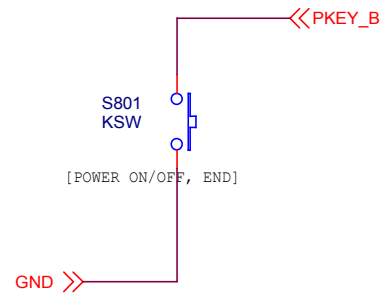
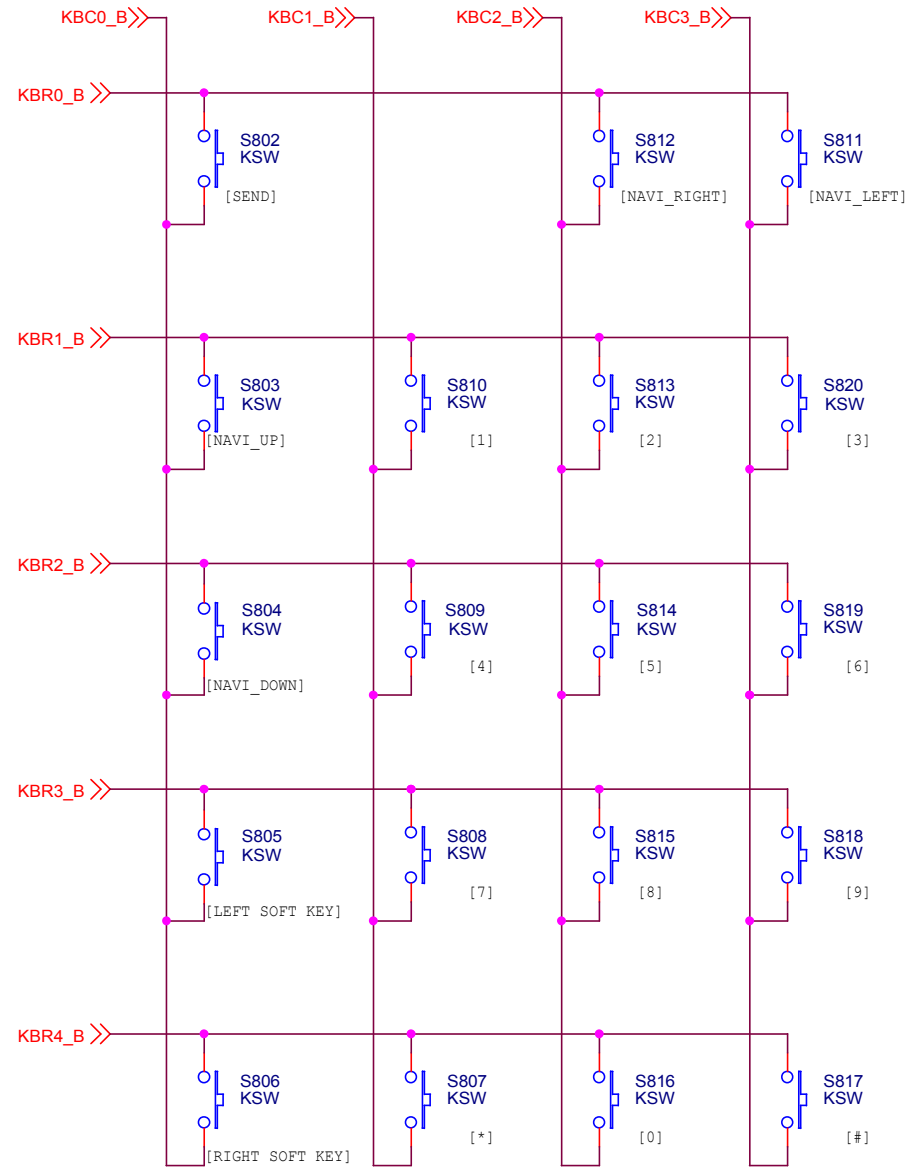
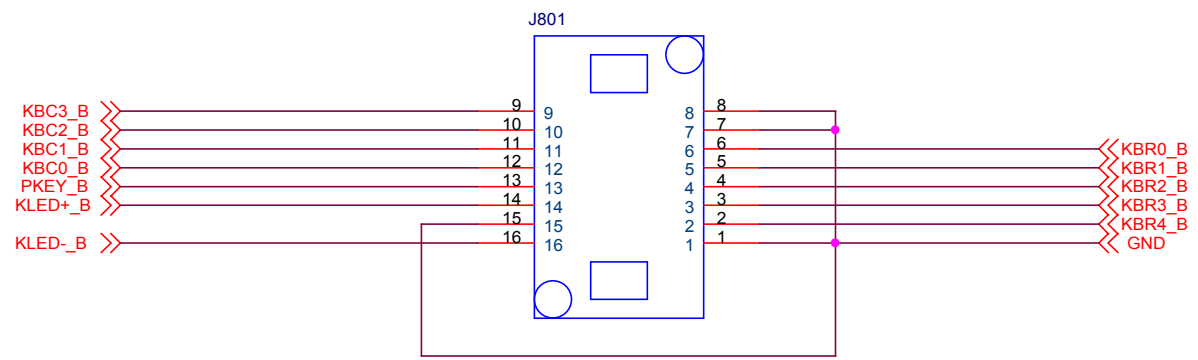

Title			<b>KONKA C736</b>		
Size	Document Number			Rev	
A3	<b>KEYPAD BOARD</b>				
Date:	Wednesday, June 06, 2007		Sheet	1	of 1

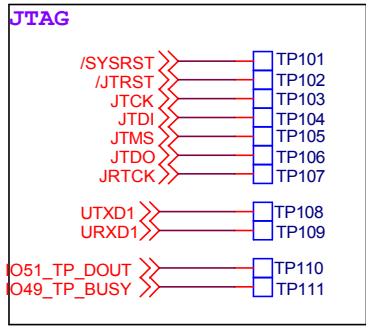
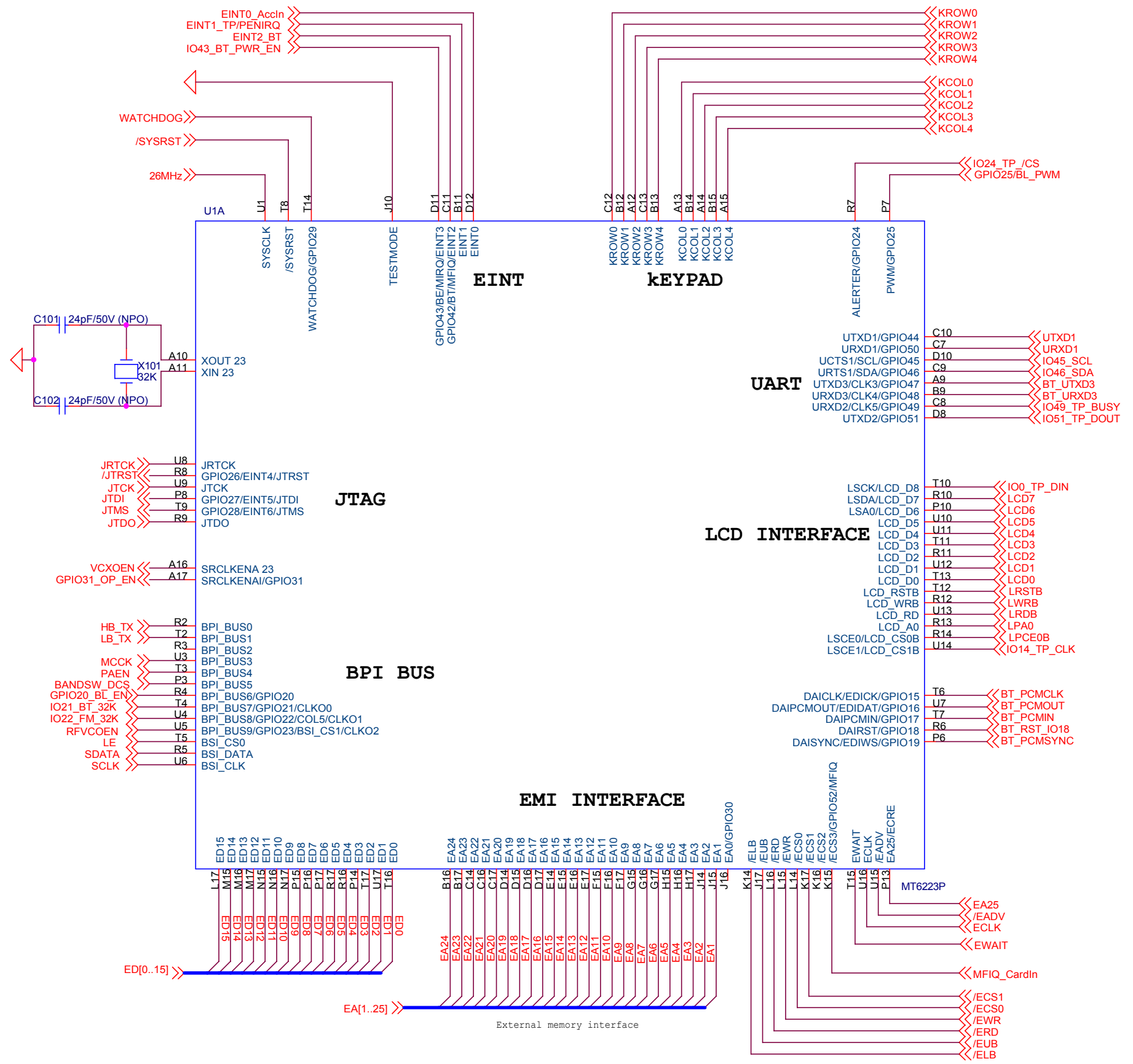

Title		
<b>1. MT6223(P) Digital</b>		
Size	Document Number	Rev
A3	<Doc>	1
Date:	Sunday, August 26, 2007	Sheet 1 of 8

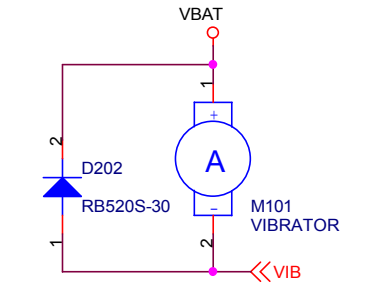
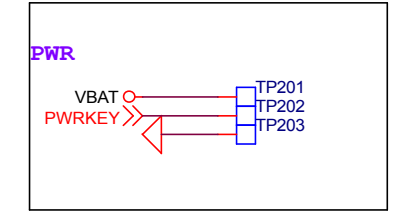
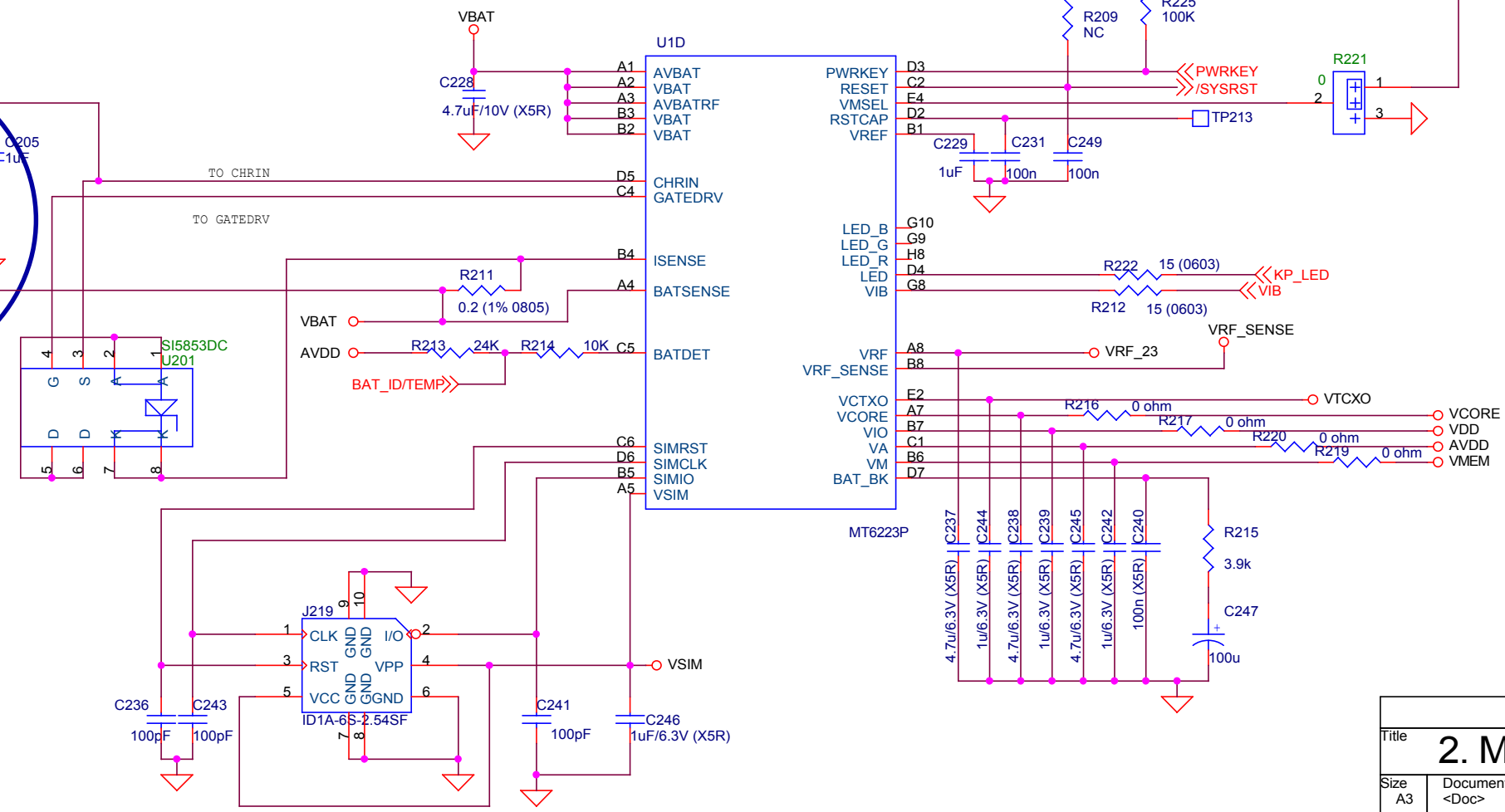
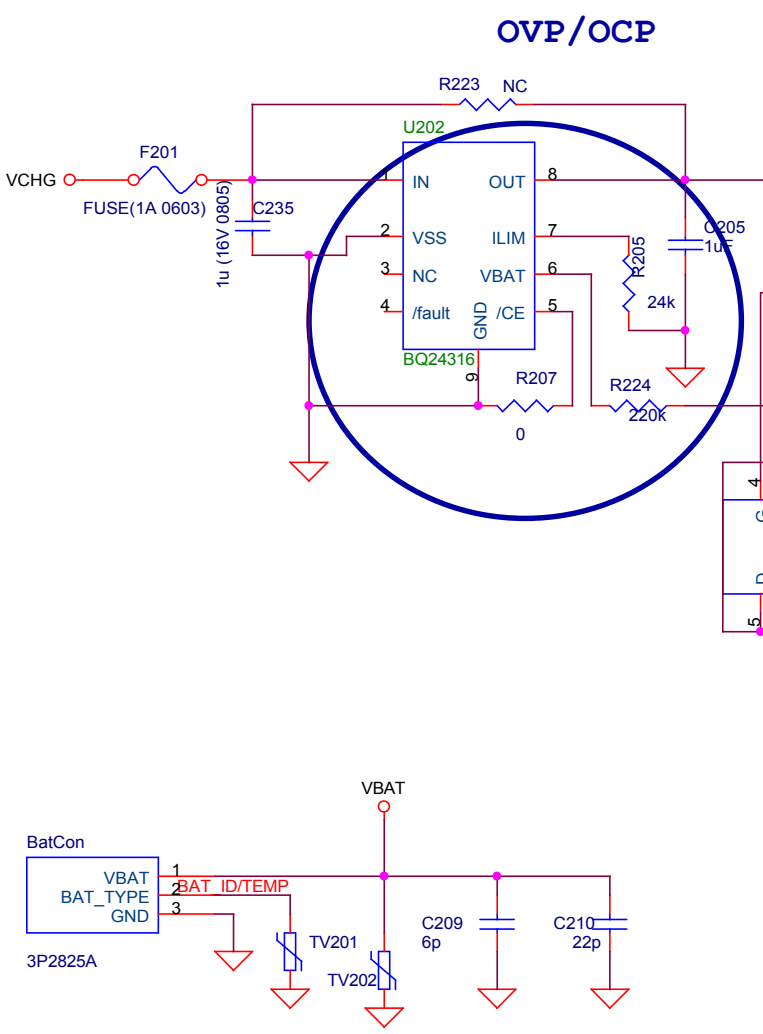
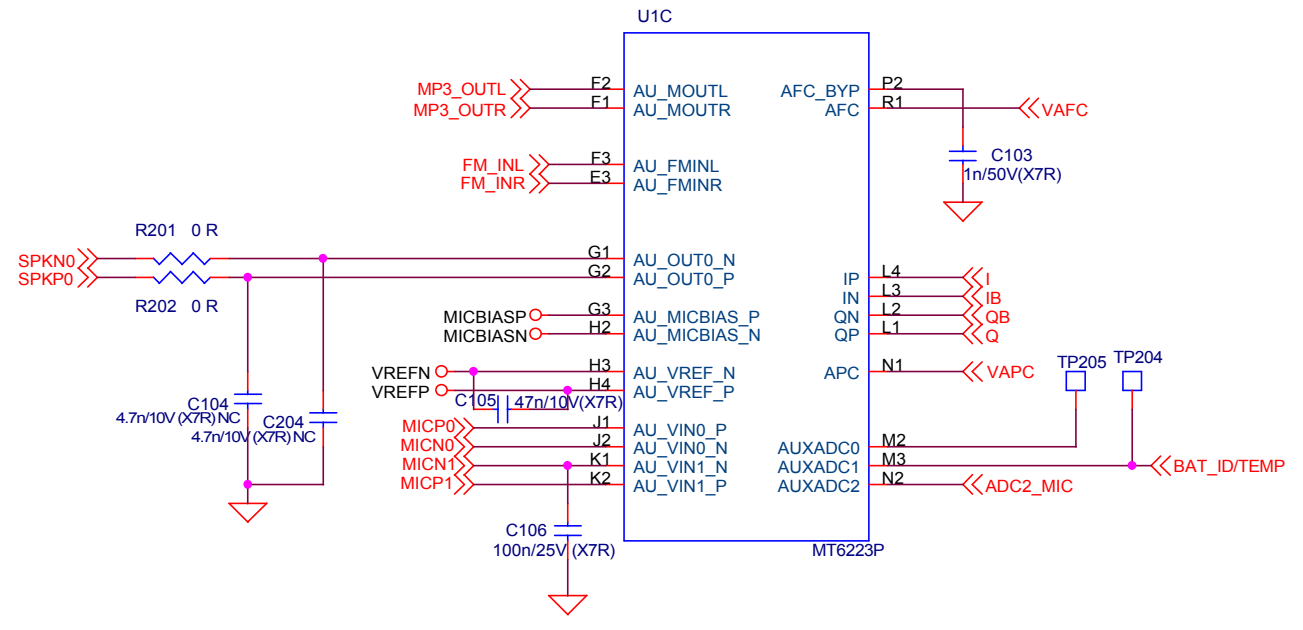
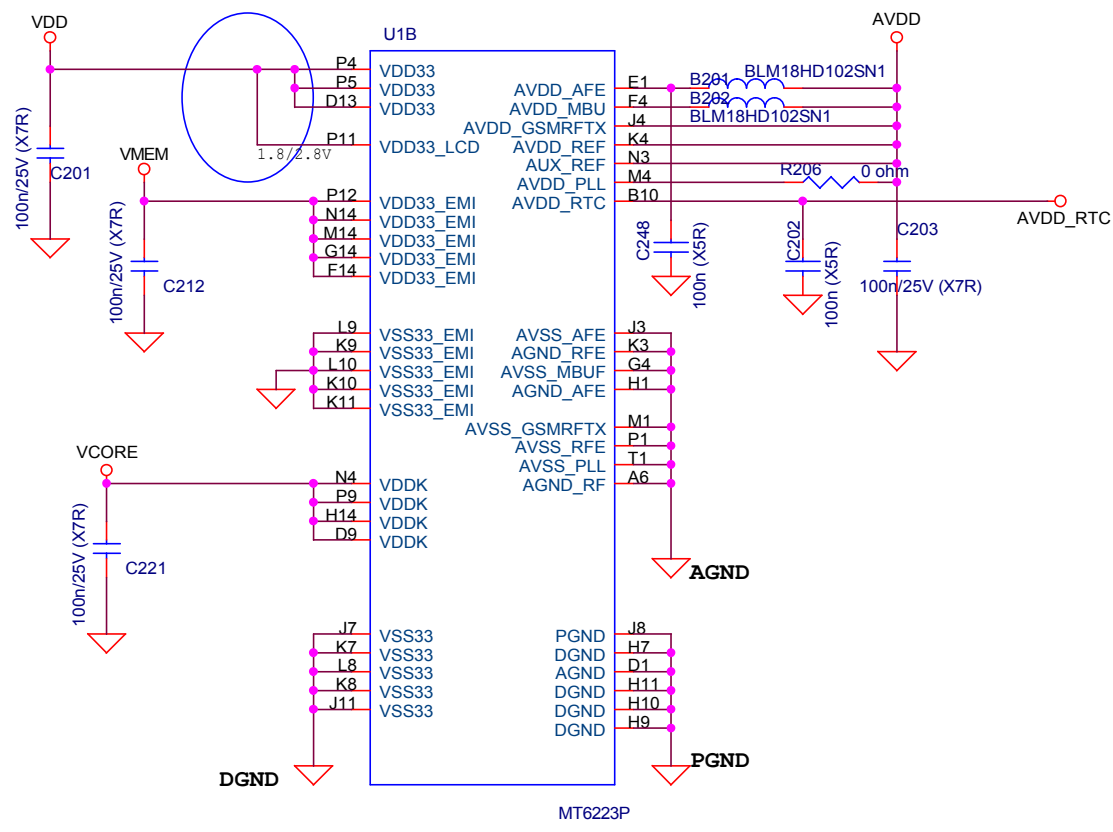

Title		<b>2. MT6223 POWER</b>	
Size	Document Number	Rev	
A3	<Doc>	1	
Date:	Sunday, August 26, 2007	Sheet	2 of 8

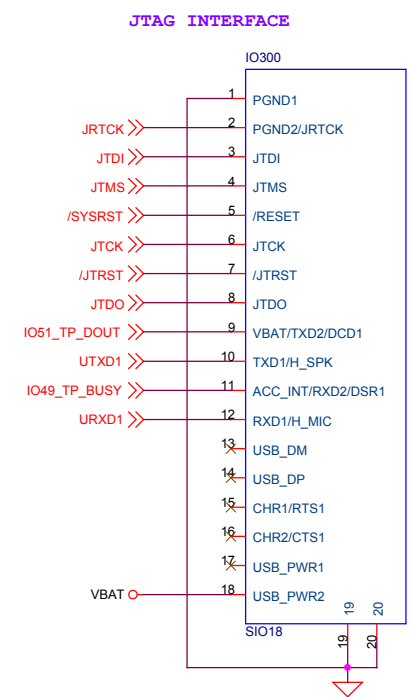
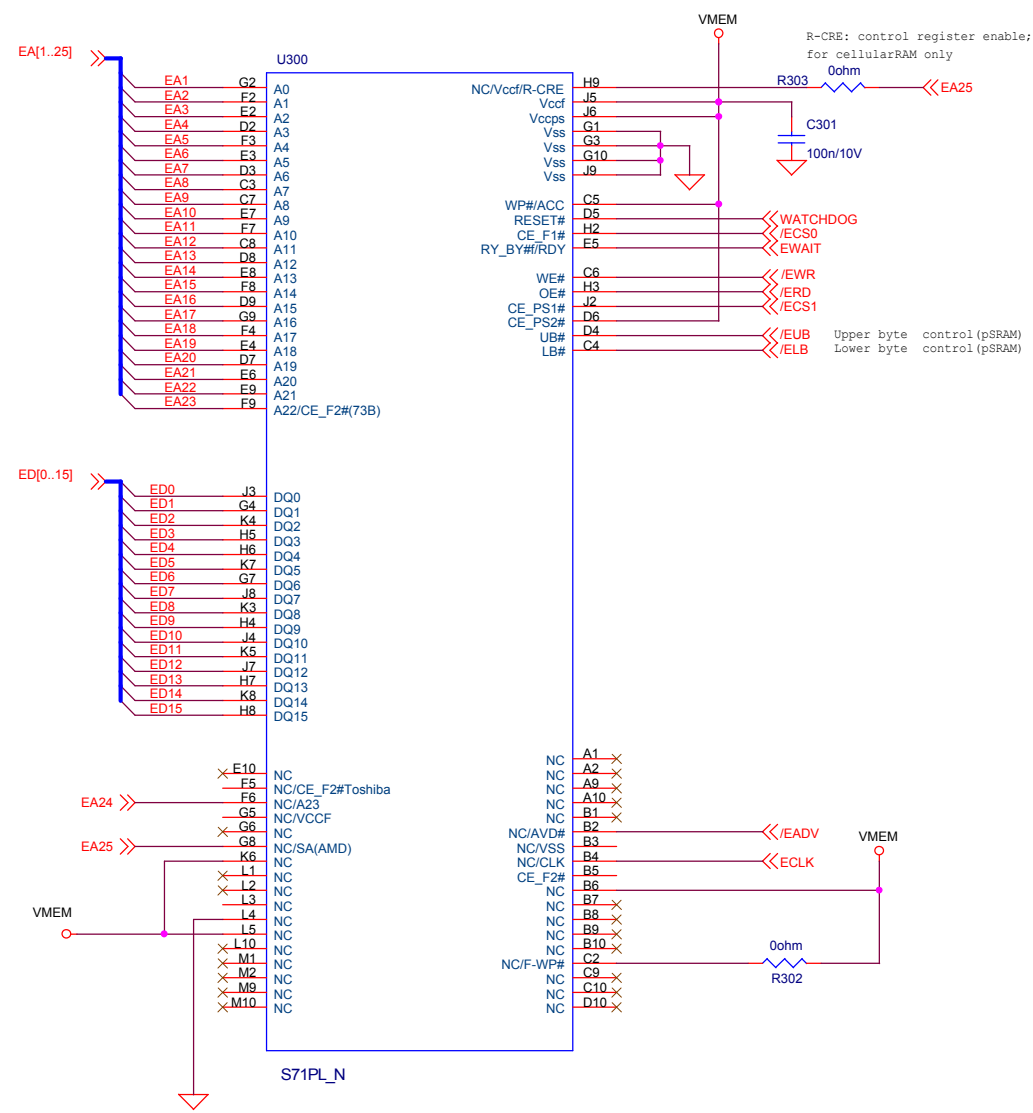

### Spanstion-like MCP

Title		<b>3. MCP</b>	
Size	Document Number	Rev	
C	<Doc>	<Rev Code>	
Date:	Sunday, August 26, 2007	Sheet	3 of 8

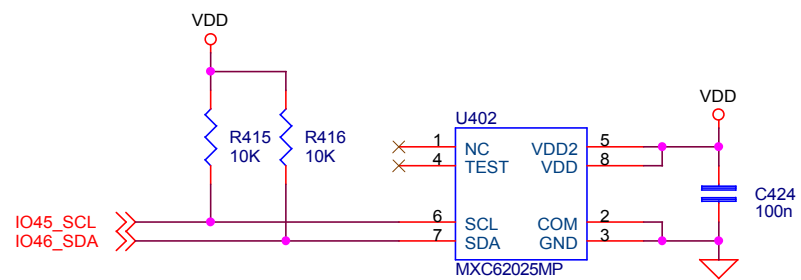
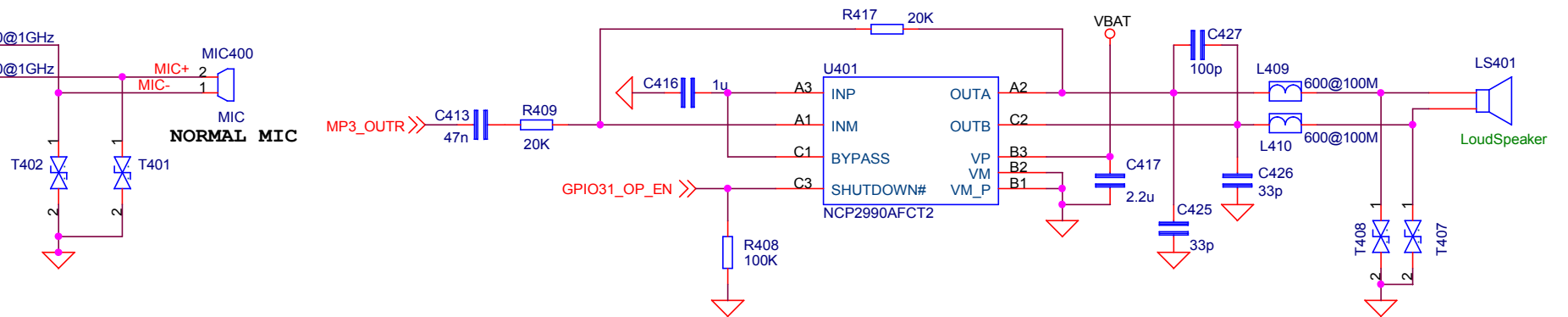
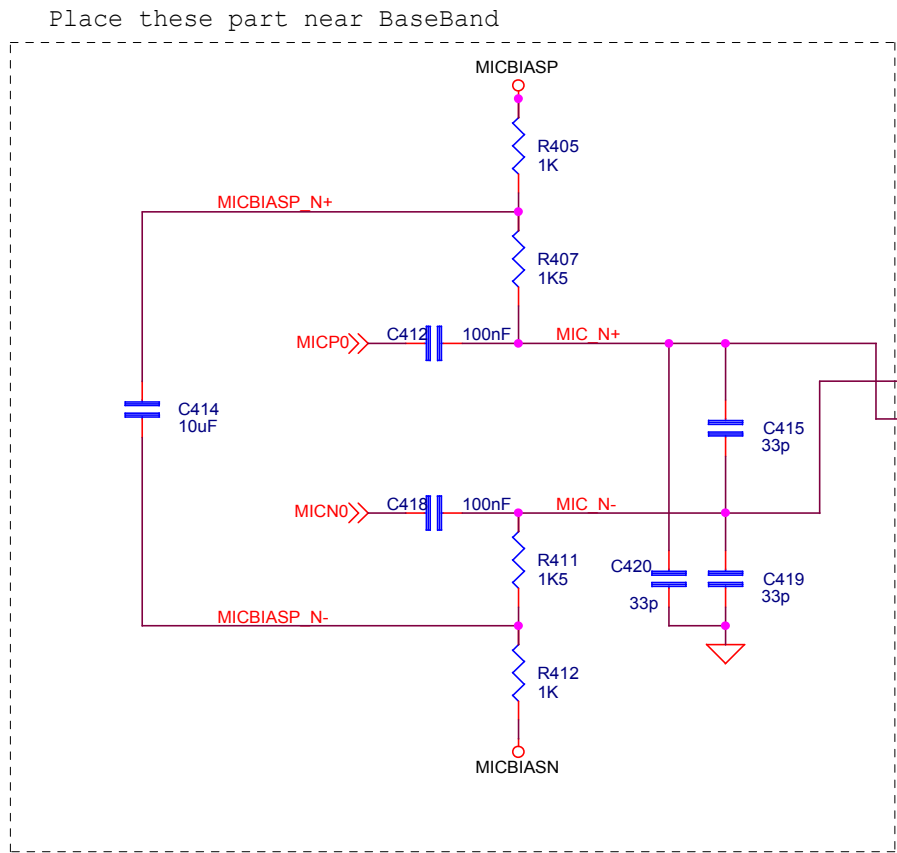
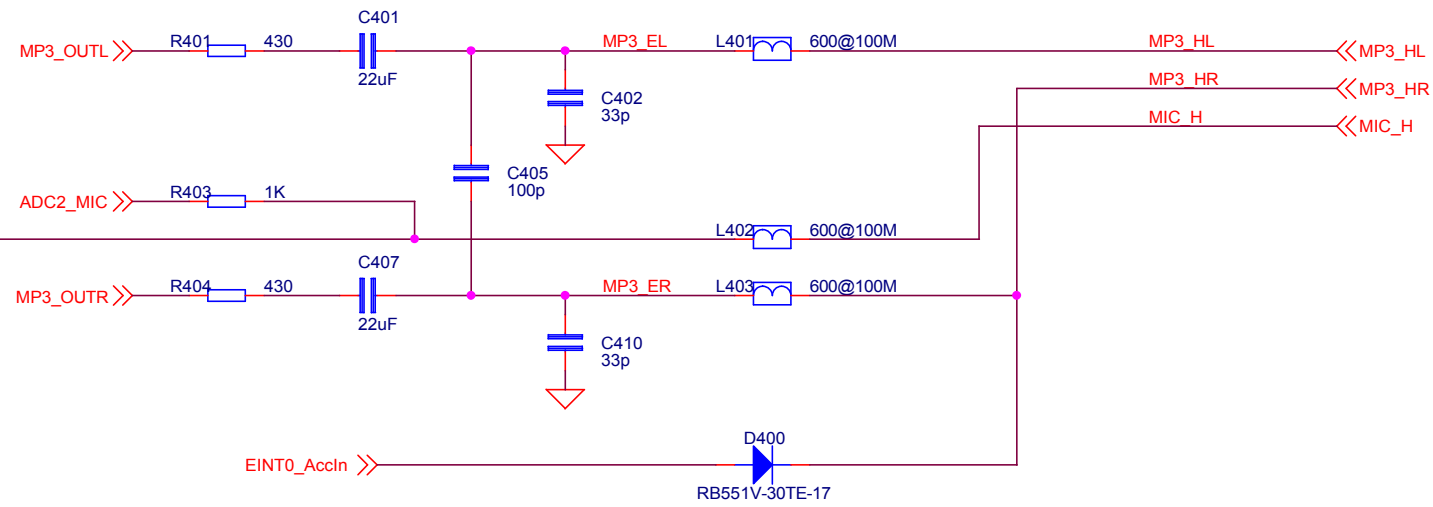
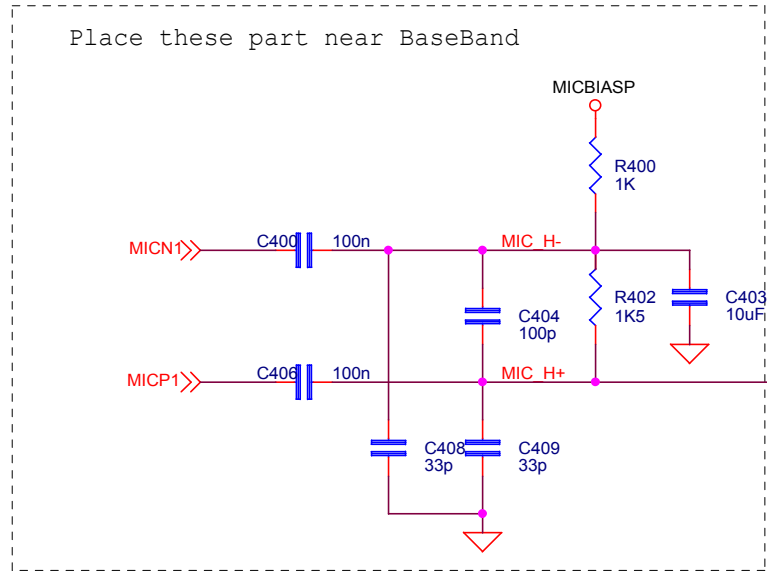

**MEMSIC Circuit**

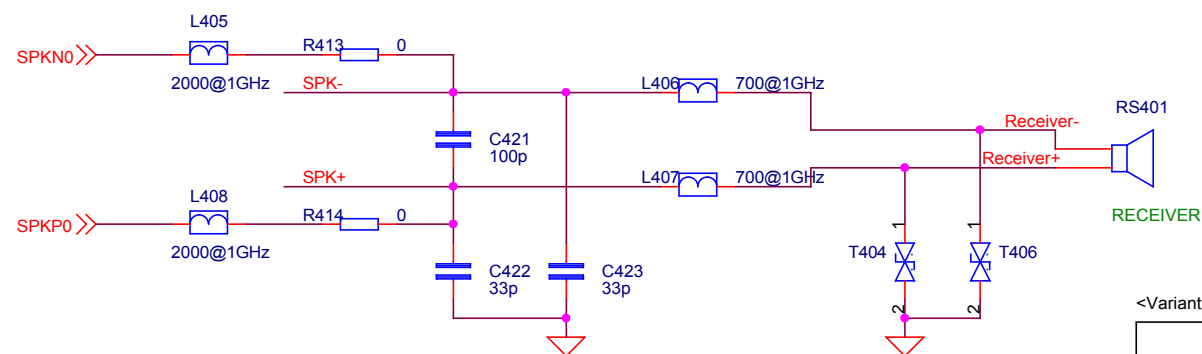

<Variant Name>

Title		<b>MT6223(P)</b>
Size	Document Number	Rev
A3	<b>Audio, Class D dual Amp</b>	1.0
Date:	Sunday, August 26, 2007	Sheet 4 of 8

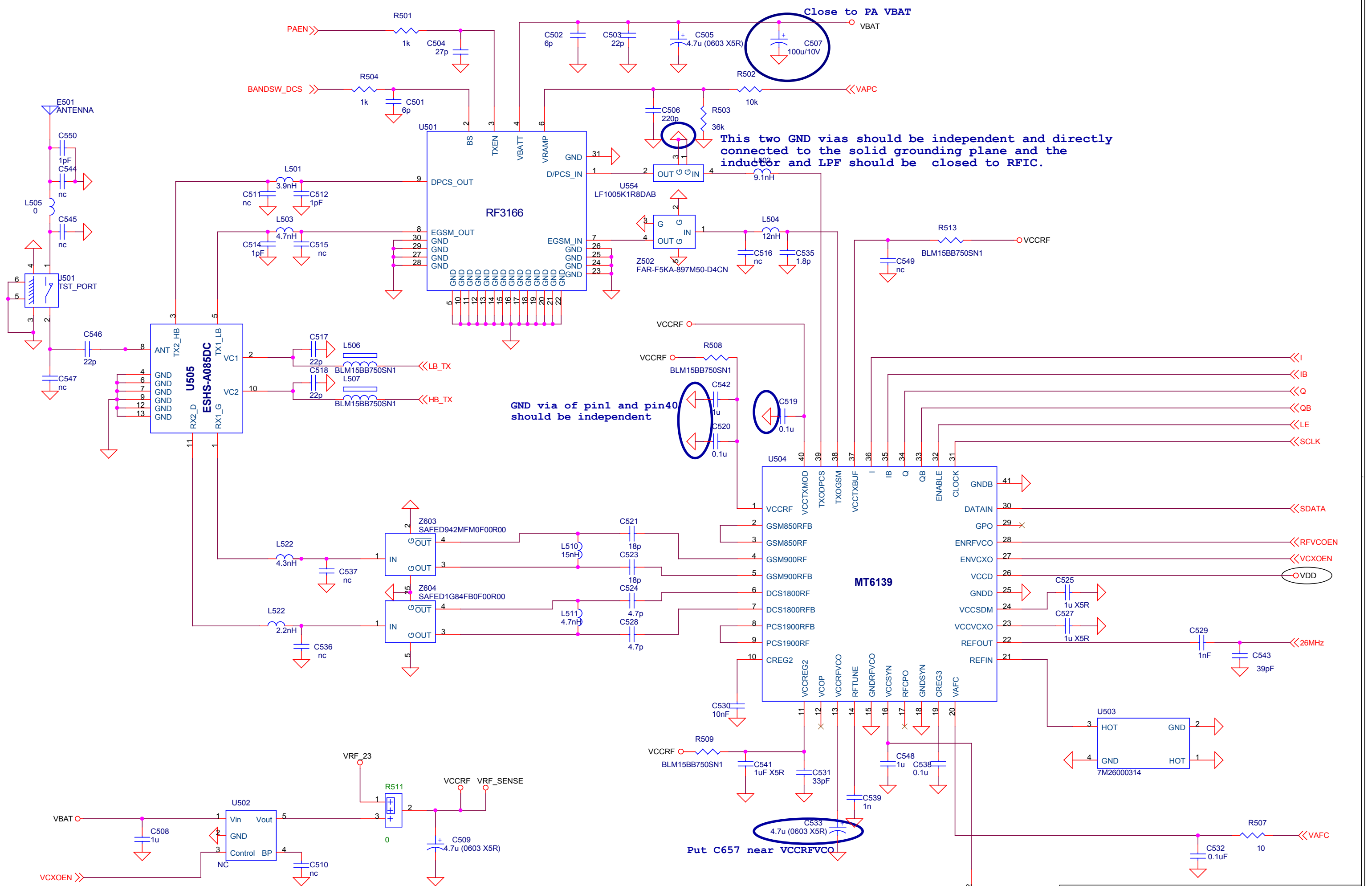

Title		
<b>MT6139_EVB_V1</b>		
Size	Document Number	Rev
A3	<b>MT6139_EVB_V1</b>	1.00
Date:	Sunday, August 26, 2007	Sheet 5 of 8

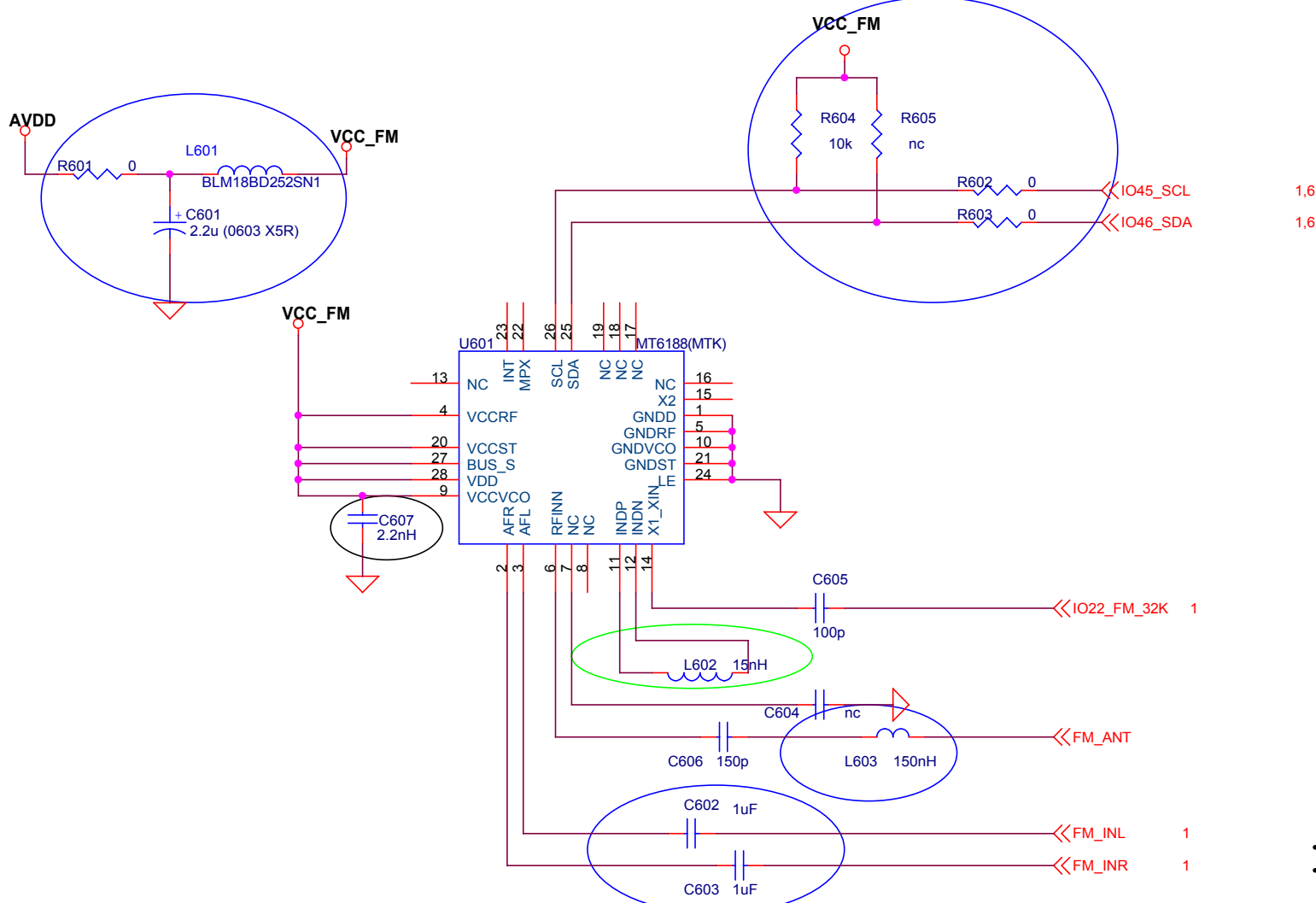

## FM Radio

Note  
For better FM audio BW, C602 & C603 could change to 4.7uF

## KONKA 10pin I/O Interface

Note  
1. Headset use 10 pin I/O interface.  
2. Pin 5 for FM antenna, it use a dedicated line.

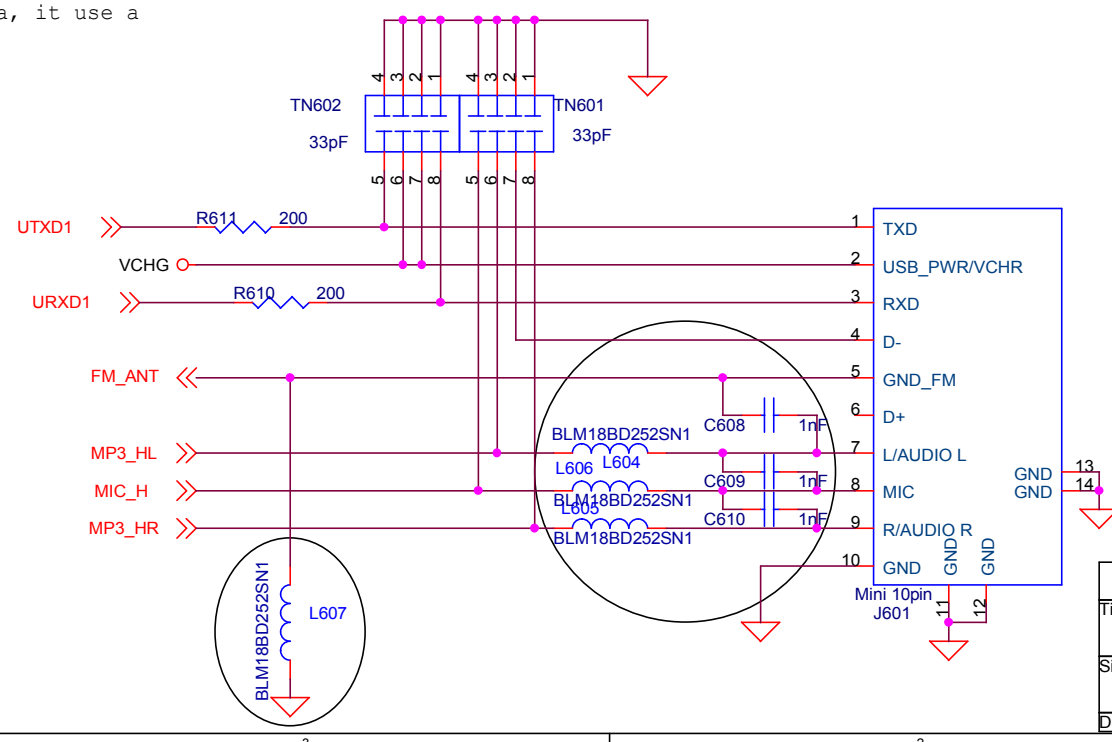

Title	<Title> <b>6 FM &amp; 10-pin I/O</b>		Rev
Size	Document Number	<Doc>	
A3	<Doc>	<RevCode>	
Date:	Sunday, August 26, 2007	Sheet	6 of 8

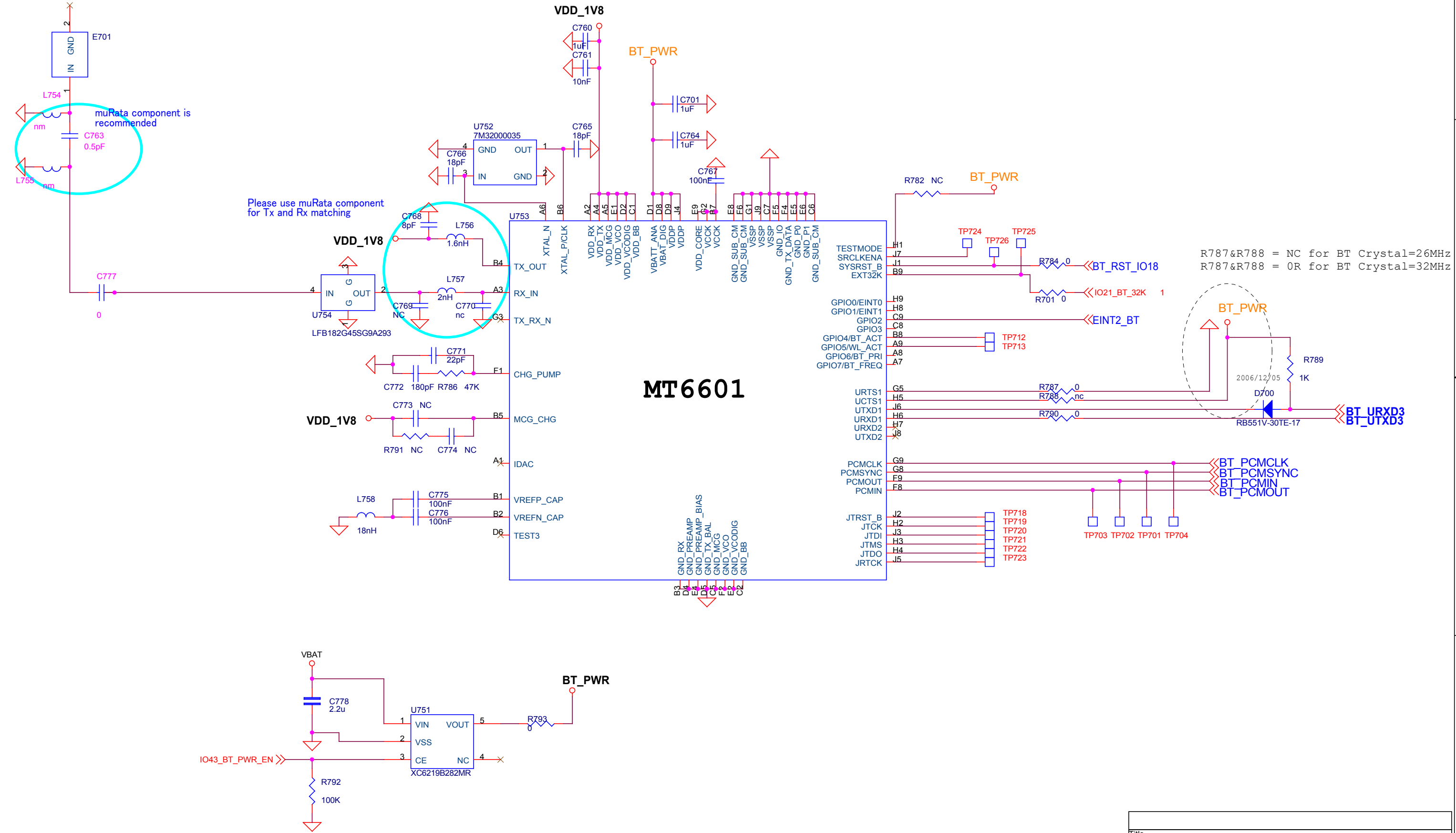

Please use muRata component for Tx and Rx matching

muRata component is recommended

R787&R788 = NC for BT Crystal=26MHz  
 R787&R788 = 0R for BT Crystal=32MHz

**MT6601**

Title		<b>7 BT-MT6601</b>	
Size	Document Number	Rev	
A3	<b>BT-MT6601</b>		
Date:	Sunday, August 26, 2007	Sheet	7 of 8



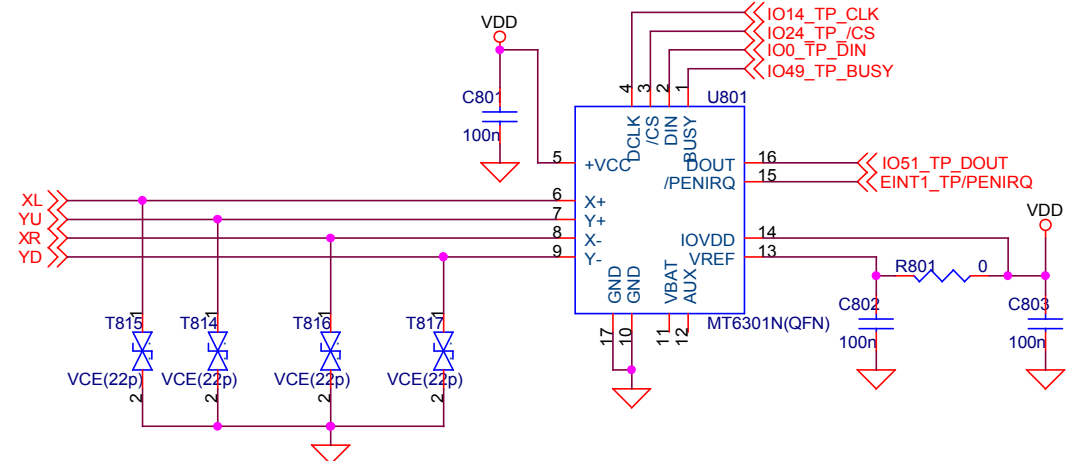
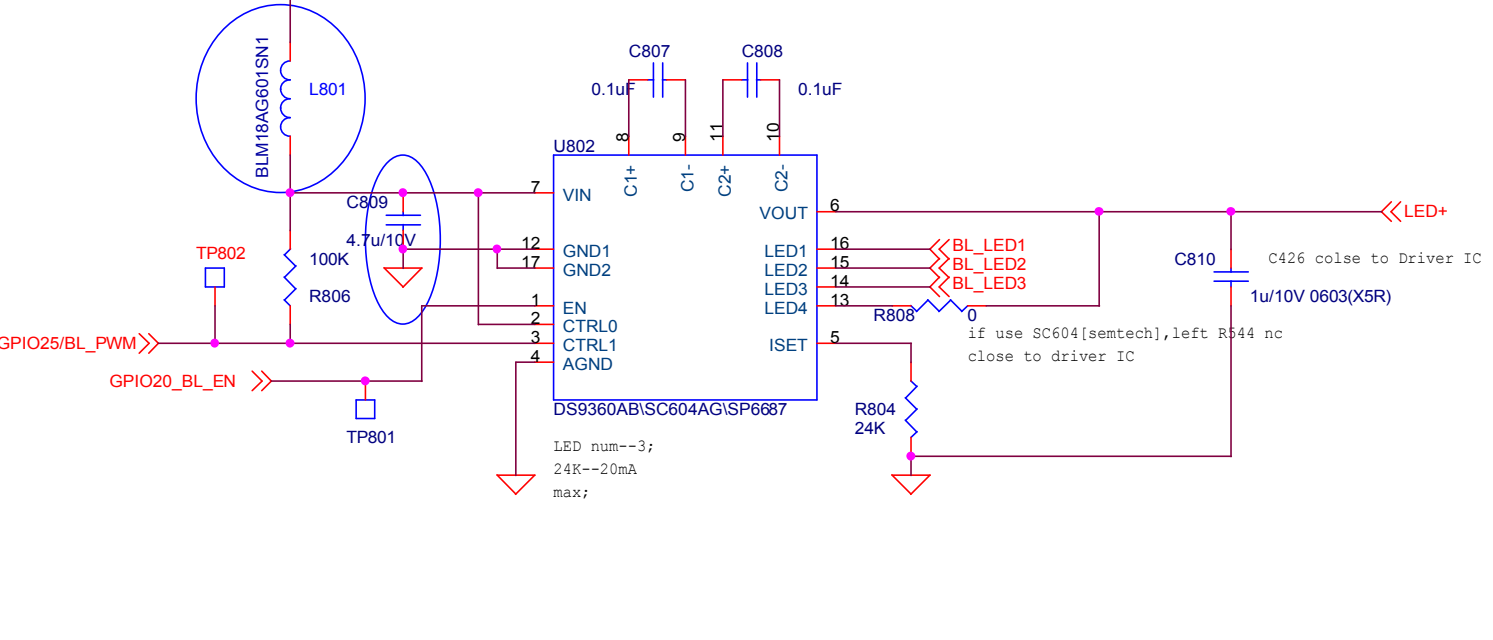
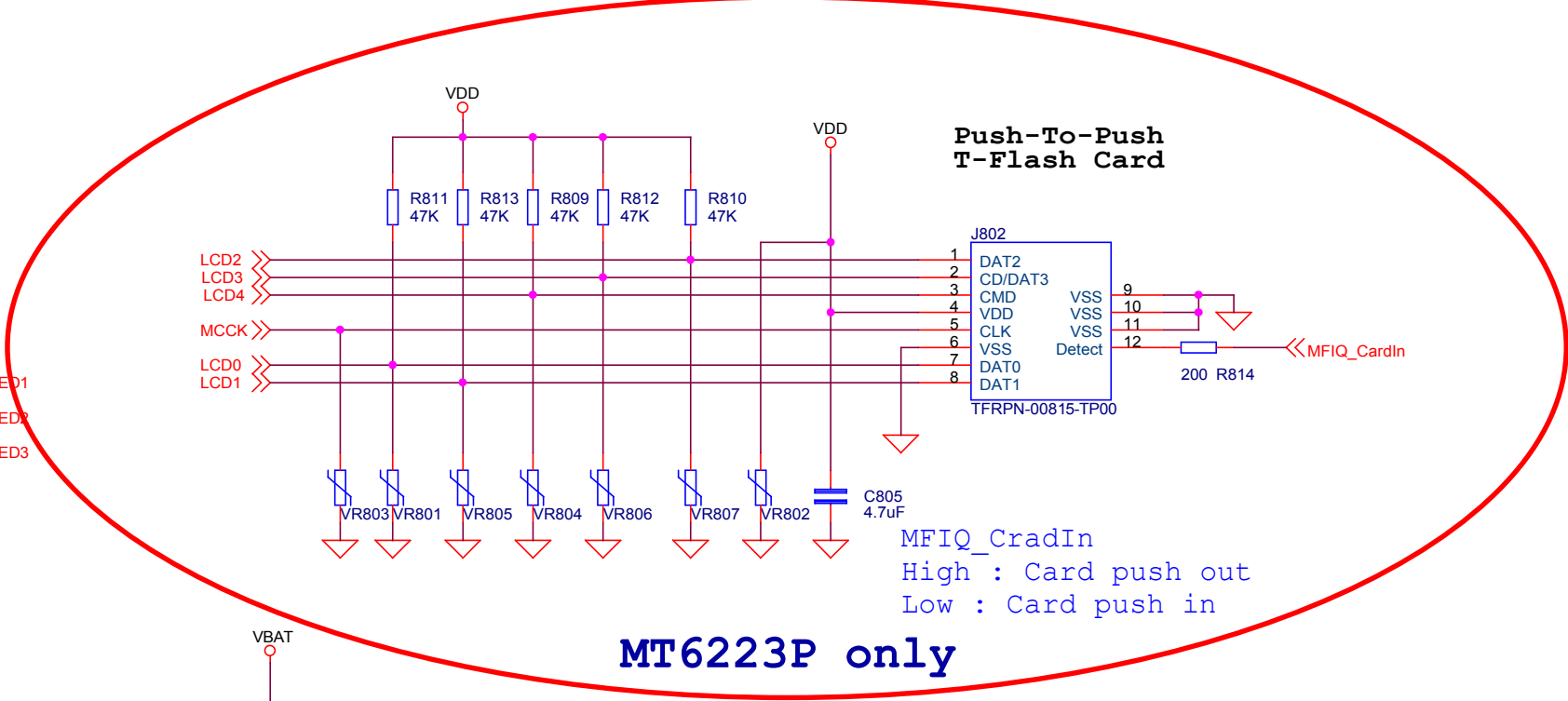
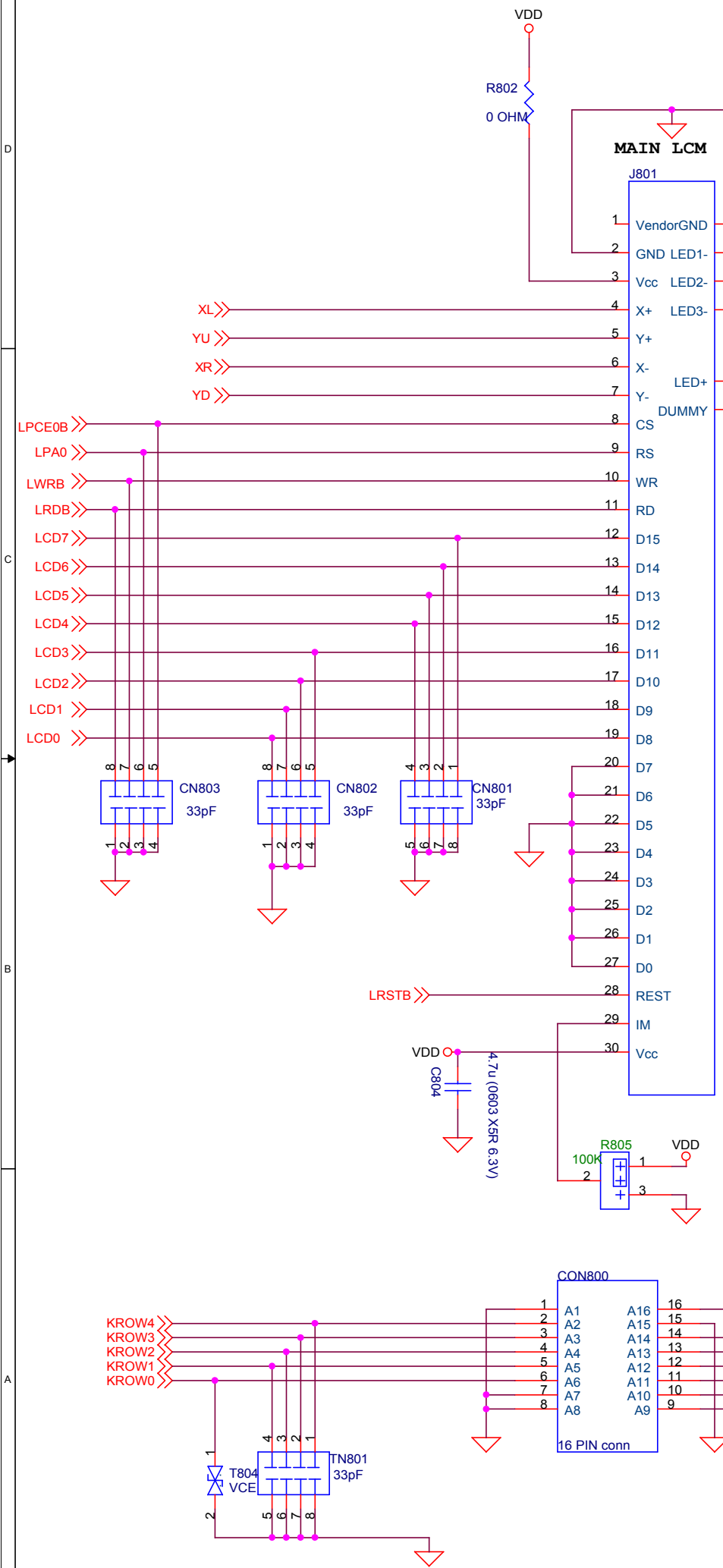

1-2 : 100K  
 2-3 : 0 ohm

Title <Title> <b>8 LCM &amp; Touch Panel</b>		
Size A3	Document Number <Doc>	Rev <RevCode>
Date: Sunday, August 26, 2007	Sheet 8 of 8	